

Научная новизна. Предлагается инновационный способ резания угля в очистном забое, который обеспечивает уменьшение удельной энергоёмкости резания пласта до 10 раз по сравнению с существующими очистными комбайнами. Общая мощность электродвигателей выемочного манипулятора составляет около 50 кВт.

Практическая значимость. Внедрение технологии добычи угля с минимальным присутствием рабочих за счет применения адаптивно-программного управления; снижение удельной энергоёмкости разрушения полезного ископаемого выемочной машиной и металлоёмкости очистного комплекса и выемочного манипулятора в 2–3 раза по сравнению с существующими узкозахватными комбайнами. Внедрение робототехнологических комплексов позволит повысить эффективность взаимодействия

человека-оператора и диагностической системы очистного робототехнологического комплекса и свести к минимуму опасность для работающих при подземной добыче угля. Появляется возможность расконсервации и разработки техногенных запасов месторождений полезных ископаемых в сложных горно-геологических условиях.

Ключевые слова: *очистной роботизированный комплекс с адаптивно-программным управлением (ОРКАПУ), механизированная крепь, выемочный манипулятор фронтальный (ВМФ), человек-оператор, микропроцессорная система управления*

Рекомендовано до публікації докт. техн. наук Ф. К. Нізаметдіновим. Дата надходження рукопису 20.05.15.

УДК 622.830

**М. В. Nurpeisova, Dr. Sc. (Tech.), Prof.,
О. А. Sarybaiev, Cand. Sc. (Tech.), Assoc. Prof.,
О. С. Kurmanbaiev, PhD**

Kazakh National Technical University named after K. I. Satpayev, Republic of Kazakhstan, Almaty, e-mail: marzhan-urpeisova@rambler.ru, sarybaev_o@mail.ru, olzhas_ak@list.ru

STUDY OF REGULARITY OF GEOMECHANICAL PROCESSES DEVELOPMENT WHILE DEVELOPING DEPOSITS BY THE COMBINED WAY

**М. Б. Нурпеісова, д-р техн. наук, проф.,
О. А. Сарібаєв, канд. техн. наук, доц.,
О. С. Курманбаєв, PhD**

Казахський національний технічний університет імені К. І. Сатпаєва, м. Алмати, Республіка Казахстан, e-mail: marzhan-nurpeisova@rambler.ru; sarybaev_o@mail.ru; olzhas_ak@list.ru

ДОСЛІДЖЕННЯ ЗАКОНОМІРНОСТЕЙ РОЗВИТКУ ГЕОМЕХАНІЧНИХ ПРОЦЕСІВ ПРИ КОМБІНОВАНОМУ СПОСОБІ РОЗРОБКИ РОДОВИЩ

Purpose. The introduction of modern geodetic array condition monitoring methods in order to establish laws governing the development of geomechanical processes in the combined method of developing Maykain gold deposit, ensuring high accuracy and performance of surveying.

Methodology. Analysis and synthesis of theoretical research in the process of displacement of different geological conditions of deposits, systematization of international experience in usage of combined development of gold deposits, experimental studies in the laboratory and mine conditions, analytical calculations, processing observation results by methods of mathematical statistics and computer modeling.

Findings. For safe and efficient extraction of gold, effects of natural and geotechnical factors on the development of deformation processes were studied, this allowed evaluating the possibility of regulating their influence on rock mass and engineering structures.

Geomechanical monitoring of the condition of the rock mass was conducted using modern surveying instruments, which provided high accuracy and performance of surveying.

The determined conditions of cracking in the rear sight between the open and underground workings allow obtaining information on changes of geomechanical condition of overlying layers of rock mass.

A scheme of rock mass movement during the application of the combined method of mining of Maykain deposit was established which allows choosing different ways of managing geomechanical processes.

Originality. Consists in developing a method of monitoring an array status on the basis of modern geodetic instruments, with a high information content and accuracy of the determination in the process of shifting patterns.

Practical value consists in the introduction high-precision geodetic methods into the production, namely, into system of geomechanical monitoring while combining open pit and underground works.

Keywords: *geomechanical processes, state of rocks, monitoring, modern surveying methods of monitoring, electronic tacheometers, levels, laser scanners, three-dimensional modeling*

Introduction. Currently gold mining industry of Kazakhstan is experiencing a number of difficulties associated with the fact that a significant portion of reserves, which lies in the most favorable geological and economic conditions, has been largely recovered from the earth depths of the republic while the remainder (about 45 %) is located in the deep horizons of the deposits of Maykain, Akbakai, Vasilkovsky and others. The fields newly introduced in operation cannot fully compensate for declining gold output at these enterprises, as they are characterized by significantly worse quality factors of reserves. As a result, to ensure a stable and effective work of the gold mining industry the transition from open pit to underground is required.

To meet the demands of the modern mining industry on ensuring industrial safety, the reliability of the information on the state of the rock massif in seismically active areas becomes an urgent issue. The analysis of research on major geomechanical problems served as preparation of new methods of conducting geo-monitoring, modeling VAT rock mass, waste mining and metallurgical complexes waste (MCW), aimed to reduce the risk of human-made disasters and to enhance the economic efficiency of mining in general.

Nowadays, predicting geomechanical processes is still a problem in all countries with developed mining industry, which once again was confirmed by the materials of the permanent 6th International Symposium on mining impacts and mine seismicity, held in 2005 in Australia [1]. Universally much attention has been drawn to geomechanical processes control, as evidenced by the increasing number of publications on this subject [2–5].

Moreover, the geodetic practice lacks a single method for conducting an array condition monitoring using modern surveying instruments. Therefore, the introduction of geodetic methods for geomonitoring to assess and predict the state of the massif is an urgent task as the basis of improving the safety of mining operations and the efficiency of extraction of minerals.

Analysis of the recent research and publications. Currently, it has been established that the main factors that determine the nature and magnitude of deformation of the earth's surface and rocks are mechanical properties and structural characteristics of the massif, its stress state, the depth of works, system design, size and angles of incidence of the ore bodies. A significant contribution to the study of the degree of influence of various factors on the development of geomechanical processes on ore deposits has been made by scientists S. G. Avershin, A. G. Akimov, I. M. Bakhurin, V. I. Borsch-Komponiets, J. S. Erzhanov, M. A. Iofis, I. A. Petukhov and others.

Scientific research and practical developments in the field of a displacement process in a combined method of field development is based on the research of K. N. Trubetskoy, A. A. Borisov, M. D. Kazikaev, Y. Kashnikov, M. V. Kurleni, M. A. Iofis, S. V. Kuznetsov, M. B. Nurpeisova, V. D. Slesarev, G. I. Black et al.

However, despite the results of the individual studies, the establishment of laws in general manifestations

of geomechanical processes in these conditions are carried out by conventional methods. The rapid development of technology in the mining industry leads to the growth of mining operations, which, in turn, leads to the need for improved production technologies of service of mining operations, improved safety of shooting. Over the last decade technical progress has had a significant impact on surveying maintenance tasks of quarry.

Professionals of the mining industry understand clearly that issues such as pressure and displacement of rock, pit wall stability, are unthinkable without geomechanical monitoring of massif status using modern geodetic techniques.

This situation is typical for the Maykain mine where authors conducted research on processes of movement of the earth's surface and rock masses under the influence of undermined career failures and a great depth. Therefore, practical application of electronic and laser devices can be considered the most significant technological innovation at the beginning of the 21st century in surveying, geodesy and a number of related industries.

Objectives of the article. The aim of this study is introduction of modern geodetic methods of massif condition monitoring in order to establish laws governing the development of geomechanical processes in the combined method of developing Maykain gold deposit, ensuring high accuracy and performance of surveying.

Research methodology includes research in the laboratory and mine conditions, analytical calculations, analysis of observations by methods of mathematical statistics and computer modeling.

Combined mining leads to the formation of complex biomechanical systems, characterized by a repeated exposure of the same areas of the rock mass to stress during simultaneous or sequential open pit and underground operations. The assessment of geomechanical state under these conditions is complicated by the fact that the state of the massif depends on a number of influencing factors, it is constantly changing in space and in time.

While applying the combined method of development and complex geomechanical situation, issues of the threat of flooding underground workings and, in particular, the threat of a dynamic break of water into underground workings, leading to serious negative consequences, become of crucial importance. An example of this is water breakthrough that occurred in 2009 at Maykain mine of "Altynalmas" JSC in Kazakhstan. This issue is relevant not only for Kazakhstan. Thus, in 2006, the mine of Hunbey province in China was flooded, as well as Severnaya mine of "Severokuzbaugol" in 2010, Osennikovskaya mine in Russia in March 2013, Krepenskaya mine in Ukraine in February 2013, which resulted in loss of lives. All this is a direct consequence of the change of the geodynamic and hydrogeological regime of the geological environment under the influence of large-scale mining operations that is clearly supported by the results of research on the example of Maykain mine [6].

Presentation of the main research and results.

Considered natural-technical system (NTS) “Maykain” includes an underground mine and two open pits, tailings from the processing plant and related infrastructure being part of the geological environment of the Unified folded system [6–8].

A characteristic feature of Maykain deposit is its development by open pit method first, followed by the transition to underground methods. The possibility of displacement process of rocks in the deposit is caused by the fact that the applied system of mining, development is conducted by separate units with ore shrinkage, production of pillars and ceiling. With this combined system, the development of rock mass from the hanging side around the full length and the entire depth loses support and is bound to deteriorate, causing the process of rock shifting. The problem of determining the boundaries of the impact of underground mining on the earth’s surface in this case is considered as a definition of the side sliding surface at the bottom of the recess of quarry.

Therefore, to solve a number of problems of mining, methods of calculation should be adjusted to the specific conditions, and, thus, it is necessary to take into account the impact of natural and mining factors, as well as the variability of the strength properties of rocks in space and time, and others.

Despite the large number of research works [2–5], the issue of risk management and predicting of technogenic catastrophes has not been solved yet due to the complexity and great diversity of geological features of the deposit.

State analysis of techniques of geodetic observations on the territory of the NTS and Surveying interpretation of the data in relation to the geomechanical and hydrogeological effects is primarily associated with the lack of effective methods of determining the values of subsidence of the Earth’s surface (SES), which leads to the need of improving methods of surveying and geodetic observations over deformations of rocks using modern electronic devices to improve the reliability, efficiency in the determination of SES parameters for the safe development of mineral resources and the adoption of conservation measures of developed facilities.

In general, geodetic observations using new generation devices make it possible to identify the strain of the massif, which is essential for assessment of the geodynamic situation in the area of mining. But they do not provide a complete picture of deformation processes in time. This can be realized only with the use of a complex technique of studying the natural-technical system, based on conducting geomechanical monitoring. Fig. 1 shows the structure of a technique of studying and predicting geomechanical condition in NTS.

Based on the analysis of geology and tectonics of the area (block 1 of the technique), experimental estimates of the stress state (block 2) and the instrumental record (block 3) in the massif “high power” zones are allocated, which determine the geodynamic monitoring zone boundary. Then monitoring of the danger zone is organized, which includes primarily control of the deformation and geophysical field parameters. In the future, all information on the patterns of displace-

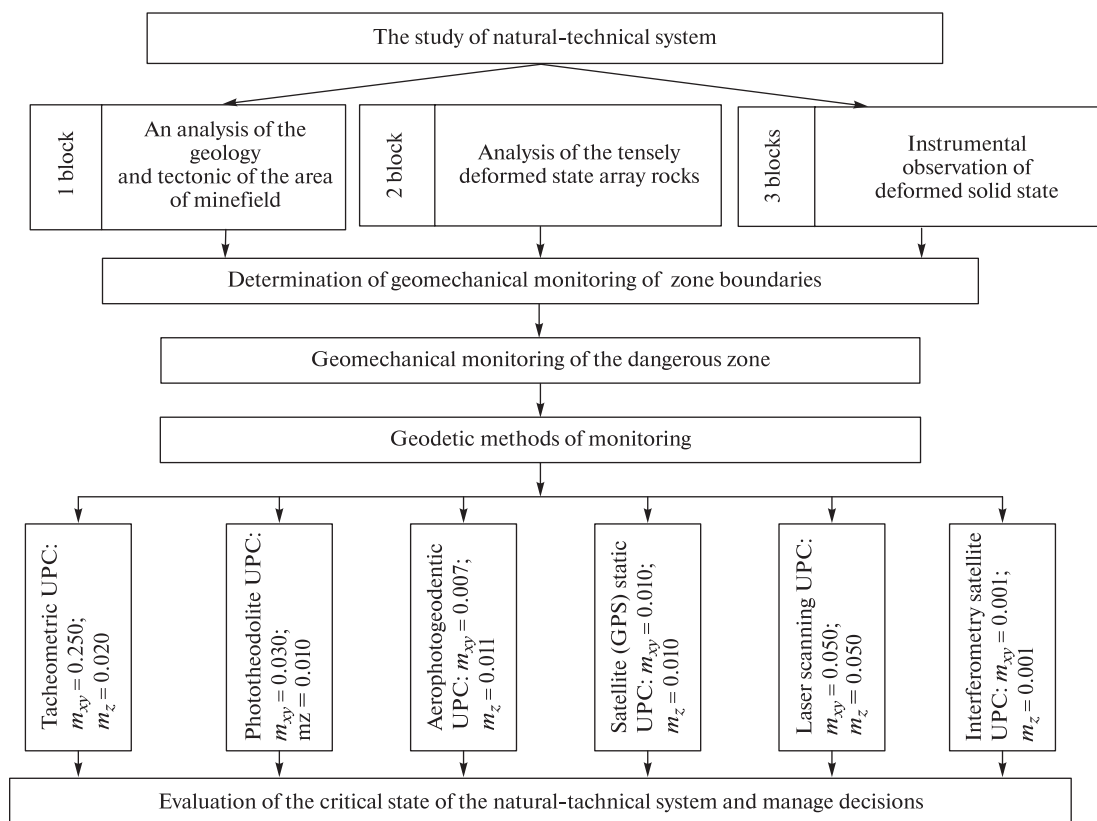

Fig. 1. Diagram of a technique of studying the prediction of dangerous phenomena in the NTS

ment process of the system and the parameters of its critical state are transferred to an expert system, where on the ground of database integration and knowledge assessment of the NTS state is conducted and the relevant decisions on conservation of resources and the earth's surface are made.

Regarding the scale of the impact on the environment and especially on the stress-strain state of the rocks, Maykain deposit development belongs to the category of major technological influences that can cause serious accidents, catastrophic phenomena, such as large landslides, local and large-scale collapse of the quarries, the pressure and bursting on the bottom of the mine horizons, caused by an imbalance in the bowels of the earth [6].

The geological structure of the Maykain ore deposit consists of volcanogenic-sedimentary rocks of the lower Middle Cambrian age (Fig. 2). Within the central syncline, faults are common.

Maykain deposit belongs to steep dipping vein type of gold ore body, latitudinal, with capacity of 0.2–4.0 m. The length of the ore bodies along strike are within the range of 100–680 m. The host rocks are granodiorites with the fortress factor of $f = 14–16$, beresites ($f = 11–14$), quartzites ($f = 16–18$).

Faults presented by systems of steeply dipping fractures of east-west trending play the main role in the structure of the ore field playing.

The extent of the impact of open cast mines and their waste dumps, tailings, underground mining is as follows: their effect is superimposed on each other, creating a folded pattern formation of secondary stress field. One of the aspects of this phenomenon is iso-static vertical movements. Therefore, production scale existing in the area requires in-depth study and control of the processes, which are taking place, in order to avoid uncontrollable catastrophic manifestations of the geomechanical processes.

In such circumstances, an effective and safe testing of ore veins is only possible through organization of

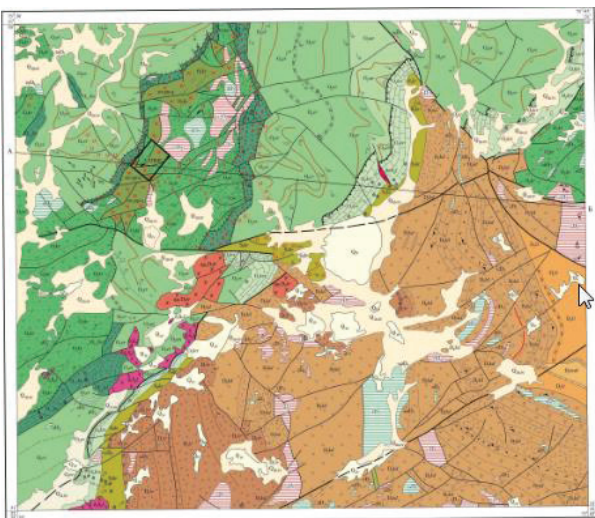

Fig. 2. Structural and geological map of the Maykain deposit

monitoring of geomechanical state of rock massif, comprising of the systematic observation of the space-time geomechanical processes occurring in the rock mass as a result of mining; in mathematical processing of observations; meaningful analysis and forecast of the state of rock masses, the development of solutions for the management of negative processes.

In 2000, based on biomechanical studies of mining and geological conditions of the deposit, project designs of observation stations were developed: surface and underground. The project addressed issues of a system based on geomechanical monitoring tools of surveying and geodetic observations using electronic tacheometers and GPS satellite positioning system receivers.

The widespread adoption of electronic tacheometers and GPS satellite devices into the practice of mine-surveying provides a unique opportunity to define the parameters of the rock mass displacement quickly and accurately, and to conduct regular, continuous monitoring of changes in these parameters over time.

In 2001, the station was founded, consisting of five core lines, covering all the ore-bearing veins. In the period of 2002–2010 16 observation series were carried out using a robotic electronic tacheometers TCA 1202 (Leica Geosystems, Switzerland). Application of electronic tacheometers will automate the process of measurement and eliminate the error of electronic surveying instruments at reflective prism (Fig. 3), and also significantly reduces the production of field work, while the development of a database in electronic format greatly simplifies the cameral processing of measurement results [7, 8].

Transmission precision of elevation by electronic tacheometers is determined by calculating an error exceeding the trigonometric leveling using the formula, mm

$$m_h^2 = L^2 \cos^2 \delta \frac{m_\delta^2}{\rho^2} + m_L^2 \sin^2 \delta + 2m_v^2,$$

where m_δ , m_L , m_v are mean square errors of vertical angle, distance and height of the instrument and the reflector.

For the electronic tacheometers Leica TC 1201 standard errors of data values are $m_\delta = 1 //$; $m_L = 2 \text{ mm} \pm 0.5L \text{ mm/km}$; $m_v = m_i = 1 \text{ mm}$.

Years of experience of surveying instrumental observations over deformations of rock mass at the mine allowed introducing the methodology of observations using GPS equipment (Fig. 4).

Method of laser scanning was used to study the state of the array at the board in the quarries. Laser



Fig. 3. Monitoring by electronic tacheometers



Fig. 4. Observations using GNSS

scanning allows creating a digital model of the entire surrounding area, presenting it as a set of points with spatial coordinates. For observations over deformations, a scanner of Leica HDS3000 type was used, while the Leica HDS4400 mountain scanner, having a high performance and special software for the study of the elements of occurrence, was used to study the structure of the massif. To improve efficiency of observation, GPS-systems and 3D-scanner can be used simultaneously [9].

On the basis of complex geomechanical monitoring carried out at the Maykain field in the period of 2001–2010 the scheme of displacement of rocks was developed (Fig. 5). It highlighted two areas: unloading and high mountain pressure, and eight areas with different characteristics, inherent only to features of these zones.

The unloading area is divided into zones, characterized by varying degrees of disturbance of the massif caving, through local and cracks.

According to this scheme eight underworked thicker zones can be distinguished, which differ in terms of the degree of deformation and fracture. Features of zones and their quantitative parameters are used in the evaluation of the geomechanical and hydrogeological state of rocks in the development of mineral resources under water objects. Natural hydro geologic radical

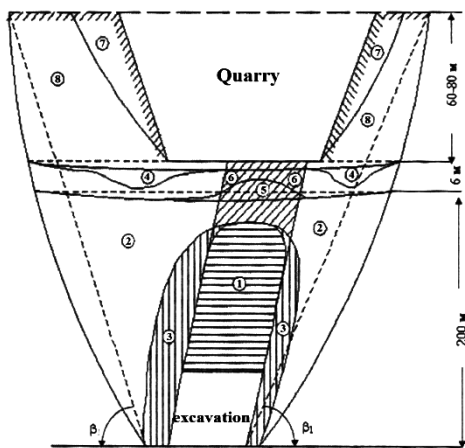

Fig. 5. Scheme of deformation of rocks during combined working of Maykain deposit

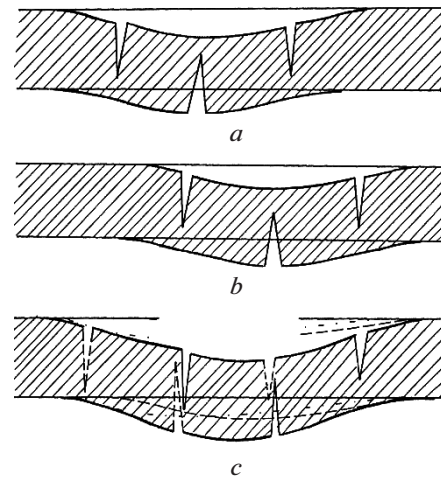

Fig. 6. Diagram of the formation of cracks in the under quarry layer during mining:

- a – first occurrence of cracks in the layer of curving;
- b – disclosure of the depth of cracks;
- c – destruction of the layer by alternating strains

change may also occur if water objects fall or collapse either into the zone or into the deflection zone forming a plurality of through water bearing cracks, or into deflection zone with the system of technogenic fractures.

The main attention was paid to the study of the bearing capacity of the bottom of the quarry (1 horizon) and sublevel pillar. Pillars are originally in an elastic state, but over time the salt pillars might get into the plastic state (or a yield condition), for instance, due to the development of rheological processes. Plastic condition is characterized by more than tenfold increase of pillar ductility while maintaining their state of stress.

Further increase of the span leads to corresponding increase in the tensile stresses and crack propagation.

The analysis of the mined massif state was conducted from two perspectives. First, the potential risk of development of vertical fracture system in a waterproof stratum (WPS) massif was evaluated; the fractures may be the channels of groundwater leakage in the mined space of ore. Secondly, the possibility of formation of weakened zones in the upper part of the section due to the the influence of mining operations was considered, which can pose a real danger to the ground facilities and engineering structures.

Conclusions. The developed method of complex evaluation of rocks allows considering the features of the geological structure of undermined strata and, thus, enhancing the quality of geomechanical maintenance of mining. In turn, the results of geomechanical predictions enable us to determine the most dangerous areas, where geophysical and geodetic-surveying observations should be conducted to localize zones of anthropogenic disturbance.

The results of practical realization and implementation of the research and theoretical developments in the mining operations are confirmed by perennial instrumental geodesic-surveying observations of the state of the massif.

References/Список літератури

1. Rockburst and seismicity in mines proceedings.- Australia: Australian Centre for Geomechanics, 2005.
2. Viktorov, S. D., Iofis, M. A. and Odintsev, V. N., 2005. Destruction of rocks and the risk of man-made disasters. *Mining Journal*, No. 4, pp. 30–35.
- Викторов С.Д. Разрушение горных пород и риск техногенных катастроф / С.Д. Викторов, М. А. Иофис, В. Н. Одинцев // Горный журнал. – 2005. – №4. – С. 30–35.
3. Owen, M. L., 2005. Calibrating a semi-quantitative seismic risk model using rockburst case studies from underground metalliferous mines. In: Australian Centre for Geomechanics, *Controlling seismic risk, Sixth International Symposium on Rockburst and Seismicity in Mines Proceedings*. Australia, 9–11 March 2005. Australian Centre for Geomechanics
4. Chernyi, A. D. and Terentiyev, V. I., 1998. *Complex open-underground mining of side and under quarry reserves of ore deposits*. Moscow: IPKONANSS-SOR.
5. Kaplunov, D. R. and Chaplygin, I. I., 2003. Principles of projecting combined technologies during mining of large deposits of solid minerals. *Mining journal*, No. 12, pp. 18–23.
6. Sashurin, A. D. and Panzhin, A. A., 2005. Diagnosis of geomechanical condition of rock massif geodetic methods. In: Problems of geotechnology and geology, pp. 170–178.
- Сашурин А.Д. Диагностика геомеханического состояния массива горных пород геодезическими методами / А.Д. Сашурин, А.А. Панжин // Проблемы геотехнологии и недроведения. – Екатеринбург: ИГД УрО РАН, 2005. – С.170–178.
7. Iofis, M. A., Miletenko, N. A. and Odintsev, V. N., 2011. Geomechanical approach to forecast dangerous hydrological processes in the development of solid minerals. *Mining Informational and Analytical Bulletin (scientific and technical journal) GIAB*, No. 7, pp. 103–108.
- Иофис М.А. Геомеханический подход к прогнозу опасных гидрогеологических процессов при разработке твердых полезных ископаемых / М.А. Иофис, Н.А. Милетенко, В.Н. Одинцев // ГИАБ. – 2011. – № 7. – С. 103–108.
8. Miletenko, N. A. and Nurpeisova, M. B., 2014. Hazardous Weather geomechanical processes at the combined method of field development. *Mine Surveying Bulletin*, No. 4, pp. 55–58.
- Милетенко Н.А. Прогноз опасных геомеханических процессов при комбинированном способе разработки месторождений / Н.А. Милетенко, М.Б. Нурпеисова // Маркшейдерский вестник. – 2014. – № 4. – С. 55–58.
9. Nurpeisova, M. B., Kyrgyzbaeva, G. M. and Sarybayev, O. A., 2015. Monitoring of the earth's surface displacements during the subsoil development, Balkema, pp. 161–169.

Мера. Впровадження сучасних геодезичних методів контролю стану масиву, для встановлення

закономірностей розвитку геомеханічних процесів при комбінованому способі розробки золоторудного родовища Майкаїн, що забезпечують високу точність і продуктивність знімальних робіт.

Методика. Аналіз і узагальнення теоретичних досліджень процесу зсування в різних геологічних умовах відпрацювання родовищ, систематизація світового досвіду використання комбінованої розробки золоторудних родовищ, експериментальні дослідження в лабораторних і шахтних умовах, аналітичні розрахунки, обробка результатів спостережень методами математичної статистики та комп'ютерного моделювання.

Результати. Для ефективного й безпечного видобутку золотих жил досліджена дія природних і гірничотехнічних чинників на розвиток деформаційних процесів, що дозволило оцінити можливість регулювання їх впливу на порідний масив і інженерні споруди. Проведено геомеханічний моніторинг стану масиву гірських порід за допомогою сучасних геодезичних приладів, що забезпечив високу точність і продуктивність знімальних робіт. Встановлені умови тріщиноутворення в ціліку між відкритими та підземними виробками, що дозволяють отримати інформацію про зміни геомеханічного стану вищерозміщених шарів масиву гірських порід. Встановлена схема зсування гірських порід при комбінованому способі розробки родовища Майкаїн, що дозволяє вибирати різні способи управління геомеханічними процесами.

Наукова новизна. Полягає в розробці методики ведення моніторингу стану масиву на основі використання сучасних геодезичних приладів з високою інформативністю й точністю, що дозволяє встановити закономірності процесу зсування.

Практична значимість. Полягає у впровадженні у виробництво високоточних геодезичних методів у систему геомеханічного моніторингу при поєднанні відкритих і підземних робіт.

Ключові слова: геомеханічні процеси, стан гірських порід, моніторинг, сучасні геодезичні методи моніторингу, електронні тахеометри, нівеліри, лазерні сканери, тривимірне моделювання

Цель. Внедрение современных геодезических методов контроля состояния массива, для установления закономерностей развития геомеханических процессов при комбинированном способе разработки золоторудного месторождения Майкаин, обеспечивающих высокую точность и производительность съемочных работ.

Методика. Анализ и обобщение теоретических исследований процесса сдвижения в различных геологических условиях отработки месторождений, систематизация мирового опыта применения комбинированной разработки золоторудных месторождений, экспериментальные исследования в лабораторных и шахтных условиях, аналитические расчеты, обработка результатов наблюдений методами математической статистики и компьютерного моделирования.

Результаты. Для эффективной и безопасной добычи золотых жил исследовано воздействие природных и горнотехнических факторов на развитие деформационных процессов, что позволило оценить возможность регулирования их влияния на породный массив и инженерные сооружения. Проведен геомеханический мониторинг состояния массива горных пород при помощи современных геодезических приборов, который обеспечил высокую точность и производительность съемочных работ. Установлены условия трещинообразования в целике между открытыми и подземными выработками, позволяющие получить информацию об изменении геомеханического состояния вышележащих слоев массива горных пород. Установлена схема сдвижения горных пород при комбинированном способе разработки месторождения Майкаин, позволяющая выбирать различные способы управления геомеханическими процессами.

Научная новизна. Заключается в разработке методики ведения мониторинга состояния массива на основе использования современных геодезических приборов с высокой информативностью и точностью, позволяющей установить закономерности процесса сдвижения.

Практическая значимость. Состоит во внедрении в производство высокоточных геодезических методов в систему геомеханического мониторинга при совмещении открытых и подземных работ.

Ключевые слова: *геомеханические процессы, состояние горных пород, мониторинг, современные геодезические методы мониторинга, электронные тахеометры, нивелиры, лазерные сканеры, трехмерное моделирование*

Рекомендовано до публікації докт. техн. наук С. В. Турсбековим. Дата надходження рукопису 03.06.15.