

**Lyashenko V.,
Topolnij F.,
Dyatchin V.**

DEVELOPMENT OF TECHNOLOGIES AND TECHNICAL MEANS FOR STORAGE OF WASTE PROCESSING OF ORE RAW MATERIALS IN THE TAILINGS DAMS

Об'єктом дослідження є технологія і технічні засоби для складування відходів переробки рудної сировини в підземний вироблений простір і хвостосховища з додавкою затверджувача. Одним з найбільш проблемних місць є технологія складування відходів переробки рудної сировини, згідно з якою хвосты гідрометалургійного заводу (ГМЗ) направляються по пульпопроводу в хвостосховище у вигляді пульпи з співвідношенням по масі «тверде – рідке»: 1:2. Рідка фаза пульпи після відстоювання і освітлення в хвостосховищі повертається в технологічний цикл на ГМЗ. Дана технологія складування має ряд недоліків: високі одноразові капітальні витрати на будівництво хвостосховища на повну проектну потужність; велика ймовірність міграції шкідливих хімічних речовин в підземні води при пошкодженні захисних екранів основи або бортів хвостосховища.

В ході дослідження використовувалися дані літературних джерел і патентної документації в області обґрунтування параметрів сховищ, лабораторні та виробничі експерименти, фізичне моделювання і підбір складів твердіючих сумішей. Виконано аналітичні дослідження, порівняльний аналіз теоретичних і практичних результатів за стандартними і новими методиками за участю авторів.

Отримано і сформульовано механізм впливу міграційних пилових і водних потоків з масиву сховищ хвостів збагачення і металургійного переділу металовмісних руд. Показано, що міграція пилу припиняється при досягненні міцності закріпленого масиву на стиск $(1,0-1,5) \cdot 10^5$ МПа і швидкості повітряного потоку 15 м/с.

Встановлено можливість використання твердіючих сумішей із застосуванням в якості в'язучого відходів суміжного виробництва. Запропоновано оптимальний склад інгредієнтів на 1 м³ суміші:

- хвосты ГМЗ – 1350–1500 кг;
- в'язуче (цемент) – 50–70 кг;
- вода замішування – 350 л.

Запропонована технологія складування відходів переробки рудної сировини в підземний вироблений простір і хвостосховища з додавкою затверджувача дозволяє при виробничій потужності підприємства 1500 тис. т/рік 50–55 % хвостів використовувати для закладки виробленого простору (830 тис. т/рік). А іншу частину, з'єднану з в'язучим матеріалом, складувати в сховище (670 тис. т/рік). Завдяки цьому забезпечується можливість заповнення пов'язаними хвостами всієї існуючої площі дзеркала хвостосховища на висоту 10 м.

Ключові слова: відходи переробки рудної сировини, гідрометалургійне виробництво, хвостосховища, технології укладання, екологічна безпека.

Received date: 04.06.2019

Accepted date: 16.07.2019

Published date: 31.10.2019

Copyright © 2019, Lyashenko V., Topolnij F., Dyatchin V.

This is an open access article under the CC BY license

(<http://creativecommons.org/licenses/by/4.0>)

1. Introduction

Environmental technologies and technical equipment in developed mining countries are being improved taking into account environmental, economic, technological and social factors [1, 2]. One of the ways to reduce the anthropogenic load in the zone of influence of mining enterprises is improvement of the technologies for tailings storage after hydrocyclone and hardener additives [3, 4].

Therefore, it is urgent to develop technologies and technical means for storing waste from the processing of ore raw materials into underground space and tailings dams with the addition of hardener.

2. The object of research and its technological audit

The object of research is technologies and technical means for storing waste materials from ore processing into underground mined space and tailings dams with the addition of hardener.

A tailings dam is a complex of facilities designed for storing tailings of ore processing – the finely ground mineral mass formed during ore dressing at mining enterprises. Tails enter the tailing dams in the form of pulp with a ratio of the amount of solid mineral particles to water reaching 1:15–1:30. In practice, this ratio ranges from 1:0.3 to 1:70. Solids precipitates and clarified water is diverted

for reuse or discharged into a body of water. The structure of the tailings dams includes a primary dam and dams of subsequent tiers, antifiltration devices, drains, spillway structures, hydrotransport and dust suppression systems.

Tails of hydrometallurgical production is the solid particles formed as a result of hydrometallurgical processing of ore, ranging in size from fractions of a millimeter to a centimeter and containing unrecovered ingredients.

Ecological safety is a set of conditions, processes and actions that ensure the ecological balance in the environment and do not cause vital damage to the environment and humans.

One of the most problematic places is the technology for storage of ore processing waste, according to which the tailings of the hydrometallurgical plant (HMP) are sent through a sludge pipeline to the tailings dam in the form of pulp with a solid to liquid weight ratio: 1:2. The liquid phase of the pulp after settling and clarification in the tailings dam is returned to the technological cycle at the HMP. This storage technology has several disadvantages:

- high one-time capital costs for the construction of a tailing dam at full design capacity;
- high probability of the migration of harmful chemicals into groundwater in case of damage to the protective shields of the base or sides of the tailings dam.

3. The aim and objectives of research

The aim of research is development of technologies and technical means for storing waste from the processing of ore raw materials into underground space and tailings dam with the addition of hardener. To achieve this aim it is necessary to perform the following objectives:

1. To systematize the technologies and technical means for storing waste from the processing of ore raw materials into the underground mined space and tailings dam with the addition of hardener.
2. To establish the possibility of using hardening mixtures with the use of adjacent production as binders and to propose the optimal composition of their ingredients per 1 m³ of the mixture.
3. To recommend an analytical model for determining the efficiency of mining by comparing options for the development of deposits (including man-made), taking into account costs at all stages.
4. To propose technologies and technical means for using them in the feasibility study for the construction of an enterprise on the basis of the Novokostiantynivka ore deposit (State Enterprise «East Ore Mining and Processing Plant» – SE «EastOMP», Zhovti Vody, Ukraine).

4. Research of existing solutions of the problem

In world practice, the main way to protect the environment and humans from the harmful effects of industrial waste containing radionuclides is storing them in isolated conditions (underground mined spaces and special storage facilities on the surface) [5, 6]. The most promising way to create tailings dams is a combined one, in which the processing waste is placed in a specially equipped natural depression with a dyke [7, 8]. In this case, one part is constructed from inert soils, and the other from recycled ore material mixed with a binder component [9, 10].

The authors performed an analysis of literature and patent documentation in the field of tailings storage after hydrocyclone and hardener additives in tailings dams [11, 12]. As well as laboratory and production experiments, physical modeling and selection of compositions of hardening mixtures according to standard and new methods [13, 14].

Based on the analysis, it can be concluded that reducing the environmental hazard by storing waste from ore processing into underground mined space and tailings dams with the addition of hardener solves important scientific, practical and social problems [15, 16]. This is achieved by curing hazardous ingredients, determining the formulations of hardening mixtures, assessing their strength to fill underground mined spaces and surface maps of the storage and solidification [17, 18].

5. Methods of research

During the study, the following stages of the study were carried out:

- analysis of world experience in handling waste from hydrometallurgical processing of radioactive ores;
- collection and analysis of materials on technologies for storage and immobilization of mining waste in surface storage;
- determination of effective technology for the immobilization and storage of HMP tailings;
- determination of requirements for physico-mechanical, radiochemical indicators of stored waste and for tailings dam;
- establishment of physical and mechanical properties of a mixture of HMP tailings with a binder (mobility, adhesion, strength, filtration, leaching) and radiological indicators (emanation coefficient, radon flux density);
- development of technologies and recipes for hardening mixtures for laying them in the maps of the surface storage and in the underground mined spaces of the mine;
- determination of the main technical and economic indicators of the technology of preparation and laying of the hardening mixture;
- assessment of the impact of the technology of preparation and placement of the hardening mixture in the tailings dams on personnel, the environment and the population living in the zone of its influence.

6. Research results

6.1. Characterization of tailings dams of hydrometallurgical production. They use alternate multi-storey tailings, from dams along the perimeter of the entire tailings dam pit. Pulp production can be either underwater or surface. With this storage, most of the washed tailings are under water. However, both in the process of reclamation and after storage at the tailings dams, dehydrated areas (alluvial beach) are formed, which are in this state for several months a year. Alluvium beach (slightly inclined plane towards the settling pond) is formed along the entire perimeter of the tailings dam. The width of this plane depends on the method used for storing the tailings and ranges from 100 to 500 m. There is an experience in the map washing of the tailings, in which the tailing dam is divided into compartments (maps), separated from

the main by dividing dams. Pulp is discharged in one of the map sections and is washed in layers, after which the outlet pipes in this section are closed and the next section is included in the work. When the height of the layer of design marks is reached, the wash-up stops, the map stops at the «sludge», the duration of which depends on the size, number of maps on the tailings dam and the intensity of the storage process and is 1.5–2 years.

So, from the beginning of the exploitation of the Zhovta Richka iron ore (1895) and uranium (1951) deposits (Ukraine) were formed (Fig. 1):

- 2 quarries «Gabaevskiy» and «Veseloivanovskiy»,
- 4 tailings dams – spent quarry of brown iron ore quarry (BIOQ), «Razberi» and «Ternovskaia» and a collapse funnel – as a result of underground mining of an iron ore deposit by systems with forced collapse of ore and surrounding rocks (SE «EastOMP», Zhovti Vody city, Ukraine);
- Shcherbakovska arroyo (SE «EastOMP, Petrovskiy District, Ukraine) (Fig. 2, a).

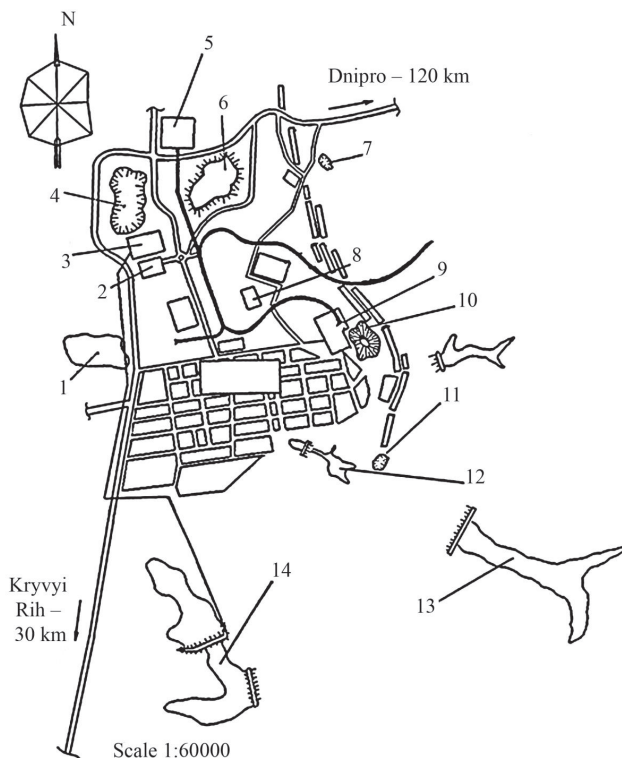

Fig. 1. Zhovti Vody industrial site:

- 1 – ash dam of waste from a thermal power plant (TPP); 2 – TPP;
- 3 – hydrometallurgical plant; 4 – tailings dam of brown iron ore quarry;
- 5 – sulfuric acid plant; 6 – reclaimed dam; 7 – «Veseloivanovskiy» quarry;
- 8, 9 – «Olkhovska» and «Nova» mines; 10 – collapse zone (failure);
- 11 – «Gabaevskiy» quarry; 12, 13, 14 – tailings «T», «P» and «III»

Thus, the existing tailings dams have dehydrated sites (surface alluvial beaches, map areas located on the «lag» external slopes of dams and dams) are an intensive source of dust formation. They are in this state for several months a year. In summer, the surface heats up to 80 °C and the dry layer reaches 30–50 cm. Dry tails are loose sand material, between the particles of which there are no stable bonds. The content of dust particles $C \leq 0.07$ mm is more than 65 %, and the particles of the fraction ≥ 0.01 mm – up to 25 %.



a



b

Fig. 2. General view of the tailings dams for the storage of waste hydrometallurgical ore processing: a – Shcherbakovska arroyo; b – mining engineering reclamation at the tailings dam of brown iron ore quarry

Ore mining in mines and quarries led to the formation of waste rock dams and off-balance ones, in terms of the content of useful components, ores and disturbance of fertile lands, which today are partially restored by mining restoration (Fig. 2, b).

6.2. Hydrometallurgical waste management. Hydrometallurgical waste management consists in their storage in tailings dams on the territory of the ore processing plant or at a distance from it.

Three types of tailings are distinguished: alluvial, bulk and combined. In alluvial tailings dams, the bulk of the enclosing dam is washed from processed ore material and in bulk – the dam is constructed from mineral materials.

One of the active sources of environmental pollution by ore dressing products is tailing dams. In the process of equipping tailings dams, dehydrated areas of large area are formed on their surfaces. In summer, the surface heats up to 60 °C and the dry layer reaches a thickness of 30–50 cm. Dry tails are loose sand material, between the particles of which (except for insignificant surface tension forces, molecular, chemical bonds and silicatization) there are no stable bonds, for example, dust. At a wind speed of 5 m/s or more, the surface of the tailings becomes an intensive source of dust, the concentration of which in the air above the storage and at a distance of several kilometers is tens

and hundreds times higher than the maximum permissible concentration (MPC).

The traditional way to control dust on dry beaches of tailings dams is based on fixing dusty surfaces by creating films or anti-erosion crusts. Humidification is the most widely used dust control method, which is widely used at the highest altitude tailing dap in the world of Mauro at the Los Pelambres copper and molybdenum mine in Chile since 2008 (Fig. 3) [19]. A wet beach also does not dust, but moisture sometimes evaporates and such a beach requires an additional supply of water, which is very expensive. In addition, the reclamation of such tailing dams will be difficult due to the low strength of their surfaces.

Fixers are applied to the surface of the tailings dams. In bulk-type tailing dams, light fractions (silt and clay) are concentrated in the upper layer of beaches. Up to 90 % of the particles of these fractions are in the upper (10–20 mm) layer. The filtration coefficient of the upper layer is on average 0.02–0.03 m/day. Due to the low filtration, the penetration of fixing solutions deep into the tails does not occur and an insoluble crust does not form. After drying, a thin film forms on the surface of the fixer, which is easily destroyed and washed off with water. Most of the fixing mortar escapes along cracks or collects in formed depressions. Anti-erosion film is a sliding plane with reduced strength characteristics – the angle of internal friction and adhesion, which contributes to the destruction of dams. Tails with various fillers and additives undergo natural leaching, which products violate the ecosystem of the environment [20, 21].



Fig. 3. The technology of moistening the dusty surfaces of the Mauro tailings dam at the Los Pelambres copper-molybdenum mine in Chile (photo) [19]

Fixers are applied to the surface of the tailings dams. In bulk-type tailing dams, light fractions (silt and clay) are concentrated in the upper layer of beaches. Up to 90 % of the particles of these fractions are in the upper (10–20 mm) layer. The filtration coefficient of the upper layer is on average 0.02–0.03 m/day. Due to the low filtration, the penetration of fixing solutions deep into the tails does not occur and an insoluble crust does not form. After drying, a thin film forms on the surface of the fixer, which is easily destroyed and washed off with water. Most of the fixing mortar escapes along cracks or collects in formed depressions. Anti-erosion film is a sliding plane with reduced strength characteristics – the angle of internal friction and adhesion, which contributes to the destruction of dams. Tails with various fillers and

additives undergo natural leaching, which products violate the ecosystem of the environment [20, 21].

6.3. Dust suppression technology with bitumen emulsion. For stationary use of the technology, the following equipment and facilities are required:

- emulsion generator: bitumen emulsion warehouse;
- equipment for loading and unloading emulsions;
- car, tractor or helicopter;
- attachments for emulsion spraying.

Dust suppression is carried out by applying a thin layer on the dusting surface of the bitumen emulsion. The bitumen emulsion consumption is 0.12 kg/m², i. e., to protect the required, for example, 1,000,000 m² dusty surface of the dam, about 120 tons of bitumen emulsion per year are necessary. To prepare 120 tons of emulsion, about 60 tons of bitumen, 60 tons of water and 3.6 tons of emulsifier are necessary.

The preparation of bitumen emulsion is carried out using a special emulsion generator. Dust protection is valid for one year. The layer of the applied emulsion on the alluvial beach does not create an anti-filter screen, i. e., it does not reduce the stability of the dam, does not pollute the filtration water with oil products or other harmful substances, i. e. it is environmentally friendly.

The above technological method of warehousing using maps is widely used, for example, at the OJSC Yuzhnyi Ore Mining and Processing Plant – OJSC Yuzhnyi OMP (Kryvyi Rih, Ukraine) [22, 23]. The disadvantage of this technology is its short validity period (one year), as well as the low strength of the surface layer of the storage, which will complicate the process of reclamation of this tailings dam. This technological method of waste storage using maps is also carried out without the inclusion of hardening additives in the waste. Therefore, the inclined layers described above can't be obtained and dehydration of the map surface will stretch in time, holding back the time of its restoration.

6.4. Technology, technical means and organization of storage of cured wastes of primary processing of ore raw materials.

An artificial array of tailings from the HMP is created in blocks equal to the monthly productivity of the tailings preparation complex. After laying, the block is left for a month to gain strength, and at this time, the adjacent block is laid. After a month, the block that has gained the required strength is reclaimed. The strength of the solid waste array, from the condition of safe operation of the equipment on its surface, should be 2–3 MPa for the upper bearing layer and 1.0–1.5 MPa for the remaining layers (Table 1).

On the recommendation of Engineering Dobersek GmbH (Germany), when preparing the tailings for curing, they are dehydrated to obtain pulp with a content of up to 80 % of the solid component and sent to the mixer for mixing with cement. The technological scheme for the preparation of enrichment fluids for immobilization contains a dewatering case, a thickener, a mixer, concrete pumps, batchers, and a concrete pipeline, tailings dam maps, branches and a conveyor [24, 25]. The tailings dehydration and backfill preparation complex includes: a dewatering case, three thickeners with a diameter of 50 m with a pump station, a mixing unit, a cement silo with a total capacity of 6 thousand tons.

Strength hardening laying based on the tailings
of the hydrometallurgical plant

Table 1

Parameters	Number of measurements (samples), pcs.	Average value
Density, t/m ³ :		
– slag	4	2.47
– tails	4	2.63
Humidity, %:		
– slag	5	8.00
– tails	5	19.00
Tail fineness modulus	4	0.08
The content of the fraction is 0.074 mm in the slag, %:		
– source	5	3.00
– milled	5	43.00
Bulk weight, t/m ³ :		
– hardening mixture	4	2.00
– ground slag pulp	4	1.48
– mixture mobility, cm	9	14.00
Water content, %:		
– in the mixture	4	31.00
– in the ground slag pulp	4	53.00
Consumption of materials, t/m ³ :		
– tails	4	1.17
– slug	4	0.38
The strength of the artificial massif, MPa:		
– 3 months	4	2.83
– 6 months	6	5.12

Before storing the tails, a 0.1 m thick sand layer is placed in the storage bowl to protect against tearing and deformation of the anti-filtration geomembrane. The design of the storage bowl includes:

- compacted loam with a thickness of 0.5 m, density 1.6 g/cm³ with a filtration coefficient of 0.1–0.2 m/day;
- geomembranes such as HDPE G/G (for the bottom) and HDPE T/G (for slopes 1.0/2.5);
- protective layer of sand with a thickness of 0.10 m and upland ditches for the entire period of filling the storage.

After completing the preparatory work, the antifiltration geomembrane is laid and welded according to the technology of AGRU (Austria). A geomembrane of the HDPE G/G type is laid at the bottom of the storage, and HDPE T/G type along the slopes. The laid geomembrane is covered with a layer of compacted loam with a thickness of 0.5 m to protect it from damage.

In the waste management practice of radioactive materials, curing is most often used, which reduces their natural leaching and stabilizes the physico-mechanical and radiological properties. Technologically developed mining countries are optimizing methods for curing waste from hydrometallurgical redistribution and the «dry» method of laying tailings in storage. A storage ditch is arranged around the storehouse to prevent rainwater from the adjacent territory from entering the storage bowl and a 2 m high fence. During the construction period, a settling pond is arranged in the area of the lower dam for collecting rainwater. Storage of ore waste in the cured state eliminates leaching and migration of chemicals into groundwater. The hardened surface of the laid tails allows to use the technique for reclamation of the storage. Technology reduces the area withdrawn from circulation and reduces capital costs.

Technologies for the storage of enrichment waste, which provide for the supply of sludge to the storehouse through the outlets of the sludge pipeline, in layers to different levels, ensure the spreading of the pulp stream in the opposite direction with the deposition of dust-clay particles [26].

Its disadvantage is that clarified sludge water accumulates on the entire surface of the storage, and rainfall and sewage are added to it. The accumulated moisture gradually evaporates or is removed after completion of its filling, which increases the time of hardening of sludge in the storage and reclamation of cells with sludge waste.

The authors propose changing the sequence of filling the cell with sludge, not over its entire area, but with inclined layers in the direction from one side of the cell to the other. This ensures the drainage of excess water along the inclined layers of the mixture to the drain hole and drain (drain) of water. It is produced from the cell through the drain holes without the use of special stationary or floating water intake mechanisms (Fig. 4).

In the pipeline 1 (Fig. 4), the pulp with the tailings of the enrichment of uranium ores is served in a mixture with a binder (cement). Through outlets 2, the pulp is placed in the cell 3 of the sludge store. The pipeline 1 with outlets 2 is placed on the longitudinal sides 4 and the filling of the cell 3 begins through outlets 2 located near the transverse side 5. And on the other transverse side 5 at its upper edge, one or more drain holes 6 are made.

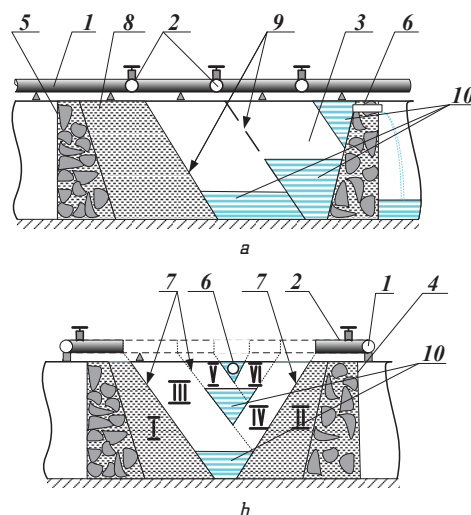

Fig. 4. Technology for the placement of waste from hydrometallurgical production in tailings dams: a, b – respectively, the layout of tailings in the longitudinal and transverse directions of the sludge store

The filling of the cell 3 of the tailings slimes mixed with cement is carried out in the following sequence. First, the outlet 2 is opened, for example, of the left longitudinal side 4 and the section I is filled, forming an inclined surface 7 directed towards the center of the cell 3. Then, the outlet 2 of the right longitudinal side 4 is opened and the section II is filled with an inclined surface 7 directed towards the section I. B the process of filling the cell 3 from the first extreme outlets 2, the excess liquid 10 of the pulp and rainfall on the formed inclined surfaces 7 will begin to drain to the center of the cell 3, contributing to the rapid curing of the pulp sections I and II.

By increasing outlets 2 on the left and right longitudinal sides 4, fill cell 3 from the same extreme outlets 2. This forms sections III, IV, V, VI with inclined surfaces 7 directed toward the center of cell 3, which also contribute to the drainage of excess fluid to the center cell 3. As a result, water removal from the cell is simplified and the curing process of the pulp in these areas is accelerated. When the sludge is initially filled only from the extreme outlets 2 to the upper level of the cell 3, a cured layer of mixture 8 is formed with an inclined surface 9, along which excess liquid 10 will drain to the bottom of the cell 3. After filling the sludge to the upper level, the extreme outlets 2 are closed. Filling of cell 3 begins from the following outlets in the same sequence as from the first. In this case, they form the same sections (I–VI) with inclined surfaces 7 and subsequent inclined layers 8.

When filling each next layer of the mixture 8, the water 10 accumulated in the lower part of the cell 3, squeezing out, is moved to the opposite transverse board 5. The same inclined layers 8 direct water 10 to the drain holes 6, through which water is drained into the next cell. After draining the water 10, the drain holes 6 are clogged and the filling of the cell 3 with the sludge mixture is completed. At this time, the dehydrated surface of the sludge, previously laid in cell 3 from the first extreme outlets 2, hardened and became suitable for conducting restoration work on it, without waiting for the entire cell to be filled with sludge. Consequently, the start and end dates of reclamation will be reduced. The proposed technology for the storage of waste in the storage ensures the removal of water from its surface due to the formation of inclined layers located both along the cell and across it. This ensures that the accumulated sludge accumulated at the bottom of the cell is filled with sludge to the side of the cell, where holes are installed to drain excess water without using water intake mechanisms [21, 22].

6.5. Environmental and economic efficiency of mining. The accumulation of waste from the extraction and processing of mineral raw materials is accompanied by a chemical effect on the environment of the toxic components of the waste, among which the most dangerous are heavy metals. Assessment of the use of tailings includes such elements as:

- forecasting the growth of production efficiency;
- transfer of off-balance sheet, according to the content of useful components, reserves to the category of balance sheet;
- coordination of activities for the regulation of technological processes;
- assessment, control and analysis of processing results.

The efficiency of mining can be determined by comparing options for the development of deposits (including man-made), taking into account costs at all stages. At the same time, the costs of protecting the population (including the costs of environmental protection, rehabilitation of contaminated and disturbed areas, human health, etc.) living in the zone of influence of mountain objects according to the proposed analytical model should be taken into account:

$$P = \sum_{i=1}^n [(V_{mo} - C_{mo} \pm (D + Z_n))] \frac{1}{1 + E^{t-1}} \cong \max,$$

where P – the profit from obtaining the final product from metal-containing ores, monetary units; V_{mo} – the

total recoverable value of the final product from metal-containing ores, monetary units; C_{mo} – the total cost of production and receipt of the final product, monetary units; D – total damage (economic consequences) caused to (–) the environment or prevented (+), taking into account the costs of protecting the population living in the zone of influence of mining enterprises (Z_n), monetary units; E – the coefficient of discounting costs and profits in time t of the application of the evaluated technology, the share of units.

6.6. Implementation results. Technologies with fixing leaching tails with secondary mineralization products for 40 years have been used in the development of the Bykogorske uranium deposit (North Caucasus, Republic of North Ossetia, Alania) using underground mine leaching with a 3 % sulfuric acid solution. As a result of the mudding processes, leaching tails acquired strength of 0.5–1.0 MPa [17, 18]. The authors systematize technologies for managing the status of tailings dams and proposed their classification (Table 2).

Table 2

Classification of tailings dams management methods

Technology	Methods	Advantages	Disadvantages
Top layer	claying	low costs, availability of materials	low strength
	cementation	high strength	high costs
	silicization	high strength	complexity
	carbonation	simplicity, reliability, carbonate utilization	difficult re-preservation
	bio fixing	simplicity and accessibility	in combination
	mudding without metal extraction	simplicity, reliability, waste disposal	metal and salt pollution
Total	without metal extraction	simplicity, reliability, disposal of electro-chemical products, environmental friendliness	not used the possibility of disposal with the receipt of goods
	with metal extraction	simplicity, payback, environmental friendliness	no

The classification given by the authors (Table 2) differs from the known ones in that the indicator of reagent removal into nature is adopted as the main criterion. As a result of the dust suppression performed according to the sanitary-epidemiological service, the dust content in the air above and around the tailings dam is below the maximum permissible concentrations.

The results of the study of hardening mixtures prepared on the basis of the tailings dam of the HMP for the construction of a model of the tailings dam show:

- the contact of the dam water and technical with the hardening mixture within the studied range of salt concentration and time does not destroy it and does not affect the strength;
- the filtration coefficient of the mixture is less than 1 cm per day, and the strength of the hardening mixture prepared with dam water is 25 % higher than with process water;

– drilled cores from the dam massif after one year of being in the open air did not lose strength and amount to 2.0–2.3 MPa. The hardening mixture after 100 «freezing – thawing» cycles received not significant peeling of the surface and the preservation of the form, in accordance with the requirements of SNIP – 56–76 it is considered frost resistant.

7. SWOT analysis of research results

Strengths. The proposed technology for the storage of waste materials from ore processing into underground mined space and tailings dam with the addition of hardener allows using the production capacity of the enterprise 1,500 thousand tons/year to use 50–55 % of tailings for laying the developed space (830 thousand tons/year). And the rest, combined with cementitious material, should be stored in storage (670 thousand tons/year).

Weaknesses. The main negative impact of the construction, operation of the storage and waste storage is the withdrawal of land from use. Therefore, it is necessary to provide funds for the following activities:

- reclamation of the storage area and the territory adjacent to it after the end of operation;
- landscaping of the reclaimed territory with grass and shrubs;
- continuous monitoring of environmental components in the storage area.

Opportunities. The proposed technology was used by the State Enterprise «Ukrainian Research and Design Institute of Industrial Technology» (Zhovti Vody, Ukraine) in the feasibility study for the construction of the enterprise on the basis of the Novokostiantynivka ore deposit (SE «EastOMP», Ukraine).

For the processing of industrial waste (tailings), which have a wide variety of mineral forms compared to conventional ores, it is necessary to create new technologies based on the latest achievements of science and technology. It is necessary to conduct intensive research aimed at solving the problem of disposal of accumulated waste from mining and metallurgical production (MMP). Implementation of effective methods for the extraction of metals from such wastes will improve the environmental situation in the areas of their storage and provide an increase in the mineral resource base of Ukrainian industry. The wide involvement in the production of technogenic reserves of ore dressing tailings, as well as the processing of off-balance dams, in terms of the content of useful components, of ores in modular plants, provide an additional source of meeting the industrial demand for metals. As well as reducing environmental pollution in developed mining countries of the world [27].

Threats. Separately, it should be noted the need to create protective forest belts along transport routes (road and rail). Territories where MPCs of pollution are exceeded must be transferred for sowing industrial crops; in water bodies, fishing, bathing, etc. should be prohibited. In order to prevent dust transfer of contaminated material outside the tailings dams, it is advisable to plant sanitary protective strips around them that will contain tall woody species that will restrain wind speed over tailings dams. In this case, dust will settle in these forest plantations and will not flow to other territories, including settlements. In addition, it is necessary to develop scientific

and methodological foundations, technologies and technical means to increase the fertility and efficiency of soil use in industrial zones of MMP, as well as to assess their impact on the environment and humans [20, 24].

8. Conclusions

1. The technology and technical means for storing waste from ore processing into underground mined space and tailings dam with the addition of hardener are systematized. And also their classification is carried out, which differs from the known ones in that the indicator of the transfer of reagents into the surrounding, geological and hydrogeological environment is adopted as the main criterion.

2. The possibility of using hardening mixtures with the use of adjacent production as binders is established and the optimal composition of their ingredients per 1 m³ of mixture is proposed:

- HMP tails – 1350–1500 kg;
- binder (cement) – 50–70 kg;
- mixing water – 350 l.

3. An analytical model is recommended for determining the efficiency of mining by comparing options for the development of deposits (including man-made), taking into account costs at all stages, differing in cost and to protect the population living in the zone of influence of mountain objects. Including expenses for environmental protection, rehabilitation of contaminated and disturbed territories, human health, etc.

4. The proposed technology is used by the SE «Ukr R&D Institute for IndTech» in the feasibility study for the construction of the enterprise on the basis of the Novokostiantynivka ore deposit (SE «EastOMP», Ukraine). So, with the production capacity of the enterprise 1,500 thousand tons/year, 50–55 % of the tailings are used for laying the underground mined space (830 thousand tons/year), and the rest connected with cementing material is stored in a storage (670 thousand tons/year).

Acknowledgement

The specified technology was performed with the participation of Yu. Tarkhin, N. Khudoshyna, L. Lyashenko, A. Skotarenko.

References

1. Yuan, Y., Bolan, N., PrévotEAU, A., Vithanage, M., Biswas, J. K., Ok, Y. S., Wang, H. (2017). Applications of biochar in redox-mediated reactions. *Bioresource Technology*, 246, 271–281. doi: <http://doi.org/10.1016/j.biortech.2017.06.154>
2. Lomonosov, G. G., Polonik, P. I., Abdalakh, Kh. (200). Sovershenstvovanie tekhnologii ochistnykh robot na osnove primeneniia pastoobraznykh zakladochnykh materialov. *Gornii zhurnal*, 2, 21–23.
3. Chernov, A. P. (Ed.) (2001). *Dobycha i pererabotka uranovykh rud v Ukraine*. Kyiv: Adef – Ukraina, 238.
4. Kvitka, V. V., Sergeev, V. E., Troter, K. et. al. (2001). Tverdeuschie zakladochnye smesi povyshennoi plotnosti/ (firma GMSZ, Avstraliia). *Gornii zhurnal*, 5, 33–35.
5. Lottermoser, B. (2012). *Mine Wastes: Characterization, Treatment and Environmental Impacts*. New York: Springer, 400.
6. Maanju, S. K., Saha, K. (2013). Impact of Mining Industry on Environmental Fabric – A Case Study of Rajasthan State in India. *IOSR Journal Of Environmental Science, Toxicology And Food Technology*, 6 (2), 8–13. doi: <http://doi.org/10.9790/2402-0620813>

7. Chowdhury, S. R., Yanful, E. K., Pratt, A. R. (2014). Recycling of nickel smelter slag for arsenic remediation – an experimental study. *Environmental Science and Pollution Research*, 21 (17), 10096–10107. doi: <http://doi.org/10.1007/s11356-014-2892-x>
8. Modaihsh, A. S., Mahjoub, M. O., Nadeem, M. E. A., Ghoneim, A. M., Al-Barakah, F. N. (2016). The Air Quality, Characterization of Polycyclic Aromatic Hydrocarbon, Organic Carbon, and Diurnal Variation of Particulate Matter over Riyadh City. *Journal of Environmental Protection*, 7 (9), 1198–1209. doi: <http://doi.org/10.4236/jep.2016.79107>
9. Golik, V., Komashchenko, V., Morkun, V. (2015). Feasibility of using the mill tailings for preparation of self-hardening mixtures. *Metallurgical and Mining Industry*, 3, 38–41.
10. Beiyuan, J., Awad, Y. M., Beckers, F., Tsang, D. C. W., Ok, Y. S., Rinklebe, J. (2017). Mobility and phytoavailability of As and Pb in a contaminated soil using pine sawdust biochar under systematic change of redox conditions. *Chemosphere*, 178, 110–118. doi: <http://doi.org/10.1016/j.chemosphere.2017.03.022>
11. Soroka, M. N., Savelev, Iu. Ia. (2004). Perspektivy utilizacii khvostov gidrometallurgicheskogo peredela i droblennykh gornykh porod v vyrabotannoe prostranstvo uranodobyvauschikh shakht Ukrainy. *Metallurgicheskaiia i gornorudnaia promyshlennost*, 5, 91–94.
12. Gusev, Iu. P., Berezikov, E. P., Krupnik, L. A. et. al. (2008). Resursosberegaiushchie tekhnologii dobychi rudy na Malevskom rudnike Zyrjanovskogo GOKa (AO «Kazcink»). *Gornii zhurnal*, 11, 20–22.
13. Kutepov, Iu. I., Kutepova, N. A., Zharikov, V. P. (2011). Inzhenerno–geologicheskoe i ekologicheskoe obosnovanie rekultivacii gidrootvalov Kuzbassa. *Gornii informacionno-analiticheskii biulleten*, 2, 34–42.
14. Trubetskoy, K. N., Kaplunov, D. R., Ryl'nikova, M. V. (2012). Problems and prospects in the resource-saving and resource-reproducing geotechnology development for comprehensive mineral wealth development. *Journal of Mining Science*, 48 (4), 688–693. doi: <http://doi.org/10.1134/s1062739148040132>
15. Averianov, K. A., Angelov, V. A., Akhmedianov, I. Kh., Ryl'nikova, M. V. (2012). Razvitie klassifikacii tekhnogennogo syria gornykh predpriiatii i obosnovanie tekhnologii ego aktivnoi utilizacii. *Gornii informacionno-analiticheskii biulleten*, 5, 208–213.
16. Lyashenko, V. I. (2014). Novye tekhnologii utilizacii khvostov gidrometallurgicheskogo proizvodstva v vyrabotannye prostranstva i khvostokhranilischa. *Izvestiia vuzov. Cvetnaia metallurgii*, 2, 52–58.
17. Lyashenko, V. I., Gurin, A. A. (2016). The Environmental Protection Technologies and Facilities for the Dust Suppression of the Tailing Dump Surfaces. Ferrous Metallurgy. *Bulletin of Scientific, Technical and Economic Information*, 4, 10–17.
18. Lyashenko, V. I., Golik, V. I. (2017). Scientific and engineering supervision of uranium production development. achievements and challenges. *Mining informational and analytical bulletin*, 7, 137–152. doi: <http://doi.org/10.25018/0236-1493-2017-7-0-137-152>
19. *Antofagasta zavershila stroitelstvo khvostokhranilischa na mednomolibdenovom rudnike Los-Pelambres v Chili*. Available at: <http://www.mineral.ru/News/34680.html>
20. Lyashenko, V. I. (2017). Development of the Scientific and Methodical Bases for Assessment of Efficiency of Nature Protection Technologies and Technical Means at the Ore Raw Materials Development and Processing. *Occupational Safety in Industry*, 9, 30–36. doi: <http://doi.org/10.24000/0409-2961-2017-9-30-36>
21. Lyashenko, V. I., Dyatchin, V. Z., Lisovoy, I. A. (2017). Improvement of Safety of Mining Operations on the Basis of Effective Management of Mining Waste and Crude Ore Processing. *Occupational Safety in Industry*, 11, 16–22. doi: <http://doi.org/10.24000/0409-2961-2017-11-16-22>
22. Lyashenko, V. I., Dyatchin, V. Z., Lisovoy, I. A. (2018). Increase of Environmental Safety of Mining Production on the Basis of Waste Utilization of Extraction and Processing of Ore Raw Materials. *Ecology and Industry of Russia*, 22 (4), 4–10. doi: <http://doi.org/10.18412/1816-0395-2018-4-4-10>
23. Dvoretzkyi, A. I., Lyashenko, V. I., Stus, V. P., Kovalenko, H. D. (2018). Vplyv uranovoi promyslovosti Prydniprovia na stan dovkillia. Problemy ta shliakhy yikh vyreshennia. *Ekolohichna bezpeka: problemy i shliakhy vyreshennia*. Kharkiv: FOP Stolarova I. P., 156–165.
24. Lyashenko, V. I., Chekushina, T. V., Lisovoy, I. A., Lisovaya, T. S. (2019). Environmental Safety in the Zone of Influence of Uranium Production. *Ecology and Industry of Russia*, 23 (3), 60–65. doi: <http://doi.org/10.18412/1816-0395-2019-3-60-65>
25. Krupskaya, L. T., Golubev, D. A., Rastanina, N. K., Filatova, M. Y. (2019). Reclamation of tailings storage surface at a closed mine in the Primorsky Krai by bio remediation. *Mining Informational and Analytical Bulletin*, 9, 138–148. doi: <http://doi.org/10.25018/0236-1493-2019-09-0-138-148>
26. Abashkina, T. S., Borodavko, F. F., Aksenov, S. G. (1991). A.S. No. 1627406 SSSR. *Sposob skladirovaniia otkhodov obogascheniia*. MPK: E02V 7/06; declared: 28.11.1988; published: 15.02.1991.
27. Volkov E. P., Anushenkov A. N. (2019). Developing the technology of mine stowing with processing tailings based hardening blends. *Izvestiya vysshikh uchebnykh zavedenii gornyi zhurnal*, 7, 5–13. doi: <http://doi.org/10.21440/0536-1028-2019-7-5-13>

Lyashenko Vasil, PhD, Senior Researcher, Head of Department, Research Department, State Enterprise «Ukrainian Research and Design Institute of Industrial Technology», Zhovti Vody, Dnepropetrovsk region, Ukraine, e-mail: ipt@iptz.org.ua, ORCID: <http://orcid.org/0000-0001-8361-4179>

Topolnij Fedor, Doctor of Biological Sciences, Professor, Department of General Agriculture, State Higher Educational Institution «Central Ukrainian National Technical University», Kropyvnytskyi, Ukraine, e-mail: topolnij@gmail.com, ORCID: <http://orcid.org/0000-0002-3363-4646>

Dyatchin Vladimir, PhD, Associate Professor, Department of Management and Social Work, Regional Municipal Higher Educational Institution «Institute of Entrepreneurship «Strategy», Zhovti Vody, Dnepropetrovsk region, Ukraine, e-mail: dsveta49@i.ua, ORCID: <http://orcid.org/0000-0003-1935-2746>