

DOI: 10.13140/RG.2.1.3240.6480

УДК 005.8

Andrey Oganov

Master of project management, certified project management professional (PMP PMI & IPMA C),
Deputy Chief of service on operational management major ammonia pipeline, ORCID: 0000-0002-2492-2654
Ukrainian state company "Ukrkhimtransamiak", Kiev

Viktor Gogunsky

Doctor of Technical Sciences, Professor, Head of Department of Vitality protection systems management,
ORCID: 0000-0002-9115-2346
Odessa national polytechnic university, Odessa

Olga Sherstyuk

Graduate student, ORCID: 0000-0002-0482-2656
Odessa national polytechnic university, Odessa

ANALYSIS OF WORK-LOAD RATE OF PORTFOLIO MANAGER BY MEANS OF MARKOVIAN MODEL OF STATES

Abstract. *Current conditions of most project-oriented businesses based activities are related to the implementation of projects requires the management of these companies develop and apply appropriate procedures, methods and management techniques. The complexity of using classical approaches arises from the fact that the activities of design organizations is in many ways a unique non-recurring process. The practice of these companies shows that much attention from their owners paid not only to the global strategic objectives, but the current results of operations. In real situations, work portfolio management takes place in a high degree of uncertainty: the time of admission of projects, time and costs of their implementation, as well as other factors are random variables with specified or unknown distribution laws. On the basis of the standard portfolio management Project Management Institute USA (PMI) analyzed the portfolio management process using Markov chains for discrete states of the system. Identified processes (state) in which the portfolio manager is busy most of the time. Markov model state changes to determine the loading of a portfolio manager at various stages of portfolio management, which makes it possible to use these data in determining the KPI project managers when evaluating their work.*

Keywords: *project; portfolio management; team; project management office; Markov's chain; transition probabilities*

Problem statement

Year by year C-level managers at the enterprises pay more attention to the quality of portfolio selection and management. In the situation of scarcity of resources it is vital for the entities not only to do projects "right" so to timely achieve the results, but also to launch the "right" projects at the proper time. For this purpose, entities are recommended to create the Project Management Office (PMO) [1].

Whether those PMO – whose responsibility is to bring projects to success – have been introduced at the enterprise or not, or better portfolio management is achieved through appointment of certain managers, the success of a portfolio depends on the level of expertise of the portfolio managers as well as of the level of maturity of the organization in project management.

The size of portfolios depends on the size of the organization itself, be that the general number of projects and works or their value. Therefore when the size of a portfolio is insignificant, the portfolio manager

should not be appointed from among designated managers, but someone from among middle rank managers to combine his regular duties with portfolio managing activities. In this circumstance the CEO or CIO of the entity wants to be sure that his portfolio manager has a full work-load and effectively fulfills the duties, to justify receiving "good" salary.

Modern companies have been long using key performance indicators (KPI) for the purpose of motivation for their employees, and for determining the size of bonuses at successful performance of work.

To define KPI for portfolio managers it does necessary to have the idea of approach to portfolio management as such, the knowledge of necessary processes of portfolio management; understand what they deal with, why and for how long they are engaged in certain processes.

Analysis of the recent publications

In order to develop successfully the companies need not only to render high quality services or make high quality production, but also to improve and

modernize them, to create new services and products, gaining competitive advantage through innovations. For this purpose it is necessary to launch programs and projects which will yield expected results. This in turn requires having the staff of managers at hand who are capable to manage programs and projects well. Besides, a set of conditions is to be created in the organizations and proper environment attained for successful implementation of projects, seeking to bring the company project management into maturity [2].

The recent study has shown [3-6] that the majority of companies owe their success to all-round implementation of PMO which are reporting directly to C-level managers and “communication-up” is sustained by project managers and resource managers. Community of Practitioners of PMI together with PMO Subject Matter Experts (SME) have distinguished 5 kinds of PMO structures as follows:

1. Organizational Unit PMO/ Business Unit PMO/ Divisional PMO/ Departmental PMO; 2. Project-Specific PMO/ Project Office/ Program Office;

3. Project Support/ Services/ Controls Office or PMO; 4. Enterprise/ Organization-wide/ Strategic/ Corporate/ Global PMO; 5. Center of Excellence/ Center of Competency [7]. The PMO highest level that returns the highest dividends to the enterprises is Strategic PMO.

Of course, implementation of Strategic PMO can run into opposition from heads of divisions, project managers, and the staff of existing structures motivated by personal, mercantile interests of certain employees [8]. But there are ways of mitigation of Strategic PMO implementation at the enterprise with use of tools of the theory of constraints [9, 10].

At the enterprise where Strategic PMO is being introduced, all processes of preparation, definitions,

prioritization of portfolios of the enterprise are employees’ concern and responsibility. Otherwise portfolio manager should be appointed, who will be responsible for that. In both cases the success of a portfolio depends on the correct application of portfolio management processes which are recommended in the form of good practices by professionals from all over the world being the attachments to PMI portfolio management standards [11]. Under the auspices of International Organization of Standardization (ISO), special committee ISO/TC 258 is established to create international standards Project and Programme Portfolio Management (ISO/DIS 21502) and Guidance on governance of projects, programmes and portfolios (ISO/WD 21503). Most probably, in likelihood with standard for project management ISO 21500 the above mentioned standards will become adaptation of the version of ANSI standards of PMI to the international ISO standard.

PMI standards being the basis for training and certifying experts in 170 countries of the world, ISO standards represent the adapted version of PMI standards.

Therefore it would be relevant to study the measure of portfolio manager with a view to application in practice of portfolio management processes as per PMI standard [11] which is given in table 1.

Research objective

The purpose of this research is to create a model of portfolio manager work-load at different stages of portfolio management processes according to the standard [11] with application of Markovian chains for further use with KPI. At the same time the obligatory requirement is the compliance with the specialty passport according to the recommended directions listed in [12].

Table 1 – Portfolio Management Process Groups and Knowledge Areas Mapping

Knowledge Areas	Process Groups		
	Defining Process Group	Aligning Process Group	Authorizing and controlling Process Group
Portfolio Strategic Management	4.1 Develop Portfolio Strategic Plan 4.2 Develop Portfolio Charter 4.3 Define Portfolio Roadmap	4.4 Manage Strategic Change	
Portfolio Governance Management	5.1 Develop Portfolio Management 5.2 Define Portfolio	5.3 Optimize portfolio	5.4 Authorize Portfolio 5.5 Provide Portfolio Oversight
Portfolio Performance Management	6.1 Develop Portfolio Performance Management Plan	6.2 Manage Supply and Demand 6.3 Manage Portfolio Value	
Portfolio Communication Management	7.1 Develop Portfolio Communication Management Plan	7.2 Manage Portfolio Information	
Portfolio Risk Management	8.1 Develop Portfolio Risk Management Plan	8.2 Manage Portfolio Risks	

Discussion

Markovian chains for definition of probabilities of conditions in various systems were described by different researchers in their articles [13-17]. Prior to begin our research we will display in fig. 1 the diagram of portfolio management in the form of transitions during interaction of the processes described in the standard [11].

We will consider system S in fig. 1 which can be with some probability of $P(k)$ in one of conditions of S_i $\{i=1, 2, \dots, 17\}$ and in certain (discrete) time points of $t_k \{i=1, 2, \dots, k\}$ to pass from a condition of S_i into condition of S_k with probability of $P_{ik} \cdot P_i$.

Casual process which proceeds in system S is called Markovian if it possesses the following property: for each time point of t_0 probability of any condition of system in the future (at $t > t_0$) depends only on its state in the present (at $t = t_0$) and doesn't depend on when and how the system came to this state (i.e. how the process developed in the past). The process that take place in the system can be presented as a sequence (chain) of events called Markovian chain where for each step the probability of transition from any condition of S_i to any condition of S_j does not depend on when and how the system came to a condition of S_i .

We will display the system from fig. 1 by means of the directed graph in fig. 2, where S_i is vertices of the graph corresponding to certain conditions (processes) of the system: $\{(4.1) \rightarrow S_4; (4.2) \rightarrow S_6; (4.3) \rightarrow S_5; (4.4) \rightarrow S_6; (5.1) \rightarrow S_8; (5.2) \rightarrow S_{10}; (5.3) \rightarrow S_9; (5.4) \rightarrow S_{13}; (5.5) \rightarrow S_{11}; (6.1) \rightarrow S_7; (6.2) \rightarrow S_{12}; (6.3) \rightarrow S_3; (7.1) \rightarrow S_{14}; (7.2) \rightarrow S_{15}; (8.1) \rightarrow S_{16}; (8.2) \rightarrow S_{17}\}$.

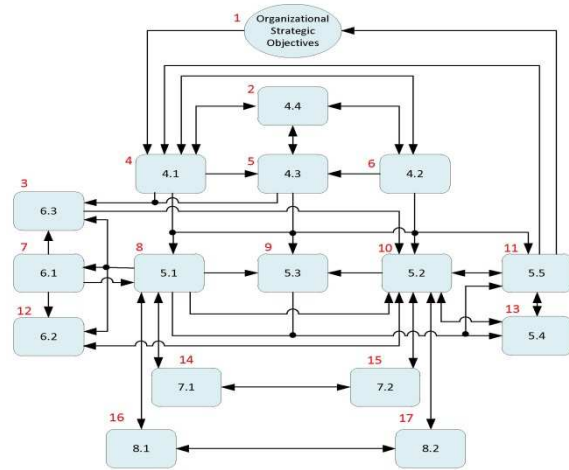

Figure 1 – Diagram of portfolio management

The vertices are connected between themselves by focused arches (edges of the graph), representing the directions of transitions between conditions of the system (processes). Thus for transformation scheme of states in a Markovian chain from fig. 1 we need to add possibility of system's "delay" in each of conditions of S_i $\{i=1, 2, \dots, 17\}$ in the form of additional communications $\pi_{i,i}$.

The outward arrows proceeding from vertices of graph mean probability of transition from current state of S_i , and inward arrows represent probability of transition to this condition of S_i .

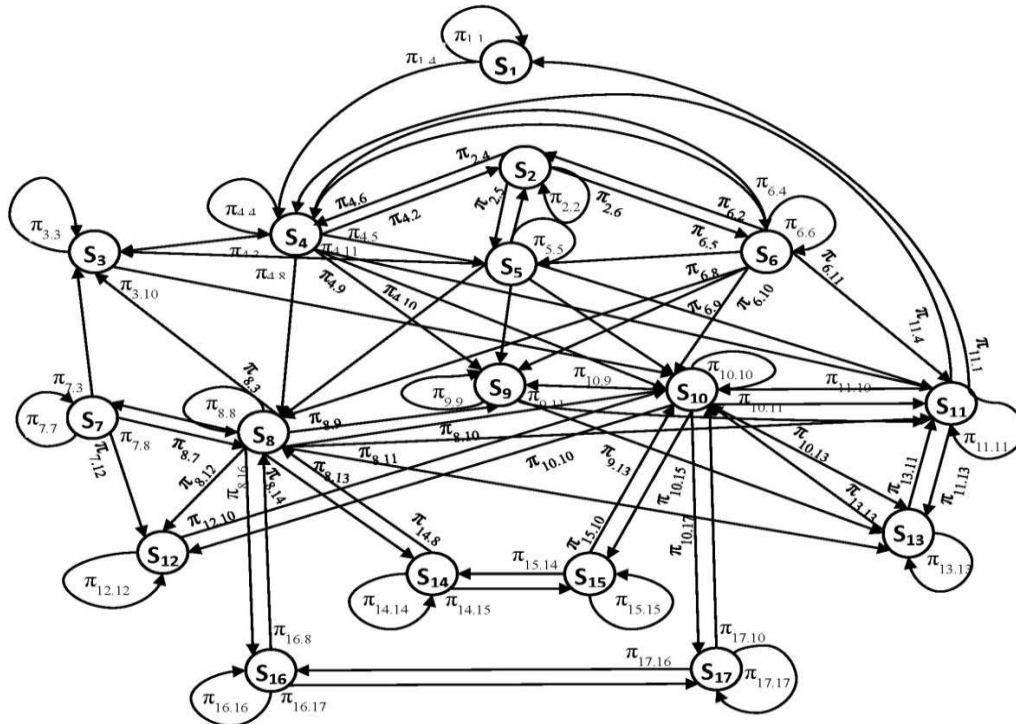

Figure 2 – Directed graph of a Markov's chain

The outward arrows proceeding from vertices of graph mean probability of transition from current state of S_i , and inward arrows represent probability of transition to this condition of S_i .

Direct graph of the system with 17 vertices can be presented in the form of a matrix 17×17 which elements are probabilities of transitions of π_{ij} between vertices of the graph. This kind of matrix is called a matrix of transitional probabilities. Elements of the matrix have to meet the following conditions:

$$0 \leq \pi_{ij} \leq 1 \tag{1}$$

$$\sum_{j=1}^n \pi_{ij} = 1 \tag{2}$$

Condition (1) – usual property of probabilities and condition (2) means that the system S certainly either passes from any condition of S_i into other state, or remains S_i . The π_{ij} elements of a matrix of $|\pi_{ij}|$ represent probabilities of transitions in system during one step.

In Markovian chain with time change (k step) distribution of probabilities of states $\{p_1(k), p_2(k) \dots p_m(k)\}$ varies. The distribution of probabilities on any following ($k+1$) step is calculated with the well-known formula of a total probability. The common decision of Markovian chain with 17 states looks as follows:

$$\begin{pmatrix} p_1(k+1) \\ p_2(k+1) \\ \cdot \\ \cdot \\ p_{16}(k+1) \\ p_{17}(k+1) \end{pmatrix}^T = \begin{pmatrix} p_1(k) \\ p_2(k) \\ \cdot \\ \cdot \\ p_{16}(k) \\ p_{17}(k) \end{pmatrix}^T \begin{pmatrix} \pi_{1,1} & \pi_{1,2} & \cdot & \cdot & \cdot & \pi_{1,16} & \pi_{1,17} \\ \pi_{2,1} & \pi_{2,2} & \cdot & \cdot & \cdot & \pi_{2,16} & \pi_{2,17} \\ \cdot & \cdot & \cdot & \cdot & \cdot & \cdot & \cdot \\ \cdot & \cdot & \cdot & \cdot & \cdot & \cdot & \cdot \\ \cdot & \cdot & \cdot & \cdot & \cdot & \cdot & \cdot \\ \pi_{16,1} & \pi_{16,2} & \cdot & \cdot & \cdot & \pi_{16,16} & \pi_{16,17} \\ \pi_{17,1} & \pi_{17,2} & \cdot & \cdot & \cdot & \pi_{17,16} & \pi_{17,17} \end{pmatrix},$$

where T is a transposing symbol.

Each row of a matrix $|\pi_{ij}|$ is to satisfy the following condition:

$$\sum_{j=1}^{17} \pi_{ij} = 1, \quad \{i = 1, 2, \dots, 17\}, \tag{3}$$

where $m = 17$ is a number of possible conditions of system.

The sum of probabilities of conditions of $p_i(k)$ on each step of k is equal to:

$$\sum_{i=1}^m p_i(k) = 1, \tag{4}$$

where $p_i(k)$ – probability of i state on k step.

For a transition matrix we will determine values of conditional probabilities through expert method, by obtaining data from portfolio managers who apply processes of the standard [11] in their work. As a result we will receive a matrix in fig. 3.

Matrix of transitions allows developing a model of Markovian chain with which to carry out the forecast of a condition of the system for some steps onward. The results of the modeling a portfolio management system is given in fig. 4 where it is possible to determine a work-load of portfolio manager at different stages of portfolio management per each process.

At the initial stages of management of a portfolio (up to 3-rd step on model) most part of portfolio manager's time is spent on developing strategic portfolio plan $p_4(k)$, defining portfolio road map $p_5(k)$ and developing portfolio charter $p_6(k)$.

At later stages (from the 10th step on model) most part of time is consumed by the following processes on decrease: $p_{10}(k)$ – define portfolio; $p_{13}(k)$ – authorize portfolio; $p_9(k)$ – optimize portfolio; $p_{15}(k)$ – manage portfolio information; $p_{11}(k)$ – provide portfolio oversight; $p_{12}(k)$ – manage supply and demand; $p_{17}(k)$ – manage portfolio risks.

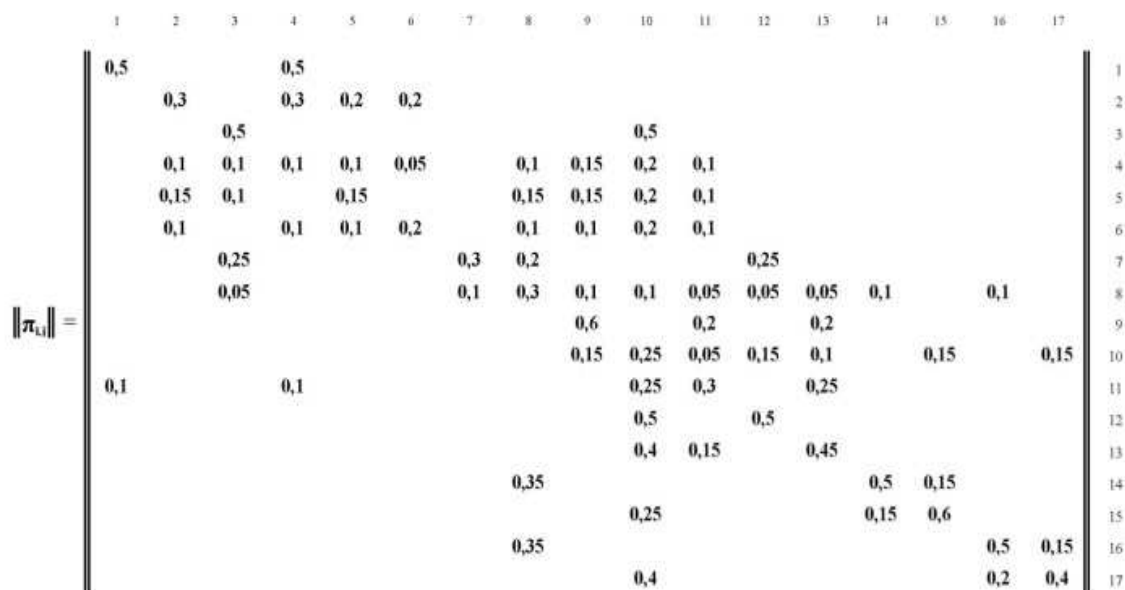

Figure 3 – Matrix of transition probabilities with estimates of expert

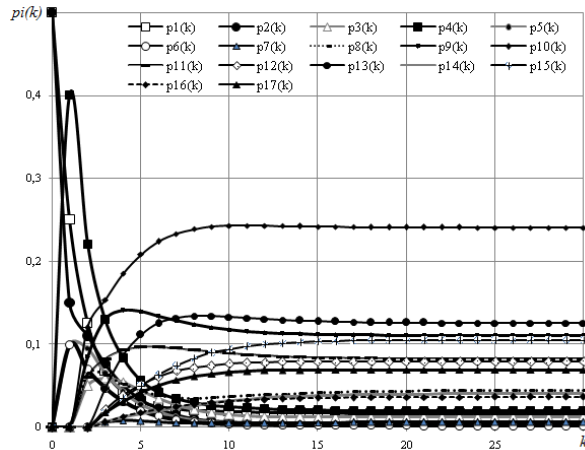

Figure 4 – Change of probabilities of conditions of portfolio management system

As is known, the transition probability matrix shows the level of technological maturity of the organization [18, 19]. In relation to the portfolio team – is its potential characteristic or property to perform the work of the portfolio of projects in accordance with existing environmental conditions and the level of competence of team players [20]. In other words, different portfolio teams will have different transition matrices for the same portfolio of projects. This is a consequence of the known law S.D. Bushuev's [14]. Therefore, if the transition matrix $|\pi_{ij}|$ defined during the portfolio, long before its closure can be assessed by the portfolio activity.

Conclusions

The presented Markovian model of change of states allows defining the measure of time portfolio manager spends on different steps of portfolio management. This will give the chance to use those data when determining KPI of project managers at an assessment of their work.

References

- Oganov, A.V., & Gogunsky, V.D. (2013). *The need for implementation of the project management office. Information technologies in education, science and production*, ed. Odessa, Ukraine: ONPU, № 4(5), 57-61.
- Organizational project management maturity model (OPM3)*. (2012). Project Management Institute. Third edition.
- PMI's Pulse of the Profession™. The High Cost of Low Performance*. (2013). Project Management Institute, Inc. Pulse of the Profession™, March 2013.
- Insights and Trends: Current Portfolio, Program and Project Management Practices*. (2012). PricewaterhouseCoopers.
- Are You Ready to Transform Your PMO?* (2011). Forrester Research.
- PMI's Pulse of the Profession™ In-Depth Report: The Impact of PMOs on Strategy Implementation*. (2013). Project Management Institute, Inc. Pulse of the Profession™, July 2013.
- PMI's Pulse of the Profession™. PMOs Frameworks*. November 2013.
- Oganov, A.V., & Gogunsky, V.D. (2013). *Use the Theory of Constrains in PMO implementation at the organization. GESJ: Computer Science and Telecommunications*, No. 4(40), 59-65.
- Oganov A.V., & Gogunsky V.D. (2014). *The Evaporated Cloud Diagram for conflict of implementation of Strategic PMO at the Entities. Management of development of complex systems*. Kyiv, Ukraine: KNUCA, 36 – 41.
- Lizunov, P.P., Beloshchitsky, A.A., & Beloshchitskaya, S.V. (2011). *Design vector control higher education institutions / Management of development of complex systems*. Kyiv, Ukraine: KNUCA: 6, 135 – 139.
- The standard for portfolio management* (2012). Project Management Institute. — Third edition.
- Bushuev, S. D., Gogunsky, V.D., & Koshkin, K.V. (2012). *Directions dissertation research in the specialty "Management of projects and programs". Management of development of complex systems*. Kyiv, Ukraine: KNUCA, 12, 5 – 7.
- Rudenko, S.V., Romanenko, M.V., Katunina, O.G., & Kolesnikova, K.V. (2012). *Development of the Markov model state changes in patients projects providing medical services. Management of development of complex systems*. Kyiv, Ukraine: KNUCA, 12, 86 – 89.
- Kolesnikova, K.V. (2014). *Development of the theory of project management: justification of the law of initiation of projects. Management of development of complex systems*. Kyiv, Ukraine: KNUCA, 14, 86 – 89.
- Vaysman, V. A., Kolesnikova, E. V., & Lukianov, D. V. (2012). *The planar graphs closed cycles determination method. Proceedings of Odes. Polytechnic. Univ, Odessa, Ukraine: ONPU, 1(38), 222 – 226*.
- Kolesnikova, K.V., Vaysman, V.A., & Velichko, S.A. (2012). *Markov model development status of the project –driven organizations. Current technology in mechanical engineering: Collected Works, Kharkov, Ukraine: NTU "KPI", 7, 217 – 222*.
- Kolesnikova, K.V., & Negri, A.A. (2013). *Transformation of cognitive maps in Markovian processes for projects of creation of the software. Management of development of complex systems*. Kyiv, Ukraine: KNUCA, 15, 30 – 35.
- Kolesnikova, K.V. (2013). *The development of the theory of project management: Explanation law K.V. Koshkin to complete projects. Management of development of complex systems*. Kyiv, Ukraine: KNUCA, 16, 38 – 45.
- Kolesnikova, K.V. (2014). *Method for determination of the ergodicity of a directed graph of project management. Management of development of complex systems*. Kyiv, Ukraine: KNUCA, 20, 27 – 31.
- Beloshchitsky, A. A. (2012). *Management problems in the methodology of design vector control of the educational environment. Management of development of complex systems*. Kyiv, Ukraine: KNUCA: 9, 104 – 107.

Article received editorial board 07.04.2015

Reviewer: Doctor of Engineering, Professor Rudenko S.V., Odessa National Maritime University, Odessa.

Оганов Андрій Валерійович

Магістр, сертифікований проектний менеджер PMP PMI USA та IPMA Level C UPMA,

Заступник начальника служби оперативного управління магістрального аміакопроводу, *ORCID: 0000-0002-2492-2654*
Державне підприємство «Укрхімтрансміак», Київ

Гогунський Віктор Дмитрович

Доктор технічних наук, професор, завідувач кафедри управління системами безпеки життєдіяльності, *ORCID: 0000-0002-9115-2346*

Одеський національний політехнічний університет, Одеса

Шерстюк Ольга Ігорівна

Аспірант кафедри управління системами безпеки життєдіяльності, *ORCID: 0000-0002-0482-2656*

Одеський національний політехнічний університет, Одеса

**АНАЛІЗ НАВАНТАЖЕННЯ МЕНЕДЖЕРА ПОРТФЕЛЯ ПРОЕКТІВ
ЗА ДОПОМОГОЮ МАРКОВСЬКОЇ МОДЕЛІ СТАНІВ**

Анотація. Як правило робота портфельного менеджменту відбувається в умовах високого ступеня невизначеності: моменти надходження проектів, час і витрати їх виконання, а також інші фактори є випадковими величинами із заданими або невідомими законами розподілу. Дана стаття присвячена розвитку методів сценарного управління для поточного управління проектно-орієнтованим підприємством шляхом використання марковських моделей. На основі стандарту з управління портфелями інституту проектного менеджменту США (PMI) виконано аналіз процесів управління портфелями за допомогою марковських ланцюгів для дискретних станів системи. Виявлено процеси (стати), в яких керівник портфеля проектів зайнятий більший період часу.

Ключові слова: проект; управління портфелем; команда; офіс управління проектами; ланцюг Маркова; перехідні ймовірності

Оганов Андрей Валерьевич

Магістр, сертифікований проектний менеджер PMP PMI USA та IPMA Level C UPMA,

Заместитель начальника службы по оперативному управлению магистрального аммиакопровода, *ORCID: 0000-0002-2492-2654*

Государственное предприятие «Укрхимтрансмиак», Киев

Гогунский Виктор Дмитриевич

Доктор технических наук, профессор, заведующий кафедрой управления системами безопасности жизнедеятельности, *ORCID: 0000-0002-9115-2346*

Одесский национальный политехнический университет, Одесса

Шерстюк Ольга Игоревна

Аспирант кафедры управления системами безопасности жизнедеятельности, *ORCID: 0000-0002-0482-2656*,

Одесский национальный политехнический университет, Одесса

**АНАЛИЗ ЗАГРУЗКИ МЕНЕДЖЕРА ПОРТФЕЛЯ ПРОЕКТОВ
С ПОМОЩЬЮ МАРКОВСКОЙ МОДЕЛИ СОСТОЯНИЙ**

Аннотация. В реальных ситуациях работа портфельного менеджмента протекает в условиях высокой степени неопределенности: моменты поступления проектов, время и затраты их выполнения, а также прочие факторы являются случайными величинами с заданными или неизвестными законами распределения. На основании стандарта по управлению портфелями института проектного менеджмента США (PMI) выполнен анализ процессов управления портфелями с помощью марковских цепей для дискретных состояний системы. Выявлены процессы (состояния), в которых руководитель портфеля проектов занят большую часть времени.

Ключевые слова: проект; управление портфелем; команда; офис управления проектами; цепь Маркова; переходные вероятности

Link to publication

- APA Oganov, A.V., Gogunsky, V.D., & Sherstyuk, O.I. (2015). Analysis of work-load rate of portfolio manager by means of markovian model of states. *Management of Development of Complex Systems*, 22 (1), 13 – 18. [dx.doi.org/10.13140/RG.2.1.3240.6480](https://doi.org/10.13140/RG.2.1.3240.6480)
- ГОСТ Оганов, А.В. Аналіз навантаження менеджера портфеля проектів за допомогою марківської моделі станів [Текст] / А.В. Оганов, В.Д. Гогунський, О.І. Шерстюк // Управління розвитком складних систем. – 2015. – № 22 (1). – С. 13 – 18. [dx.doi.org/10.13140/RG.2.1.3240.6480](https://doi.org/10.13140/RG.2.1.3240.6480)