

Аналіз задач по підвищенню енергоефективності систем електричної тяги вказує на необхідність впровадження нових технологій, а саме сучасного рухомого складу з тяговим асинхронним електроприводом та тягових підстанцій за новими технологіями. Для вирішення даного класу задач визначено потребу в комплексній імітаційній моделі системи електричної тяги з необхідністю забезпечення достатнього рівня її достовірності.

Наведено деталізацію алгоритмів розрахунку параметрів для розробки імітаційної моделі комплексної електричної тягової системи метрополітену, яка складається з підсистем електропостачання, електроприводу рухомого складу і механічної частини тягової передачі.

В середовищі Matlab/Simulink на основі відомих реальних і уточнених розрахункових параметрів розроблено імітаційну модель системи тягового електропостачання метрополітену з двостороннім живленням двох шляхів. Розроблена імітаційна модель сучасного тягового електроприводу вагонів метрополітену з векторною системою керування асинхронного електроприводу і одномаховою механічною частиною, що здатна враховувати вплив коефіцієнта зчеплення.

Проведене порівняння результатів імітаційного моделювання динамічних процесів з осцилограмами реальних режимів роботи метрополітену підтвердило адекватність моделі досліджуваному об'єкту. Відповідність отриманих шляхом моделювання результатів підтверджується осцилограмами аналізу напруги і струму контактної мережі, а також характеристиками режимів тяги і гальмування рухомого складу.

Змодельовані процеси роботи системи електропостачання, нестационарного режиму за погіршення умов зчеплення та режиму рекуперативного гальмування з передачею енергії іншим поїздам.

Використання розробленої моделі комплексної системи електричної тяги сприятиме більш повному дослідженню взаємного впливу елементів системи електричної тяги. Це дозволить підвищити ефективність прийняття технічних рішень в рамках виконання вимог щодо забезпечення безпеки руху, запобігання виникнення порушень нормальної роботи та зниженню експлуатаційних витрат

Ключові слова: імітаційне моделювання, метрополітен, тягове електропостачання, електропоїзд, тяговий асинхронний електропривод

UDC 621.31:629.423.2

DOI: 10.15587/1729-4061.2019.154520

COMPREHENSIVE APPROACH TO MODELING DYNAMIC PROCESSES IN THE SYSTEM OF UNDERGROUND RAIL ELECTRIC TRACTION

S. Yatsko

PhD, Associate Professor*

E-mail: ua.yatsko@gmail.com

B. Sytnik

PhD, Associate Professor

Department of Information Technologies**

Y. Vashchenko

PhD, Senior Lecturer*

A. Sidorenko

Postgraduate student*

B. Liubarskyi

Doctor of Technical Sciences, Professor

Department of Electrical Transport and Diesel Locomotive***

I. Veretennikov

PhD, Associate Professor

Department of

Information Technologies and Systems of Wheeled and Tracked Vehicles named after O. O. Morozova***

M. Glebova

PhD, Associate Professor

Department of Alternative Electric Power Engineering and Electrical Engineering

O. M. Beketov National University of

Urban Economy in Kharkiv

Marshala Bazhanova str., 17, Kharkiv, Ukraine, 61002

*Department of Electric Power Engineering, Electrical Engineering and Electromechanics**

**Ukrainian State University of Railway Transport

Feierbakha sq., 7, Kharkiv, Ukraine, 61050

***National Technical University

«Kharkiv Polytechnic Institute»

Kyrpychova str., 2, Kharkiv, Ukraine, 61002

1. Introduction

The main components to enhance the safety and energy efficiency of underground rail systems are measures to prevent the occurrence of disruptions in normal operation, to reduce energy consumption for traction of trains, as well as the cost of technical maintenance and repairs. Implementation of the specified measures implies the use of new

technologies and solutions, capable to maximally automate the process of transportation.

At the same time, the introduction of such technologies is impossible without a sufficient level of analysis and study into the features of processes, the lack of which could, on the contrary, worsen the reliability and increase the costs.

A complete comprehensive analysis of capabilities, prospects, as well as the search for ways to resolve this kind of

tasks, could be conveniently performed using mathematical and simulation models of rolling stock and the system of its power supply. Under conditions of introducing rolling stock with a promising traction electric drive [1] and traction substations, based on new technologies [2], this task is especially relevant.

2. Literature review and problem statement

The electric supply system and the electric rolling stock of underground rail system form a complex multi-factor system in which there occur the interdependent transient electromagnetic processes. Studying respective processes contributes to solving optimization problems related to control over rolling stock [3], reducing losses by improving the efficiency of traction equipment [4], enhancing indicators of quality and consumption modes of electrical energy [5]. That makes it possible to develop and improve technologies for onboard and stationary storage devices [6], protection against emergency modes and emergency situations [7] devices that improve electromagnetic compatibility [8], and others.

At present, when addressing this list of tasks, a major source of information in most cases is still the experimental analytical and statistical studies [9]. The disadvantage of such approaches is that they are limited in the universality of problems being solved, they lack techniques to measure the “touch points” at subsystems (such as the contact rail – the input circuit of a power scheme, the contact between a wheel and a rail), as well as the high cost of research.

Methods of mathematical modeling make it possible to overcome these drawbacks. Modeling methods can be implemented by using structural linearized models [10], models applying equations of state variables [11], or by employing the nonlinear energy units, as, for example, units from the library SimPowerSystems in the programming environment Matlab/Simulink [12].

In this case, most studies imply modeling of only individual structural elements within the electric traction system with a simplified representation of others [13]. In such cases, it does not make it possible to fully take into consideration the interdependence of transient processes that occur in one subsystem affecting other subsystems, as well as the entire system in general.

Solving the problem involves approaches to modeling, which are based on events at which the structure of the model may vary depending on the events that occur in the process of simulation [14]. Such approaches suggest a formalized graphical cause and effect representation based on energy macroscopic representation (EMR) [15]. A disadvantage of this type of modeling is the necessity to know quite well the cause and effect relations, which are not entirely known, especially under conditions of insufficient experience related to the operation of rolling stock with a traction induction electric drive at underground rail systems.

Thus, the main techniques to study complex energy systems are, up to now, the methods of imitational modeling and simulation [16]. The obvious advantages of imitational simulation include: a possibility to solve problems that cannot be resolved using simpler methods and prevent studying an actual object, as well as a possibility to rapidly analyze various variants.

However, along the path to the fully-fledged implementation of qualitative imitational models one runs into obstacles such as a shortage of universal models, including imitational models of currently introduced electric rolling stock and systems of electricity supply. At the same time, there must be accuracy in the assessment of work of the actually operating electric traction system in accordance with the assigned tasks.

3. The aim and objectives of the study

The aim of this work is to develop an imitational model of the underground electric traction system using an integrated approach to the modeling of dynamic processes. That would make it possible to apply the developed model for a more complete study into the mutual influence of elements in the system of electrical traction, thereby making effective technical decisions in order to prevent the occurrence of disruptions in normal operation and to bring down operating costs.

To accomplish the aim, the following tasks have been set:

- to develop an imitational model of the system of traction DC power supply with a two-way power for two tracks;
- to develop an imitational electromechanical model of the rolling stock of underground cars with a vector system of control over the induction drive;
- to assess compliance of the simulated systems to an actual object of research and to assess patterns in energy exchange under the modes of traction and recuperative braking.

4. Power supply system of rolling stock

Underground rail system consumers are powered from an urban electricity grid by a three-phase alternating current at frequency 50 Hz through cable lines with voltage 6 or 10 kV from two independent power sources – main (district) substations within the electricity grid.

Underground rail systems exploit a decentralized system of electricity supply to a traction network with a two-way power supply to the contact rail from two traction substations. When a two-way power supply is used, cars in electric rolling stock consume energy from two traction substations. In this case, the character of feeders work at substations, as well as power consumption by electric rolling stock, is essentially of the pulsed character, which is illustrated by the oscillogram shown in Fig. 1. In this case, values for the traction current reach a magnitude of the order of 2300 A, at average current I_{μ} the order of 200 A. An extremely uneven schedule of power consumption is one of the main reasons for the increased losses in the system of energy supply. Negative indicators for current can indicate both the process of recuperation and, in a given case, the flow of power through the buses at two paths of the traction network, powered by the same traction substations.

Fig. 2 shows a structural diagram of the underground rail two traction substations that feed two paths of the traction network. The diagram schematically shows Electric rolling stocks ERS 1 and ERS 2, and the distribution of power current among traction substations:

$$I_{ERS1}=I_{A1}+I_{B1}, I_{ERS2}=I_{A2}+I_{B2}. \quad (1)$$

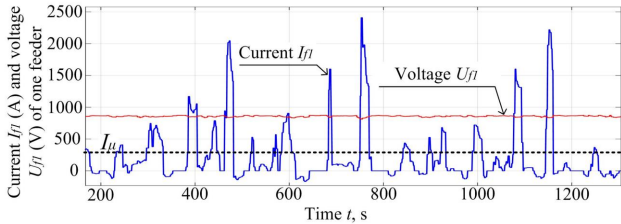

Fig. 1. Oscillograms of the actual current of load and voltage of the feeder at an underground rail traction substation

A replacement circuit of the external system of power supply (urban electricity grid) for each traction substation can be represented in the form of a three-phase AC power source with equivalent internal active resistance r_{es} and inductance L_{es} . Parameters for the replacement circuit of an external electrical supply system can be defined using the power of short circuit in the power network S_{sc} .

The main elements in a system of traction electric supply are the transforming units, designed to convert the three-phase variable voltage of 6(10) kV to a constant pulsating voltage of 825 V. Each transforming unit, in turn, is composed of traction conversion transformers and rectifiers. At present, commonly used are conversion transformers the type of TSZP-1600/10, executed in line with a connection circuit of “star-triangle”, which are designed to work with the bridge six-pulse rectifiers (Table 1) [17].

Based on catalog data, given in Table 1, it is necessary to calculate the magnitudes of parameters for a conversion transformer in relative units. To build an imitational model of the transformer by using the software package SimPowerSystems, we applied formulae given in Table 2.

Table 1
Parameters for conversion transformer TSZP-1600/10

No. of entry	Parameter title	Value
1	Power S_n , kVA	1,515
2	Voltage of network winding U_{1n} , kV	10.500
3	Voltage of valve winding U_{2n} , kV	0.670
4	Losses of short circuit P_k , kW	16.5
5	Voltage of short circuit U_k , %	9.5
6	Idling current I_0 , %	0.4
7	Idling losses P_0 , kW	2.8

Table 2

Formulae to calculate parameters of a conversion transformer

Active resistance of primary R_1 and secondary R_2 windings of transformer	Inductance of primary L_1 and secondary L_2 windings of transformer	Active resistance of magnetization circle R_m	Inductance of magnetization circle L_m
$R_{1(p.u.)} = R_{2(p.u.)} = \frac{1}{2} \frac{P_k}{S_n}$	$L_{1(p.u.)} = L_{2(p.u.)} = \frac{1}{2} \frac{U_k}{100}$	$R_{m(p.u.)} = \frac{S_n}{P_0}$	$L_{m(p.u.)} \approx \frac{100}{I_0}$

When calculating the traction network at an underground rail system, it is important to consider resistances of power feeders and traction power transmission lines, as well as contact and running rails, in the form of active resistances and inductances.

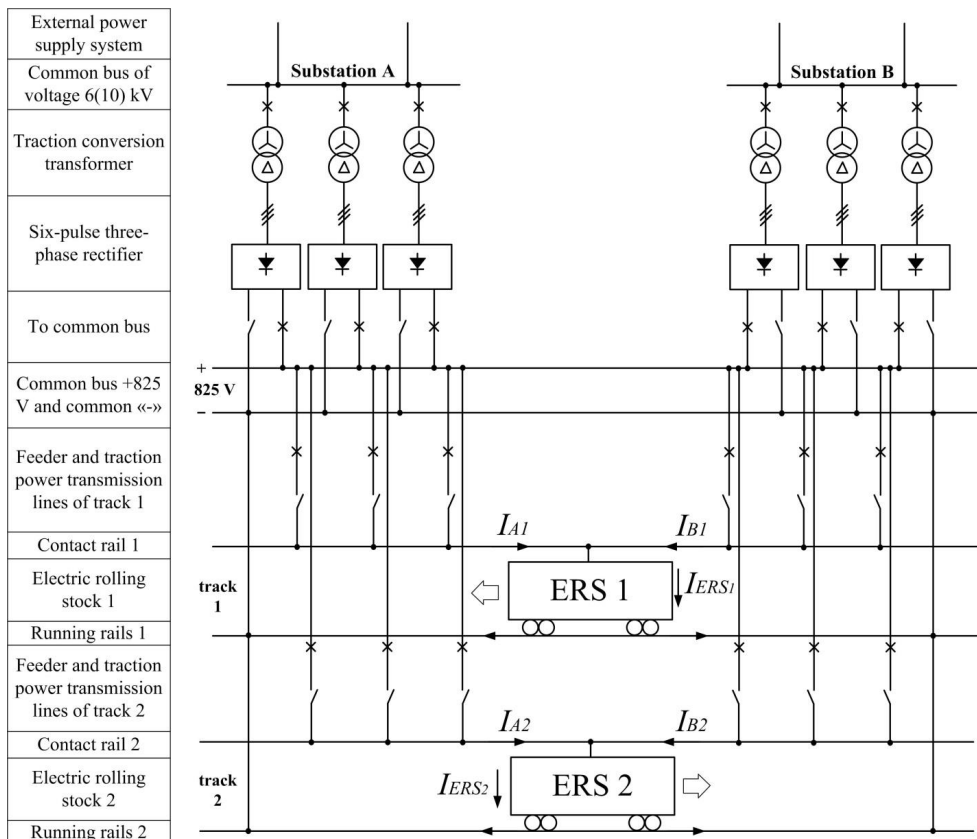

Fig. 2. Standard arrangement of the underground traction power system zone

Formulae to calculate active resistances and inductances for a traction network are given in Table 3, where r_{0f} (r_{0v}) is the resistance of each cable per 1 km, m_f (m_v) is the number of cables enabled in parallel, l_f (l_v) is the length of cables; X_{cab} is the inductive resistance of a cable wire per 1 km; r_c is the resistance of 1 km of a contact rail, l_c is the length of a contact rail; r_r is the resistance of 1 km of a rail thread; l_r is the length of the estimated section of running rails, m is the number of insulating joints, n is the number of rail threads for two tracks; P_c (P_r) is the perimeter of the conductor, μ_p is the relative permeability of rails, ρ_c (ρ_r) is the resistivity of a conductor's material, τ is a time constant.

Estimation parameters for a replacement circuit of the electricity supply system for the case r_{0f} (r_{0v})=0.074 Ohm/km, l_f (l_v)=0.150 km, m_f (m_v)=3, X_{cab} =0.158 Ohm/km, r_c =0.0189 Ohm/km, r_r =0.0205 Ohm/km, m =10, n =4, P_c (P_r)=0.5 (0.62), ρ_c (ρ_r)=0.12·10⁻⁶ (0.21·10⁻⁶), μ_p =250 are given in Table 4.

Fig. 3 shows an imitational model of the section in a traction network, developed in the programming environment Matlab/Simulink for the parameters given above. The voltage in the contact network, measured at a real object and modeled in the presence of a load in the form of electric rolling stock, is shown in Fig. 4.

Table 4

Parameters for a replacement circuit of the electricity supply system

R_f , Ohm	R_v , Ohm	L_f , Gn	L_v , Gn	R_c , Ohm	R_r , Ohm	L'_c , Gn	L'_r , Gn
0.0037	0.0042	0.001	0.001	0.0378	0.008	0.0017	0.0018

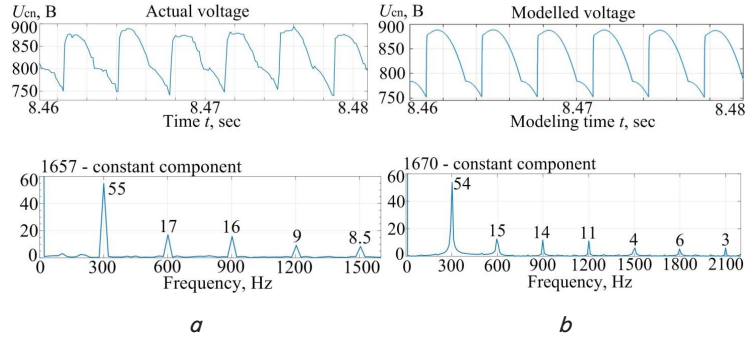

Fig. 4. Comparison of signals and spectral analysis of the contact network voltage: a – measured actually; b – modelled

The results of spectral analysis confirm an acceptable correspondence of the deviation in the magnitudes of the main spectral components in the signal from the modeled voltage in a contact network at the level of 10 % in comparison with the actually measured voltage.

Table 3

Formulae to calculate active resistances and inductances of traction network

Active resistance of feeder R_f and traction power transmission line R_v , Ohms	Inductance of cables of feeder L_f and traction power transmission line L_v	Active resistance of contact rail R_c	Active resistance of running rails R_r	Internal inductances of contact L'_c and running L'_r rails
$R_{f(v)} = \frac{r_{0f(v)} \cdot l_{f(v)}}{m_{f(v)}}$	$L_{f(v)} = \frac{X_{cab}}{2 \cdot \pi \cdot f} \cdot l_{f(v)}$	$R_c = r_c l_c$	$R_r = \frac{r_r (l_r + 0.036m)}{n}$	$L'_{c(r)} = \frac{0.48}{P_{c(r)}} \cdot \sqrt{\mu_p \cdot \rho_{c(r)}} \cdot \sqrt{\tau}$

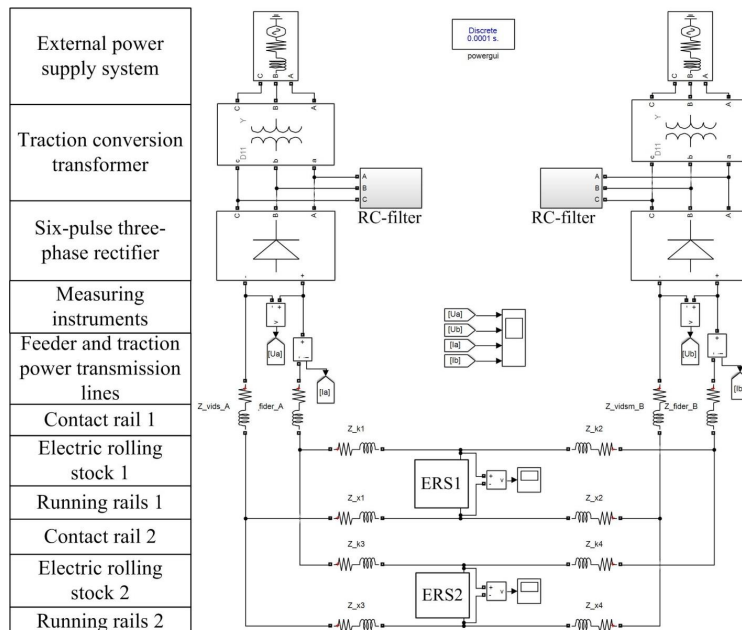

Fig. 3. An imitational model of the system of underground traction electric supply in the programming environment Matlab/Simulink

5. Traction electric drive of underground rail cars with a vector system of control over the induction electric drive

Typically, modern underground rail system cars with a traction induction electric drive (TIED) are driven using four three-phase traction induction electric motors (Fig. 5). Electric motors are mounted on two bogies; the torque is transmitted to each wheelset through a toothed coupling and a single-stage reducer.

A set of modern traction electric drive includes [18]:

- current collectors *XHT1-4*, mounted on bogies at each side;
- protective switching high-voltage equipment: fuses *FU1-FU2*, main disconnector *S* and the high-speed switch *HSCB*;
- a circle of preliminary charge of condensers *K11-K12-R1, K21-K22-R2*;
- input smoothing throttles *L1, L2* and capacitors *C1, C2* of the input filter to filter the peak surges in voltage *du/dt* and current *di/dt* from input circuits;
- four traction inverters *FT1-FT4* in two undercar units that are designed for an independent drive of induction motors at each bogie;
- braking resistors *R_{Br1}-R_{Br2}*, designed to dissipate the energy generated during train deceleration;
- traction motors *M1-M4* with sensors for rotation speed and temperature;
- grounding devices *ZUM1-4*.

To control rotation speed of induction motors, a traction inverter of the drive employs an indirect vector control with the orientation along the rotor flux-coupling and the space-vector modulation of the inverter switches (Fig. 6). Such a control technique makes it possible to independently control the torque and flux-coupling of the engine in order to obtain the required dynamic properties. To execute the basic principles of vector control, a rotational electromagnetic torque of the traction induction motor is controlled, which forms by influencing the amplitudes of base vectors (vectors of stator current *i_{qs}* and rotor flux linkage *ψ_r*) [19]:

$$M_{em} = 1.5 p \frac{L_m}{L_r} (\psi_r i_{qs}), \quad (2)$$

where *L_m* is the mutual inductance of magnetization circle, *L_r* is the inductance of the rotor, *ψ_r* is the rotor flux linkage, *i_{qs}* is the stator current along the *q* coordinate.

Computing the three measured instantaneous values for phase currents *i_a*, *i_b* and *i_c* is rather cumbersome and mathematically redundant, which is why they are reduced to two, *i_α-i_β*, using a Clark transform. Transforming phase currents *i_α-i_β* from a sinusoidal form to the two-axial coordinate system *i_d, i_q* through a Park-Gorev transform would subsequently enable a much more convenient and faster processing of constant magnitudes. A space-vector modulation is a complicated method of PWM, which provides benefits

in application in comparison with a classic sinusoidal PWM with a “current corridor”. This type of modulation generates a 15 % higher utilization of voltage in a DC bus and reduces the percentage of total harmonic distortion factor THD %.

Setting the parameters for the electric drive requires the calculation of parameters for the induction motor, the clarification of parameters for regulators, and the determination of parameters for a DC bus.

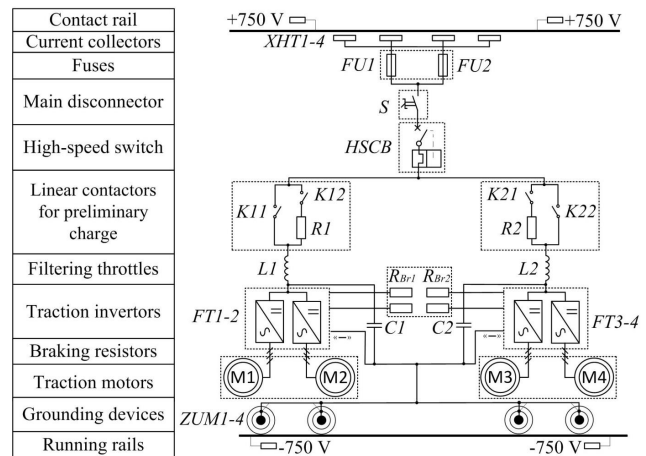

Fig. 5. Diagram of power circles of the underground rail car with TIED

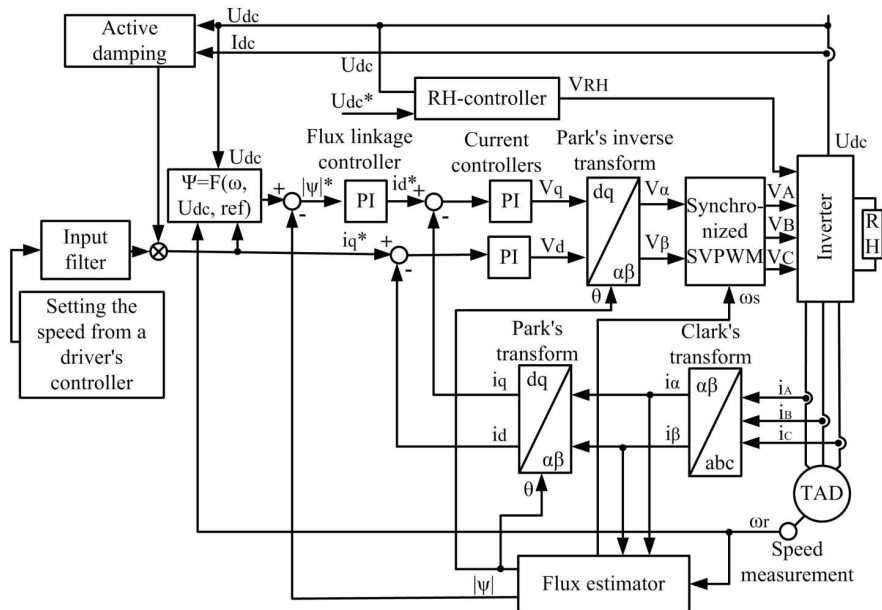

Fig. 6. Structural diagram of the control system of TIED traction inverter

The model employs parameters for the traction induction motor with a power 180 kW, the type of STDa 280-4B-UK, made by EMIT Cantoni Motors (Poland), for underground cars of series 81-7036/7037, whose specifications are given in Table 5 [20].

Calculation of parameters for constructing an imitative model of the induction motor implies determining the active and inductive resistances of stator *R_s* and rotor *R_r*, the inductance of scattering of the stator and rotor *L'_s* and *L'_r*, as well as the mutual inductance of magnetization circle *L_m* (Table 6). In a given notation, mechanical losses are determined from *P_{mec}*=(0.01 0.05) *P_n*, *s_n* and *s_{cr}* is the nominal

and critical sliding, $C_p = 1 + \frac{L_{sp}}{L_m}$ is the estimation coefficient.

When building a system of vector control over the traction electric drive, we applied proportional-integral controllers of flux linkage, speed, and current in the induction motor. Proportional K_{p_i} and integral K_{i_i} coefficients of controllers for $i \in \{1, \dots, 3\}$ can be determined using method [21] or [22].

Table 5

Specifications of traction induction motor

No. of entry	Parameter title	Value
1	Rated power P_n , kW	180
2	Rated linear power voltage U_n , V	500 (V)
3	Rated frequency f_n , Hz	63
4	Rated current I_n , A	257
5	Number of pole pairs Z_p	2
6	Rotation frequency n , rpm	1,854
7	Maximal rotation speed n_{max} , rpm	4,018
8	Power factor $\cos\phi$	0.86
9	Efficiency η	0.94
10	Rated torque M_n , Nm	927
11	Multiplicity of starting current K_i	5.0
12	Multiplicity of starting torque K_p	0.7
13	Multiplicity of critical torque K_m	2.2
14	Rotor moment of inertia J , kgm ²	1.75
15	Mass of motor m , kg	640

The obtained magnitudes of parameters for the replacement circuit of the traction electric drive are given in Table 7.

The developed imitational model of a single inverter with the induction motor and a vector control system is shown in Fig. 7. Units of elements in the vector control

system are designated as follows: 1 – speed setting; 2 – measured speed of rotor rotation; 3 – speed controller; 4 – calculation of flux linkage; 5 – flux linkage controller; 6 – calculation of θ ; 7 – Clarke’s and Park’s transforms; 8 – calculation of i_d ; 9 – calculation of i_q ; 10 – controllers of currents i_d and i_q ; 11 – inverse Park’s transform and decomposition of voltage U_{abc} into U_{ab} + angle; 12 – sector selector; 13 – measured voltage of the intermediate link; 14 – generator of the reference triangular voltage; 15 – sub-system of modulation; 16 – logic of switch’s; 17 – pulses to control switches; 18 – magnetization.

Table 7

Parameters for a replacement circuit of the traction electric drive

R_s , Ohm	R_r , Ohm	L'_s , Gn	L'_r , Gn	L_m , Gn	L_d , Gn	C_f , F	R_{Br} , Ohm
0.0237	0.0215	0.000369	0.000334	0.00855	0.003	0.009	1.25

An imitational model of mechanical part of the traction electric drive might be more or less detailed depending on the examined processes.

Fig. 8 shows a structural diagram of the unit to calculate the speed of an underground car where a multi-mass mechanical part of the electric drive is reduced to a single-mass part. Magnitude of the implemented traction effort is calculated taking into consideration a variable value for the coefficient of adhesion between a wheel and a rail ψ_0 .

Formulae to calculate a mechanical part of the traction electric drive are given in Table 8, where K_{gr} is the gearbox ratio, J is the reduced moment of inertia of rotational masses I and II of wheelsets, and, respectively, D_1 (D_2) are the wheels diameters, P_1 (P_2) is the weight per axle, k_1 (k_2) is the coefficient of adhesion between a wheel and a rail in relative units (Fig. 8), S_e is the equivalent surface of the train, m_c is the mass of the car with passengers, n_c is the number of cars in a train, F_y is the resultant forces of traction, motion and braking resistance, applied to the center of gravity of the train, m_{tr} is the physical weight of the train.

Table 6

Formulae to calculate parameters for traction induction motor

No. of entry	Parameter	Calculation formula
1	Reduced active rotor resistance R_r , Ohm	$R_r = \frac{1}{3} \cdot \frac{P_n + P_{mec}}{I_n^2} \cdot \frac{1 - s_n}{s_{cr}}$
2	Active stator resistance R_s , Ohm	$R_s = \frac{U_f \cdot \cos\phi \cdot (1 - \eta)}{I_n} - C_p^2 \cdot R_r - \frac{P_{mec}}{3 \cdot I_n^2}$
3	Reduced stator L'_s scattering inductance, Gn	$L'_s = \frac{U_n}{4 \cdot \pi \cdot f_n \cdot (1 + C_p^2) \cdot K_i \cdot I_n}$
4	Stator inductance L_s , Gn	$L_s = \frac{U_f}{2 \cdot \pi \cdot f_n \cdot I_n \cdot \sqrt{1 - \cos^2(\phi)}} - \frac{2 \cdot \pi \cdot f_n \cdot M_{max} \cdot s_n}{3 \cdot Z_p \cdot U_f \cdot s_{cr}}$
5	Mutual inductance L_m , Gn	$L_m = L - L'_s$

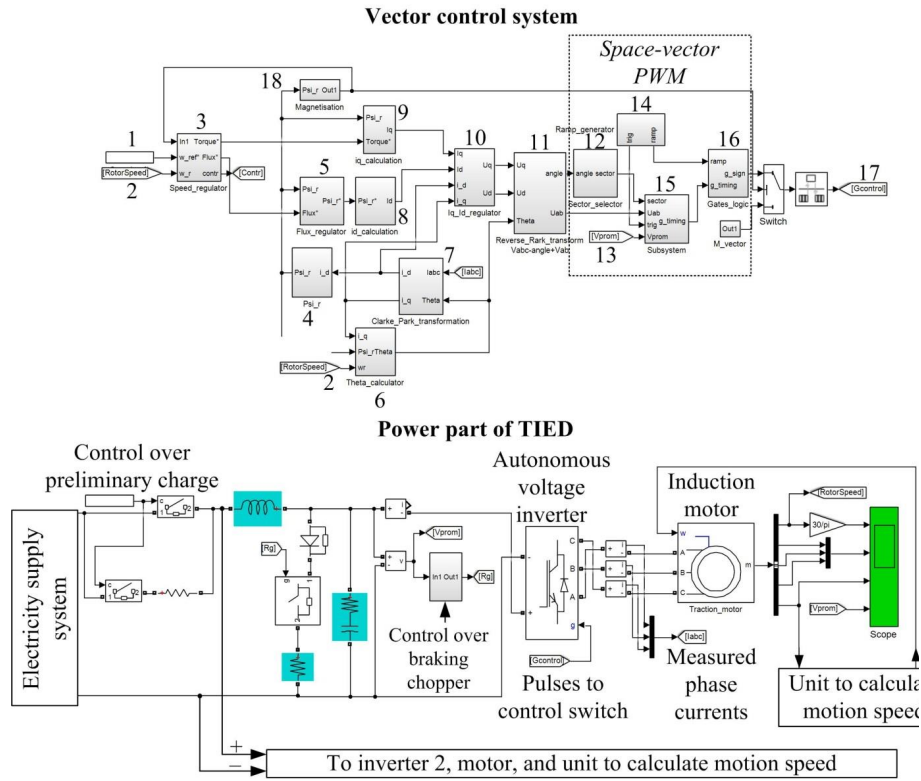

Fig. 7. An imitational model of TIED for a single-drive inverter of an underground car in the programming environment Matlab/Simulink

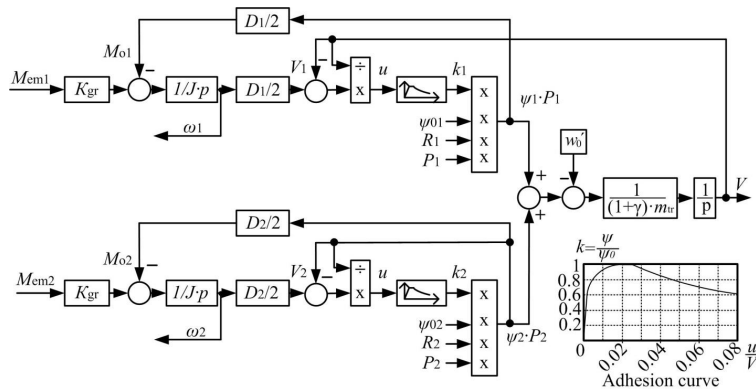

Fig. 8. Structural diagram of mechanical part of a bogie (single-mass)

Table 8

Formulae to calculate a mechanical part of the traction electric drive

No.	Parameter	Formula
1	Wheelset torque M_{ws} , N·m	$M_{ws1} = M_{em1} \cdot K_{gr}$
2	Wheelset rotation frequency ω_1 , rpm	$\frac{d\omega_1}{dt} = \frac{M_{ws1} - M_1}{J}$
3	Resistance momentum M_{o1} , N·m	$M_{o1} = \psi_1 \cdot P_1 \cdot D_1 / 2$
4	Wheelset linear velocity V_1 , m/s	$V_1 = D_1 \cdot \omega_1 / 2$
5	Slipping rate of wheels in the longitudinal direction u , %	$u = \frac{V_1 - V}{V} \cdot 100\%$
6	Wheelset's wheels traction effort F_{k1} , Nm	$F_{k1} = P_1 \cdot \psi_{01} \cdot k_1$
7	Main specific resistance to the underground car's motion at speed V under current	$\omega'_0 = 1, 1 + \frac{0,0092 S_e V^2}{m_c n_c}$
8	Train motion equation	$m_y (1 + \gamma) \frac{dV}{dt} = F$

An imitational model with the reduced mechanical part enables the qualitative and quantitative analysis of the course of dynamic processes in TIED when adhesion conditions worsen.

Fig. 9 shows a model of the course of dynamic processes at worsened adhesion conditions and in the absence of special protection.

The results shown in Fig. 9 demonstrate that at a value for the torque of (15,000 Nm) and at a maximum value for the potential coefficient of adhesion of 0.25 the car's wheelsets work within a productive branch of the adhesion characteristic. Reducing the potential coefficient of adhesion (wet rails) gives rise to the process of slipping. In case of deterioration by 20 %, a control system gradually recovers the assigned value for torque; by 50 % – there starts an irreversible process.

The developed comprehensive imitational model of the system for supplying traction electricity to the underground rail that accounts for the operational modes of electric rolling stock with TIED makes it possible to evaluate the mutual influence of the system's elements. As an illustration, Fig. 10 shows results of imitational modeling of the process of recuperation implementation. When the first rolling stock (the one car), which travels along track I, decelerates, the released energy is fed to the rolling stock that moves along track II.

When setting the parameters for calculating an imitational model, we applied a trapezoid method at interpolation ode23t with a minimally required step of integration in order to ensure functioning of the vector system of control over drive $\Delta t = 1 \times 10^{-5}$.

To test the adequacy of simulation results, we give a fragment of the actual oscillogram from the operation of underground rolling stock cars with an induction electric drive (Fig. 11). The adequacy of the results obtained by simulation is confirmed by the time required to accelerate to a speed of 75 km/h (~20 seconds), by the current used (~1,200 A), and by voltage when braking (>900 V).

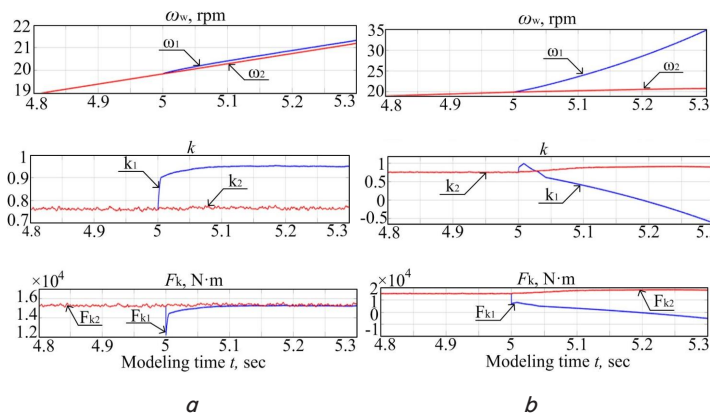

Fig. 9. The course of dynamic processes under worsened adhesion conditions at $t=5$ s and in the absence of special protection at decreasing ψ_0 : a – by 20 %; b – by 50 %

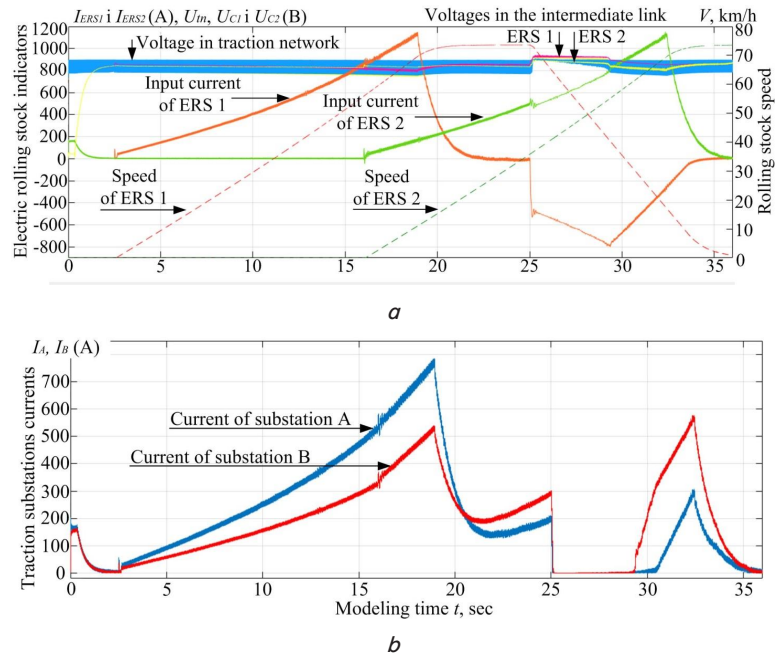

Fig. 10. Results of imitational modeling: a – indicators for operation of ERS 1 and 2; b – currents at the output of traction substations A and B

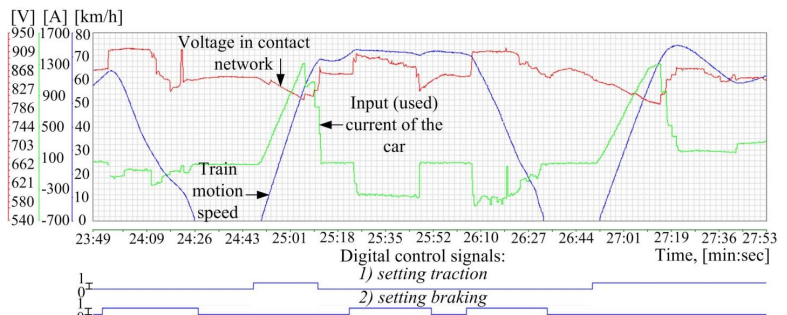

Fig. 11. A fragment of the actual oscillogram of the motion of train with TIED

6. Discussion of results of studying a comprehensive imitational model of the electric traction system

Regenerative braking is a rational technique to save electricity, reduce levels of pulsation of voltage and current, reduce a load on the traction network, shorten the time when rolling stock is exposed to reduced voltage, as well as ensure the uniformity of power consumption. The main condition for attaining the recuperative braking is that the electromotive force of electric machine should exceed the applied voltage $E > U$. In this case, the current and, therefore, electrical energy, would be directed from the traction machine to the network.

Fig. 10 shows that over a certain time (from second 25 to second 29) an electric train, which utilizes the recuperated energy, can do completely without the energy that comes from substations. The amount of usefully spent energy would certainly depend on the time at which one electric train decelerates and the speed at which another one moves.

One may also note that at work of the second electric train from the start and until reaching the steady

characteristic of the first electric train, the curves of current used by both electric trains exhibit an increase in the level of high-frequency pulsations. In other words, electric trains directly affect each other through the contact network of two tracks. It is obvious that these manifestations are compensated for both by the inductive resistances of the traction network and by the input *LC*-filters of the drive. However, the effects of frequencies in the spectrum of pulsations on the losses and quality of electric energy, reliability of under-station, tunnel, and car equipment, as well as the means of communication, require detailed studying.

In the oscillograms above, one can note an explicitly prevailing feature of the simulation – a possibility to obtain the instantaneous, rather than current, values for parameters, which makes it possible to more accurately assess the transient electromagnetic processes.

Note that most earlier studies typically analyzed processes in the systems of electric traction under assumption of independent individual components. Actual objects parameters have finite values while the power of load is comparable with a power source capacity. Underestimation of the parameters and properties of at least one of the subsystems leads to errors in the analysis of mechanical-energy transients. Therefore, the structure of electric traction should be considered as a complex system that has a limited number of elements, interrelated via certain connections, applying an integrated approach to its analysis.

By employing the developed imitational model, it is possible to carry out a comprehensive analysis of emerging transients, starting at the point when a traction substation is connected to power supply networks and finishing with the process of interaction between the wheels of rolling stock and rails. That would make it possible to solve existing tasks in need of solutions, to anticipate potential problems during simulation, as well as contribute to building control and diagnosis systems based on the model of the object.

In the course of modeling, we used generally accepted assumptions: the absence of internal phenomena in the equipment (saturation, losses in steel), simplification of non-linear characteristics of semiconductor devices (resistance of switches, instantaneous switching); we disregarded loading of rolling stock and the aerodynamic motion drag. The above might insignificantly limit the accuracy of analysis, such as emergency regimes.

Possible shortcomings of the study relate to that the characteristics of operation of both the traction network and rolling stock will depend on the profile of the track and the driving mode chosen by a train driver. It is possible to elimi-

nate this drawback by using specific route data on the profile and motion schedule.

This work could be further developed by addressing the addition and improvement of the subsystems elements, which would provide greater accuracy and specific targets to detailed studies. Promising among them is to supplement the developed model with subsystems of auxiliary electrical and mechanical equipment, as well as to improve it based on modern methods of control and diagnosis.

7. Conclusions

1. We have constructed an imitational model of the system for traction DC power supply with a two-way feed to two tracks, which makes it possible to assess currents and voltages in the contact network, as well as the processes of interaction between moving units. The proposed development procedure is based on the use of catalog data on the main elements in the system of traction electric supply and estimation expressions in the form that is convenient for engineering and scientific application.

2. We have built an imitational electromechanical model of the underground rolling stock car with a vector control system and a space-vector pulse-width modulation in the traction induction electric drive. The developed model adequately reproduces an example of modern rolling stock, which is implemented at underground rail systems, and enables qualitative and quantitative analysis in the course of dynamic processes in TIED.

3. We have verified the results of imitational modeling of transient processes in the operation of a power supply system, as well as rolling stock, for the compliance with an actual examined object, which makes it possible to argue about the adequacy of the performed calculations. Errors in modeling do not exceed 10 % for the spectrum of voltage in the electricity supply system and current used and the acceleration time of rolling stock.

4. We have tested the efficiency of application of the developed comprehensive imitational model for solving the set problems using an example of reproducing a process at which energy recuperates for trains at adjacent track. A considerable potential of energy from recuperative braking was established, which is over 25 % of the total volume of energy spent under a traction mode, and depends on the operating mode and operating conditions. Modeling data could be used in the process of designing energy-efficient onboard and stationary systems for the accumulation and conversion of energy.

References

1. Basov H. H., Yatsko S. I. Rozvytok elektrychnoho motorvahonnogo rukhomoho skladu. Ch. 2. Kharkiv: «Apeks+», 2005. 248 p.
2. Development of equipment for distribution devices power traction electric supply. Part I / Yatsko S., Karpenko N., Vashchenko Y., Panchenko V. // Collected scientific works of Ukrainian State University of Railway Transport. 2017. Issue 172. P. 37–48. doi: <https://doi.org/10.18664/1994-7852.172.2017.116689>
3. Analysis of optimal operating modes of the induction traction drives for establishing a control algorithm over a semiconductor transducer / Liubarskyi B., Petrenko A., Shaida V., Maslii A. // Eastern-European Journal of Enterprise Technologies. 2017. Vol. 4, Issue 8 (88). P. 65–72. doi: <https://doi.org/10.15587/1729-4061.2017.109179>
4. Optimization of thermal modes and cooling systems of the induction traction engines of trams / Liubarskyi B., Petrenko O., Iakunin D., Dubinina O. // Eastern-European Journal of Enterprise Technologies. 2017. Vol. 3, Issue 9 (87). P. 59–67. doi: <https://doi.org/10.15587/1729-4061.2017.102236>
5. Su S., Tang T., Wang Y. Evaluation of Strategies to Reducing Traction Energy Consumption of Metro Systems Using an Optimal Train Control Simulation Model // Energies. 2016. Vol. 9, Issue 2. P. 105. doi: <https://doi.org/10.3390/en9020105>

6. Sulym A. On the question of a reasonability of capacitive storages use in the metro // *Elektromekhanichni i enerhozberihaiuchi systemy*. 2015. Issue 1 (29). P. 94–100.
7. Accurate track modeling for fault current on DC railways based on MATLAB/Simulink / Yu L., He J. H., Hu J., Bo Z. Q., Li M. X., Yip T., Klimek A. // *IEEE PES General Meeting*. 2010. doi: <https://doi.org/10.1109/pes.2010.5590135>
8. Panchenko V. V. Dynamic properties of system «rectifier with buck converter – load» // *Eastern-European Journal of Enterprise Technologies*. 2013. Vol. 4, Issue 8 (64). P. 14–17. URL: <http://journals.uran.ua/eejet/article/view/16445/13927>
9. Sablin O. I. Study of the efficiency of the electric energy recovery process in the subway // *Eastern-European Journal of Enterprise Technologies*. 2014. Vol. 6, Issue 8 (72). P. 9–13. doi: <https://doi.org/10.15587/1729-4061.2014.30483>
10. Control of urban rail transit equipped with ground-based supercapacitor for energy saving and reduction of power peak demand / Gao Z., Fang J., Zhang Y., Jiang L., Sun D., Guo W. // *International Journal of Electrical Power & Energy Systems*. 2015. Vol. 67. P. 439–447. doi: <https://doi.org/10.1016/j.ijepes.2014.11.019>
11. Modeling and simulation of DC rail traction systems for energy saving / Tian Z., Hillmansen S., Roberts C., Weston P., Chen L., Zhao N. et. al. // *17th International IEEE Conference on Intelligent Transportation Systems (ITSC)*. 2014. doi: <https://doi.org/10.1109/itsc.2014.6958067>
12. Modeling and Simulation of Metro DC Traction System with Different Motor Driven Trains / Du F., He J. H., Yu L., Li M. X., Bo Z. Q., Klimek A. // *2010 Asia-Pacific Power and Energy Engineering Conference*. 2010. doi: <https://doi.org/10.1109/ap-peec.2010.5448372>
13. Model validation of the whole traction system of an automatic subway / Verhille J. N., Bouscayrol A., Barre P. J., Hautier J. P. // *2006 IEEE Vehicle Power and Propulsion Conference*. 2006. doi: <https://doi.org/10.1109/vppc.2006.364346>
14. The Metrô Rio case study / Ferrari A., Fantechi A., Magnani G., Grasso D., Tempestini M. // *Science of Computer Programming*. 2013. Vol. 78, Issue 7. P. 828–842. doi: <https://doi.org/10.1016/j.scico.2012.04.003>
15. Comparison of Different Models and Simulation Approaches for the Energetic Study of a Subway / Mayet C., Horrein L., Bouscayrol A., Delarue P., Verhille J.-N., Chattot E., Lemaire-Semail B. // *IEEE Transactions on Vehicular Technology*. 2014. Vol. 63, Issue 2. P. 556–565. doi: <https://doi.org/10.1109/tvt.2013.2280727>
16. Quality assessment of control over the traction valve-inductor drive of a hybrid diesel locomotive / Buriakovskiy S., Babaiev M., Liubarskiy B., Maslii A., Karpenko N., Pomazan D. et. al. // *Eastern-European Journal of Enterprise Technologies*. 2018. Vol. 1, Issue 2 (91). P. 68–75. doi: <https://doi.org/10.15587/1729-4061.2018.122422>
17. Dynamic Model and Causal Description of a Traction Power Substation Based on 6-Pulse Diode Rectifier / Mayet C., Delarue P., Bouscayrol A., Chattot E., Verhille J.-N. // *2014 IEEE Vehicle Power and Propulsion Conference (VPPC)*. 2014. doi: <https://doi.org/10.1109/vppc.2014.7007054>
18. 7036.000.000 RE. Vagony metropolitena modeley 81-7036 i 81-7037. Rukovodstvo po ekspluatácii. Kremenchug, 2016. 115 p.
19. Simulation of Field Oriented Control in Induction Motor Drive System / Zhao X., Liu H., Zhang J., Zhang H. // *TELKOMNIKA Indonesian Journal of Electrical Engineering*. 2013. Vol. 11, Issue 12. doi: <https://doi.org/10.11591/telkomnika.v11i12.3674>
20. METRO KIEV. General specification for electric equipment. Warszawa, 2009. 51 p.
21. Retune the Drive Parameters. URL: <https://www.mathworks.com/help/physmod/sps/powersys/ug/advanced-users-re-tune-the-drive-parameters.html>
22. Adaptivnoe upravlenie v diskretnykh sistemah vysokogo poryadka s zapazdyvaniem. Chast' 3. Sintez adaptivnogo chastotno-impul'snogo PI-regulyatora s optimizaciey parametrov nastroyki na osnove kriteriya garantirovannoy stepeni ustoychivosti / Sytnik B. T., Yac'ko S. I., Bryksin V. A., Mihaylenko V. S., Uskov Yu. P. // *Collected scientific works of Ukrainian State University of Railway Transport*. 2012. Issue 128. P. 182–192.