I.A. Moskalyk¹, O.M. Manyk²



I.A. Moskalyk

¹Institute of Thermoelectricity of the NAS and MES
Ukraine, 1, Nauky Str., Chernivtsi, 58029, Ukraine;

²Yu. Fedkovich Chernivtsi National University,
2, Kotsyubinsky Str., Chernivtsi, 58012, Ukraine



O.M. Manyk

**ON THE USE OF THERMOELECTRIC
COOLING IN CRYODESTRUCTION
PRACTICE**

In this paper, the current state of using cryodestruction in medical practice, cryodestruction mechanism and temperature modes are analyzed. The disadvantages of liquid nitrogen-based devices and perspectives for using thermoelectricity in cryodestruction practice are defined.

Key words: cryodestruction, liquid nitrogen cooling, thermoelectric cooling.

Introduction

General characterization of the problem. It is a matter of common knowledge in medical practice that temperature action is an important factor in the therapy of many human diseases [1]. One of promising lines is cryodestruction, i.e. a combination of surgical therapy methods based on local freezing of human body tissues. To perform cryodestruction, it is necessary to cool certain area of human body to temperature $-50\text{ }^{\circ}\text{C}$. Today such cooling is implemented by means of special cryoinstruments with the application of nitrogen [1, 3-7]. However, the use of nitrogen has a number of disadvantages, namely nitrogen does not assure cooling with the required accuracy of temperature control, and there are risks of overcooling with negative consequences. Moreover, liquid nitrogen is a rather dangerous substance and must be used with proper care, while liquid nitrogen delivery is not always accessible, narrowing down possible application of such method. This opens up the prospects of using thermoelectric cooling for cryodestruction that can implement cooling to temperature $(0 \div -80)^{\circ}\text{C}$. Thermoelectric devices of medical application can assign precisely the necessary temperature of working instrument, the time of thermal action on the respective area of human body and assure cyclic change of cooling and heating [2].

Therefore, *the purpose of this paper* is analysis of the present state of using cryodestruction and determination of promising lines of using thermoelectricity in cryodestruction practice.

Cryodestruction mechanism

The problem of cold action on the biological tissue should be considered in two different temperature ranges, namely above and below freezing temperature of tissue fluid [8-13].

In the former case it is the matter of physiological response of biological tissue to ambient temperature reduction, and in the latter case we are referring to the damage of cellular structures due to tissue fluid expansion on freezing (formation of ice crystals). In different types of cells, with a decrease in temperature, synthesis of the so-called cold shock proteins is sharply accelerated (several factors of ten), assuring adaptation of cells to new temperature conditions. During this adaptation,

many cellular processes that are practically stopped by cold shock are restored, and a cell starts normal functioning under new conditions.

Below freezing point, the process of freezing intercellular fluid starts, then intracellular frosting occurs with formation of ice crystals moving around crystallization centres. Cryonecrosis arises gradually, whereby the cells and intracellular membranes are damaged by ice crystals ("cut" in a submicroscopic fashion). Blood circulation, ingress of oxygen and nutritional substances, tissue respiration and all biochemical processes during freezing cease completely. As a result, cells in which all vital processes were paralyzed for a long term are perished. At an instant when ice crystals are formed in the tissues, the osmotic pressure in the cells is drastically increased, since extracellular fluid freezes faster and salt cations are directed through membranes inside the cells. Such osmotic shock cannot be survived by biological cells.

Cryodestruction is widely used for the destruction of pathogenic tissues, i.e. tumors. During the first hours after cryosurgical operation, a direct edema of the tumor and surrounding tissue occurs. The edema is of primary importance in assuring hemostatic characteristics of cryodestruction. In so doing, the surrounding tissue is compressed by the edema, as a result of which blood circulation of damaged tissue area is restricted. Therefore, the tumor is separated, metabolism is stopped and intracellular pressure is increased. That is why cryodestruction is a disseminating method for the destruction of malignant tumors [13-18].

Use of cryodestruction in medical practice

Cryodestruction is qualified as the most natural and physiological method for producing necrosis, i.e. destruction of biological tissue [5]. With cryodestruction, in the process of surgical operation a pathogenic tissue is not removed, however, destructed due to cryothermal effect, the tissue will remain on its place for a rather long time. In the destructed pathological tissue, cryonecrosis is gradually formed which is partially resolved and renewed by healthy tissues, and on the surface of human body it is rejected.

At the present time, cooling agent most commonly used for cryodestruction in medical practice is liquid nitrogen. It is a colorless and odorless liquid of which boiling temperature under atmospheric pressure is $-195.81\text{ }^{\circ}\text{C}$ [5, 6].

A variety of instruments, cryogenic plants and cryosurgical systems have been created that run on liquid nitrogen, nitrogen oxide and carbon dioxide. The overwhelming majority of them is cumbersome and requires periodic replacement of containers. Such instruments are characterized by the operating temperature range, time to operating mode, accuracy of temperature control, overall dimensions and continuous work time. Special methods for using such instruments have been developed that allow treatment a wide range of diseases in various areas of medicine (Table 1).

Cryodestruction temperature modes

Temperature reduction on the boundary of pathologic and healthy tissue should take place in the limits minimum required for cryogenic destruction of the entire abnormal focus [5, 19]. The values of temperature for cryogenic destruction of various kinds of tissues vary in the limits:

- $0\text{ }^{\circ}\text{C}$ – brain;
- $-20\text{ }^{\circ}\text{C}$ – $-30\text{ }^{\circ}\text{C}$ – skin;
- $-50\text{ }^{\circ}\text{C}$ – biological tissue.

Table 1

Areas of cryodestruction application in medical practice

Area of medicine	Domain of usage
Abdominal surgery (abdominal oncology)	<ul style="list-style-type: none"> • removal of malignant tumors and metastases in liver; • removal of benign and vascular tumors (cysts, adenomas, hemangiomas) in liver; • treatment of parasitic diseases; • treatment of chronic diffuse lesions of liver (hepatitis, cirrhosis); • treatment of acute pseudotumor and chronic pancreatitis; • removal of malignant, mostly unresectable tumors, benign tumors and kidney cysts; • removal of oncopathologies of lung tissues (squamous cell carcinoma of moderate and low differentiation degree, adenocarcinoma of different maturity degree, large cell carcinoma, small cell carcinoma); • lymph node cryodissection and lymph cryoectomy as the mandatory procedure at surgery of neoplasms of internal organs: mammary gland, stomach, liver, pancreatic gland, kidneys, rectum.
Gynecology	<ul style="list-style-type: none"> • cryodestruction of uterine cervix polyps and sharp-pointed condylomata; • cryodeneration of sacral-uterine ligaments; • laparoscopic ablation of uterine nerves; • therapy of menstrual disorders and premenstrual syndrome.
Dermatology	<ul style="list-style-type: none"> • removal of warts, skin formations, fibromas, keratoses, hemangiomas, condilomatas, koloids, basaliomas, sarcomas, solar and senile lentigo, birthmarks; • destruction of undesirable masses, including virus warts, dermafibroma, condyloma, molluscum contagiosum, actinic and seborrheic ketatoses; • therapy of seborrhea and acne, psoriasis, eczema, dermatitis, acneiform rash, as well as treatment of other skin defects.
General surgery	<ul style="list-style-type: none"> • bloodless painless removal of pathologically changed tissues, infiltrations and neoplasms using cryodestruction.
Burn surgery (combustiology)	<ul style="list-style-type: none"> • destruction of tissues at burns; • therapy of burn shock and pathologic states.
Oncology	<ul style="list-style-type: none"> • cryodestruction of malignant and benign neoplasms of head and neck; • cryodestruction of malignant, benign and tumor-like lesions of bones; • cryodestruction of mammary tumors; • destruction of skin tumors.
Otolaryngology	<ul style="list-style-type: none"> • cryosurgery of chronic rhinitis; • cryosurgery of chronic tonsillitis; • cryotherapy of atheromas at suppuration stage; • cryotherapy of papillomas of external ear canal; • cryotherapy of snoring patients with elongated and thickened uvula; • cryotherapy of auricle keloid scars; • cryotherapy of chronic pharyngitis; • cryosurgical therapy of patients with hemangiomas.
Ophthalmology	<ul style="list-style-type: none"> • removal of basalioma on the internal surface of eyelid; • removal of malignant epithelial tumors of lids of T1-T4 stages, basaliomas, papillomas, conjunctive melanomas.
Phlebology	<ul style="list-style-type: none"> • removal of varisose veins of lower limbs ("cryostripping").
Neurosurgery	<ul style="list-style-type: none"> • destructions of deeply seated brain structures, pathways in the central nervous system; • local cooling of certain cerebral cortex areas at epilepsy.

Temperature reduction of biological tissue to $(-5 \div -10)^\circ\text{C}$ starts the process of crystal formation in the extracellular space, and temperature reduction to $(-15 \div -20)^\circ\text{C}$ and lower starts the process of ice crystals formation inside the cells, leading to death of biological tissue. It is noteworthy that the mass of ice formed occupies the volume 10 % greater than the volume of liquid the ice crystals are formed of [18, 19, 21]. Maximum damaging effect is achieved on cooling biological tissue to -50°C , and further temperature reduction does not increase the lethality of cells [5, 6, 18-28].

The intensity of cells destruction in freezing focus depends not only on the minimum temperature in the focus, but also on the biological tissue cooling rate. A relatively fast freezing $(40 - 50)^\circ\text{C}/\text{min}$ is optimal. The efficiency of cell cryodestruction is high, if it has no time to displace through membranes the intracellular fluid in the process of tissue cooling prior to freezing [18, 19, 22].

A slower freezing $(3 - 5)^\circ\text{C}/\text{min}$ is not reasonable, since in this case no processes of intracellular ice formation take place. Also, it is not expedient to use superfast freezing (over $100^\circ\text{C}/\text{min}$), since in this case amorphous ice is formed that does not damage the structure of biological tissue [18].

Cryodestruction reliability is largely dependent not only on cooling rate, but also on further heating rate, as long as the damaging action of low temperatures arises both in the process cells transformation to ice crystals, and during their thawing to normal temperature. Destruction of cells at thawing is no less intensive than at freezing, since thawing causes ice recrystallization, intensifying the destructive effect on living cells. With a slow heating, interacellular ice crystals go on growing for some time and damaging the intracellular formations. Thawing at a rate of $(10 - 12)^\circ\text{C}/\text{min}$ assures the most reliable destruction of cells [18-22].

Multiple freezing-thawing allows decreasing the temperature which is lethal for pathological tissue, finding a peculiar kind of compromise between a desire to freeze the neoplastic medium as much as possible and the necessity to preserve healthy surrounding tissues [18-28].

Nitrogen cooling and its disadvantages

Unfortunately, use of liquid nitrogen-based devices does not assure cooling with the necessary accuracy of temperature control. The highest precision of such devices is $\pm(5 - 10)^\circ\text{C}$. Moreover, liquid nitrogen is a substance dangerous enough and one must be careful using it. There are risks of overcooling with negative consequences. Also, storage and transportation of liquid nitrogen is problematic, which narrows down potentialities of using liquid nitrogen cooling method.

Thermoelectricity applicability for cryodestruction. Expected advantages

Investigations performed [5-7, 18-28] have confirmed the fact that to achieve the necessary curative effect at low temperatures, there is no need to use very low temperatures to the level of $(-150 \div -200)^\circ\text{C}$, typical of liquid nitrogen. One can use much more moderate temperatures about $(0 \div -50)^\circ\text{C}$, which opens up the prospects of using thermoelectric cooling down to temperature $(0 \div -80)^\circ\text{C}$.

It should be noted that destruction takes place not only on cooling, but also on heating of cooled tissue, which is convenient to be realized by thermoelectric cooling devices via current reversal through them. It creates potential advantage of thermoelectric devices over the nitrogen ones. Destruction efficiency increases essentially during cyclic cooling and heating which is also easily realized by thermoelectric devices.

Existing cryodestruction devices that employ thermoelectric cooling

Recent years have seen rather active use of thermoelectricity in medicine, in particular, in cryodestruction. A variety of thermoelectric medical devices has been developed that include thermoelectric devices and cryoextractors for cooling biological tissue, destruction of malignant tumors, that are used in various cryosurgical operations in ophthalmology, gynecology, urology, otolaryngology, etc.

To reduce blood loss and pain syndrome during surgical operations, thermoelectrically cooled surgical instruments shaped as lancets are used [29-32] (Fig. 1).

During recent years, in the Institute of Thermoelectricity of the National Academy of Sciences and Ministry of Education and Science of Ukraine research on the use of thermoelectric cooling in medicine has been pursued [33]. Samples of medical equipment for cryodestruction, such as thermoelectric cryoextractor (Fig. 2) [34], thermoelectric hypotherm for oncology (Fig. 3) [35, 36] have been created. Wide application has been found by thermoelectric devices for the destruction of soft tissues (cryoprobes and cryoextractors) (Fig. 4) intended for therapy of oncologic diseases, removal of malignant neoplasms and arrest of propagation of metastases [37-43].

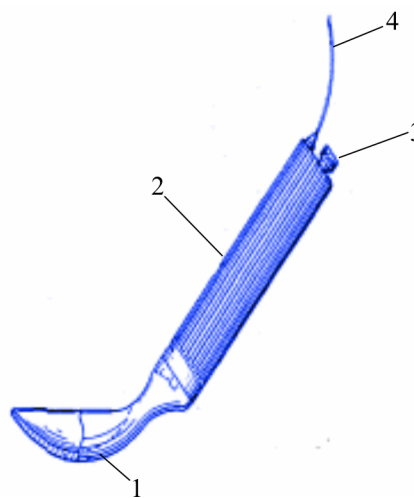

Fig. 1. Cold lancet. 1 – thermocouple unit; 2 – case; 3 – coolant container; 4 – electric cable.



Fig. 2. Thermoelectric cryoextractor.



Fig. 3. Thermoelectric hypotherm for oncology.

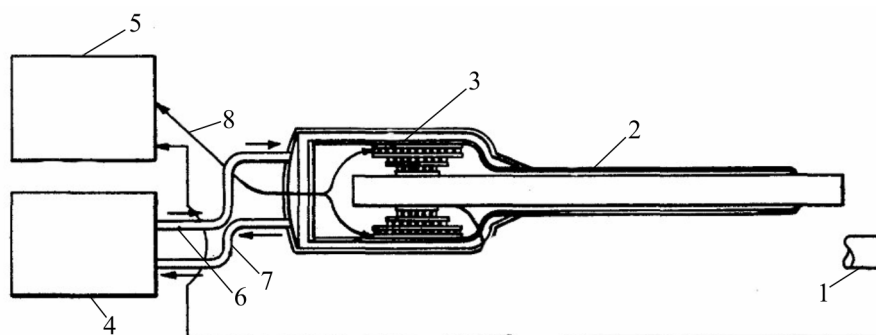

Fig. 4. Thermoelectric cryoprobe. 1 – disposable tip; 2 – heat pipe; 3 – thermoelectric modules; 4 – heat exchanger; 5 – control unit; 6, 7 – liquid coolant circulating tubes; 8 – control unit connection to thermoelectric modules.

There is also a good outlook for using cooling thermoelectric devices in dermatology and cosmetology. Such devices allow treatment of skin diseases and cryodestruction for the purpose of removing papillomas, condylomata, warts, hemangiomas, pigmental and vascular nevi, hypertrophic scars. When used in cosmetology, such devices offer the advantage of a good cosmetic effect, since their application leaves no scars, unlike surgical intervention [44-49].

Conclusions

1. It is established that liquid nitrogen is in most common use for cryodestruction. For implementation of cryodestruction about 40 such devices have been created.
2. From the practice of using cryodestruction it is found that the temperature of $-50\text{ }^{\circ}\text{C}$ is optimal for the destruction of biological tissue. In so doing, cooling rate must be in the range of $-(40 - 50)\text{ }^{\circ}\text{C}/\text{min}$. Destruction efficiency increases with cyclic cooling and heating.
3. For the implementation of optimal cryodestruction conditions thermoelectric cooling offers a number of advantages over nitrogen cooling. The existing thermoelectric devices for cryodestruction confirm their efficient use in medicine.

References

1. E.A. Kolenko, *Thermoelectric Cooling Devices*, 2nd ed. (Leningrad: Nauka, 1967), 283 p.
2. L.I. Anatyshuk, *Thermoelements and Thermoelectric Devices: Handbook* (Kyiv: Naukova Dumka, 1979), 768 p.
3. V. Denkov, *On the Edge of Life*, Transl. from Bulgarian by I.M. Saburova (Moscow: Znaniye, 1988), 192 p.
4. S. Maruyama, K. Nakagawa, and H. Takeda, The Flexible Cryoprobe Using Peltier Effect for Heat Transfer Control, *Journal of Biomechanical Science and Engineering* **3** (2), 138 – 150 (2008).
5. V.I. Kochenov, *Cryosurgical Preventive Oncology* (Nizhniy Novgorod, 2000), 56 p.
6. V.I. Kochenov, *Cryological Preventive Oncology: Concise Study Guide for Doctors and Students*, 2nd revised ed. (Nizhniy Novgorod, 2003), 92p.
7. V.I. Kochenov, Adhesive Effect in Cryosurgery, *International Abstract Journal* **8**, IV (1982).
8. S.A. Vasilyev, S.B. Pesnya-Prasolov, Use of Cryosurgical Method in Neurosurgery, *Neurosurgery* **4**, 63 – 70 (2009).
9. A.N. Zinkin, N.G. Zingilevskaya, and B.B. Muselyan, *Cryotherapy in Otholaryngology*

- (Guidelines) (Krasnodar, 1997), p. 16.
10. V.V. Shafranov, E.N. Borkhunova, M.A. Kostylev, D.I. Tsyganov, A.M. Torba, A.V. Taganov, L.P. Mezhov, Z.V. Kalmykova, Mechanism of Destruction of Biological Tissues at Local Cryodestruction, *Herald of the Russian Academy of Natural Sciences* **1**, 68 – 77 (2012).
 11. B.I. Kalperovich, T.B. Komkova, N.V. Merzlikin, et al., *Fundamentals of Liver and Pancreatic Gland Cryosurgery* (Tomsk: Pechatnaya Manufactura Publ., 2006), 232 p.
 12. S.A. Shalimov, et al. Cryosurgical Methods for Treatment of Inoperable Tumors of Abdominal Cavity, *Zdorovye Ukrainy* (newspaper), **74** (2003).
 13. E.I. Kandel, *Cryosurgery* (Moscow: Medicine, 1974), p. 303.
 14. K.C. Xu, Nikolai Korpar, and L.Z. Niu, *Modern Cryosurgery for Cancer* (World Scientific Publisher, 2012).
 15. V.V. Budrik, *Physical Fundamentals of Cryomethods in Medicine, Training Manual*, Transl. from Russian (2010), 140 p.
 16. S.M. Cooper, The History of Cryosurgery, *J. R. Soc. Med.* **94**, 196 – 201 (2001).
 17. D.K. Whittaker, Mechanisms of Tissue Destruction Following Cryosurgery, *Annals of the Royal College of Surgeons of England* **66**, 313 – 318 (1984).
 18. W. Yiu, M.T. Basco, J.E. Aruny, and B.E. Sumpio, Cryosurgery: A review, *Int. J. Angiol.* **16** (1), 1 – 6 (2007).
 19. T.A. Ismailov, Use of Semiconductor Thermoelectric Modules for Local Effect on Individual Parts of Human Organism, *Interacademic Collection of Articles* (Makhachkala: Dagestan State Medical Institute, 1991), p. 8 – 12.
 20. A.I. Paches, V.V. Shental, P.T. Ptukha, et al., *Cryogenic Method for Treatment of Head and Neck Tumors* (Moscow, 1978), p. 168.
 21. V.Yu. Shakhov, On the Most Rational Methods for Cryodestruction of Malignant Neoplasms, *Voprosy Onkologii* **9**, 31 – 37 (1983).
 22. V.I. Kochenov, Yu.V. Korolev, Simplest Cryoinstruments for Clinical Practice of Cryologist, *Medical Cryology*, Issue 4 (Nizhniy Novgorod, 2003), p. 157 – 160.
 23. I.I. Potapov, et al. *Cryosurgery in Otolaryngology* (Moscow: 1975).
 24. V.D. Dragomiretskii, Cryosurgicaql Methods for Treatment of Ear, Nose and Throat Diseases, *Practical Cryomedicine*, Ed. by V.I. Grischenko and B.P. Sandomirskii (Kyiv: Zdorovye, 1987), p. 91 – 118.
 25. N.I. Nikolayev, V.I. Kochenov, S.N. Tsybusov, et al., Use of Regeneration Effects of Cryotreatment in Surgery and Plastics of Drum Membrane, *Medical Cryology*, Issue 4 (Nizhniy Novgorod, 2003), p. 176 – 188.
 26. B.I. Alperovich, L.M. Paramonova, and N.V. Merzlikin, *Cryosurgery of Liver and Pancreatic Gland* (Tomsk, 1985).
 27. B.I. Verkin, V.I. Grischenko, B.N. Murinets-Markevich, L.M. Lyashevich, and O.A. Grishina, Cryogenic Equipment in Gynecological Practice, *Biomedical Engineering* **2** (1978).
 28. V.I. Grischenko, *Gypothermia and Cryosurgery in Obstetrics and Gynecology* (Moscow: Medicine, 1974).
 29. Max L. Hirschhorn, *Patent US 3093135*, Cooled Surgical Instrument (1963).
 30. Max L. Hirschhorn, *Patent US 3502080*, Thermoelectrically Cooled Surgical Instrument (1970).
 31. Baumgarten Frederic, *Patent FR 2613611(A1)*, Thermoelectric Effect Device and its Control and Regulating Members for Treating Cancers and other Tumours by the Method of Iterative Cryogenic Applications (1988).

32. Eidus William, *Patent US 3133539*, Thermoelectric Medical Instrument (1964).
33. L.I. Anatyshuk, Current Status and Some Prospects of Thermoelectricity, *Journal of Thermoelectricity* **2**, 7 – 20 (2007).
34. L.Ya. Kushneryk, Yu.R. Starodub, *Patent UA 53914*, Thermoelectric Cryoextractor (2003).
35. L.Ya. Kushneryk, R.V. Senyutovych, A.E. Ivansky, Thermoelectric Instrument for Surgery of Oncodiseases, *Journal of Thermoelectricity* **2**, 78 – 82 (2003).
36. L.I. Anatyshuk, O.J. Luste, L.Ya. Kushneryk, Computer Control of Temperature Distribution in Tissues at Cryosurgery and Cryotherapy, *Journal of Thermoelectricity* **4**, 75 – 79 (2006).
37. L.I. Anatyshuk, L.Ya. Kushneryk, R.V. Senyutovich, *Patent UA 84970*, Thermoelectric Hypotherm for Proctology and Oncology (2008).
38. Archie C. Hamilton, *Patent US 5207674*, Electronic Cryogenic Surgical Probe Apparatus and Method (1993).
39. Wayne F. Lisenbee, *Patent US 3993075*, Disposable, Defrostable Cryosurgical Probe Surfaces (1976).
40. Timofei S. Gudkin, *Patent US 4519389*, Thermoelectric Cryoprobe (1985).
41. Yehoshua B. Nun, *Patent US 6623479*, Cryosurgical Instrument (2003).
42. Michael Haas, *Patent US 6629417*, Hand-Held Heat Sink Cryoprobe, System for Heat Extraction Thereof, and Method Therefore (2003).
43. Yu.V. Korolev, *Patent RU 2293538*, Cryogenic Apparatus (2007).
44. M. Elfving, *Patent US 3088288*, Thermoelectric Refrigeration System (1960).
45. M.R. Holman, S.J. Rowland, Design and Development of a New Cryosurgical Instrument Utilizing the Peltier Thermoelectric Effect, *J Med Eng Technol.*, 1997.
46. H. Takeda, S. Maruyama, and J. Okajima, Development and Estimation of a Novel Cryoprobe Utilizing the Peltier Effect for Precise and Safe Cryosurgery, *Cryobiology*, 2009.
47. B. Hantash, B. Renton, and R. Berkowitz, Pilot Clinical Study of a Novel Minimally Invasive Bipolar Microneedle Radiofrequency Device, *Laser Surg. Med.*, 2009.
48. Stephen J. Rowland, *Patent US 6096032*, Medical Cryo-Surgical Device (2000).
49. L.I. Anatyshuk, R.R. Kobylanskyi, Yu.M. Mocherniuk, Thermoelectric Device for Skin Treatment, *Journal of Thermoelectricity* **4**, 86 – 92 (2009).

Submitted 20.12.2013.