

Orlovskaya S.G., Shkoropado M.S., Karimova F.F., Kalinchak V.V.

*Odessa National I.I. Mechnikov's University
E-mail: svetor@rambler.ru*

Experimental study of hydrocarbon droplets combustion

Combustion kinetics of pure hydrocarbons (n-Octadecane, n-Docosane) is studied experimentally by videomicroscopy. Burning droplets histories are obtained and analyzed. It is shown that droplet vaporization and combustion is obeyed d^2 -law. Burning rate coefficients are determined for different initial sizes of droplets.

Introduction. Fuel droplets vaporization and burning play predominant role in many combustion devices (diesel engines, industrial furnaces, incinerators), so they are studied for a long time. In recent years these processes attract scientists' attention due to development of alternative fuels. It should be mentioned the implementation of biofuel on a global scale due to increasingly strict environmental regulations. As a rule biodiesel is blended with diesel in some proportions. So the problem is to find the optimal blend. Also combustion of paraffin droplets appears to be of particular interest due to the development of paraffin-based hybrid rockets. It is found by Arif Karabeyoglu [1] that paraffin-based fuel charge is characterized by high regression rate as a result of fuel liquefying and spraying by oxidizer jet. The burning characteristics of fuel droplets are decisive for combustion chamber operation [2]. So the burning properties of paraffin droplets are wanted to design hybrid motors. It is known that paraffin is a mixture of high-molecular-weight hydrocarbons, but there is a very few data on burning properties of pure hydrocarbons with carbon number over 16. To optimize paraffin fuel composition we need quantitative data on burning properties of pure hydrocarbons with carbon numbers in the range from 17 to 26.

So this study aims at investigating combustion of n-Octadecane and n-Docosane ($C_{18}H_{38}$, $C_{22}H_{46}$) droplets in order to clarify effect of droplet size and molecular weight on burning rate.

Experiment and results. A table-top experimental setup is built to study droplet vaporization and burning kinetics by use two digital cameras. The experimental arrangement is shown below in Figure 1. The main thermal properties of the alkanes under consideration are presented in the Table below. We can see that n-Octadecane and n-Docosane are solid at room temperature so we have to a paraffin sample up to melting point in ceramic vessel in order to draw up a liquid with a syringe, and then to suspend quickly a drop on a tungsten filament loop (2). Then the drop is ignited by Ruhmkorff coil (9). During a combustion process drop burning history is recorded by two cameras: the first camera (7) images the drop itself through microscope objective (8) and the second camera (4) images its flame. The video-files from both cameras are transferred to computers (5, 6).

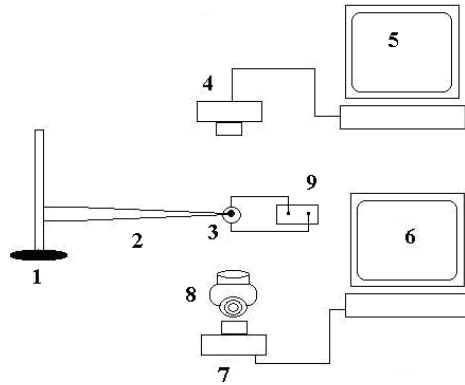

Fig. 1. The experimental setup: 1 – a droplet support; 2 – a tungsten filament loop; 3 – fuel droplet; 4, 7 – digital cameras; 5, 6 – computers; 8 – microscope objective (x16); 9 – Ruhmkorff coil.

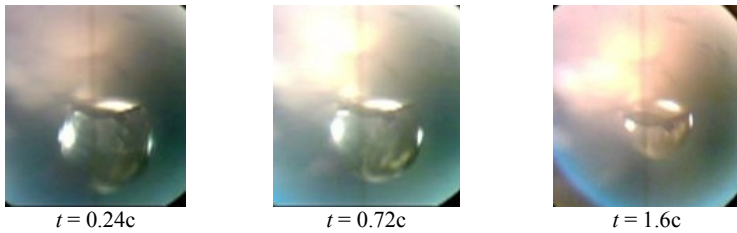

Fig. 2. Successive images of Burning Droplet (Docosane, $d_0=2.04$ mm).

In order to determine burning rates the droplets are recorded by video-camera at 30 frames per second (fps). As the combustion processes are not very fast, so it was quite enough to process from 10 to 12 fps. The obtained video-files are decoded and processed by use Image Processing Toolbox of MatLab 7.0 [3]. In Fig. 2 some successive images of burning Docosane droplet and its flame are presented.

We can see that the droplet images are blurred because of radiation of surrounding flame. So use of standard MatLab procedures of edges detection (Sobel, Prewitt or Canny methods) is complicated, and we have to select droplet edges by hand. Besides the droplet shape isn't spherical, so we define so called equivalent diameter of the droplet image, which equals to the diameter of a circle with the same area as the drop image. To convert the relative droplet size in pixels to absolute value in mm we use a tungsten filament ($d = 0.114$ mm) as a reference scale. Then we calculate a squared diameter values, transform it to dimensionless form $d^2(t)/d_0^2$ and build graphs for different droplet initial diameters (Fig.3).

To calculate a burning rate coefficient we determine linear approximation equation by use a least-squares regression, minimizing the random error in measurement of droplet diameter. The calculated values of burning rate coefficients of Octadecane and Docosane droplets for two values of initial diameter are presented in Table 1.

It is seen that burning rate constant of Octadecane is higher than one of Docosane, that is the combustion rate of hydrocarbon decreases with molecular weight increase. To explain this fact we should use the data on basic thermal properties of n-Octadecane and n-Docosane (Table 1). The combustion heats of this alkanes are slightly different (less than one percent), but the difference between vaporization heats is more pronounced (about 12%). Also boiling points of these alkanes differs by 50°C. As fuel evaporation is limiting stage of droplet combustion in conditions of our experiment, so the Octadecane droplets ignites more easily and burns away faster than those of Docosane.

Conclusions. The combustion kinetics of pure hydrocarbons (Octadecane and Docosane) droplets is studied experimentally and the burning rate coefficients are determined for different initial sizes of droplets. The dependence of burning coefficient on initial droplet diameter is established. It is found that increase in droplet initial diameter leads to significant rise of burning rate coefficient. This fact is explained by strong influence of natural convection on hydrocarbon vapor mass transfer. It is shown that burning rate of n-Octadecane significantly exceeds the one of n-Docosane. This fact is explained by lower values of vaporization heat and boiling point of Octadecane.

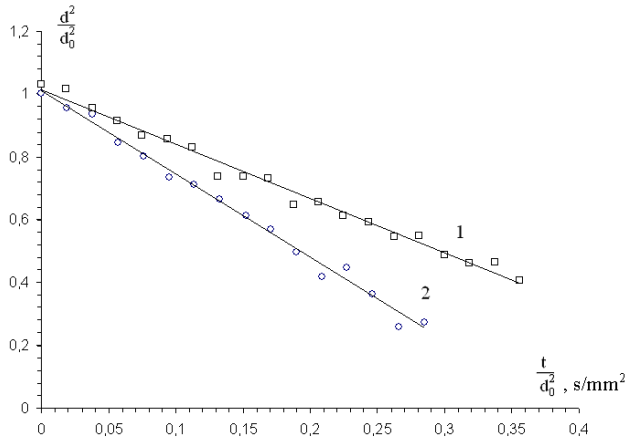

Fig.3. Squared diameters of burning droplets ($d_0 = 1.87 \text{ mm}$):
○ – Docosane; ■ – Octadecane.

Table 1. The burning rate coefficients of hydrocarbon droplets.

Initial droplet diameter, mm	K_{bur} , mm^2/s	
	n-Octadecane	n-Docosane
1.87	1.43	2.59
2.04	1.22	1.61

Table 2. The basic properties of n-Octadecane and n-Docosane.

Hydrocarbon	n-Octadecane	n-Docosane
chemical formula	$\text{C}_{18}\text{H}_{38}$	$\text{C}_{22}\text{H}_{46}$
Molar mass, g/mole	254.5	310.6
Density, g/ml (at 25 °C)	0.777	0.778
Melting point, T_m , °C	28	44
Boiling point, T_b , °C	316	369
Heat of vaporization, kJ/kg	356	399.2

References:

1. *Karabeyoglu M.A., Cantwell B.J., Altman D.* Development and Testing of Paraffin-based Hybrid Rocket Fuels// AIAA 2001-4503.
2. *Scott Poll, David Iverson, Jeremy Ou, Dwight Sanderfer, Ann Patterson-Hine.* System Modeling and Diagnostics for Liquefying-Fuel Hybrid Rockets // NASA / TM-2003-212270.
3. *Дьяконов В.П., Абраменкова И.В.* MATLAB. Обработка сигналов и изображений. Специальный справочник. – С.Пб.: Питер, 2002. – 608 с.
4. *Orlovskaya S.G., Shkoropado M.S., Karimova F.F.* Burning characteristics of paraffin based fuel.//Dusty Plasmas in Applications. 4th International Conference on the Physics of Dusty and Burning Plasmas. Odessa. August 25-29. 2013. – P.79-83.

Орловська С.Г., Шкоропато М.С., Карімова Ф.Ф., Калінчак В.В.

Експериментальне дослідження горіння вуглеводневих крапель

АНОТАЦІЯ

Експериментально досліджено кінетику горіння вуглеводневих крапель (октадекан, докозан) із застосуванням методу відеомікроскопії. Доказано, що квадрат діаметру палаючих крапель лінійно змінюється з часом. Знайдено коефіцієнти швидкості горіння крапель з різними початковими діаметрами. Встановлено, що швидкість горіння октадекану помітно перевищує швидкість горіння докозану.

Орловская С.Г., Шкоропато М.С., Каримова Ф.Ф., Калинин В.В.

Экспериментальное исследование горения углеводородных капель

АННОТАЦИЯ

Кинетика горения углеводородов (октадекан, докозан) экспериментально исследована с использованием метода видеомикроскопии. Доказано, что квадрат диаметра горящих капель линейно зависит от времени. Найдены коэффициенты скорости горения капель разных начальных диаметров. Установлено, что скорость горения октадекана заметно превышает скорость горения докозана.