

UDK 531.768

Chernyak N. G. , Rybak V. V. , Terokhin S. V.

**INSTRUMENTAL ERRORS OF NAVIGATION ACCELEROMETER
NONLINEAR METROLOGICAL MODEL'S COEFFICIENTS
IDENTIFICATION BY TEST-POSITIONING METHOD IN
TERRESTIAL GRAVITATIONAL FIELD**

Introduction

Navigation pendulous accelerometers (NA) are the sensors of the primary information of practically all contemporary strapdown inertial navigation systems (SINS) and orientation systems (SSO). It is well-known fact that accelerometer's drifts affect greatly on errors in tasks solved by SINS and SSO.

By accelerometer's metrological model (MM) we understand the mathematical formula for estimation of the projection of the apparent linear acceleration value with assigned accuracy by the measuring of accelerometer's output signals meaning. Coefficients of this metrological model are the individual certificated coefficients of NA which are identified (defined experimentally) by the results of NA's calibration.

The works [1], [2], [3] are devoted to problem of identification of MM's coefficients determination by test-positioning method in terrestrial gravitation field. Article [1] deals with nonlinear MM of uniaxial NA and proposes model of determination of its coefficients. It was received by approximate solving of nonlinear equation set that caused methodical errors of coefficients identification. The problem of methodical errors was solved in [2] where received the model of determination of coefficients of accelerometer's metrological model from [3]. Expressions for calculation of MM's coefficients values in [2] were received analytically without any approximation or numerical solving of sets of equations; therefore, there are no methodic errors of coefficient's determination.

However, still unsolved are problem of instrumental drifts of MM's coefficients determination and problem of assigned accuracy of identification by making demands on the stand equipment that is used for calibration.

Problem statement

The purpose of this article is to solve next problems:

- developing of a mathematical model of instrumental errors of navigation accelerometer metrological model's coefficients identification;
- ensuring of the accuracy of MM's coefficients identification by making demands on the on the stand equipment that is used for its calibration.

Metrological model of NA and expressions for determination of its coefficients

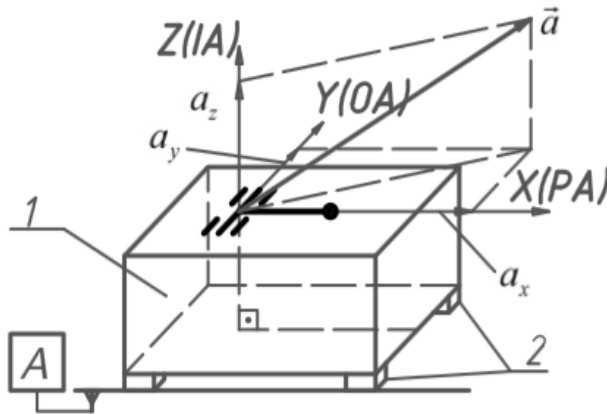

Fig. 1. Uniaxial navigation accelerometer

Let's solve the stated problems for metrological model defined in [3] for pendulous NA shown on fig. 1. where: 1 – NA's housing; 2 – housing elements which define a NA's basic mounting surface A; $OXYZ$ – coordinate associated with surface A and OX – pendulous axis (PA), OY – output axis (OA); OZ – input axis (IA) orthogonal to the surface A.

This model in the units of input acceleration can be represented as following

$$a_{iP} = \hat{a}_i - k_{0\Sigma} - 0,5k_{1A}\hat{a}_i \text{sign}\hat{a}_i - k_2\hat{a}_i^2 - k_3\hat{a}_i^3 - \delta_o\hat{a}_p - \delta_p\hat{a}_o - \delta_{ip}\hat{a}_i\hat{a}_p, [g], \quad (1)$$

$$k_{1A} = (K_{1+} - K_{1-})K_1^{-1},$$

where

a_{iP} – calculated after NA's metrological model value of input acceleration;

a_o, a_p – projections of apparent acceleration on output (OA) and pendulous (PA) axis of NA;

$\hat{a}_i = \hat{Y}_i / K_1$ – estimation of the test NA's output signal in input acceleration units;

$\hat{a}_{o(p)} = \hat{Y}_{o(p)} / K_1$ – estimation of the output signal of other accelerometers of navigation system whose IAs oriented along the OA (\hat{a}_o) and PA (\hat{a}_p) of the test NA, in input acceleration units;

K_1 – scale factor (SF) of the accelerometer;

K_{1+}, K_{1-} – real scale factors when $a_i > 0$ and $a_i < 0$;

k_{1A} – certificated factor of SF asymmetry;

$k_{0\Sigma}$ – certificated zero offset factor;

k_2, k_3 – certificated nonlinearity factors;

δ_p, δ_o – certificated factors of additive cross sensitivity;

δ_{ip} – certificated factor of multiplicative cross sensitivity.

According to the [3], MM's coefficients are determined by method of NA test-positioning in terrestrial gravitation field described in [2]. The method is in placing of accelerometer into 8 test positions (TP) relatively to the horizon plane (HP) with the help of precise uniaxial swivel stand (for example optical index head (OIH)). Each position is formed by rotation angle of NA relatively to

the HP $\varphi_j, (j = \overline{1,8})$, where j – test position number that begins from $\varphi_1 = 0^\circ$ with 45° step), defined by the following formula

$$\varphi_{j+1} = \varphi_j + 45^\circ, (j = \overline{1,7}). \quad (2)$$

In each testing position output signals rates of NA Y_j are measured and then they are used for calculation of numeric values of appropriate MM's coefficients according to the next expressions:

$$\begin{aligned} K_{1-} &= \frac{1}{-3g} [Y_5 + \sqrt{2}(Y_4 + Y_6) - 0,5(1 + 2\sqrt{2})(Y_3 + Y_7)], [B/g]; \\ K_{1+} &= \frac{1}{3g} [Y_1 + \sqrt{2}(Y_2 + Y_8) - 0,5(1 + 2\sqrt{2})(Y_3 + Y_7)], [B/g]; \\ K_1 &= 0,5(K_{1+} + K_{1-}), [B/g]; \\ k_2 &= \frac{1}{2K_1g^2} [Y_2 + Y_4 + Y_6 + Y_8 - 4K_1k_{0\Sigma}], [1/g]; \quad k_{0\Sigma} = \frac{(Y_3 + Y_7)}{2K_1}, [g]; \\ k_3 &= \frac{\sqrt{2}}{K_1g^3} [Y_6 - Y_2 + \sqrt{2}gK_1(1 - \delta_o)], [1/g^2]; \quad \delta_{o(p)} = \frac{Y_7 - Y_3}{2K_1g}, [1]; \\ \delta_{ip} &= \frac{1}{2K_1g^2} [Y_8 + Y_4 - Y_2 - Y_6], [1/g]. \end{aligned} \quad (3)$$

Mathematical model of instrumental errors of navigation accelerometer metrological model's coefficients identification

Authors of article [3] have developed formulas (3) analytically without any approximations or numerical solving of equations set. Therefore, values of appropriate coefficients defined by those formulas do not contain methodic errors. In this case, only instrumental errors will appear during the coefficient identification with the help of expressions (3). The causes of these errors are drifts of calibration equipment. According to the NA test-positioning method [2], [3], there are only two sources of sought instrumental errors: error of NA positioning relatively to the HP and error of NA's output signal measurement. Total influence of both this errors causes the effect when practical values of NA's output signals in each position differs from the ideal (when errors of positioning NA and measuring of its output signals are absent) ones on the value of ΔY_j . Let's write formulas (3) taking into consideration that fact:

$$\begin{aligned}
K_{1-\phi} &= \frac{1}{-3g} \left[(Y_5 + \Delta Y_5) + \sqrt{2}(Y_4 + Y_6 + \Delta Y_4 + \Delta Y_6) - \right. \\
&\quad \left. -0,5(1 + 2\sqrt{2})(Y_3 + Y_7 + \Delta Y_3 + \Delta Y_7) \right] = \\
&= K_{1-} - \frac{1}{3g} \left[\Delta Y_5 + \sqrt{2}(\Delta Y_4 + \Delta Y_6) - 0,5(1 + 2\sqrt{2})(\Delta Y_3 + \Delta Y_7) \right]; \\
K_{1+\phi} &= K_{1+} + \frac{1}{3g} \left[\Delta Y_1 + \sqrt{2}(\Delta Y_2 + \Delta Y_8) - 0,5(1 + 2\sqrt{2})(\Delta Y_3 + \Delta Y_7) \right], [B/g]; \\
k_{0\Sigma\phi} &= k_{0\Sigma} + \frac{\Delta Y_3 + \Delta Y_7}{2K_1}, [g]; \quad k_{3\phi} = k_3 + \frac{\sqrt{2}}{K_1 g^3} [\Delta Y_6 - \Delta Y_2], [1/g^2]; \\
\delta_{o\phi(p\phi)} &= \delta_{o(p)} - \frac{\Delta Y_7 - \Delta Y_3}{2K_1 g}, [1]; \quad k_{2\phi} = k_2 + \frac{1}{2K_1 g^2} [\Delta Y_2 + \Delta Y_4 + \Delta Y_6 + \Delta Y_8], [1/g]; \\
\delta_{ip\phi} &= \delta_{ip} + \frac{1}{2K_1 g^2} [\Delta Y_8 + \Delta Y_4 - \Delta Y_2 - \Delta Y_6], [1/g].
\end{aligned} \tag{4}$$

Every expression of set (4) consists of two parts. One part matches expressions (3) and second one is additional parts that depends on the added errors ΔY_j . These parts will determine sought errors of MM's coefficients identification. We represent them with the help of following expressions:

$$\begin{aligned}
\delta_{K1} &= \frac{(K_{1+\phi} - K_{1+}) + (K_{1-\phi} - K_{1-})}{2K_1} = \\
&= \frac{1}{12K_1 g} \left[\Delta Y_1 - \Delta Y_5 - \sqrt{2}(\Delta Y_2 + \Delta Y_8 - \Delta Y_4 - \Delta Y_6) \right], [1]; \\
\delta_{K2} &= \frac{1}{2K_1 k_2 g^2} [\Delta Y_2 + \Delta Y_4 + \Delta Y_6 + \Delta Y_8], [1]; \\
\delta_{Mip} &= \frac{1}{2K_1 \delta_{ip} g^2} [\Delta Y_8 + \Delta Y_4 - \Delta Y_2 - \Delta Y_6], [1]; \quad \Delta_0 = \frac{\Delta Y_3 + \Delta Y_7}{2K_1}, [g]; \\
\delta_{Mo(Mp)} &= \frac{\Delta Y_7 - \Delta Y_3}{2K_1 \delta_{o(p)} g}, [1]; \quad \delta_{K3} = \frac{\sqrt{2}}{K_1 k_3 g^3} [\Delta Y_6 - \Delta Y_2], [1].
\end{aligned} \tag{5}$$

In formulas (5) were used following designations: Δ_0 – error of zero offset factor identification; δ_{K1} – relative error of scale factor identification; δ_{K2}, δ_{K3} – relative errors of nonlinearity factors identification; δ_{Mo}, δ_{Mp} – relative errors of additive cross sensitivity factors identification; δ_{Mip} – relative error of multiplication cross sensitivity factor identification.

To find ΔY_j let's consider its sources – random error of NA's output signal measurement ΔY_B and error of NA's positioning relatively to the HP. The last one, according to the fig. 2, includes systematic (the same in every position) errors of initial leveling (β_1, β_2) and random error of testing position assignment ($\Delta\varphi$).

On the fig. 3 are shown: 1 – shaft of the OIH that serves as a dial of NA test positions relatively to the HP; 2 – platform connected with shaft on which NA is mounted; 3 – test NA; φ - rotation angle around the axis of shaft that is equal to the angle φ_j (2); $OX_\Gamma Y_\Gamma Z_\Gamma$ – coordinates associated with the horizontal plane, and OY_Γ axis is in the HP codirectional to the OIH's shaft spinning axis, OZ_Γ axis is perpendicular to the HP; $OX_\Pi Y_\Pi Z_\Pi$ - coordinates associated with the platform for NA mounting, and OY_Π is the spinning axis of the OIH' shaft, OZ_Π axis is perpendicular to the basic mounting surface B of the platform. During the calibration, NA is mounted on the platform so that its input axes parallel to the platform's axes OZ_Π and axes OA and PA are correspondingly parallel to the axes OY_Π and OX_Π .

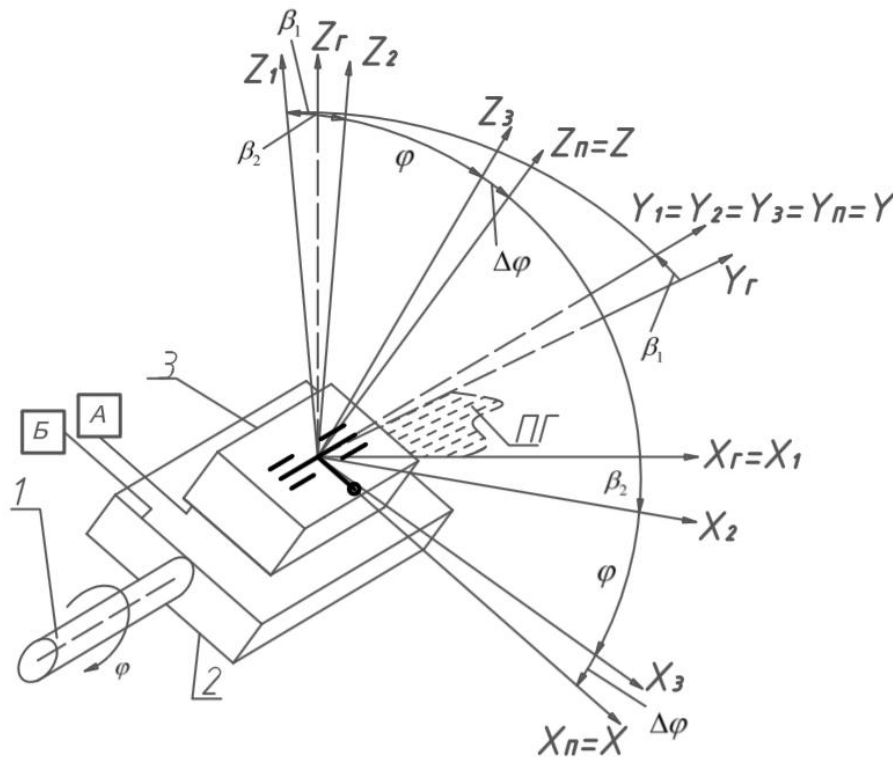

Fig. 2. Orientation of accelerometer axis $OXYZ$ relatively to the HP when errors of its positioning exist

According to the fig. 2, projections of apparent linear acceleration on the axis of the accelerometer in position j in first approximation (for small angle $\Delta\varphi, \beta_1, \beta_2$) have the following form:

$$a_{ij} = -g_{ij} \approx g \left[\cos \varphi_j - (\beta_2 \pm \Delta\varphi) \sin \varphi_j \right]; \quad (6)$$

$$a_{pj} = -g_{pj} \approx -g((\beta_2 \pm \Delta\varphi)\cos\varphi_j + \sin\varphi_j); \quad a_{oj} = -g_{oj} \approx g\beta_1.$$

To find the differences ΔY_j let's determine the difference between real and ideal output signals of NA in each test position. Expression for the real output signals can be found by placing of the expressions (6) into MM of NA's output signal

$$\begin{aligned} Y_{j\varphi} = & K_1(k_{0\Sigma} + (1 + 0,5k_{1A}\text{sign}a_i)(\cos\varphi_j - (\beta_2 \pm \Delta\varphi)\sin\varphi_j)g + \\ & + k_2(\cos\varphi_j - (\beta_2 \pm \Delta\varphi)\sin\varphi_j)^2 g^2 + k_3(\cos\varphi_j - (\beta_2 \pm \Delta\varphi)\sin\varphi_j)^3 g^3 - \\ & - \delta_o g((\beta_2 \pm \Delta\varphi)\cos\varphi_j + \sin\varphi_j) + \delta_p g\beta_1 - \\ & - \delta_{ip}(\cos\varphi_j - (\beta_2 \pm \Delta\varphi)\sin\varphi_j)((\beta_2 \pm \Delta\varphi)\cos\varphi_j + \sin\varphi_j)g^2) \pm \Delta Y_B, [B]. \end{aligned} \quad (7)$$

Expression that describe output signals of the NA in ideal case can be found by equating values of β_1, β_2 and $\Delta\varphi$ errors to zeros

$$\begin{aligned} Y_j = & K_1(k_{0\Sigma} + (1 + 0,5k_{1A}\text{sign}a_i)g \cos\varphi_j + k_2 g^2 \cos^2\varphi_j + \\ & + \delta_{ip}(\cos\varphi_j - (\beta_2 \pm \Delta\varphi)\sin\varphi_j)((\beta_2 \pm \Delta\varphi)\cos\varphi_j + \sin\varphi_j)g^2) \pm \Delta Y_B, [B] \end{aligned} \quad (8)$$

The difference between (7) and (8) is the sought difference of output signals ΔY_j in each test position

$$\begin{aligned} \Delta Y_j = & K_1(k_{0\Sigma} - (1 + 0,5k_{1A}\text{sign}a_i)((\beta_2 \pm \Delta\varphi)\sin\varphi_j)g - k_2((\beta_2 \pm \\ & \pm \Delta\varphi)\sin\varphi_j)^2 g^2 - k_3((\beta_2 \pm \Delta\varphi)\sin\varphi_j)^3 g^3 - \delta_o g((\beta_2 \pm \Delta\varphi)\cos\varphi_j) + \\ & + \delta_p g\beta_1 - \delta_{ip}((\beta_2 \pm \Delta\varphi)\sin\varphi_j)((\beta_2 \pm \Delta\varphi)\cos\varphi_j)g^2) \pm \Delta Y_B, [B]. \end{aligned} \quad (9)$$

Let's find the expressions for the MM's coefficients identification errors from the error of NA's in dependence on output signal measurement ΔY_B , errors of initial leveling (β_1, β_2) and error of testing position assignment ($\Delta\varphi$). To do this we substitute (9) into (5) taking into consideration the random nature of errors ΔY_B and $\Delta\varphi$. It allows use geometric sum instead of algebraic one. For each test position choose appropriate value of angle φ_j calculated by the formula (2) beginning from the initial horizontal value. As the result we receive, in first approximation relatively to the K_1 value, following expressions for sought identification errors calculation:

$$\begin{aligned} \delta_{K3} = & \sqrt{\frac{2}{g^4 k_3^2} \Delta\varphi^2 + \frac{1}{g^6 K_1^2 k_3^2} \Delta Y_B^2}, [1]; \\ \delta_{K2} = & \sqrt{\frac{1}{32} \Delta\varphi^2 + \frac{1}{16 g^4 K_1^2 k_2^2} \Delta Y_B^2}, [1]; \quad \delta_{K1} = \sqrt{\frac{1}{18} \Delta\varphi^2 + \frac{1}{27 g^2 K_1^2} \Delta Y_B^2}, [1]; \end{aligned} \quad (10)$$

$$\Delta_0 = \sqrt{\frac{g^2}{8} \Delta\varphi^2 + \frac{1}{8K_1^2} \Delta Y_B^2}, [g];$$

$$\delta_{Mo(Mp)} \approx -\beta_{2(1)} \frac{1}{\delta_{o(p)}} + \sqrt{\frac{1}{8\delta_{o(p)}^2} \Delta\varphi^2 + \frac{1}{8g^2 K_1^2 \delta_{o(p)}^2} \Delta Y_B^2}, [1];$$

$$\delta_{Mip} = \sqrt{\frac{1}{32} \Delta\varphi^2 + \frac{1}{16g^4 K_1^2 \delta_{ip}^2} \Delta Y_B^2}, [1].$$

Expressions (10) are the mathematical model of instrumental errors of navigation accelerometer metrological model's coefficients identification by test-positioning method in terrestrial gravitational field. Their analysis shows that identification errors of all MM's coefficients depend only from error of testing position assignment ($\Delta\varphi$) and error of NA's output signal measurement ΔY_B . Errors of initial leveling β_1, β_2 influence only on the tolerance of cross sensitivity factors identification.

By formulas (10) can be calculated the instrumental errors of navigation accelerometer metrological model's (1) coefficients identification depending on the certificated calibration equipment's drifts ($\beta_1, \beta_2, \Delta\varphi$ and ΔY_B).

Ensuring of the accuracy of MM's coefficients identification

In case, when in the calibration task are demands on allowable errors of metrological model's coefficient identification, namely specified: $[\Delta_0]$ – allowable error of zero offset factor identification; $[\delta_{K_1}]$ – allowable relative error of scale factor identification; $[\delta_{Mo}], [\delta_{Mp}]$ – allowable relative errors of additive cross sensitivity factors identification; $[\delta_{Mip}]$ – allowable relative error of multiplication cross sensitivity factor identification. In this situation, expressions (10) help to find demands on calibration equipment tolerance that ensures specified requirements.

Let's find those demands. To do that, from (10) find the expressions that relate calibration equipment drifts ($\beta_1, \beta_2, \Delta\varphi$ and ΔY_B) to allowed MM's coefficient identification errors, specified in the calibration task. At first let's make a demand to the test position assignment. To do that, we omit the influence of errors β_1, β_2 and ΔY_B in formulas (10) by implementation of following conditions:

$$A^2 \Delta Y_B^2 \leq 0,1 B^2 \Delta\varphi^2; \quad C \beta_{1(2)} \leq B \Delta\varphi, \quad (11)$$

where A^2, B^2, C – corresponding coefficients near the $\Delta Y_B^2, \Delta\varphi^2$ and $\beta_{1(2)}$ in the expressions (10).

Ensuring of conditions (11) allows get a following set of inequalities that characterize demands on the error of testing position assignment $\Delta\varphi$:

$$\begin{aligned} \Delta\varphi_{K1} &\leq 3\sqrt{2}[\delta_{K1}]; & \Delta\varphi_{K0} &\leq \frac{2\sqrt{2}}{g}[\Delta_0]; \\ \Delta\varphi_{K2} &\leq \frac{8}{\sqrt{2}}[\delta_{K2}]; & \Delta\varphi_{K3} &\leq \frac{g^2 k_3}{\sqrt{2}}[\delta_{K3}]; & \Delta\varphi_{Mip} &\leq \frac{8}{\sqrt{2}}[\delta_{Mip}]; \\ \Delta\varphi_{Mo(Mp)} &\leq 2\sqrt{2}[\delta_{Mo(Mp)}]; \end{aligned} \quad (12)$$

In expressions (12) and further indexes $K0, K1, K2, K3, Mip, Mo, Mp$ refer to the corresponding MM's NA coefficient which identification tolerance determines corresponding allowable calibration equipment's drifts.

To find demands on tolerance of NA's output signals meter and demands on leveling accuracy it is necessary to solve inequalities (11) relative to β_1, β_2 and ΔY_B for every coefficient. As the result we receive the following inequalities sets:

$$\beta_{2Mo} \leq \delta_o[\delta_{Mo}]; \quad \beta_{1Mp} \leq \delta_p[\delta_{Mp}]; \quad \Delta Y_{BK1} \leq 3\sqrt{3}gK_1[\delta_{K1}]; \quad (13)$$

$$\begin{aligned} \Delta Y_{BK0} &\leq 2\sqrt{2}K_1[\Delta_0]; & \Delta Y_{BK2} &\leq 4g^2 K_1 k_2[\delta_{K2}]; \\ \Delta Y_{BK3} &\leq g^3 K_1 k_3[\delta_{K3}]; & \Delta Y_{BMo(p)} &\leq 2\sqrt{2}gK_1 \delta_{o(p)}[\delta_{Mo(p)}]; \\ \Delta Y_{BMip} &\leq 4g^2 K_1 \delta_{ip}[\delta_{Mip}]. \end{aligned} \quad (14)$$

Inequalities sets (12...14) allow determine demands on allowable calibration equipment's drifts as sources of instrumental errors of navigation accelerometer metrological model's coefficients identification in case of specification of allowable errors of identification of those coefficients.

Example of obtained results use

As an example of obtained results use considers the calibration by model (1) of navigational accelerometer with the tensoresistance angle sensor (TAS) that was studied in article [2]. There were determined the following numerical values of its metrological model certificated coefficients:

$$\begin{aligned} K_1 &= 1,5[B/g]; \\ k_2 &= 105[\mu g/g^2]; & k_3 &= 87[\mu g/g^3]; & \delta_o &\approx \delta_p \approx \delta_{ip} = 1,15 \text{ мрад.} \end{aligned} \quad (15)$$

Let, according to the calibration task, it is necessary to ensure identifications of those coefficients with following allowable errors:

$$[\Delta_0] = \pm 50 \mu g; \quad [\delta_{K1}] = \pm 0,01 \%; \quad [\delta_{K2(3)}] = \pm 5 \%; \quad (16)$$

$$\left[\delta_{Mo(Mp, Mip)} \right] = \pm 1 \%$$

After substitution of allowable identification errors values (16) and numerical coefficient valued into formulas (12-14) we can find the corresponding calibration equipment's drifts limits.

$$\begin{aligned} \Delta Y_{BK1} &\leq 0,75 \text{ мВ}; & \Delta Y_{BK0} &\leq 40 \text{ мкВ}; & \Delta Y_{BK2} &\leq 31 \text{ мкВ}; \\ \Delta Y_{BK3} &\leq 6 \text{ мкВ}; & \Delta Y_{BMo(p)} &\leq 49 \text{ мкВ}; & \Delta Y_{BMip} &\leq 70 \text{ мкВ}; & \beta_{1Mp} &\leq 2,5''; \\ \beta_{2Mo} &\leq 2,5''; & \Delta \varphi_{K1} &\leq 86''; & \Delta \varphi_{K0} &\leq 30''; & \Delta \varphi_{Mo(Mp)} &\leq 1,7^\circ; & \Delta \varphi_{K2} &\leq 16,8^\circ; \\ & & \Delta \varphi_{K3} &\leq 6''; & \Delta \varphi_{Mip} &\leq 3,3^\circ. \end{aligned} \quad (17)$$

From the inequalities (17) demands on identification tolerance (16) should be achieved if the calibration equipment's drifts will not exceed the following values:

$$\begin{aligned} \Delta \varphi = \Delta \varphi_{K3} &\leq 6''; & \beta_1 = \beta_{1Mp} &\leq 2,5''; & \beta_2 = \beta_{2Mo} &\leq 2,5''; \\ \Delta Y_B = \Delta Y_{BK3} &\leq 6 \text{ мкВ}. \end{aligned} \quad (18)$$

Requirements (18) are the numerical values of maximal allowable calibration equipment's drifts. They show that error of testing position assignment $\Delta \varphi$ and error of NA's output signal measurement ΔY_B are determined by allowable identification error of cube nonlinearity factor $[\delta_{K3}]$. Errors of initial leveling β_1, β_2 are determined by allowable identification error of additive cross sensitivity factors $[\delta_{Mo}], [\delta_{Mp}]$.

To confirm the realization of calibration task when demands on calibration equipment's drifts (18) are provided the experiment has been done. The experiment was to calibrate NA with TAS, which numerical MM's coefficients values had been determined beforehand. Calibration algorithm described in [3] and requires equipment shown on fig. 3, where: 1 - foundation, untied from a construction 2; 3 – OIH; 4 – OIH's shaft; 5 - type of heat chamber TWT-2; 6 – NA's power source; 7 – precision voltmeter; 8 – computer; A1, A2, A3 – NA, which MM's coefficients are determined; IA1, IA2, IA3 – input axes of appropriate NA.

In the experiment, the numerical values of MM's NA coefficients were determined. After that, the errors of their identification were calculated by subtraction from the founded numerical coefficients values their reference values (15).

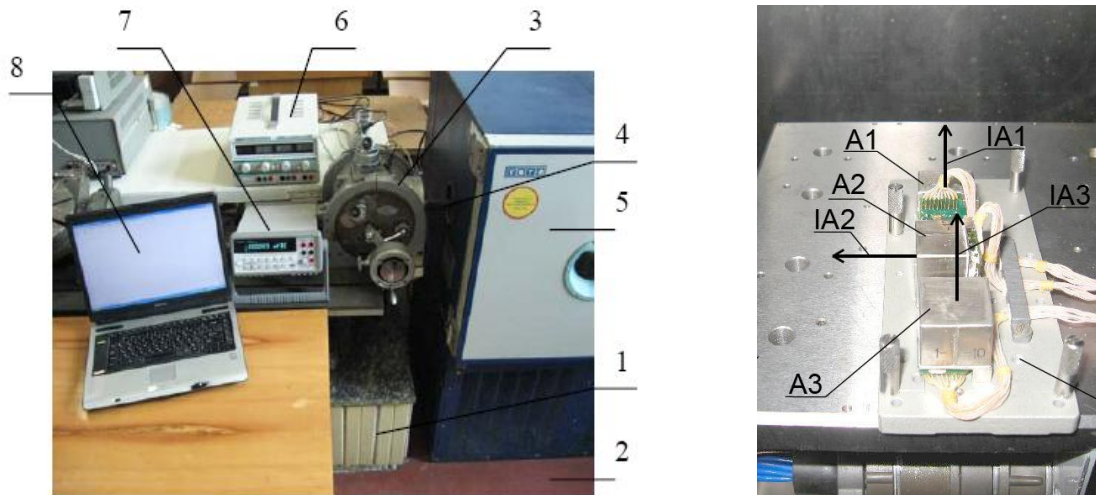

Fig. 3. Calibration equipment

At first case, conditions (18) were provided by choosing of appropriate calibration equipment, precise test position alignment and precise initial leveling. At second case, test positions of NA relatively to the HP were not precise ($\Delta\varphi = 50''$), initial leveling was not precise too ($\beta_{1(2)} = 20''$) and voltmeter with bigger drifts had been chosen. As the result, we got numerical values of MM's coefficients identification errors for each case that are written in table.

Table.

MM's NA coefficients identification errors

Errors	$\Delta_0, [\mu g]$	$\delta_{K1}, [\%]$	$\delta_{K2}, [\%]$	$\delta_{K3}, [\%]$	$\delta_{Mo(p)}, [\%]$	$\delta_{Mip}, [\%]$
Case 1.	12,3	0,001	1,5	4,5	1	0,005
Case 2.	70	0,005	20	53	4	0,02

Comparing values of MM's NA coefficients identification errors from tab. 1 in each case with their allowable ones (16) we can see that provision of conditions (18) ensures the specified accuracy of MM's NA coefficients identification. If conditions (18) are not provided, errors $\Delta_0, \delta_{K2}, \delta_{K3}$ and $\delta_{Mo(p)}$ will exceed their allowable values greatly. However, errors δ_{K1} та δ_{Mip} still remain in appropriate limits.

Conclusions

Mathematical model (10) of instrumental errors of navigation accelerometer nonlinear metrological model's (1) coefficients identification developed in this article shows that calibration equipment's errors $\Delta\varphi$ and ΔY_B influence on tolerance of identification of all MM's (1) coefficients and errors β_1 and β_2 influence only on tolerance of identification of additive cross sensitivity factors. Moreover, influence of $\Delta\varphi$ error on total error of

identification of MM's NA coefficient almost does not depend on numerical values of those coefficients, and influence of ΔY_B error depends from those coefficients numerical values inversely. This fact makes the ensuring of MM's NA coefficients identification tolerance much more complicated because identification of the small numerical values of MM's coefficients require calibration equipment with higher tolerance.

Choosing of stand equipment that is used for calibration of NA by its nonlinear metrological model (1) accordingly to the conditions (12...14), ensures identification with assigned accuracy of all its metrological model coefficients.

References

1. *Устюгов М. Н.* Калибровка акселерометра бесплатформенной инерциальной навигационной системы / М. Н. Устюгов, М. А. Щипицына// Вестник ЮУрГУ, №14,2006 – С. 140-143.
2. *Черняк Н. Г., Хазинедарлу Э.* Калибровка навигационного маятникового акселерометра методом тестовых поворотов в гравитационном поле Земли// Механіка гіроскопічних систем.- научн.-техн. збірник.- Київ, 2009.-Вип. 20.- С.81-91.
3. *Черняк Н. Г., Хазинедарлу Э.* Исследование метрологических характеристик навигационного маятникового компенсационного акселерометра с трансформаторным датчиком угла// Інформаційні системи, механіка та керування.- наук.-техн. збірник.- Київ, 2009.-Вип. 3.- С.5-20.