

UDK 664.114.01:[635.12+635.14]-035.2:543.92

## TECHNOLOGICAL ASPECTS OF PRODUCTION OF THE CANDIED FRUITS FROM NON-TRADITIONAL RAW MATERIAL

I.R. Belenkaya, Assistant Professor, E-mail: foodprofi@gmail.com

Ya.A. Golinskaya, graduate student, E-mail: golinskaya.yana@mail.ru

Department of Technology of restaurant and health food

Odessa National Academy of Food Technologies, Odessa, Kanatna street, 112, Ukraine, 65039

**Abstract.** The article analyses the candied fruit market in Ukraine and describes the main technological operations pertaining to processing of non-traditional candied products – celery and parsnip roots. Darkening of the roots surface caused by the enzyme oxidation is one of the problems arising when processing white roots, which leads to worse marketable condition of the product. To prevent darkening, the developed technology provides for soaking raw material in 1% citric acid solution immediately after peeling. To improve the diffusion and osmotic processes and to soften roots before boiling in sugar syrup, the steam blanching has been applied. The constructed Gantt diagram proves that the developed technology can shorten the candied fruit cooking period. The biochemical indicators of the obtained new products have been studied. It was established that the candied fruit possess the appropriate physical and chemical indicators and original organoleptic properties resulting in a demand by consumers. The results of the taste evaluation of the experimental specimen confirmed a high quality of the products.

**Key words:** celery and parsnip roots, candied products, technology, Gantt diagram, organoleptic indicators.

## ТЕХНОЛОГІЧНІ АСПЕКТИ ВИРОБНИЦТВА ЦУКАТІВ З НЕТРАДИЦІЙНОЇ СИРОВИНИ

I.P. Біленька., к.т.н., доцент, E-mail: foodprofi.onaft@gmail.com

Я.А.Голінська, аспірант, E-mail: golinskaya.yana@mail.ru

\*Кафедра технології ресторанного і оздоровчого харчування

Одеська національна академія харчових технологій, вул. Канатна, 112, м. Одеса, Україна, 65039

**Анотація.** У статті проаналізовано ринок цукатів в Україні, викладено основні технологічні операції з переробки нетрадиційної для цукатів сировини – коріння селери та пастернаку. Однією з проблем при технологічній переробці білих коренів є потемніння поверхні коренеплодів через ферментативне окиснення, що призводить до погіршення товарного виду продукту. Для попередження потемніння за розробленою технологією передбачено замочування сировини у 1 %-вому розчині лимонної кислоти одразу після очищення. Для поліпшення протікання дифузійно-осмотичних процесів, а також розм'якшення коренеплодів перед уварюванням у цукровому сиропі, застосовано бланшування парюю. Побудовано діаграму Ганта, яка доводить, що розроблена технологія дозволяє скоротити час приготування цукатів. Вивчені біохімічні показники отриманих нових продуктів. Проведено експертну оцінку цукатів за органолептичними властивостями. Встановлено, що цукати мають належні фізико-хімічні показники та оригінальні органолептичні властивості, внаслідок чого будуть користуватися попитом у споживачів. Результати дегустаційної оцінки експериментальних зразків підтвердили високу якість продуктів.

**Ключові слова:** коріння селери, пастернаку, цукати, технологія, діаграма Ганта, органолептичні показники.



Copyright © 2015 by author and the journal "Food Science and Technology".

This work is licensed under the Creative Commons Attribution International License (CC BY).

<http://creativecommons.org/licenses/by/4.0>

### Introduction

The food industry of Ukraine increases output of sweet products rather dynamically [1]. Candied fruit made of non-traditional raw products such as white roots used for cooking desserts is a promising direction for extending the product range, upgrading their nutritional value and improvement of the organoleptic indicators of such kind of products.

Spicy taste and peculiar flavour of celery and parsnip roots are due to a high content of ether oils (to 0.5 %) which include octyl ether of oleic acid as well as the ethers of propionic, heptylic and butylacetic acids. Flavours of these raw materials: alcohols, ether oils, volatile acids and aldehydes contribute to special peculiar odour and evoke human organism, including appetite [2].

Besides good taste and flavour, the celery and parsnip roots as well as the dishes cooked on their basis possess such health-promoting properties as digestion improvement and better food consumption, awakening of appetite, diuretic action, strengthening of blood vessels and immunity reinforcement, support of the respiratory system performance and restorative effect [2].

The existing methods of candied fruit production are characteristic of long lasting processes, particularly of blank boiling, considerable energy consumption, loss of vitamins and other biologically active agents. It is possible to shorten the raw material processing time by implementing new processing methods that allow of reducing consumption of resources for

candied fruit production and enhance the ready product quality.

**Problem statement**

Candied fruit product range in Ukrainian market is limited and presents, basically, the products made of fruit and berries. Besides, some of them contain artificial colouring agents that make it impossible to refer them to the healthy foods category. As prices of candied fruit are high, a wide circle of consumers cannot afford it. Therefore, production of such a dessert out of a non-traditional raw material that is cultivated in Ukraine make it possible to enhance the range of candied vegetables of domestic production. The existing techniques of cooking such products are

lasting and necessitate rigid processing modes; that is why it is desirable to apply such a processing technology for making ready products, which leads to preservation of nutrients.

**Review of literature**

Candied fruit mean those products that are made of fruit, vegetables and berries saturated with sugar and/or natural sweeteners added or not added with edible acids, flavours and colouring agents, dried, dusted with sugar powder or glazed [3].

Candied fruit are classified according to the used raw material, shape and method of use, and is shown in Fig.1.

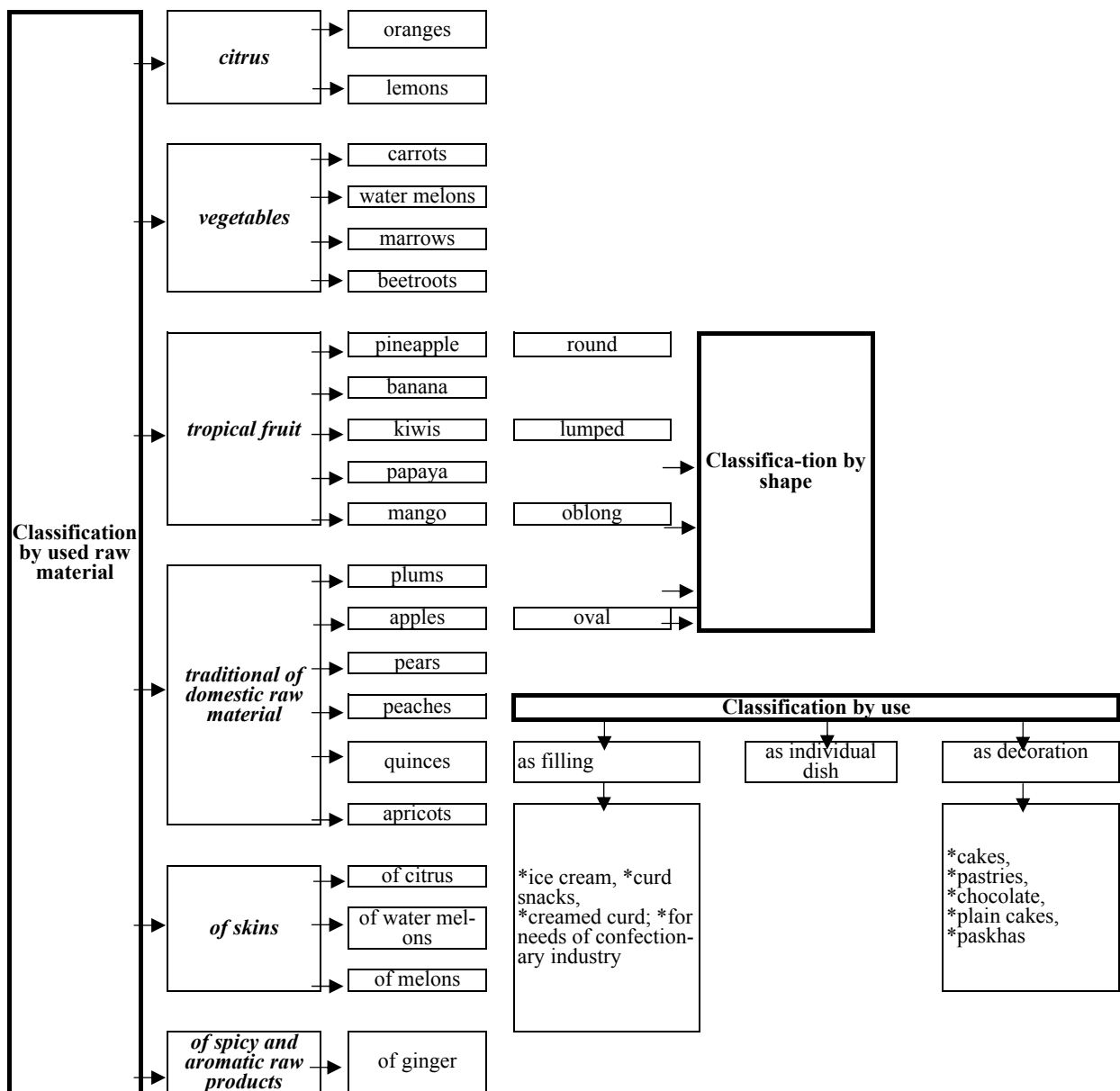

Fig. 1. Candied fruit classification

It is evident from Fig. 1 that the widest range of candied products comprises the traditional domestic

raw material, the most popular vegetable raw materials being watermelon, carrots, marrows and beetroots. The

use of these products is also diverse: they can be used as an individual dish or as fillers of various food products and for their decoration [4].

Fig. 2 describes the candied fruit market distribution in Ukraine by segments according to the used raw material.

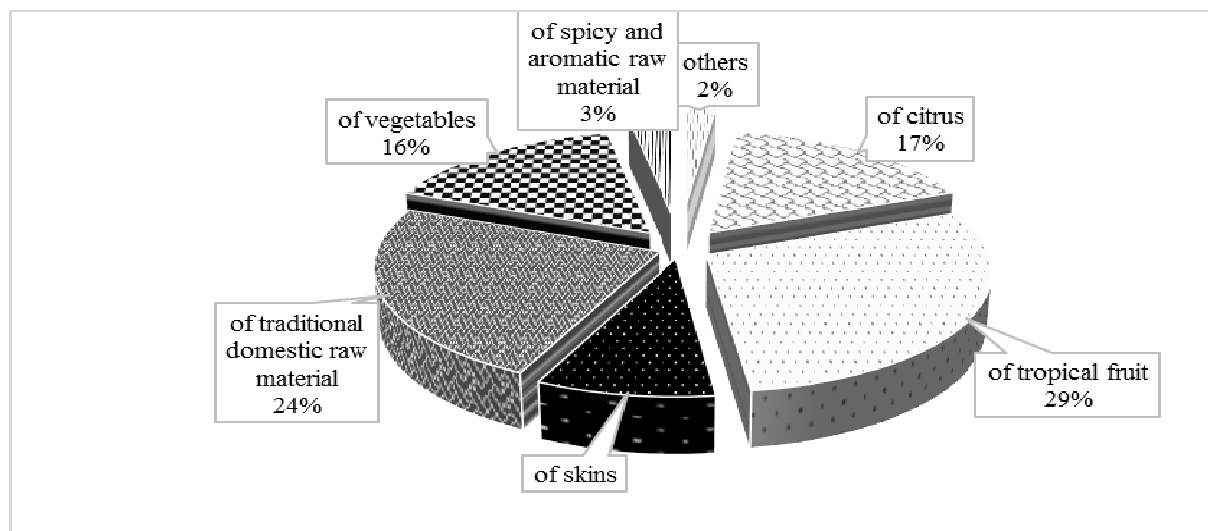

Fig. 2. Candied fruit market in Ukraine in 2015 – 2016

The diagram indicates that the share of candied vegetables comprises 16 % only. As distinct from candied fruit and berries, candied vegetables contain more fibres required for digestion. Such products contain proteins, carbohydrates, potassium, calcium, phosphorous, magnesium and vitamins A, C, B<sub>1</sub> and B<sub>2</sub>, PP.

Due to high concentration of sugar, candied fruit are well storable. The surface layer of the ready product prevents overdrying and spoilage by microorganisms. It also preserves the inner structure and the chemical composition of the product close to their initial condition [5].

Use of celery and parsnip roots makes it possible to produce candied fruit almost throughout the year beginning from October – it is particularly important that this raw material can be processed in winter [6].

The above described data preconditions topicality of development of the candied product technologies with the use of the non-traditional raw materials [7].

The method of making candied products [8] that includes preparation of fruit-and-vegetable raw material followed by boiling in a fruit or berry juice (with 70 % content of dry substances), separation of raw material from the liquid phase and drying is known. A drawback of this method is a long time required for boiling candied products in the concentrated fruit or berry juice for 4 hours. Preparation of such concentrated juices increases the ready product cost of the ready product while the lasting thermal treatment (boiling for about 4 hours) reduces the nutritional value of the product.

There exists also a method of candied beetroots production [9] that provides for washing roots and their thermal treatment with the aid of high-frequency heating at a specific power rating of 450 – 500 W/kg during 18 – 25 min. The processed roots are peeled and

cut into lumps, afterwards they are electrochemically activated in the anode zone of the activator until reaching pH 2.0 – 2.5 at water duty 1.0 – 1.5. Then the roots lumps are boiled in sugar syrup, separated from the syrup, dry a bit and powdered with sugar. The resulted candied vegetables are dried until their moisture content reaches 14 – 17 %.

Application of thermal treatment by high-frequency heating and electrochemical activation require additional equipment for the enterprise engaged in production of candied fruit which results in higher cost of the final products and lengthens the candied product preparation period, besides such candied products have low nutritional value.

As follows from the review of literary sources, the candied products made of non-traditional spicy and aromatic raw materials, except ginger candied products (Fig 2) are not present in the Ukrainian market and the known roots processing methods have a number of drawbacks.

#### Main part

This paper was aimed at developing a technology of candied white roots, namely, the celery and parsnip roots, which widens the range of such products that acquire original taste and high nutritional value.

The chemical composition of candied products depends both on the raw material used and on the production technology.

When processing white roots, namely, when making such mechanical operations as peeling, cutting and shredding the raw material becomes darker which influences considerably not only organoleptic properties of ready products but also leads to a loss of their nutritional value because of the redox enzyme action

which activity becomes higher in the presence of ambient oxygen.

Therefore, in order to reduce losses of nutritional substances and improve the organoleptic properties of dishes based on celery and parsnip roots, it is advisable to apply certain techniques aimed at inactivation of such enzymes as polyphenol oxidase, ascorbate oxidase and peroxidase [10].

To preclude darkening and stabilize colouring, a technology has been developed that provides for soaking whole roots in 1 % citric acid solution at once after peeling. To facilitate diffusion and osmotic processes as well as to soften the raw material before boiling in sugar syrup, steam cooking was applied which, in its turn, made it possible to preserve water-soluble vitamins and other biologically active agents.

The developed technology for producing candied celery and parsnip is shown in Fig. 3.

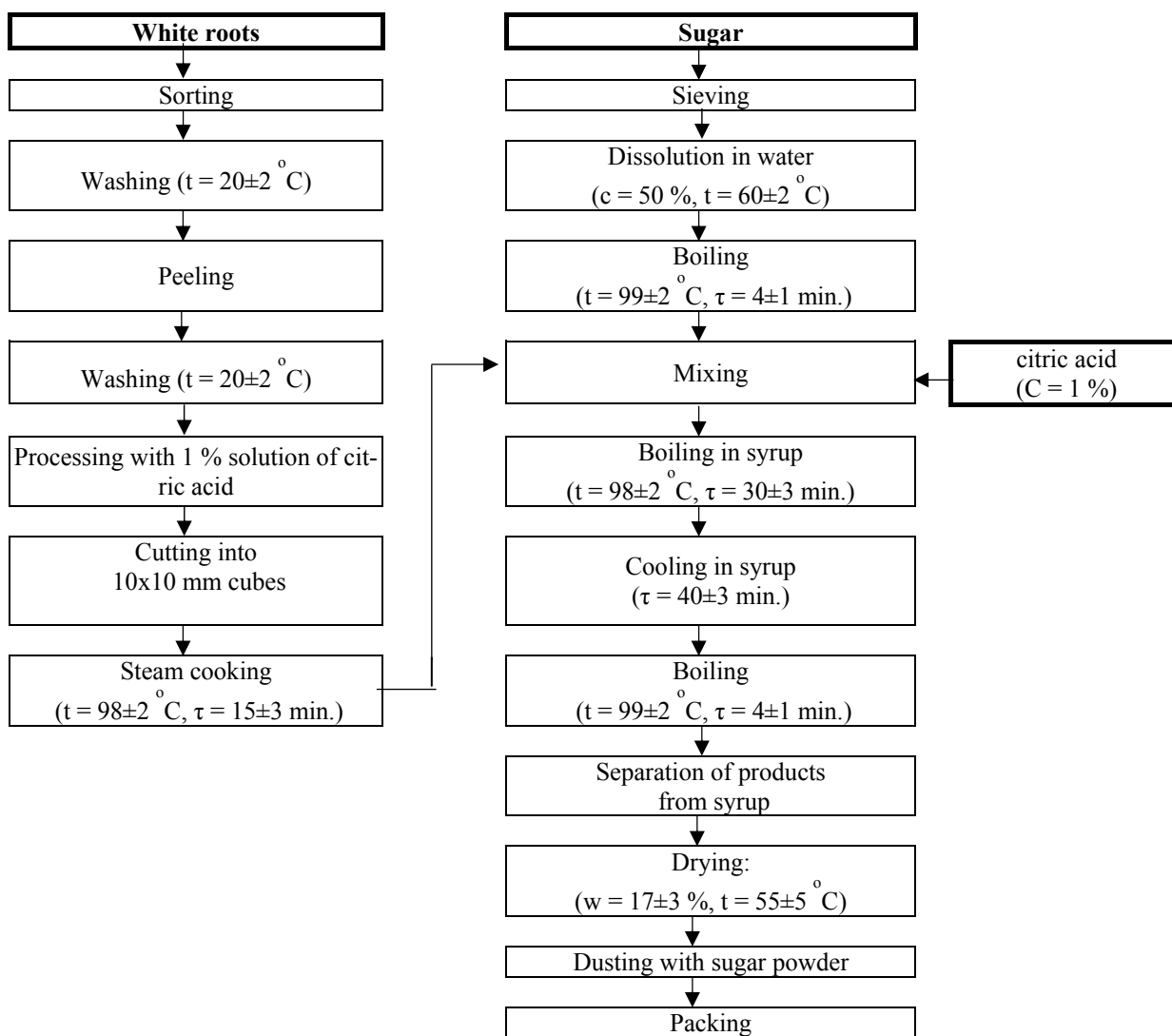

Fig. 3. Technology of making candied white roots

Concentrations of the citric acid solution and the sugar syrup have been established experimentally. Physical and chemical indicators of ready products have been determined and the organoleptic properties assessed.

Duration of the candied product technological cycle was analysed with the aid of the constructed Gantt diagram (Fig. 4).

These diagrams indicate a reduction of the candied white roots technological process by the developed technology due to shortening the boiling time to 30 min.

Analysis of the biochemical composition of candied celery and parsnip confirms their high nutritional value (Table 1).

The data supplied in Table 1 indicate that there is more vitamin C in candied celery, which is due to their initial content in the raw material. This vitamin is an indispensable component of the human ration, it is an antioxidant and a good restoring agent. On the contrary, there is more thiamin the candied parsnip. It is known that this water soluble vitamin participates in the carbohydrate, energy, protein and water-salt metabolism, and produces a regulatory action on the nerv-

ous system. Deficiency of thiamine in the organism leads to accumulation of lactic and pyroacemic acids in muscle tissue, it results in a disturbance of the acetyl-

choline synthesis and deterioration of the nervous, cardiovascular and digestive systems [11,12].

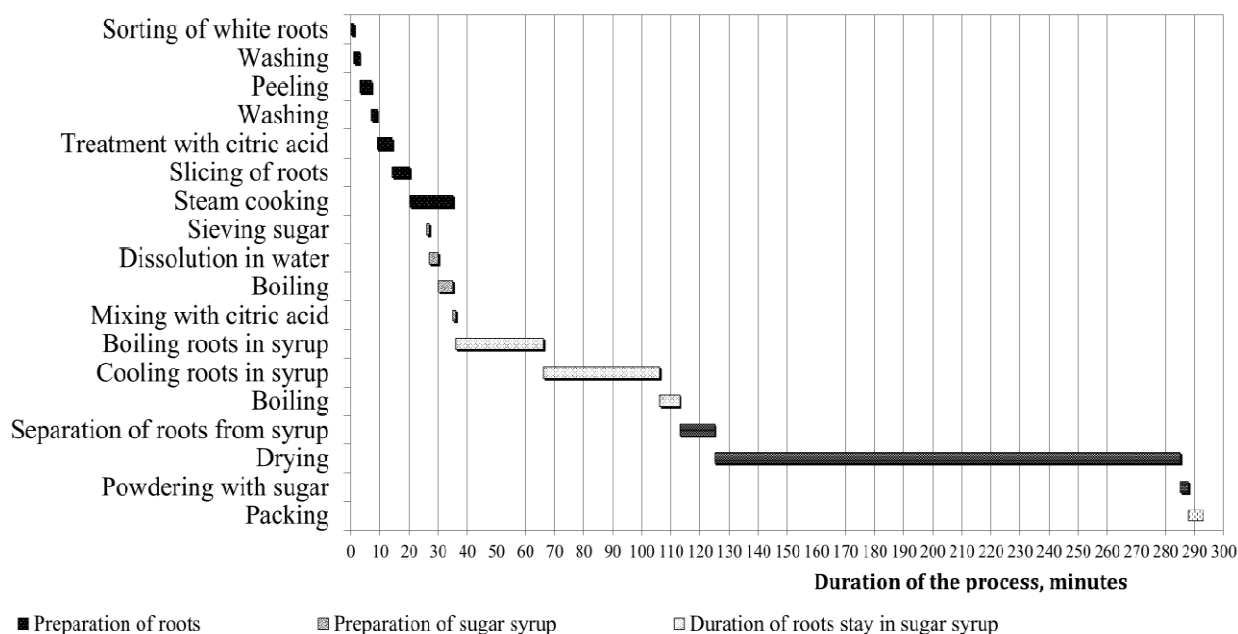

Fig. 4. Gantt diagram

Table 1 – Biochemical composition of candied white roots (as absolutely dry substance)

| Description of indicator                      | Candied parsnip | Candied celery |
|---|-----------------|----------------|
| Vitamin C, mg/100 g                           | 17.08           | 21.66          |
| Thiamin, mg/100 g                             | 1.480           | 0.050          |
| Phenol compounds, mg/100 g                    | 495.49          | 715.00         |
| Mass fraction of mineral substances, %, incl. | 0.810           | 1.360          |
| calcium                                       | 0.316           | 0.188          |
| magnesium                                     | 0.233           | 0.113          |
| iron  | 8.780           | 23.57          |
| potassium                                     | 0.080           | 0.220          |

Candied celery roots contain almost 1.5 times more phenol compounds than the candied parsnip roots. They play important part in metabolism and are of great practical significance. The majority of phenol compounds are antioxidants. Their antioxidant activity is due to two factors: phenol compounds fix heavy metal ions in stable complexes thereby depriving the latter of catalytic activity; they serve as acceptors of free radicals that are being formed at auto-oxidation. These substances participate in the oxide phosphorylation and influence activity of a number of important cell enzymes (including the digestive enzymes) and possess pronounced anticancer properties due to their antioxidant properties [13].

Among the studied mineral substances attention is drawn to the mass fraction of iron (there is 2.67 times more iron in the candied celery roots) which participates in blood formation, breathing, oxidation, redox reactions and immunobiological processes. Iron is

contained in blood and in more than one hundred of enzymes.

Organoleptic indicators of the developed candied products were studied: aroma, colour, appearance, taste and structure. The assessment was made according to 5-point scale [14-16]. The obtained results are shown in profilographs (Fig. 5).

According to organoleptic indicators the developed products are characterized as follows: appearance – cubes that are transparent at edges, not shrivelled, homogenous by size and shape, powdered with sugar powder and not sticking; consistence – dense, not dry, roots are uniformly boiled, easy to cut, no crystallized sugar crumbs; taste – pleasant odour with the spice and aromatic raw material flavour; colour – ranging from light to dark hot-yellow (with celery), and pink (with parsnip), all mass is homogenous, transparent at cutting; taste – sweet-sour with spicy smack.

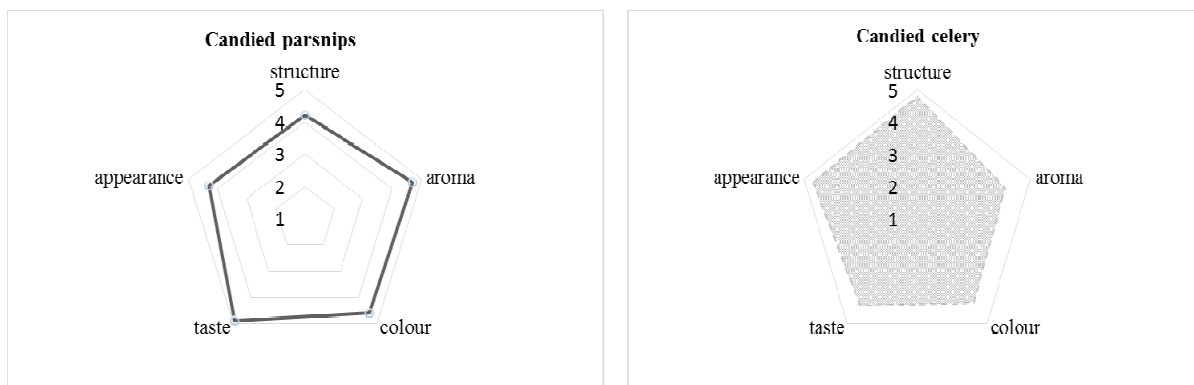

Fig. 5. Organoleptic assessment of candied products

Results of the analysis for microbiological indicators of products made at once after production and after 3 months storage are indicative of compliance

of the experimental specimen with the hygienic safety requirements. Results of the study are shown in Table 2.

Table 2 – Analysis of the microbiological indicators of ready candied products

| Description of the indicator                         | Candied celery              |                             | Candied parsnip             |                             | Standard value                |
|--|-----------------------------|-----------------------------|-----------------------------|-----------------------------|-------------------------------|
|  | after production            | after 3 month storage       | after production            | after 3 month storage       |                               |
| QMA&OAMO, CFU/g                                      | $(1.5 \pm 0.5) \times 10^2$ | $(6.0 \pm 1.0) \times 10^2$ | $(1.0 \pm 0.5) \times 10^2$ | $(5.0 \pm 1.0) \times 10^2$ | Not more than $5 \times 10^3$ |
| Escherichia coli-group bacteria (coli-forms), in 1 g | Not detected                | Not detected                | Not detected                | Not detected                | Not allowed in 1.0 g          |
| Pathogenic, including Salmonella, in 25.0 g          | Not detected                | Not detected                | Not detected                | Not detected                | Not allowed in 25.0 g         |
| Yeast, CFU/g   | Not detected                | Not detected                | Not detected                | Not detected                | Not more than 50              |
| Mold, CFU/g  | Not detected                | Not detected                | Not detected                | Not detected                | Not more than 50              |

After 3 months storage period candied celery and parsnip roots have no signs of mould and yeast, coli-group bacteria (coli-forms) and pathogenic organisms, including Salmonella-group bacteria [17].

The obtained experimental data confirms that the organoleptic, biochemical and microbiological indicators of candied celery and parsnip are stable throughout the storage period not exceeding 3 months at temperature ranging from 0 to 20 °C and at relative air humidity of 60 – 70 %.

**Application of the study results.** The proposed technology of candied celery and parsnip roots may be recommended for use in restaurants, both as an individual dish or as various desserts.

**References:**

- Gautam, K.H. Lapsi, fruit snacks. In: Riches of the forest: Food, spices, crafts and resins of Asia. Editors: C. López and P. Shanley. Center for International Forestry Research, Jakarta, Indonesia: 2004, – p. 9-12.
- Дудченко, Л.Г., Козьяков А.С., Кривенко В.В. Пряно-ароматические и пряно-вкусовые растения: Справочник [Текст] /Л.Г. Дудченко. – К.: Наук. думка, 1989. – 304 с.
- Сирохман, І.В., Задорожний І.М., Пономарьов П.Х. Товарознавство продовольчих товарів. 4-е видання. Підручник. [Текст] / Київ: Лібра, 2005. – 368 с.
- Kerr, L. H. The latest development in preservation of fruit crops [Text] / L. H. Kerr// Research and development department ministry of agriculture – Jamaica school of agriculture – 1980, – p.28-32.
- Ходак, А.П., Портнова Н.Н., Сухих Т.Н., Овчинникова Г.А., Песечник Л.А. Цукаты и их использование в производстве конфет / Обзор. Информ. Пищевая пром-сть. Сер. 17. Конд. пром-сть. - М.: АгроНИИТЭИПП, 1991. – Вып. 44. – 28 с.

**Conclusions**

Proposed is a developed technology for producing candied celery and parsnip roots according to the shortened processing cycle. The obtained products possess original organoleptic indicators and high nutritional value. The resulting candied products meet the requirements of standards according to microbiological indicators. New products will allow of extending the range of such products.

By the results of the study, the process flow documentation has been developed and an application for a utility model patent has been filed.

6. Judith, A. Fr., Fruit Crops Project The Fruit Industry in the Caribbean Production, Processing, Marketing & Future Prospects [Text] / A. Fr. Judith // COMUNICA/ Año 5 – N°16 – 2001 – p. 48-59.
7. Collins, R. Persimmon. In: The new rural industries. A handbook for farmers and investors. Editor: K.W. Hyde / RIRDC, Kingston. – 1998, – Australia: 302-305.
8. Горелова, Л.М.; Мальшева В.К.; Квасенков О.И. Пат. № 2092075 Російської Федерації на винахід А23L1/06. Способ производства цукатов [Текст] / Всероссийский научно-исследовательский институт консервной и овощесушильной промышленности № 95116459/13; Заявл. 19.09.1995; Оpubл. 10.10.1997.
9. Магомедов, Г.О., Бывальцев А.И., Семенов А.Л. Пат. № 2231268 див. патент Російської Федерації. Способ производства цукатов из сахарной свеклы [Текст] / Государственное образовательное учреждение Воронежская государственная технологическая академия № 2003104948/13; Заявл. 19.02.2003; Оpubл. 27.06.2004.
10. Біленька, І. Р. Оксидоредуктази білих коренів [Текст] / І.Р. Біленька, Я.А. Голінська // Науковий вісник Львівського національного університету ветеринарної медицини та біотехнологій імені С.З.Гжицького – 2015. – №4 (64) – Т.17 – стор.6-11.
11. Сирохман, І. В. Товарознавство харчових продуктів функціонального призначення: навч. пос. [Текст] /Л.В.Сирохман, В.М.Завгородня. – К.: Центр учбової літератури, 2009. – 544 с.
12. Тележенко, Л.Н. Биологически активные вещества фруктов и овощей и их сохранение при переработке [Текст] / Л.Н. Тележенко, А.Т. Безусов // – Одесса: Оптимус, 2004. – 268 с.
13. Fogliano, V. Method for measuring antioxidant activity and application to monitoring the antioxidant capacity of wines [Text] / V. Fogliano [et al] // J. Agric. Food Chem/ – 1999. – Vol. 47, No. 3. – P. 1035–1040.
14. Вольпер, И.М., Гри А.Н., Лазарев Е.Н. и др. Органолептические методы оценки продовольственных товаров [Текст] / И.М. Вольпер, А.Н. Гри, Е.Н. Лазарев - М.: Экономика, 1973.
15. Шепелев, А.Ф. Товароведение и экспертиза плодовоовощных товаров [Текст] / А.Ф. Шепелев, О.И. Кожухова. – Ростов н/Д, 2001. – 64 с. 2.
16. Цапалова, И. Э. Экспертиза продуктов переработки продуктов и овощей [Текст] / И.Э. Цапалова [и др.]. – Новосибирск: Сиб. унив. из-во, 2003. – 271 с.
17. Захаренко, В.О., Непочатих Т.А. Товарознавча оцінка якості нових цукатів з гарбуза та моркви // Матеріали міжнар. наук.-практ. конф. „Товарознавство та ринок споживчих товарів у 3-му тисячолітті”. – Донецьк: ДонДУЕТ, 2004. – С.24-25.

## ТЕХНОЛОГИЧЕСКИЕ АСПЕКТЫ ИЗГОТОВЛЕНИЯ ЦУКАТОВ ИЗ НЕТРАДИЦИОННОГО СЫРЬЯ

И.Р. Бельнская, к.т.н., доцент, E-mail: foodprofi@gmail.com

Я.А. Голинская, аспирант, E-mail: golinskaya.yana@mail.ru

\*Кафедра технологии ресторанного и оздоровительного питания

Одесская национальная академия пищевых технологий, ул. Канатная, 112, г. Одесса, Украина, 65039

**Аннотация.** В статье проведен анализ рынка цукатов в Украине, изложены основные технологические операции по переработке нетрадиционного для цукатов сырья – корней сельдерея и пастернака. Одной из проблем при технологической переработке белых корней является потемнение поверхности корнеплодов в связи с ферментативным окислением, что приводит к ухудшению товарного вида продукта. Для предупреждения потемнения по разработанной технологии предусмотрено замачивание сырья в 1 % растворе лимонной кислоты сразу после очистки. Для улучшения протекания диффузионно-осмотических процессов, а также размягчения корнеплодов перед увариванием в сахарном сиропе, применяют бланширование паром. Построена диаграмма Ганта, которая указывает, что разработанная технология позволяет сократить время приготовления цукатов. Изучены физико-химические свойства новых продуктов. Проведена экспертная оценка цукатов по органолептическим показателям. Установлено, что цукаты имеют надлежащие биохимические показатели и оригинальные органолептические свойства, в результате чего будут пользоваться спросом у потребителей. Результаты дегустационной оценки экспериментальных образцов подтвердили высокое качество продуктов.

**Ключевые слова:** корни сельдерея, пастернака, цукаты, технология, диаграмма Ганта, органолептические показатели.

### References:

1. Gautam KH. Lapsi, fruit snacks. In: Riches of the forest: Food, spices, crafts and resins of Asia. Editors: C. Lopez and P. Shanley. Center for International Forestry Research, Jakarta, Indonesia. 2004; 9-12.
2. Dudchenko LH, Kozyakov AS, Krivenko VV. Pryano-aromaticheskie i pryano-vkusovyye rasteniya: Spravochnik. – K.: Nauk. Dumka. 1989; 304s.
3. Sirokhan IV, Zadorozhnyi IM, Ponomarov PH. Tovaroznavstvo prodovolchikh tovariv. 4-e vidannya. Pidruchnik. Kiyv: Libra. 2005; 368.
4. Kerr LH. The latest development in preservation of fruit crops. Research and development department ministry of agriculture. Jamaica school of agriculture. 1980; 28-32.
5. Khodak AP, Portnova NN., Sukhikh TN, Ovchinnikova G.A, Piesiechnik LA. Tsukaty i ikh ispolzovaniie v proizvodstve konfet / Obzor. Inform. Pishchevaya prom-st. Ser. 17. Kond. prom-st. M.: AgroNITEIPP. 1991;44:28.
6. Judith AFr, Fruit Crops Project The Fruit Industry in the Caribbean Production, Processing, Marketing & Future Prospects /COMUNICA/. 2001; 16; 48-59.

7. Collins R, Persimmon. In: The new rural industries. A handbook for farmers and investors. Editor: K.W. Hyde / RIRDC, Kingston. 1998; Australia: 302-305.
8. Horelova LM, Malysheva VK, Kvasienkov OI. Pat. № 2092075 Rosiiskoi Fiedieratsii na vynakhid A23L1/06. Sposob proizvodstva tsukатов. Vserossiiskii nauchno-issledovatel'skii institut konservnoi i ovoshchesushilnoi promyshlennosti № 95116459/13; Zayavl. 19.09.1995; Opubl. 10.10.1997.
9. Mahomiedov GO, Byvaltsev AI, Siemienov AL. Pat. № 2231268 dyv. patent Rosiiskoi Federatsyi. Sposob proizvodstva tsukатов iz sakharnoi svekly. Gosudarstvennoe obrazovatel'noe uchrezhdeniie Voroniezhszkaya gosudarstviennaya tekhnologicheskaia akademiia № 2003104948/13; Zayavl. 19.02.2003; Opubl. 27.06.2004.
10. Bilenka I.R, Golinska YAA. Oksidoreduktazi bilikh koreniv. Naukovii visnyk Lvivskoho natsionalnoho universitetu veterinarnoi medicini ta biotekhnologii imeni S.Z.Gzhickogo. 2015; 4 (64).17: 6-11.
11. Sirohman IV. Tovaroznavstvo kharchovikh produktiv funktsionalnogo pryznachennya: navch. pos. [Tekst] /I.V.Sirohman, V.M.Zavgorodnya. K.: Centr uchbovoi literaturi. 2009; 544.
12. Tieliuzhenko LN, Bieuzov AT. Biologichieski aktivnyie vieshchestva fruktov i ovoshchei i ikh sokhraneniie pri pierierabotkie. Odessa: Optimus, 2004; 268.
13. Fogliano V. Method for measuring antioxidant activity and application to monitoring the antioxidant capacity of wines. J. Agric. Food Chem. 1999; 47. 3: 1035–1040.
14. Volper IM, Gri AN, Lazarev EN i dr. Organolepticheskie metody ocenki prodovolstvennykh tovarov. M.: Ekonomika. 1973.
15. Shepelev AF. Tovarovedenie i ehkspertiza plodovoovoshchnykh tovarov. Rostov n/D, 2001. – 64
16. Sapalova IEN. Ekspertiza produktov pererabotki produktov i ovoshchei. Novosibirsk: Sib. univ. iz-vo, 2003; 271.
17. Zakharenko VO, Nepochatikh TA. Tovaroznavcha otsinka yakosti novikh tsukativ z garbuza ta morkvy. Materiali mizhnar. nauk.-prakt. konf. „Tovaroznavstvo ta rynek spozhivchih tovariv u 3-mu tisyacholitti”. Donetsk: DonDUET. 2004; 24-25.

Отримано в редакцію 19.03.2016

Прийнято до друку 16.05.2016