

UDC 338(47+57):316.422.44.

HIGH-TECH PROCESSING OF SECONDARY RESOURCES OF WINEMAKING

G. Kasyanov, Doctor of Sciences (Dr. Hab.) in Engineering, Professor, E-mail: Kasyanov@kubstu.ru
Department of technology of animal origin food products

T. Davydenko, Assistant Professor

Department of English

Kuban State Technological University, Moscovskaya str., 2, Krasnodar, Russia

Abstract. The information about problems and prospects of development of food production processes based on high-tech and knowledge-intensive technical solutions is presented. To accomplish these objectives the problems of rational growing of grapes, intensive methods of production of conventional and concentrated grape juice, application of CO₂ dextration for the removal of wine stone were solved.

White and red table grapes, grape pomace, grape seed oil, protein and CO₂-meal are the objects of the research. To evaluate the quality of raw materials, intermediate and finished products such devices as gas-liquid and thin-layer chromatography, and spectrophotometer were used. Obtaining of grape juice of white and red grapes with content of tartaric acid salts less than 1 %, food drying products and products of processing of grape pomace are the intermediate results of the research. Grape juice in flexible packages of «Pure-Pak» and «Doy-pack» types, CO₂-extracts of seeds and skins of grapes and protein CO₂-meal are the final objects of the research. Performed research allows us to make conclusions about expediency of high-tech methods of processing of raw materials for obtaining food products.

Key words: grapes, grape pomace, cream of tartar, CO₂-extract, grape juice.

ШЛЯХИ ПЕРЕРОБКИ ВТОРИННИХ РЕСУРСІВ ВИНОРОБСТВА

Г.І. Касьянов, доктор технічних наук, професор, E-mail: Kasyanov@kubstu.ru
Кафедра технології продуктів харчування тваринного походження

Т.М. Давиденко, доцент кафедри англійської мови

Кубанський державний технологічний університет, Московська вул., 2, Краснодар, Росія

Анотація. Представлено інформацію щодо проблеми та перспективи розвитку процесів виробництва продуктів харчування на основі високотехнологічних і наукомістких технічних рішень. Розглянуто питання раціонального вирощування винограду, інтенсивні способи отримання звичайного і концентрованого виноградного соку, застосування способів CO₂-детартрації для видалення винного каменю.

Об'єктами дослідження слугували білий і червоний виноград столових сортів, виноградні вичавки, виноградна олія, білковий CO₂-шрот. Для оцінки якісного складу сировини, напівпродуктів і готової продукції використовували методи газоріднинної та тонкошарової хроматографії, спектрофотометр. Проміжним результатом досліджень було отримання виноградного соку з білого і червоного винограду з вмістом солей винної кислоти менше 1 %, а також продуктів сушіння та переробки виноградної вичавки. Кінцевий результат досліджень – розфасований у гнучкі пакети типу «Пюр-Пако», «Дой-Пак» виноградний сік, CO₂-екстракти з насіння і шкірки винограду і білковий CO₂-шрот. Виконані дослідження дозволяють зробити висновки про доцільність використання високотехнологічних способів переробки сировини для отримання затребуваних продуктів харчування.

Ключові слова: виноград, вичавки, винний камінь, CO₂-екстракт, виноградний сік.

Copyright © 2015 by author and the journal "Food Science and Technology".

This work is licensed under the Creative Commons Attribution International License (CC BY) <http://creativecommons.org/licenses/by/4.0>



DOI: <http://dx.doi.org/10.15673/fst.v11i1.302>

Introduction

After processing of grapes for juice or wine 35 to 40 % of pomace remain, which are not utilized practically. However, during rational processing of grape pomace valuable substances for enrichment of yogurt and biodiesel production can be obtained [1]. The use of classical approaches for derivatization of fatty acids and phenols contained in the products of processing of grapes is described [2]. The choice of solvent affects the degree of extraction of polyphenols from grape seeds [3,4]. A number of foreign publications is devoted to the extraction of antioxidants and organic acids from grape skins and seeds, and their use in other industries [5-7]. In the work of M. Bravi, and others the description of method

of supercritical CO₂ extraction of oil and tocopherol from the seeds of grapes is given [8]. The process of extraction of components was carried out at the pressure of 25 MPa and at the temperature from 40 to 80 °C (313 –353 K). In Russia, a similar process is carried out at subcritical CO₂ extraction at the temperature of 20 – 22 °C (293 –295 K) and at the pressure up to 7 MPa, and it allows to preserve biological active substances of initial raw materials [9]. Catechin, epicatechin, quercetin, rutin and resveratrol are found in the skin of red grapes [10]. Information about antimicrobial properties of the extract from seeds of grapes is available [11].

Innovative research activity, confirming the need to develop new specialized products with social health value grows rapidly in Russian food market. High-tech

and innovative production processes of products made of fruit raw materials start with their cultivation and finish with packaging and storage of finished products. Under conditions of direct and retaliatory sanctions with European countries, special attention of progressive leaders of agricultural companies and farms was paid to cultivation of environmentally clean products made of raw materials of domestic breeding. The experience of Anapa agricultural firms that grow grapes using organic farming technologies is extremely significant. This technology is based on nearly complete absence of traditional fertilizers and crop protection chemicals instead of which organic fertilizers and biological methods of plant protection were used. Low-waste and non-waste processing methods of plant raw materials allow to receive dietary fiber, vegetable oils, extracts, dyes and organic acids in addition to main products. Microwave drying, processing of raw materials with electromagnetic field of low frequency, the extraction of valuable substances from plant matrix with fluid liquefied gases relate to high-tech and innovative processing of agricultural raw materials. It is suggested to use flexible packaging such as «Pure-Pak», «Doy-Pack» and others on the basis of food polymers which are biodegradable in soil.

The purpose of research is to carry out the analysis of ways of development of high-tech-intensive enterprises for processing of secondary resources of wine-making, taking into account the world market trend of biologically-active-products and the development of primary actions in the creation of effective levers of development of processing industries. The objectives of the study are development of highly effective and breakthrough technology for production of valuable components of grape pomace.

Statement of base material with presentation of scientific results

It should be noted that the state of branches of processing industry of agricultural raw materials is positive in general. The Russian food market is very attractive for foreign companies. The important task is to create innovative products from recycled plant material allowing to improve the efficiency and profitability of production significantly. White and red grapes, grape pomace, seeds and peels of grapes are the objects of this research. Table 1 shows the grapes selected for study.

Table 1 – Comparative characteristics of grape varieties selected for the study

Grade	Description	Disadvantages	Frost-resistance	Advantages
GiftMagaracha	Ripeningtime medium-late	Insufficient pollination	Grade does not require shelter for winter	Stability to mildew
Negro	Ripeningtime medium-late	Cracking	Grade does not require shelter for winter	Stability to mildew
VegaZaporozhskaya	Ripeningtime - medium	Cracking	Grade requires shelter for winter.	«one-size» of berries
Viking	Ripeningtime - medium	goroshatsa	Grade requires shelter for winter	not goroshatsa

The instruments of the Center of collective use of Food and Processing Industry Institute of KubSTU were used for research. Particle size analysis was performed using the principle of dynamic light scattering of the instrument Zetasizer Nano S. The melting temperature of crystals inside capillaries was determined using Stuart® device (England) in the temperature range of 20 – 400 °C. The viscosity of food products was assessed with rotary viscometer LV DV-II+Pro of the American firm «Brookfield» with a measuring range of 15 000 to 6000 cps (mPas). The measurement of the color characteristics of extracts, β -carotene content and chlorophyll were determined with colorimeter Lovibond (PFX995) of English firm «Tintometer Ltd» in a spectral range of 420-710 nm. The determination of metal content in raw materials and products was investigated with domestic atomic absorbing spectrometer (A-2) in a spectral range of 190-900 nm. The vitamins B, C and toxic elements As, Cd, Hg, Pb, Zn were determined with voltammetric analysis instrument (STA – 1) in the range of ions of 0.001 – 1.0 mg/dm³.

The analysis of the content of phenolic compounds and metals in food products was measured with UV-spectrophotometric method in a measuring range of 190 – 1100 nm. The fatty acid composition of fat-containing substances was determined with GLC-method by the domestic chromatograph («Chromatec Crystal 5000»). The chemical composition of organic and inorganic components was determined using a gas chromatograph (LR-2ST) of IKA company (Germany). The emulsification was measured in a special reactor (LR-2ST) of IKA company (Germany).

Organic and inorganic compounds were determined by IR spectrometer with Fourier transformation by the instrument Perkin Elmer (UK) in a range of 350 – 8000 cm⁻¹. An electronic library of spectra for comparison of composition of samples with the standard is included into the structure of instrument system.

Depicted in Figure 1 setting allows us to separate grape seeds and peel from husks. About 40 % of secondary resources of juice and wine production, once considered to be wastes, appear during processing of grapes. Grape berries contain from 6 to 10 % of skin, from 87 to

91 % of pulp, from 2 to 5 % of seeds depending on the variety and place of growing. Marc forms from 20 to 23 % of processed grapes. Juice pomace contains up to 25 % of seeds, 50 % of berries and 25 % of skin stems after squeezing.

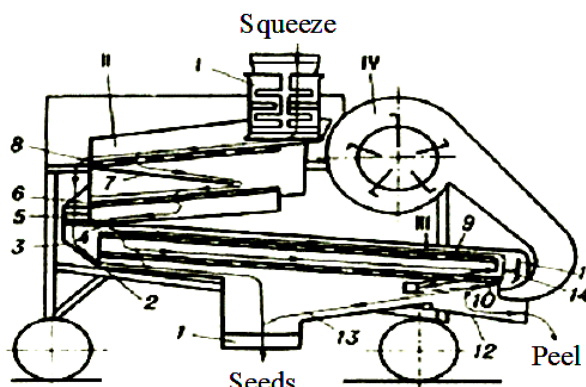

I – charging device, II – unit with perforated tape, III – mesh conveyor, IV – fan. 6, 8, 9, 10 – sieve; 1, 3, 5, 11, 12, 14 – runways; 2, 4, 7, 13 – Dona pitched
Figure 1 - Installation for separation of seeds from grape marc.

A considerable amount of research on the processing of grape seeds for food and feed purposes is

made at the Department of fat technology of KubSTU involving Azarov Y.I., Dudarev M.S., Kalmanovich S.A., Kornena E.P., Martovschuk V.I., Mgebrishvily T.V. and Pershakova T.V. An advanced technology of wine production, powder from pomace of grapes are presented in the work of Sidorenko A.V.

Figure 2 shows a production line allowing to recycle CO₂-extracts of seeds and skin of grapes.

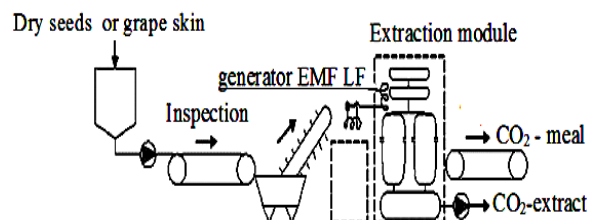

Fig. 2. Experimental line for extraction of valuable components from seeds and skins of grapes

The difference between the line shown in Figure 2 and the technological line which was well-known earlier is the possibility to intensify the process of CO₂-extraction with EMI bass. Table 2 shows the content fatty acid in oil of grape seeds.

Table 2 – Mass fraction of fatty acids in a CO₂-extract of grape seeds

Fattyacid	Gift Magaracha	Negro	Vega Zaporozhskaya	Viking
Myristic	0,07	0,04	0,03	0,05
Palmitic	10,07	7,81	7,55	7,48
Palmitoleic	0,20	0,19	0,12	0,07
Stearic	3,38	3,22	3,13	3,39
Oleic	20,67	19,8	17,46	18,1
Linoleic	64,63	68,09	70,87	69,8
Linolenic	0,52	0,43	0,41	0,45
Arachidic	0,19	0,13	0,13	0,18
Eicosenic	0,14	0,17	0,22	0,18
Behenic	0,04	0,03	0,02	0,06
Erucic	0,01	-	0,01	
Lignocaine	0,08	0,09	0,06	0,23

As it can be seen from Table 2, in CO₂-extract of grape seeds there is a set of nonessential and essential fatty acids. Table 3 shows the evaluation of antioxidant and antiradical properties of extracts of seeds and skin of grapes.

Table 3 –The comparative evaluation of antioxidant and antiradical properties of extracts of seeds and skin of grape berries Viking

Objectsof research	Phenols mg/100 g	Flavonoids, mg/100 g	β-carotene, mg/100g	Antiradical activity, mg/sm ³	Antioxidantactivity, % of inhibition
CO ₂ -extract of grape seeds	250,0±4,3	82,0±1,5	4,9±0,05	96,0±0,9	65,4±1,3
CO ₂ -extract of grape peel	390,0±5,5	86,0±1,5	1,3±0,06	128,0±0,4	72,6±1,8
Alcohol extract of skin of grape berries	225,0±3,5	94,0±1,6	1,1±0,05	88,0±0,5	52,4±1,2

Due to the high content of essential substances CO₂-extracts can be considered to be natural antioxidants. Mass composition of amino acids in CO₂ grist of grape seeds after removal of CO₂ extractives is given in Figure 3.

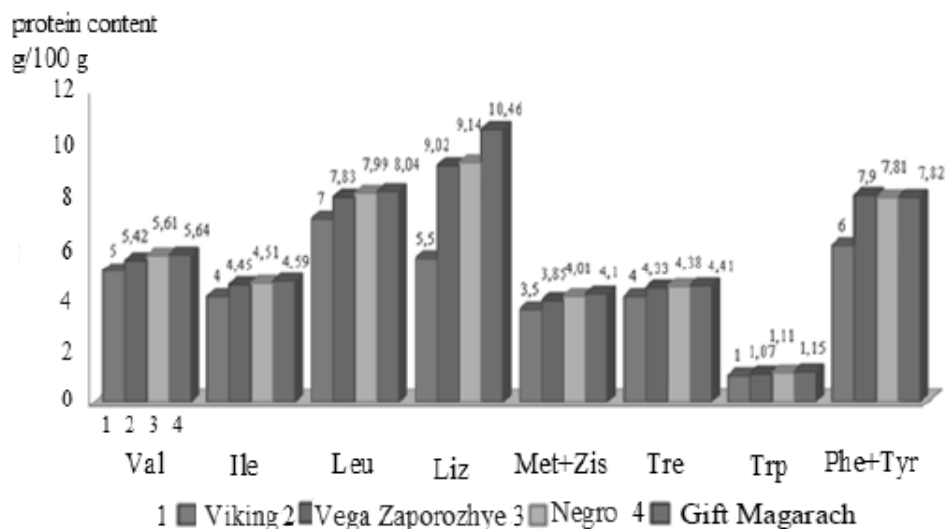

Fig. 3. Mass composition of amino acid in CO₂ grist of grape seeds after removal of CO₂ extractives.

Due to mass composition of amino acid in CO₂-extracted meal of grape seeds, it can be used to enrich a wide group of food products as a protein filler.

Findings of research results and prospects for further investigations in this area

The scientific study of the analysis of chemical composition of grape pomace of four varieties (Vega Zaporozhskaya, Viking, Negro and Gift Magaracha) was carried out under author's supervision. The necessity and expediency of improving the methods of separation of grape pomace in seeds and skin in order to obtain food additives were proved.

The chemical composition of pomace, grape seeds and skin was determined with the participation of

the applicant Tagirova P.R. It was found by experiment that the protein content in seeds of Magaracha Pervenets and Negro varieties is 37 – 38 %, oil content – 8.5 – 9 %. High content of valuable components in grapes grown in a foothill zone was determined: 1 % of protein, 0.9 % of lipids and 1.1 % of nitrogen-free extractives. The technological methods of producing CO₂-extracts from seeds and skin of grape varieties Pervenets Magaracha and Negro with the frequency of fluctuations of the solvent to 30 cm⁻¹, affected by a low-frequency EMF in the range of 18 – 38 Hz.

It is planned to continue the research of rational use of winemaking resources. It is planned to perform works on food enriching with grape oil, protein meal and extracts from seeds and skins of grapes.

References:

- Zorana Andonovic Application of Grape Pomace as a Natural Food Preservative and Source of Biofuel / Zorana Andonovic, Dusko Nedelkovski, Krste Tasev, Klime Beleski // Food Technology.– 2014. – P. 54.
- Tasev Krste Optimization and validation of a derivatization method for analysis of biogenic amines in wines using RP-HPLC-DAD / Tasev Krste and Ivanov, Violeta and Stefova Marina //Macedonian Journal of Chemistry and Chemical Engineering.– 2016.– № 35 (1).– P. 19–28.
- Tataridis P. Papakonstantinou. Utilization of grape pomace for the production of bacterial cellulose / P. Tataridis, K. Apostolopoulos, E. Moraitaki, D. Spanou, E.T. Nerantzis, S. Pan-Hellenic // Union of Bioscientists Congress “Biosciences in the 21century”, 13-15 April. – 2006.– Athens, Greece, pp. 114.
- Yilmaz Y. Oxygen radical absorbance capacities of grape/wine industry byproducts and effect of solvent type on extraction of grape seed polyphenols / Y. Yilmaz, R.T. Toledo // Journal of Food Composition and Analysis. –2006.– № 19.– P. 41–48.
- Andonovic Zorana and Ivanova Violeta and Nedelkovski Dusko and Tasev Krste and Beleski Klime. Production of a new dairy product enriched with antioxidants from grape pomace and berries. In: XXIII Congress of Chemists and Technologists of Macedonia, 8-11 Oct 2014, Ohrid, Macedonia.
- Tasev Krste and Ivanova Violeta and Stefova Marina. Determination of main organic acids in Macedonian wines by RP HPLC. In: 24th International Scientific-Expert Conference of Agriculture and Food Industry – Sarajevo, 25–28 Sept 2013, Sarajevo, Bosnia and Hercegovina.
- Xu C. Phenolic compounds and antioxidant properties of different grape cultivars grown in China / Xu C., Zhang Y., Cao L., Liu J. // Food Chemistry.– 2010.– № 119 (4).– P.1557–565.
- Bravi M., Spinoglio F., Verdona N. Extraction of oil enriched in α -tocopherol from grape seeds (*Vitisvinifera*) using supercritical carbon dioxide // Dipartimento di IngegneriaChimica – Università di Roma “La Sapienza” Via Eudossiana, 18 – 00184 Roma, Italy.
- Tagirova P.R. Processing of pomace and grape seeds using liquid carbon dioxide /P.R. Tagirova, D.G. Kasyanov // Proceedings of the universities. Food technology – 2010. – №2-3. – P. 60–62.
- Iacopini P. Catechin, epicatechin, quercetin, rutin and resveratrol in red grape: Content, in vitro antioxidant activity and interactions / P. Iacopini, M. Baldi, P. Storchi, L. Sebastiani // Journal of Food Composition and Analysis 21.–2008.– № 8.– P. 589–598.
- Furiga A. In vitro study of antioxidant capacity and antibacterial activity on oral anaerobes of a grape seed extract. Furiga A., Lonvaud-Funel A., Badet C Food Chemistry.– 2009.– № 113 (4).– P.1037–1040.

ПУТИ ПЕРЕРАБОТКИ ВТОРИЧНЫХ РЕСУРСОВ ВИНОДЕЛИЯ

Г.И. Касьянов, доктор технических наук, профессор, E-mail: Kasyanov@kubstu.ru
кафедра технологии продуктов питания животного происхождения

Т.М. Давыденко, доцент
кафедра английского языка

Кубанский государственный технологический университет, Московская ул., 2, Краснодар, Россия

Аннотация. Представлена информация о проблемах и перспективах развития процессов производства продуктов питания на основе высокотехнологичных и наукоемких технических решений. Для выполнения поставленной цели решались задачи рационального выращивания винограда, интенсивные способы получения обычного и концентрированного виноградного сока. Применение способов CO₂-детартрации для удаления винного камня.

Объектам исследования служили белый и красный виноград столовых сортов, виноградные выжимки, виноградное масло, белковый CO₂-шрот. Для оценки качественного состава сырья, полупродуктов и готовой продукции использовали приборы газожидкостной и тонкослойной хроматографии, спектрофотометр. Промежуточными результатами исследований является получение виноградного сока из белого и красного винограда с содержанием солей винной кислоты менее 1 %, продукты сушки и переработки виноградной выжимки. К конечным объектам исследований относится расфасованный в гибкие пакеты типа «Пюр-Пак», «Дой-Пак» виноградный сок, CO₂-экстракты из семян и кожицы винограда и белковый CO₂-шрот. Выполненные исследования позволяют сделать выводы о целесообразности использования высокотехнологичных способов переработки сырья для получения востребованных продуктов питания.

Ключевые слова: виноград, выжимки, винный камень, CO₂-экстракт, виноградный сок

References:

1. Zorana Andonovic, Dusko Nedelkovski, Krste Tasev, Klime Beleski Application of Grape Pomace as a Natural Food Preservative and Source of Biofuel. Food Technology. 2014; 54
2. Tasev Krste and Ivanova Violeta and Stefova Marina Optimization and validation of a derivatization method for analysis of biogenic amines in wines using RP-HPLC-DAD. Macedonian Journal of Chemistry and Chemical Engineering. 2016; 35 (1):19-28.
3. Tataridis P, Apostolopoulos K, Moraitaki E, Spanou D, Nerantzis ET, Pan-Hellenic S. Papakonstantinou. Utilization of grape pomace for the production of bacterial cellulose. Union of Bioscientists Congress "Biosciences in the 21century", 13-15 April, Athens, Greece. 2006; 114.
4. Yilmaz Y, Toledo RT. Oxygen radical absorbance capacities of grape/wine industry byproducts and effect of solvent type on extraction of grape seed polyphenols, Journal of Food Composition and Analysis. 2006; 19: 41–48.
5. Andonovic Zorana and Ivanova Violeta and Nedelkovski Dusko and Tasev Krste and Beleski Klime. Production of a new diary product enriched with antioxidants from grape pomace and berries. In: XXIII Congress of Chemists and Technologists of Macedonia, 8-11 Oct 2014.
6. Tasev Krste and Ivanova Violeta and Stefova Marina. Determination of main organic acids in Macedonian wines by RP HPLC. In: 24th International Scientific-Expert Conference of Agriculture and Food Industry. Sarajevo, 25–28 Sept 2013.
7. Xu C, Zhang Y, Cao L, Liu J. Phenolic compounds and antioxidant properties of different grape cultivars grown in China. Food Chemistry. 2010; 119 (4); 1557-1565.
8. Bravi M, Spinoglio F, Verdone N. Extraction of oil enriched in α -tocopherol from grape seeds (*Vitisvinifera*) using supercritical carbon dioxide. Dipartimento di IngegneriaChimica – Università di Roma "La Sapienza" Via Eudossiana. 18 - 00184 Roma, Italy.
9. Tagirova PR, Kasyanov DG. Processing of pomace and grape seeds using liquid carbon dioxide /P.R. Tagirova, // Proceedings of the universities. Food technology. 2010; 2-3: 60-62.
10. Iacopini P, Baldi M, Storchi P, Sebastiani L. Catechin, epicatechin, quercetin, rutin and resveratrol in red grape: Content, in vitro antioxidant activity and interactions. Journal of Food Composition and Analysis 21. 2008; 8; 589-598.
11. Furiga A, Lonvaud-Funel A, Badet C. In vitro study of antioxidant capacity and antibacterial activity on oral anaerobes of a grape seed extract. Food Chemistry. 2009; 113 (4): 1037-1040

Отримано в редакцію 22.12.2016
Прийнято до друку 20.01. 2017

Received 22.12.2016
Approved 20.01. 2017

UDC [637.04:615.322:663.81]:519.85

MODELLING FORMULAE OF STRAWBERRY WHEY DRINKS OF PROPHYLACTIC APPLICATION

N. Tkachenko, Doctor of Sciences (Dr. Hab.) in Engineering, Professor*, *Email: nataliya.n-2013@yandex.ua*

P. Nekrasov, Doctor of Sciences (Dr. Hab.) in Engineering, Professor**, *Email: nekrasov2007@gmail.com*

S. Vikul, Candidate of Technical Sciences, Assistant Professor***, *Email: vizaj_vik@mail.ru*

Ya. Honcharuk, the Undergraduate of Department*, *Email: zagray.yana.95@mail.ru*

* Department of dairy technology and technology of fats and perfume-cosmetic products,

*** Department of Food Chemistry

Odessa national academy of food technologies, Kanatna str., 112, Odessa, Ukraine, 65039

** Department of Technology of fats and fermentation products

National Technical University «Kharkiv Polytechnic Institute», Kyrpychov str., 2, Kharkiv, Ukraine, 61002

Abstract. Expediency of the development of formulae and innovative technologies for production of prophylactic application drinks possessing antioxidant, probiotic and hepatoprotective properties with the use of the secondary dairy product – whey, as well as the domestic vegetable raw materials having a high content of bioactive substances has been substantiated.

Formulation composition of the prophylactic drinks based on cheese whey, extract of *Tagetes patula* flowers and the berry filler “Strawberry” with the use of the response surface method has been developed. Bioactivity of the drinks and the complex quality indicator which accounts for the total influence of the bioactivity, organoleptic assessment and weight coefficients of the specified unit indicators were taken as the optimization criteria; as the independent factors that were varied in the course of the experiment, the mass fractions of the marigold flowers extract and the strawberries filler were selected. It is recommended that the mass fractions of the berry filler “Strawberry” and the extract of *Tagetes patula* flowers in the prophylactic drinks are set as 7 and 20 % of the finished product, accordingly. The practical mass fraction of the citric acid of 0.2 % was determined as it ensures high organoleptic characteristics of the finished drinks. Recommendations are given concerning development of innovative technologies of unfermented and fermented strawberry whey drinks of prophylactic application enriched with the extract of *Tagetes patula* flowers.

Key words: whey, strawberry filler, *Tagetes*, bioactivity, organoleptic assessment, complex quality index, optimization, response surface.

МОДЕЛЮВАННЯ РЕЦЕПТУР СИРОВАТКОВО-ПОЛУНИЧНИХ НАПОЇВ ПРОФІЛАКТИЧНОГО ПРИЗНАЧЕННЯ

Н. А. Ткаченко, доктор технічних наук, професор, завідувач кафедри **Email: nataliya.n-2013@yandex.ua*

П. О. Некрасов, доктор технічних наук, професор, професор кафедри ***Email: nekrasov2007@gmail.com*

С. І. Вікуль, кандидат технічних наук, доцент, доцент кафедри ****Email: vizaj_vik@mail.ru*

Я. А. Гончарук, магістрант кафедри **Email: zagray.yana.95@mail.ru*

* кафедра технології молока, жирів і парфумерно-косметичних засобів

*** кафедра харчової хімії

Одеська національна академія харчових технологій, м. Одеса, вул. Канатна, 112, 65039

** кафедра технології жирів та продуктів бродіння

Національний технічний університет «Харківський політехнічний інститут», м. Харків, вул. Кирпичова, 2, 61002

Анотація. Обґрунтовано доцільність розроблення рецептур та інноваційних технологій напоїв профілактичного призначення з антиоксидантними, пробіотичними та гепатопротекторними властивостями з використанням вторинної молочної сировини – сироватки, а також вітчизняної сировини рослинного походження з високим вмістом біологічно активних речовин.

Розроблено рецептурний склад напоїв профілактичного призначення на основі сирної сироватки, екстракту квітів *Tagetes patula* і ягідного наповнювача «Полуниця» з використанням методології поверхні відгуку. У якості критеріїв оптимізації обрано біологічну активність напоїв і комплексний показник якості, який враховує сукупний вплив біологічної активності, органолептичної оцінки і коефіцієнтів вагомості зазначених одиничних показників; незалежними факторами, які варіювалися, в експерименті – масові частки екстракту квітів чорнобривців і полуничного наповнювача. Рекомендовано масову частку ягідного наповнювача «Полуниця» та екстракту квітів *Tagetes patula* в напоях профілактичного призначення встановити 7 і 20 % від маси готового продукту відповідно. Визначено раціональну масову частку лимонної кислоти – 0,2 %, яка забезпечує високі органолептичні характеристики готових напоїв. Наведено рекомендації з розробки інноваційних технологій неферментованих і ферментованих сироватково-полуничних напоїв профілактичного призначення, збагачених екстрактом квітів *Tagetes patula*.

Ключові слова: сироватка, полуничний наповнювач, *Tagetes*, біологічна активність, органолептична оцінка, комплексний показник якості, оптимізація, поверхня відгуку.

Copyright © 2015 by author and the journal “Food Science and Technology”.

This work is licensed under the Creative Commons Attribution International License (CC BY) <http://creativecommons.org/licenses/by/4.0>



DOI: <http://dx.doi.org/10.15673/fst.v11i1.303>