

УДК 514.18

Башта О.Т., Джурик О.В., Джурик Н.О.

Національний авіаційний університет

METHODICAL PROVISION OF TEACHING GRAPHICAL DISCIPLINES IN ENGLISH- SPEAKING PROJECT OF NAU

Bashta O.T., Dzhuryk O.V., Dzhuryk N.O. Methodical provision of teaching graphical disciplines in English-speaking project of NAU. Methodical elaborations used during studying process of graphical disciplines in English are considered.

Keywords: methodical elaboration, higher school, English language, graphical discipline.

Башта О.Т., Джурик О.В., Джурик Н.О. Методичне забезпечення викладання графічних дисциплін в англomовному проекті НАУ. Розглядаються методичні розробки, які використовуються в навчальному процесі при викладанні графічних дисциплін англійською мовою.

Ключові слова: методична розробка, вища школа, англійська мова, графічна дисципліна.

Башта Е.Т., Джурик Е.В., Джурик Н.А. Методическое обеспечение преподавания графических дисциплин в англomовном проекте НАУ. Рассматривается методическое обеспечение учебного процесса при преподавании графических дисциплин на английском языке.

Ключевые слова: методическая разработка, высшая школа, английский язык, графическая дисциплина.

Problem formulation. Eurointegrational process requires the adaptation to Europe standards by Ukrainian higher schools. One of the first steps in this direction is the transition of professing in English language. The practice of profession of general education and special disciplines is needed to be adapted with European practice.

In last years in most of academies of Ukraine there are special projects within the framework of which students (as Ukrainian, as foreign) are studying all the course of education in English. Russian and English languages are the official languages of ICAO. ICAO (International Civil Aviation Organization) is the specialized UN agency that sets international standards of civil aviation and coordinates its development with the goal to improve safety and efficiency. It also ensures the organization and coordination of international cooperation in all matters of civil aviation. So, teaching English is especially important in aviation universities. In particular, in National Aviation University (within special project) exists the program for twelve technical departments in which all the subjects from the first to the fifth or sixth years are taught in English.

The main part. Department of Computer Technologies of Design and Graphics of NAU provides teaching of such disciplines as "Descriptive Geometry", "Descriptive Geometry and Engineering Graphics", "Engineering Graphics", "Engineering and Computer Graphics", "Computer Graphics" in English for eleven technical specialties.

To support the learning process, all educating work programs and complex tests for detecting the residual knowledge were translated into English. All calculations and graphic works, homework assignments, tests, module tasks, module tests and examination cards are created in English. Lectures are also delivered in English.

An urgent need in writing of methodic literature that would help with studying of descriptive geometry, engineering and computer graphics in English appeared. The authors published methodical books like "Problems and exercises of Descriptive Geometry" (which consists of problems in descriptive geometry without examples of solution), furthers for laboratory works "Computer Graphics" (consisting of tasks, options and examples of their implementation using two graphics systems - AutoCAD and P-CAD), next a textbook "Geometric Constructions with elements of Computer Drawing" (consisting of two parts: "General rules of drawings," where basic terms and definitions are set according to ГОСТ 3321-96 and "Geometric constructions" with application of graphic system in AutoCAD), two manuals "AutoCAD" (containing theoretical material and tasks with options and examples of their implementation).

During the teaching of engineering and computer graphics in the first and second years several problems appeared, because most of students, who are fluent in English, usually do not orientate in technical terms and it is difficult for lecturer to explain their meanings.

Therefore, the authors developed and published Ukrainian-Russian-English illustrated textbooks which includes, "Glossary of descriptive geometry, engineering and computer graphics," which has not only translational function, but also interprets the meaning of technical terms. The dictionary is published with the approval of the Ministry of Education and Science of Ukraine.

The proposed tutorial is not a systematic course in engineering and computer graphics. Its purpose is to help students and teachers, who study or teach these subjects in English.

In the dictionary, explanations are made in the form of internationally accepted symbols, drawings, diagrams, charts, formulas. Typically, this illustration shows the image that is most prevalent in the international educational and technical literature for explanation of this term. Illustrations are made in simple graphical language that facilitates the understanding.

Illustrations, except from informational purpose help to memorize the material which has been illustrated. Therefore, in textbooks this illustrates the meaning of terms which would also be clear without explanation.

Nowadays, the student must have an understanding of those technological processes, with the help of manufactured products, naming various complex materials. Therefore, engineering graphics course has a close connection with many technical disciplines and the Glossary provides many terms (Fig. 1) which are used in general engineering industries.

2.2.2. З'єднання
Соединение
Joint

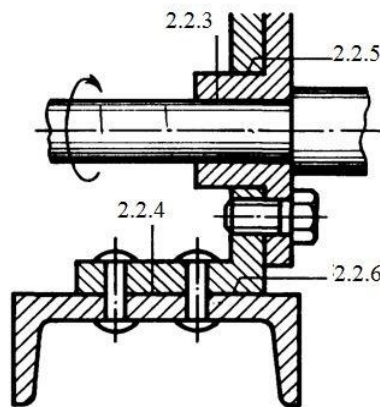

2.2.3. Рухоме з'єднання
Подвижное соединение
Movable joint

2.2.4. Нерухоме з'єднання
Неподвижное соединение
Fixed joint

2.2.5. Рознімне з'єднання
Разъемное соединение
Detachable joint

2.2.6. Нерознімне з'єднання
Неразъемное соединение
Permanent joint

Fig. 1. Types of joint, presented in the Glossary, "Machine elements" part
[authoring]

The studying of fundamental mathematics in particular, descriptive geometry, in technical high schools is very important in the formation of future engineers. Reduction of hours of a course of descriptive geometry, it's mainly semester passage determines the reduction of amount considered questions. There are some differences in lectures and practical and laboratory classes in English. It should be noted that the information in a foreign language is absorbed by students much more slowly than on the mother tongue so, as a result the lack of time appears. In the study of descriptive geometry course there are also some difficulties associated with poor development of spatial imagination of the students. Therefore, the authors have developed and published, "Problems in descriptive geometry" in English.

The original collection includes problems which correspond to the course program of descriptive geometry for technical specialties.

It can be used by students during their studying "Descriptive Geometry" as a certain subject and as composite part of educative disciplines like "Descriptive Geometry and Engineering Graphics", "Engineering and Computer Graphics" which are studied on technical specialties in the National Aviation University as well as in other higher technical educational universities.

With the introduction of the Bologna system the number of classroom hours reduces and the number of hours of private study increases. That is why the main purpose of the textbook is to help students in their independent work. This fact determined such nature of the textbook, as showing the process of solving some typical problems related to the major issues of the course.

Basically, solved problems and tasks that are proposed to be explored independently, includes the most common metric and positional problems on point, line and plane. Quite a lot of attention is paid to positional consideration of problems on curves and multifaceted surfaces which are the most complex and significant part of the course in descriptive geometry. It consists of lectures, practical studies, performing of graphic works and self-studying. At the lecture the students are acquainted with theoretical basis of the course. At practical class students solve problems under lecturer's guidance. During performing the graphical work and self-study students consolidate obtained knowledge.

Usually in the book of problems in this discipline exists only the statement of a problem and its result. For students of the first courses it is nearly impossible to follow the track of performed constructions because of a large number of lines in one drawing. But in "Descriptive geometry in worked problems" in English, pictorial sketches are provided in some of the solved patterns to ensure a better understanding of the essence of the task and a clear spatial concept. The initial drawing is suggested to be copied for the better comprehension of the worked problems and mastering the relevant constructions. Thus the student can perform all necessary constructions on this copy. There are references (in square brackets), which are in the list of literature for those, who want to familiarize with theoretical information in details.

Compared to existing and applied in the present time literature, " Descriptive geometry in worked problems " in English is followed by a gradual solution of problems which has a distinct advantage in the structure where the solving of each task is divided into several stages with a detailed text explaining of the graphics. This makes it easier to read the drawing and to follow the sequence of their construction. Many problems, which demand complicated solutions, containing additional theoretical material, that is necessary for solving the given problem. With such a structure, students without the help of a teacher can solve problems, do graphical work and develop their spatial vision.

At the beginning of this book graphical solutions of typical problems, relating to the basic precepts of the course are given. After that theoretical knowledge and text description of the problems solutions are given.

For example:

Problem 81. Construct the cross-section of the screw cut by the horizontal plane α (α_2).

The surface generated by the movement of a plane figure over the surface of a cylinder along a helix contained in it, so that the plane of the figure always passes through the axis of the cylinder, is called a helical surface. The body limited by this surface is called a screw. The threads of screw are of different shapes, depending on the form of the generating profile, i.e., dependent on the shape of the plane figure being moved. Among the threads most commonly used are of square, rectangular, triangular, trapezoidal and semicircular cross section.

Step 1. Screw has a thread of triangular section. Obtain the characteristic points 1 (11, 12) and 2 (21, 22).

Step 2. Through axis of the screw draw auxiliary plane $\beta(\beta_1)$, perpendicular to the plane of projection Π_1 . This plane intersects each protrusion in triangular. Obtain the profile of thread ABC ($A_1, B_1, C_1; A_2, B_2, C_2$). The point 3 ($3_1, 3_2$) in which plane α intersects side AB of this triangle, is the point contained in the line of intersection the screw and plane α . Having constructed the horizontal projection 3_1 of this point.

Step 3. Through axis of the screw draw auxiliary horizontal-projecting plane $\mu(\mu_1)$. Construct point 4 ($4_1, 4_2$) in the similar method.

Step 4. Construct horizontal-projecting planes $\delta(\delta_1), \theta(\theta_1)$ and construct points 5 ($5_1, 5_2$) and 6 ($6_1, 6_2$) in the similar method.

Step 5. Join the points $1_1, 3_1, 5_1, 4_1, 6_1$ and 2_1 by a continuous line, obtained the horizontal projection of one of the branches of the line of intersection of the screw and plane α . The other branch of this curve symmetrical to given branch in relation to the axis of symmetry 1121 of screw.

Plane α intersects the given surface along an arc of the spiral of Archimedes.

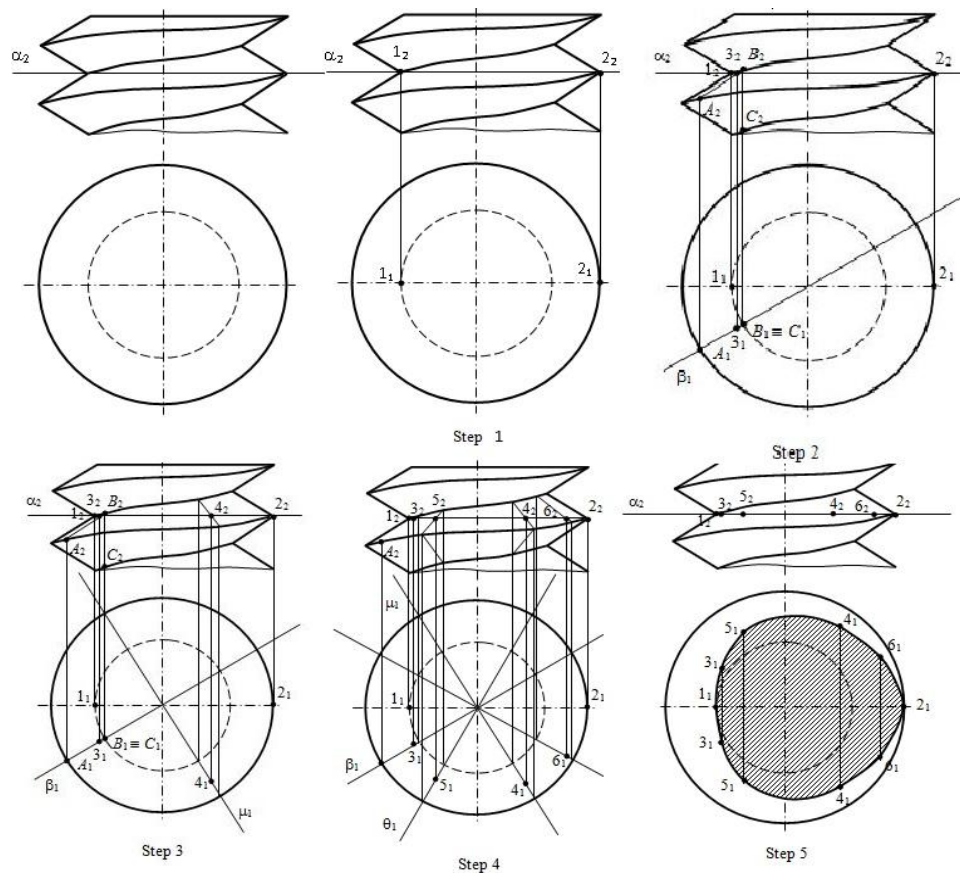

Fig. 2. Solution of a problem 81 of Chapter 8 «Cylindrical and conical helical lines and screws» [authoring]

It is very difficult to put all the necessary material in English in the given time for lectures. Thus, it should be considered when the workload being planned.

Conclusion. In students, studying of graphical disciplines in English, there are certain difficulties. That is why the development of illustrated manuals and other materials for these subjects in English facilitates the learning of material.

Therefore, teaching courses in English should be directed not only on achieving deep professional skills, but also on professional communication that is necessary to establish the scientific and business cooperation with European countries.

The search of new solutions goes on all the time, and there is the prospect of Ukraine's approach to the educational level of Europe.

1. Ковальов Ю.М. Проблеми викладання інженерної та комп'ютерної графіки англійською мовою / Ю.М.Ковальов, О.Т.Башта, О.В.Джурик, Н.О.Гірник // Новітні комп'ютерні технології. Матеріали VII Міжнародної науково-технічної конференції – К.: Міністерство регіонального розвитку та будівництва України, 2009. – С. 107 – 108.
2. Башта О.Т. Teaching of discipline «Computer Graphics» in the professional training of specialists of Computer sciences / О.Т.Башта, О.В.Джурик, Н.О.Гірник, Ю.Ю.Грищенко // Новітні комп'ютерні технології. Матеріали X Міжнародної науково-технічної конференції – К.: Міністерство регіонального розвитку та будівництва України, 2012. – С. 10 – 13.
3. Башта О.Т. Комплексний підхід до викладання графічних дисциплін англійською мовою / О.Т.Башта, О.В.Джурик, Н.О.Гірник, Т.В.Ізюменко // Інноваційні аспекти геометро-графічної освіти. Матеріали всеукраїнської науково-методичної конференції – Севастополь: Севастоп. нац. техн. ун-т, 2012. – С. 87 – 90.