

DOI: 10.31319/2519-8106.2(41)2019.185063

UDC 621.7.06:622

**A.I. Beztsinnyi**, head of the laboratory

**N.M. Volosova**, Candidate of Technical Sciences (Ph. D.), Associate Professor, volosonata@ukr.net

**A.L. Yatsuk**, senior teacher, annyatsuk36@gmail.com

Dniprovsk State Technical University, Kamianske

## MODELLING OF LOADING DISTRIBUTION TO ROLLERS SUPPORTS OF ROTATING DRUM

*The paper analyzes the factors that must be taken into account when designing machines of the drum type. The method of determining the reactions of the reference rollers of the drum type machines with the consideration of the uneven distribution of the charge material along the length of the drum and the angle of the installation of the drive gear is proposed.*

**Keywords:** modeling; drum type machines; angle of a drive gear installation; support rollers; charge material.

*В роботі проаналізовано фактори, які необхідно враховувати при проектуванні машин барабанного типу. Запропоновано методику визначення реакцій опорних роликів машин барабанного типу з урахуванням нерівномірності розташування шихтового матеріалу по довжині барабана та кута установки приводної шестерні.*

**Ключові слова:** моделювання; машини барабанного типу; кут установки приводної шестерні; опорні ролики; шихтовий матеріал.

### Formulation of the problem

Prospects for the development of mining and metallurgical complex technological lines for the preparation of ore materials involve the creation of units of high unit capacity. The design of drum type machines requires the development of more accurate methods of calculation, since it becomes irrational to compensate for the errors of approximate calculations. This leads to the necessity in their design to take into account the influence of a number of factors that have not yet been taken into account in the calculations.

### Analysis of the latest research and publications

The question of reactions determining for drum type machines supports is given attention in scientific work [1]. In this work, the calculation of the reactions of the supports of the machines of the drum type is carried out in the combination of both pairs of the support rollers and the gear crown in the same thickness, without considering the effect on their value of uneven distribution of charge material along the length of the drum, without taking into account friction in the support and rotary part of the machine links with respect to the vertical axis of the drum. There are no experimental studies of the supporting rollers reactions in the working condition of the machine. It is concluded that to calculate the reference units it is sufficient to determine the static load. In [2], the results of measuring the thickness of a layer of charge material in a rotating drum at different speeds of rotation are presented. It is found that the charge along the length of the drum can be evenly spaced with a certain slope toward the unloading side of the drum, or unevenly with considerable concentration on the loading side. This irregularity reaches three times the thickness of the charge layer on the loading side over the thickness on the loading side. Such significant irregularity extends to almost half the length of the drum, and this results in considerable uneven loading of the roller supports along the length of the drum, which is not taken into account in previous studies.

### Formulation of the study purpose

The purpose of the work is to develop a method of calculating the reactions of the machines supports for the drum type taking into account the uneven location of the charge material in the drum along its length, the influence of friction forces arising in the support-rotary part of the machine during its operation, as well as the angle of installation of the drive link with respect to the vertical the axis of the drum. To achieve this goal, the following tasks must be accomplished:

- determine the location of the charge material gravity in the drum in the transverse and longitudinal thicknesses in the drum;
- find the value of the force in the gearing by the iterative procedure;
- determine the rational location of the gear crown on the drum to ensure a uniform distribution of forces on the supports along the length of the drum.

#### Presenting main material

The scheme of the drum type machine with a gear drive of the drum is shown in fig. 1, using the following designations: 1 — drum; 2 — charge material; 3 — a bandage; 4 — the supporting roller; 5 — crown gear; 6 — drive gear;  $P_1, P_2, P_3, P_4$  are the reactions of the rollers;  $P_b$  — weight of the drum;  $P_m$  — the weight of the charge;  $P_z$  is the force in the gearing.

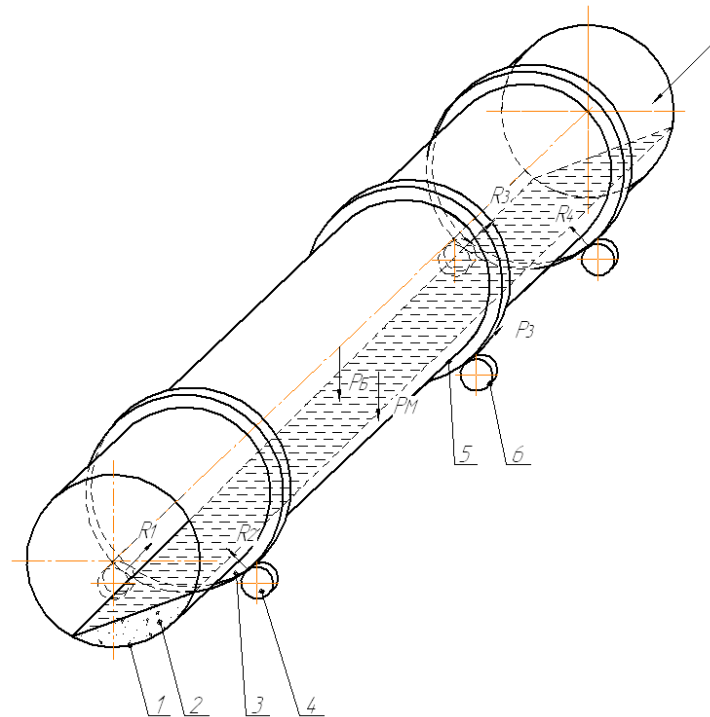

Fig. 1. Schema of a drum type machine with a gear drive

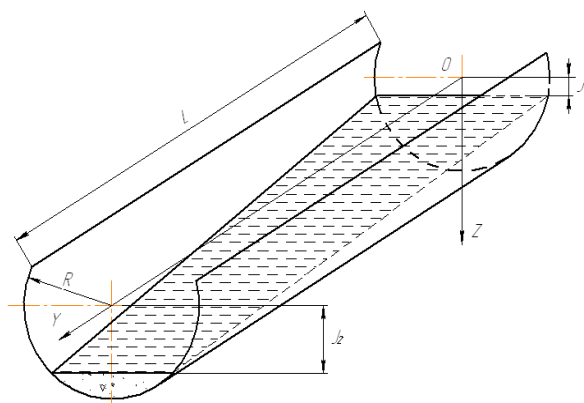

Fig. 2. The schema of the charge with a uniform slope

In the first step, to solve the main disadvantage of the previously existing methods, we determine the location of the center of gravity of the charge material in the drum in the transverse and longitudinal thicknesses. In Fig. 2 shows a diagram of the location of the charge in the drum with a uniform slope with the corresponding notation:  $R$  is the radius of the drum;  $l_1, l_2$  is the distance from the center of the drum to the chord of the charge segment, respectively, on the loading side and on the unloading side;  $L$  is the length of the drum.

The coordinate of the center of gravity of the segment cylinder of the charge relative to the axis  $OY$  is determined by the formula

$$y_c = \frac{\iiint_V y \cdot dx dy dz}{V} = \frac{\iiint_V y \cdot dx dy dz}{\iiint_V dx dy dz}, \quad (1)$$

Each of the triple integrals is determined and calculated and substituted into formula (1). After transformations and calculations, we obtain the coordinate of gravity center on the axis  $OY$ , dividing the corresponding values of the found integrals:

$$\begin{aligned} \iiint_V y dx dy dz &= \frac{\pi R^2 L^2}{4} - \frac{R^4}{\delta^2} \left[ \frac{2 \cdot l_2^2 - R^2}{4R^2} \arcsin \frac{l_2}{R} + \frac{l_2 \sqrt{R^2 - l_2^2}}{4R^2} - \frac{l_1 \cdot l_2}{R^2} \arcsin \frac{l_2}{R} - \frac{l_1 \sqrt{R^2 - l_2^2}}{R^2} - \right. \\ &- \frac{2 \cdot l_1^2 - R^2}{4R^2} \arcsin \frac{l_1}{R} - \frac{l_1 \sqrt{R^2 - l_1^2}}{4R^2} + \frac{l_1^2}{R^2} \arcsin \frac{l_1}{R} + \frac{l_1 \sqrt{R^2 - l_1^2}}{R^2} \left. \right] - \frac{1}{\delta^2} \left[ \frac{R^2 l_2 \sqrt{R^2 - l_2^2}}{8} - \frac{l_2 (\sqrt{R^2 - l_2^2})^3}{4} + \right. \\ &+ \frac{R^4}{8} \arcsin \frac{l_2}{R} + l_1 (R^2 - l_2^2)^{3/2} + \frac{l_1 (\sqrt{R^2 - l_1^2})^3}{4} - \frac{R^4}{8} \arcsin \frac{l_1}{R} - \frac{l_1 (R^2 - l_1^2)^{3/2}}{3} \left. \right]; \\ V &= \iiint_V dx dy dz = \frac{\pi R^2 L}{2} - R^2 \left( \frac{\delta \cdot L + l_1}{\delta} \arcsin \frac{\delta \cdot L + l_1}{R} + \frac{\sqrt{R^2 - (\delta L + l_1)^2}}{\delta} - \right. \\ &- \frac{l_1}{\delta} \arcsin \frac{l_1}{R} - \frac{\sqrt{R^2 - l_1^2}}{\delta} \left. \right) - \frac{1}{3\delta} \left[ (R^2 - l_1^2)^{3/2} - (R^2 - l_2^2)^{3/2} \right]^\delta, \end{aligned}$$

where  $\delta = \frac{l_2 - l_1}{L}$ .

Then the coordinate of the gravity center of the charge along the axis  $OZ$  is determined by the formula

$$z_c = \frac{\iiint_V z \cdot dx dy dz}{V} = \frac{\iiint_V z \cdot dx dy dz}{\iiint_V dx dy dz}. \quad (2)$$

After completing the necessary transformations and calculations, we obtain the value for the integral in the numerator of the formula (2):

$$\iiint_V z \cdot dx dy dz = \frac{1}{12\delta} \left( 3AR^2 - 2C + 3R^4 \arcsin \frac{B}{R^2} \right),$$

where  $A = l_2 \sqrt{R^2 - l_2^2} - l_1 \sqrt{R^2 - l_1^2}$ ;

$B = l_2 \sqrt{R^2 - l_1^2} - l_1 \sqrt{R^2 - l_2^2}$ ;  $C = l_2 \sqrt{(R^2 - l_2^2)^3} - l_1 \sqrt{(R^2 - l_1^2)^3}$ .

In the case where the surface of the charge in the drum has a constant slope, as shown in fig. 3 (curve AB), we use graphoanalytic method to find the center of gravity of the charge [4].

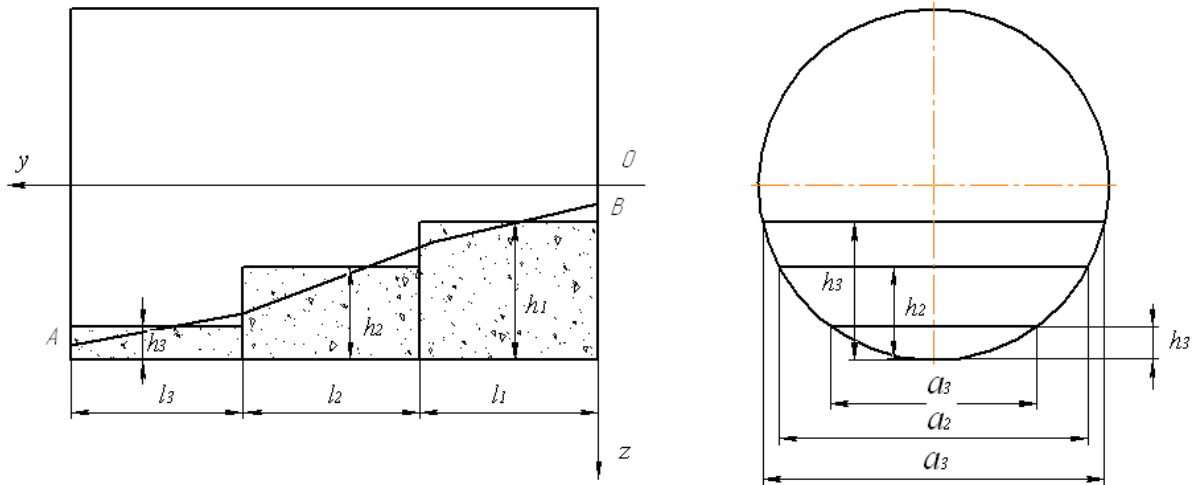

Fig. 3. Graphoanalytic method for finding the center of the charge gravity

For this purpose, the charge material in the drum is broken into a series of segment cylinders with length  $l_i$ . Replaced cylinders in cross-sectional area should be equal to the replaced cylinders. For each cylinder the chord « $a_i$ » and the arrow « $h_i$ » are measured. In relation  $a_i/h_i$  to the tables [3] we determine the length of the chord  $a_i$  and the area of the segment  $f_i$ . Then the volume of each substituted drum cylinder segment is determined by the formula

$$V_i = f_i \cdot l_i \cdot R^2,$$

where  $R$  — the radius of the drum;  $l_i$  — the length of the cylinder.

The distance from the origin to the center of gravity of the OY axis will be

$$y_c = \sum_{i=1}^n V_i \cdot y_i,$$

where  $y_i$  — the coordinate of the center of gravity of the  $i$ -th segment cylinder from the origin.

The distance from the axis of the drum to the center of gravity of each segment cylinder is given by the formula

$$z_i = \frac{a_i^3 \cdot R}{12 \cdot f_i}.$$

The distance from the axis of the drum to the center of gravity of the charge in the drum along the axis OZ is determined as follows:

$$z_c = \frac{\sum_{i=1}^n V_i \cdot z_i}{\sum_{i=1}^n V_i}.$$

Then the moment on the axis of the drum by the weight of the charge is calculated by the formula:

$$M_1 = P_m \cdot z_c \cdot \sin \gamma,$$

where  $P_m$  — the weight of the charge;  $\gamma$  — the angle of lift of the center of charge in the drum as it is rotated.

Thanks to the found torque value, it is possible to determine in the first approximation the force in the gearing [5]

$$P'_3 = \frac{2M_1}{D_r \cdot \cos \alpha},$$

where  $D_r$  — the diameter of the initial circle of the teeth of the drive crown;  $\alpha$  — the gearing angle of the involute gear.

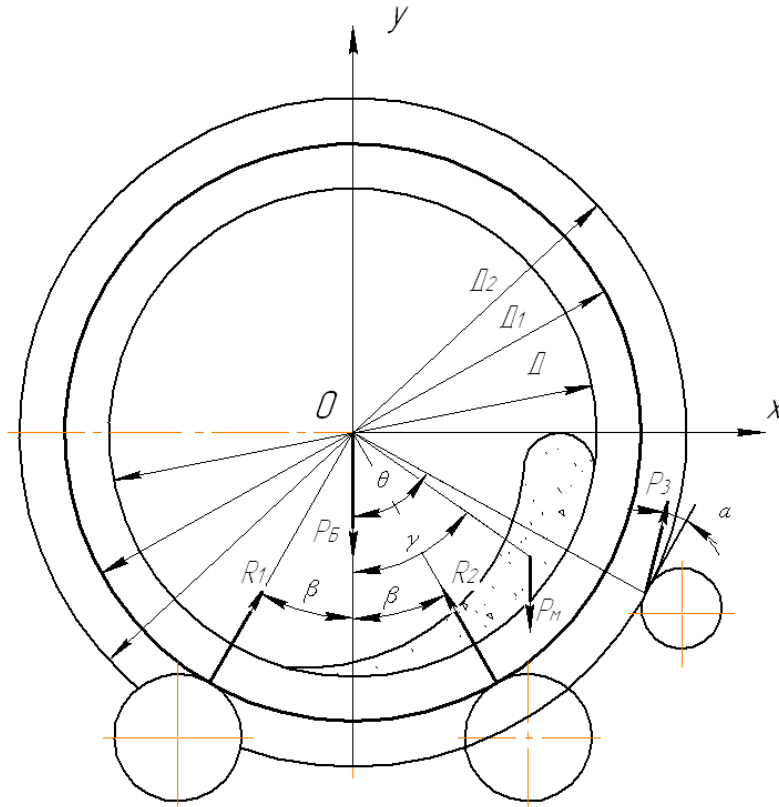

Fig. 4. The location of the charge in the drum

According to fig. 4 we project all forces on the axis OX and OY and from these equations we determine the reactions  $R'_1$  and  $R'_2$  in the first approximation

$$R'_1 = P_2 - P'_3 \frac{\cos(\theta_i + \alpha)}{\sin \beta};$$

$$R'_2 = \frac{P_5 + P_m + P'_3 [\cos(\theta_i + \alpha) \operatorname{ctg} \beta - \sin(\theta_i + \alpha)]}{2 \cos \beta},$$

where  $P_5$  — the weight of the drum;  $\beta$  — the angle of installation of the support roller with respect to the vertical axis of the drum;  $\theta_i$  — the angle of installation of the drive gear relative to the vertical axis of the drum.

Given the values of the reactions  $R_1$  and  $R_2$ , we find the moment of friction in the support of the machine. The torque from the friction forces in the roller bearings reduced to the axis of the drum is calculated as follows

$$M'_2 = (R'_1 + R'_2) \frac{d_u}{2} \cdot f \frac{D_1}{d_p},$$

where  $d_y$  — the diameter of the pin of the roller;  $f$  — coefficient of friction in the roller bearings;  $D_1$  — diameter of the bandage;  $d_p$  — the diameter of the support roller.

The moment from the friction forces of the rollers on the rollers, brought to the axis of the drum is calculated by the formula

$$M'_3 = (R'_1 + R'_2)k \cdot \frac{D_1}{d_p},$$

where  $k$  — the coefficient of rolling friction for the bandages to the rollers.

Thus, the total moment of resistance forces on the axis of the drum is equal  $M'_\Sigma = M_1 + M_2 + M'_3$ .

Thence in the second approximation, the values of the force in the gearing are obtained  $P_3'' = \frac{\alpha \cdot M'_\Sigma}{D_2 \cdot \cos \alpha}$ .

If the force  $P_3''$  value differs from the force  $P_3'$  value by less than 5%, then the force value  $P_3''$  is finite for finding reactions  $R_1''$  and  $R_2''$ . If the difference between the values  $P_3'$  and  $P_3''$  is greater than 5%, then the calculation of the response of the supports should be continued.

By determining the ultimate force  $P_3$  and having the coordinate value  $uc$  of gravity center of the charge, we can determine the optimal location of installation of the gear crown on the drum. This will ensure a uniform distribution of forces on the supports along the length of the drum [6].

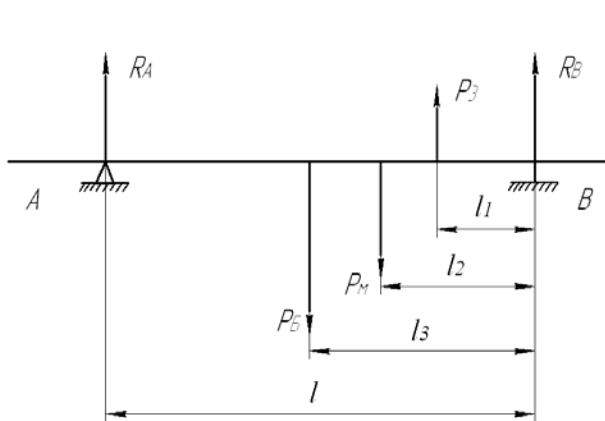

Fig. 5. Scheme for determination of supports reactions

Considering the drum as a double support beam according to fig. 5, determine the distance of installation of the crown on the drum from the support B

$$l_1 = \frac{P_B \cdot l_3 + P_m \cdot l_2 - R_A \cdot l}{P_3},$$

where  $l$  — the distance between the supports along the length of the drum;  $l_2$  — distance from support B to the line of action of the force  $P_m$ ;  $l_3$  — distance from support B to the force  $P_B$  line.

The angle of the drive gear installation also has a significant effect on the magnitude of the reactions of the supports. In fig. 6 shows the graphs of the reactions of the support rollers  $R_1$  and  $R_2$  depending on the angle of installation of the drive gear for a drum with a diameter of 2.8 m, length 8 m when loading 10% and 30%, respectively. As can be seen from the graphs, the angle of installation of the drive gear relative to the vertical axis of the drum at  $70^\circ$  is optimal. For a given angle, the values of the supports take the same values and are in the area of the smallest values.

For the fractional actuator, the optimization of the rollers force interaction with the drum is limited due to the inability to change the installation of the drive link with respect to the vertical axis of the drum.

The confirmation of the reliability of the proposed method of calculation of the reference reactions are the experimental data obtained for the case of oscilloscope bending moments in the housing of the mixer mixer drum type SBF 2,8×8 m [7]. The bending stress was measured by the resistance sensors that were attached to the drum between the blocks of the supporting rollers. The circuit diagram was coupled to a cat strain gauge with the measurement signal fixed on a beam oscilloscope. A fragment of the working waveform of bending stresses in the drum is shown in fig. 7. The point 1

shows the stresses under the driving cat, and at point 2 — under the irreducible for the case of the direction of the wheel force on the driving cat upwards. The angle of installation of the rollers to the vertical axis of the drum is within  $30^\circ$ . The nature of the waveform shows that the bending moments under the cats in the drum housing differ from each other almost twice in size, as confirmed by the calculations.

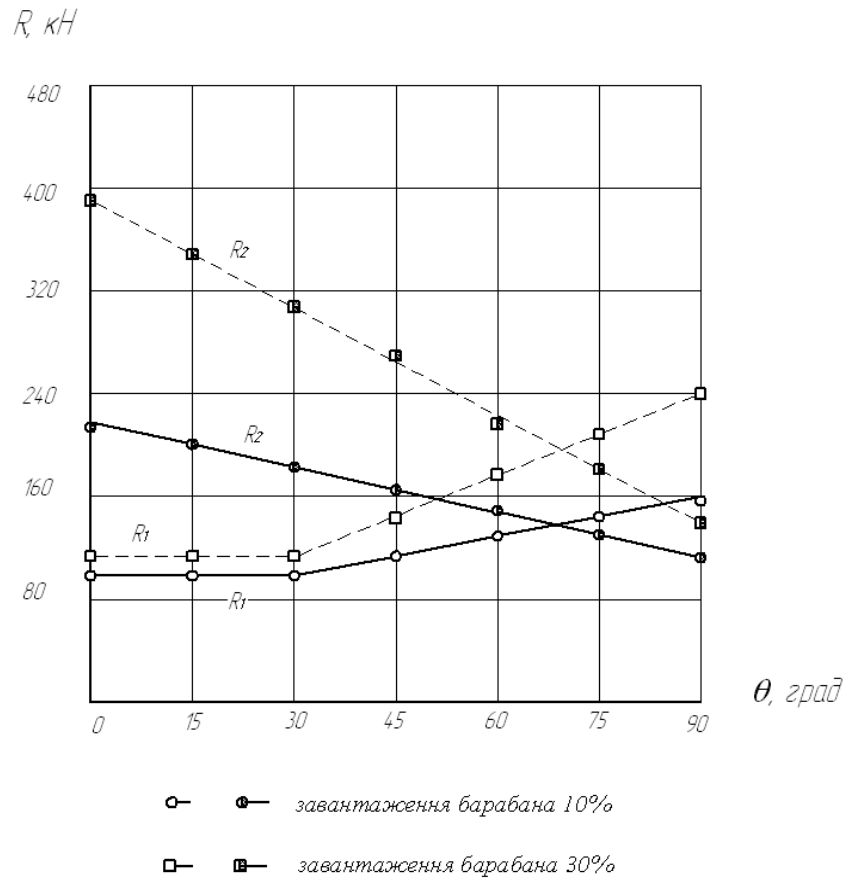

Fig. 6. Graph of changes in reactions of supports



Fig. 7. Working waveform of bending stresses in the drum

### Conclusions

The method proposed in this work, the analytical and graphical solutions constructed on it, have undergone experimental testing and allow to determine with accuracy 0.95 the reactions of the supporting rollers of machines of the drum type, taking into account the irregularities of the location of the bulk material in the drum in its length, depending on the installation. relative to the vertical axis of the drum. The developed model allows to obtain reliable results for design and testing calculations of rollers, braces and drum for strength.

### References

- [1] Grigoriev, G.G. & Sverdlik, G.I. (1971) Opredeleniie nagruzok na opornye roliki barabanyh smesiteley i okomkovateley [Determination of loads on the support rollers of drum mixers and pelletizers] / Г.Г.Григорьев, Г.И.Свердлик // Proceedings of the 2<sup>nd</sup> Conference: *II Vsesouznaya konferentsiia "Dinamika krupnih mashin"* – All-Union Conference on the Dynamics of Large Machines. (pp.2-4).Sverdlovsk [in Russian].
- [2] Korotik, V.I. & Ganesberg A.G. (1968) Rabota barabannyh okomkovateley shihty [Work drum pelletizer charge] *Metalurgii – Metallurgy*, 1, 3-5 [in Russian].
- [3] Bronshteyn, I.N. & Semendiaiev, K.A. (1986) *Spravochnik po matematike dlia inzhenerov I uchashshihcia vtuzov* [Handbook of mathematics for engineers and students of technical colleges] M.: Nauka [in Russian].
- [4] Zhuk, A.Y. & Zheliabina N.K. (1998) *Mehanichne ustatkuvannia tsehv po vyrobnytstvu metaliv ta splaviv* [Mechanical equipment of workshops for the production of metals and alloys].Zaporizhia: ZDIA [in Ukrainian].
- [5] Molochnikov, N.V. (Ed.) (1970) *Aglomeratsionnoie, okomkovatelnoie i domennoie oborudovaniie: Katalog-spravochnik* [Sintering, cutting and blast furnace equipment: Directory - Reference] M.: NIIInformtiazhmash [in Russian].
- [6] Shcherbina, V.Yu., Saharov, O.S., Samilenko, Yu.N. & Bobah, V.V. (2009) Doslidzhennia termomechanichnyh navantazhen v obertoviy pechi z vyhrovym teploobminnykom [Investigation of thermomechanical loads in a rotary furnace with a vortex heat exchanger] *Naukovy visty NTUU "KPI"* – Science News of NTUU "KPI", 6, 26-33 [in Ukrainian].
- [7] Beztsinnyi, A.I., Volosova, N.M. & Yatsuk, A.L. Metodyka vyznachenia rozpodilu navantazhen na rolykoopory obertauchih barabaniv [Method of determining the distribution of loads on roller bearings of rotating drums] Proceedings of the International Conference: *Mizhnarodna naukova konferentsiia "Matematychni problem tehnychnoyi mehaniky ta prikladnoiimatematyky -2019"* – International Scientific Conference "Mathematical Problems of Technical Mechanics and Applied Mathematics - 2019". (p.97). Dnipro-Kamyanske [in Ukrainian].

### МОДЕЛЮВАННЯ РОЗПОДІЛУ НАВАНТАЖЕНЬ НА РОЛИКООПОРИ ОБЕРТАЮЧИХ БАРАБАНІВ

Безцінний А.І., Волосова Н.М., Яцук А.Л.

#### Реферат

Проектування машин барабанного типу вимагає розробки більш точних методів обчислення, оскільки компенсувати помилки стає недоцільним. Це призводить до необхідності при їх проектуванні враховувати вплив різних факторів, які до цього часу не бралися до уваги при розрахунках. Тому це питання наразі є актуальним завданням.

Мета роботи полягає в розробці методики розрахунку реакцій опор машин барабанного типу з урахуванням нерівномірності розташування шихтового матеріалу в барабані по його довжині, впливу сил тертя, що виникають в опорно-поворотній частині машини при її роботі, а також кута установки приводної ланки по відношенню до вертикальної осі барабана. Для досягнення поставленої мети поставлені наступні задачі:

- визначити розташування центру ваги шихтового матеріалу в барабані у поперечній і поздовжній товщинах в барабані;
- знайти значення сили в зубчастому зачепленні за ітераційною процедурою;
- визначити раціональне місце установки зубчастого вінця на барабані для забезпечення рівномірного розподілу сил на опори по довжині барабана.

Суттєвий вплив на величину реакцій опор здійснює також кут установки приводної шестерні. Оптимальним є кут установки приводної шестерні по відношенню вертикальної осі



барабана в  $70^\circ$ . Для даного кута значення опор приймають однакові значення і при цьому знаходяться в зоні найменших значень.

Запропонована в роботі методика, побудовані за нею аналітичні і графічні розв'язки пройшли експериментальну апробацію і дозволяють з достовірністю 0,95 визначати реакції опорних роликів машин барабанного типу з урахуванням нерівномірностей розташування сипучого матеріалу в барабані за його довжиною, в залежності від кута установки приводної шестерні по відношенню вертикальної осі барабана. Розроблена модель дає можливість отримати достовірні результати для проектних та перевірочних розрахунків роликів, бандажів та барабану на міцність.

### Література

1. Григорьев Г.Г., Свердлик Г.И. Определение нагрузок на опорные ролики барабанных смесителей и окомкователей. *Динамика крупных машин*: материалы II всесоюз. конференции (м.Свердловськ, 17-18 трав. 1971 р.). Свердловськ, 1971. С.2-4.
2. Коротик В.И., Ганесберг А.Г. Работа барабанных окомкователей шихты. *Металлургия*. 1968. №1. С. 3-5.
3. Бронштейн И.Н., Семендяев К.А. Справочник по математике для инженеров и учащихся втузов. Изд.13-е, испр. и доп. Москва: Наука, 1986. 544 с.
4. Жук А.Я., Желябіна Н.К. Механічне устаткування цехів по виробництву металів та сплавів: навч. посіб. Запоріжжя: ЗДІА, 1998. 210 с.
5. Агломерационное, окомковательное и доменное оборудование: кат.-справоч./ред. Н. В. Молочникова. Москва: НИИИнформтяжмаш, 1970. Ч. 1. 165 с.
6. Щербина В.Ю., Сахаров О.С., Самиленко Ю.Н., Бобах В.В. Дослідження термомеханічних навантажень в обертовій печі з вихровим теплообмінником. *Наук. вісті НТУУ «КПІ»*. Київ, 2009. № 6. С. 26-33.
7. Безцінний А.І., Волосова Н.М., Яцук А.Л. Методика визначення розподілу навантажень на роликоопори обертаючих барабанів. *Математичні проблеми технічної механіки та прикладної математики – 2019* : матеріали міжнародної наук. конф. (Дніпро-Кам'янське, 15-18 квіт. 2019 р.). Кам'янське, 2019. С.97.