

МОДЕЛЮВАННЯ ТА ОПТИМІЗАЦІЯ В ТЕХНОЛОГІЇ КОНСТРУКЦІЙНИХ МАТЕРІАЛІВ



DOI: 10.31319/2519-8106.2(41)2019.185045

UDC 621.865.8

A.D. Romaniuk, Cand. Tech. Sci., Dozent, oleksandrromaniuk5@gmail.com

Dnieper State Technical University, Kamianske

DEVELOPMENT OF ROTARY UNITS MECHANICAL TRANSMISSION MATHEMATICAL MODEL

In this paper a mathematical model of the assembly unit of the mechanical transmission rotation node is developed. On its base the dependences for calculating the mass of the rotational element of the model of the bearing shaft were obtained. The introduced general coefficients of constructive conversion of geometric parameters make it possible to estimate the mass of the rotating element in the first approximation at the stage of preliminary designing to stabilize the kinematic and dynamic characteristics of the machine aggregate without the use of additional masses.

Keywords: mechanical transmission; mass; shaft; rotary knot; designing.

В даній роботі розроблена математична модель складальної одиниці вузла обертання механічної передачі на основі якої отримано залежності для розрахунку маси обертального елемента моделі валу з підшипниками. Введені загальні коефіцієнти конструктивного перерахунку геометричних параметрів дають можливість оцінити масу обертального елемента в першому наближенні на етапі попереднього проектування з метою стабілізації кінематичних та динамічних характеристик машинного агрегату без використання додаткових мас.

Ключові слова: механічна передача; маса; вал; обертальний вузол; проектування.

Problem's Formulation

During designing the actuator of the machine unit, standard mechanical gears are used, among which the most common gearboxes. The main elements of such components are the nodes that carry out rotational motion. The weight of such assemblies is more than two thirds of the weight of the gearbox. Therefore, given that in steady-state motion the kinematic and power characteristics of the rotating units of the mechanism are periodic functions due to the amplitude oscillations of the transfer function, there is a need to reduce the amplitude of oscillations of the link speed. On this basis, the problem of optimizing the kinematic and power characteristics of the actuator of the machine unit is solved in various ways. The most common is the use of additional masses [1,2,3,4]. The use of a flywheel makes it possible to significantly reduce the amplitude of oscillations of the speed of the link, as it causes an increase in the reduced moment of inertia of the mechanism. The disadvantage of installing the flywheel is the extra mass, which increases the weight of the mechanism and its inertia. To avoid matching disadvantages of additional masses in the process of preliminary design of the actuator of the machine unit must be selected such a standard reducer, the maximum torque of the nodes which would correspond to the additional mass. But in practice it is almost impossible to find the right gearbox. It is more expedient to design new gearing moments of inertia of rotating masses which could serve as a flywheel.

Analysis of recent research and publications

The basic principles and approaches of designing the transmission mechanisms based on the optimization of their kinematic and force characteristics were considered in [5,6,7,8], in which the main aspect is directed to the analysis of the common elements of the drive circuit without taking into account the masses of rotating units of the drive of the executive body of the machine.

In solving this problem, it is necessary to find at the stage of preliminary design the appropriate mass of the rotary node of the mechanical transmission, which would correspond to the flywheel flywheel's moment. Given the fact that the torque of the rotating mass located on the high-speed transmission shaft is smaller than the mass on the slow-moving shaft, the task can be solved by using the rotational mass of the high-speed stage as a flywheel, which ultimately significantly reduces the overall weight of the machine. The corresponding kind of problem was solved in [9,10,11], but only considering the optimal mass of gears. These works did not consider the mass of the shaft and its mounting nodes, which is also characterized by a significant flywheel.

The tasks of designing mechanical gears, considering the optimization of the kinematic and power characteristics of the actuator of the machine unit are many criteria [9,10,11]. This is because there is a need to consider mutually dependent parameters. Especially the problem is complicated when developing a mathematical model of the elements of the assembly node of the mechanical transmission.

Formulation of the study purpose

Based on the interaction conditions between the details of the assembly unit of the mechanical transmission rotation unit (Fig. 1), which are expressed by the coupling equations describing the conditions of the transmission operation, in designing these equations form a system with a corresponding number of unknowns.

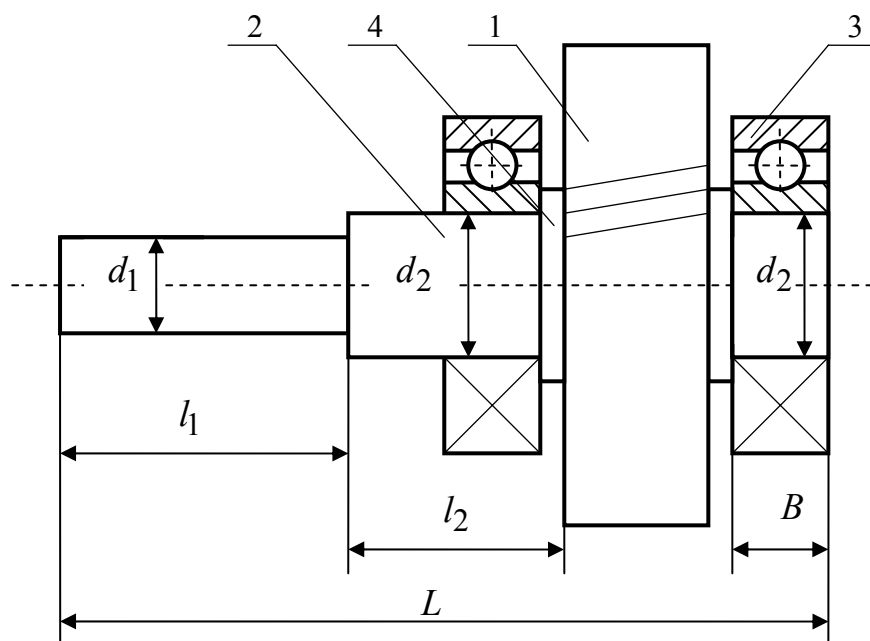

Fig. 1. Mechanical gear assembly unit: 1 — gear, 2 — shaft, 3 — shaft bearings (rolling bearings), 4 spacer sleeve

The peculiarity of designing the assembly unit of the mechanical transmission rotation unit under the condition of its optimization is that the number of unknown design values is much greater than the coupling equations, which significantly complicates the already multivariate task. Therefore, the problem of reducing the number of unknowns, using other considerations, is considered, or to allow their change within some limits, as well as to determine the influence of the relevant parameters on the nature of change in the mass of the assembly unit of the mechanical transmission rotation unit

during the design process. In this regard, it is advisable to consider the problem of optimizing the mass of individual parts of the assembly unit, as well as the introduction of restrictions on the parameters of this part. These include: functional constraints on optimization parameters; parametric restrictions; discrete restrictions. In [9, 10, 11], the problem of optimizing the mass of a gear wheel of a mechanical transmission (position 1, Fig. 1) was considered, depending on the six basic design variables.

In this case, consider the shaft of the mechanical transmission (position 2, Fig. 1), the construction of which is the most common in practice. We choose that the mass of the mechanical transmission shaft will depend on eight major unknown design variables:

1. ($x_1 = d_1$) — diameter of the output section of the shaft;
2. ($x_2 = d_2$) — the diameter of the shaft section under the bearing;
3. ($x_3 = l_1$) — length of the output section of the shaft;
4. ($x_4 = l_2$) — length of the shaft section from the side of the output part;
5. ($x_5 = B$) — length of shaft section under bearing;
6. ($x_6 = \rho$) — specific gravity of the shaft material;
7. ($x_7 = [\tau]$) — the permissible value of the tangent pressures during torsion;
8. ($x_8 = T$) — value of torque on the shaft.

Choosing the best solution or comparing the solutions will be done by some function, which is determined by the design parameters and is called the target. In the process of solving the optimization problem, the values of the parameters at which the objective function has an extremum must be found. The objective function plays the role of the basic criterion of optimality in mathematical models by which engineering problems are described.

In this case, the objective function can be written as

$$m_i = f(x_1, x_2, x_3, x_4, x_5, x_6, x_7, x_8).$$

We establish the possibility of reducing the number of variables, as well as the nature of the influence of the corresponding parameters on the mass of the shaft during its optimization.

We define the dependency and select the following constraints for the design variables.

1. The diameter of the output section of the shaft when designing is calculated from the condition of the strength of the permissible tangent pressures in the condition of pure torsion

$$d_1 \geq \sqrt[3]{\frac{T}{0,2[\tau]}}$$

The final diameter is selected according to the standard row (*Ra10, Ra20, Ra40*).

2. The diameter of the shaft section under the bearing is determined based on design standards

$$d_2 = d_1 + [2c + (3...5)],$$

where c — is the tilt radius of the transitional section of the shaft.

The final diameter is selected according to the standard row (*Ra10, Ra20, Ra40*).

3. The length of the output section of the shaft is determined based on design standards

$$l_1 = (1,8...2,5) \times d_1.$$

The residual length is selected according to the standard row (*Ra10, Ra20, Ra40*), considering the length of the keyway, which is set on this section.

4. The length of the shaft section from the side of the starting part shall be calculated considering the geometric dimensions of the respective parts and assemblies which are directly mounted on that section

$$l_2 = B + t + H + \Delta,$$

where: B — the width of the bearing, t — the width of the spacer sleeve, H — the height of the through bearing cap, Δ — the structural (safety) clearance.

The residual length is selected according to the standard row (*Ra10, Ra20, Ra40*).

5. The length of the shaft section under the bearing is determined according to the width of the selected bearing:

- for ball bearings B ;
- for roller bearings T .

In this case, we consider only ball bearings.

6. The weight of the shaft material in this case can be considered as a constant value, since the shafts are made of one material. For steel 40, 45, 40X, 40XH, of which shafts are mainly made, the specific gravity is $\rho = 7820 \text{ кг/м}^3$.

7. The permissible magnitude of the tangential stresses for torsion for steels of which mainly produce shafts in the first approximation can be considered as a constant value, since

$$[\tau] = 20 \dots 40 \text{ МПа.}$$

8. The magnitude of the torque on the shaft is constant if the speed of transmission and engine power are constant

$$T = \frac{N}{\omega},$$

where: N — power on the shaft; ω — angular speed of the shaft.

Presenting of main material

Consider the mathematical model of the shaft (Fig. 2), which is an element of the assembly unit of the rotation node of the mechanical transmission (Fig. 1). The problem of determining the mass of the gear wheel to optimize it was considered in [9,10,11], so to determine the mass of the shaft assembly must determine the mass of the shaft diameter and the mass of the inner rings of the bearing, which are installed on the press fit on the shaft.

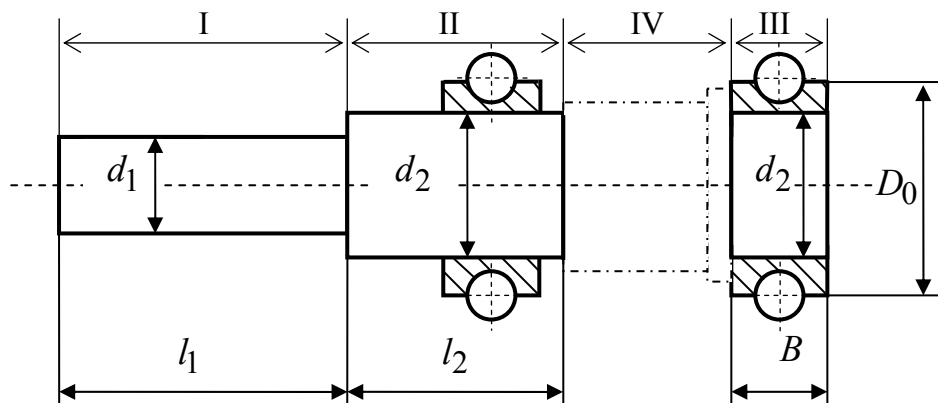

Fig. 2. Mathematical model of a shaft with bearings

The need to extend the mathematical model presented in [9] is due to the fact that the rotational mass of the mechanical transmission in the drive circuit consists not only of the mass of the gear wheel, but also the mass of the shaft and the bearings. The corresponding mass, which was not taken into account in [9], in gearboxes that transmit significant torques can almost equal the mass of the gear wheel. Thus, the extension of the mathematical model to establish the optimal mass of the assembly unit in order to stabilize the kinematic and dynamic characteristics of the machine unit is relevant.

According to the developed mathematical model of a shaft with bearings, we have three main sections that are characterized by the appropriate diameter and length.

The previously defined dependencies and corresponding limitations for design variables to simplify mathematical calculations will be written in the following form, introducing the concept of the coefficient of structural calculation of the geometrical parameters of the shaft k :

- $(x_1 = d_1), \quad d_1;$
- $(x_2 = d_2), \quad d_2 = kd_1;$
- $(x_3 = l_1), \quad l_1 = k_1d_1;$
- $(x_4 = l_2), \quad l_2 = k_2d_2;$

- $(x_5 = B)$, $B = k_3 d_2$;
- $(x_6 = \rho)$, $\rho = \text{cons}$;
- $(x_7 = [\tau])$, $[\tau] = \text{cons}$;
- $(x_8 = T)$, $T = \text{cons}$.

In the given dependencies: k — coefficients of constructive conversion of diameter of the corresponding degree of a shaft, and k_i — coefficients of constructive conversion of the corresponding length of a section of a shaft.

Based on the above analysis of the parameters of the shaft of the mechanical transmission, the target function can be written in the form

$$m = f(x_1, x_2, x_3, x_4, x_5).$$

Based on the mathematical model, we obtain the equation to determine the mass of the shaft as the sum of the masses of the respective sections,

$$m_b = \sum_{i=1}^3 m_i = m_I + m_{II} + m_{III}.$$

The mass of i -section of the shaft is determined by the dependence

$$m_i = V_i \times \rho,$$

where: V_i — volume of i -section of the shaft; i — section's number.

Given that the shaft is made solid, the volume of this section of the shaft will be determined by the equation of volume of the cylinder

$$V_i = S_i \times l_i = \frac{1}{4} \pi \times d_i^2 \times l_i.$$

Since, according to the coefficient of constructive conversion of geometrical parameters of the shaft, the length of the i -th section of the shaft is written in the form

$$l_i = k_i \times d_i.$$

Thus, in general, the volume of i -section of the shaft will be determined by the following equation

$$V_i = \frac{1}{4} \pi \times d_i^2 \times k_i \times d_i = \frac{\pi}{4} k_i \times d_i^3,$$

and the volume of the shaft as a whole

$$V = \frac{\pi}{4} [k_1 d_1^3 + k_2 d_2^3 + k_3 d_3^3] = \frac{\pi}{4} [k_1 d_1^3 + k^3 (k_2 + k_3) d_1^3].$$

Given the above equations, we obtain the dependence for determining the mass of the shaft

$$m_b = \frac{\pi}{4} \rho [k_1 + k^3 (k_2 + k_3)] d_1^3 = \frac{\pi}{4} \rho \times K_b \times d_1^3,$$

where $K_b = k_1 + k^3 (k_2 + k_3)$ is the total coefficient of structural recalculation of the geometrical parameters of the shaft.

So

$$m_b = \frac{\pi}{4} \rho \times K_b \times d_1^3.$$

The analysis of the obtained equation indicates that the mass of the shaft in the first approximation can be estimated at the preliminary design stage, since only the initial diameter of the shaft is known from the design calculation. The difficulty of estimation is to determine the overall coefficient of constructive recalculation of the geometrical parameters of the shaft. To simplify the calculations, it is advisable to have tabular or graphical characteristics of the coefficient K , depending on the output shaft diameter.

According to the mathematical model of the shaft with bearings, determine the mass of the inner ring of the bearing

$$m_n = V_n \times \rho,$$

where the volume of the inner bearing ring is given by equation

$$V_n = \frac{1}{4} \pi \times D_0^2 \times B - \frac{1}{4} \pi \times d_2^2 \times B.$$

Taking into account the coefficient of structural recalculation of the geometrical parameters of the shaft, and also taking $D_0 = k_4 d_2$, we obtain the dependence for determining the mass of the bearing ring

$$m_n = \frac{\pi}{4} \rho (D_0^2 - d_2^2) B = \frac{\pi}{4} \rho \times K_n \times d_1^3,$$

where $K_n = k^3 (k_4^2 - k_3)$.

So

$$m_n = \frac{\pi}{4} \rho \times K_n \times d_1^3.$$

The total mass of the rotating element of the mathematical model of the shaft with bearings is determined by the following equation

$$m = \sum_{i=1}^2 m_i = m_b + m_n = \frac{\pi}{4} \rho \times K_b \times d_1^3 + \frac{\pi}{4} \rho \times K_n \times d_1^3 = \frac{\pi}{4} \rho \times K \times d_1^3,$$

where $K = K_b + K_n$, the total coefficient of structural recalculation of the geometric parameters of the rotating element of the model of the shaft with bearings. The number of bearings on the shaft must be taken into account. In this case, there are two of them, therefore $K_n = 2k^3 (k_4^2 - k_3)$.

Total dependency,

$$m = \frac{\pi}{4} \rho \times K \times d_1^3,$$

indicates that the mass of the rotating element of the model shaft with bearings in the first approximation can be estimated at the preliminary design stage, since the design calculation is known only the output diameter of the shaft. The complexity of the assessment is to determine the coefficient K , the value of which depends on the regulatory requirements and the relevant standards used in the design process of the assembly units of mechanical transmissions. Further studies will be directed to determine the nature of the $K (K_b, K_n)$ coefficient change depending on the output shaft diameter or other design parameters.

Conclusions

1. A mathematical model of the assembly unit of the mechanical transmission assembly unit was developed, on the basis of which dependencies were obtained for calculating the mass of a rotating element of a model of a shaft with bearings.

2. The introduction of the coefficient of structural recalculation of the geometrical parameters of the shaft and the overall coefficient of the structural recalculation of the geometric parameters of the rotating element of the model shaft with bearings make it possible to estimate the mass of the shaft or the mass of the rotating element in the first approximated at the stage of preliminary design, as from the design in order to stabilize the kinematic and dynamic characteristics of the machine unit without the use of additional masses.

3. The dependence of the mass of the rotating element of the shaft model with the bearings on the normative requirements and corresponding standards used in the design of the assembly units of mechanical gears has been established.

References

- [1] Gemintern V.N., & Kogan B.M. (1980) *Metody optimal'nogo proektirovaniya. [Methods of optimal design]*. Moscow: Energiia [In Russian].

- [2] Sobol I.M., & Statnikov R.B. (2006) *Vybor optimal'nyh parametrov v zadachah so mnogimi kriterijami* [Choosing the optimal parameters in problems with many criteria]. Moscow: Drofa [In Russian].
- [3] J. Genta. (1988) *Nakopiteli kineticheskoy energii. Teorija i praktika sovremennyh mahovichnyh system* [Aggregators kinetic energy here. Theory and practice of advanced flywheel systems] Moscow: Mir [In Russian].
- [4] Romaniuk A.D. (2010) Metod mnogokriterialnoy optimizatsii parametrov zubchatyih mehanizmov [Method of multicriteria optimization of gears parameters]. *Sbornik nauchnyh trudov Kerchenskogo gosudarstvennogo morskogo tehnologicheskogo universiteta "Mehanizacija proizvodstvennyh processov rybnogo hozjajstva, promyshlennyh i agrarnykh predpriyatij. Mehanika tverdogo tela."* – Collection of scientific works of the Kerch State Maritime Technological University "Mechanization of production processes in the fishing industry, industrial and agrarian enterprises. Mechanics of a solid body ", Issue 11, 81–85. [In Russian].
- [5] Romaniuk A.D. (2012) Opredelenie minimalnogo vremeni razgona mashinnogo agregata [Determination of the minimum time for the acceleration of the machine assembly] *Sbornik nauchnyh trudov Kerchenskogo gosudarstvennogo morskogo tehnologicheskogo universiteta i Dneprodzerzhinskogo gosudarstvennogo tehničeskogo universiteta "Mehanizacija proizvodstvennyh processov rybnogo hozjajstva, promyshlennyh i agrarnykh predpriyatij. Mehanika tverdogo tela."* – Collection of scientific works of Kerch State Maritime Technological University and Dneprodzerzhinsk State Technical University "Mechanization of production processes of fish industry, industrial and agrarian enterprises. Mechanics of a solid body ", Issue 13, 144–146 [In Russian].
- [6] Romaniuk A.D. (2013) Sintez peredatochnogo mehanizma optimalnogo po kriteriyu dinamichnosti [Synthesis of the transfer mechanism optimal by the criterion of dynamism] *Sbornik nauchnyh trudov Dneprodzerzhinskogo gosudarstvennogo tehničeskogo universiteta i Kerchenskogo gosudarstvennogo morskogo tehnologicheskogo universiteta "Mehanika tverdogo tela Mehanizacija proizvodstvennyh processov rybnogo hozjajstva, promyshlennyh i agrarnykh predpriyatij"* – Collection of scientific works of the Dneprodzerzhinsk State Technical University and the Kerch State Marine Technological University "Mechanics of the solid body. Mechanization of production processes in the fishing industry, industrial and agricultural enterprises. ", Issue 14, 20–23 [In Russian].
- [7] Romaniuk A.D. (2013) Osnovnyie podhodyi resheniya zadach sinteza peredatochnykh mehanizmov na osnove optimizatsii ego harakteristik [Basic approaches to solving the synthesis transmission's problems of the mechanisms based on optimization of its characteristics] *Sbornik nauchnyh trudov Dneprodzerzhinskogo gosudarstvennogo tehničeskogo universiteta i Kerchenskogo gosudarstvennogo morskogo tehnologicheskogo universiteta "Mehanika tverdogo tela Mehanizacija proizvodstvennyh processov rybnogo hozjajstva, promyshlennyh i agrarnykh predpriyatij"* – Collection of scientific works of the Dneprodzerzhinsk State Technical University and the Kerch State Marine Technological University "Mechanics of the solid body. Mechanization of production processes in the fishing industry, industrial and agricultural enterprises. ", Issue 14, 24–26 [In Russian].
- [8] Romaniuk A.D., & Mamaev L.M., & Kabakov A.M., & Telepko L.P. (2016) Optimizatsiya peredatochnoy funktsii mehanizma [Optimization of the transfer functions of the mechanism] *Materialy XII Mezhdunarodnoj nauchno-prakticheskoy konferencii "Aktual'nye nauchnye dostizhenija - 2016"* – Materials of the XII international scientific and practical conference "Actual scientific achievements - 2016". (Vol. 11), (pp.14–17). Praha: Publishing House «Education and Science» [In Russian].
- [9] Romaniuk O.D. (2015) Vybir mahovyh mas lanok peredatochnykh mehanizmiv na osnovi optymizacii' peredatochnoi' funktsii' [The choice of wing parts by weight of gear mechanisms based on optimizing the transfer function]. *Matematyčne Modeliuvannia –Mathematical modeling*, 2(33), 52–54 [in Ukrainian].
- [10] Romaniuk O.D. (2015) Optymizacija mas zubchastyh kolis mehanichnoi' peredachi na etapi poperedn'ogo proektuvannja [Optimization of the masses of gears mechanical transmission during

the preliminary design]. *Matematychni Modeliuvannia –Mathematical modeling*, 2(35), 35–38 [in Ukrainian].

- [11] Romaniuk O.D. (2018) Rozrobka matematy`chnoyi modeli obertal`ny`x vuzliv mexanichnoyi peredachi [Basic approaches to mass optimization of toothed wheels of mechanical transmission]. *Matematychni Modeliuvannia –Mathematical Modeling*, 1(38), 118–123 [in Ukrainian].

РОЗРОБКА МАТЕМАТИЧНОЇ МОДЕЛІ ОБЕРТАЛЬНИХ ВУЗЛІВ МЕХАНІЧНОЇ ПЕРЕДАЧІ

Романюк О.Д.

Реферат

При проектуванні приводу виконавчого органу машинного агрегату виникає необхідність зменшення амплітуди коливань швидкості ланки зведення, яка в основному вирішується способом використання додаткових махових мас, що збільшує вагу механізму та його інерційність. Щоб уникнути відповідних недоліків доцільніше проектувати нові передаточні механізми моменти інерції обертальних мас яких могли б виконувати функцію маховика.

При вирішенні поставленої проблеми необхідно підібрати на стадії попереднього проектування відповідну масу обертального вузла механічної передачі, яка б відповідала маховому моменту маховика. Задачі проектування механічних передач з урахуванням оптимізації кінематичних та силових характеристик приводу виконавчого органу машинного агрегату являються багатокритеріальними, так як виникає необхідність враховувати взаємно залежні параметри, особливо при розробці математичної моделі елементів складального вузла механічної передачі.

Особливістю проектування складальної одиниці вузла обертання механічної передачі при умові її оптимізації полягає в тому, що кількість невідомих величин проектування набагато більше ніж рівнянь зв'язку, що суттєво ускладнює і без того багатоваріантність задачі. Тому розглядається задача зменшення числа невідомих, а також встановлення впливу відповідних параметрів на характер зміни маси складальної одиниці, згідно якої було зменшено кількість перемінних величин з восьми до п'яти та вибрані обмеження для перемінних величин проектування.

Розроблена математична модель складальної одиниці вузла обертання механічної передачі на основі якої отримано залежності для розрахунку маси валу з підшипниками. Введення коефіцієнта конструктивного перерахунку геометричних параметрів валу та загального коефіцієнта конструктивного перерахунку геометричних параметрів обертального елемента моделі валу з підшипниками дають можливість оцінити масу валу чи масу обертального елемента в першому наближенні на етапі попереднього проектування, так як із проектного розрахунку відомо тільки вихідний діаметр валу.

Встановлено залежність маси обертального елемента моделі валу з підшипниками від нормативних вимог та відповідних стандартів які використовуються в процесі проектування складальних одиниць механічних передач з метою стабілізації кінематичних та динамічних характеристик машинного агрегату без використання додаткових мас.

Література

1. Геминтерн В. Н., Коган Б. М. Методы оптимального проектирования: М.: Энергия, 1980. 160 с.
2. Соболев И.М., Статников Р. Б. Выбор оптимальных параметров в задачах со многими критериями: М.: Дрофа, 2006. 175 с.
3. Дженга Дж. Накопители кинетической энергии. Теория и практика современных маховичных систем: М.: Мир, 1988. 430 с.

4. Механизация производственных процессов рыбного хозяйства, промышленных и аграрных предприятий: сб. науч. тр. / редкол.: Е. П. Масюткин (глав. ред.). Керчь: Выд-во КГМТУ, 2010. Вып. 11. 196 с.
5. Механизация производственных процессов рыбного хозяйства, промышленных и аграрных предприятий. Механика твердого тела: сб. науч. тр. / редкол.: Е. П. Масюткин (глав. ред.). Керчь-Днепродзержинск: Выд-во ДГТУ, 2012. Вып. 13. 201 с.
6. Механика твердого тела. Механизация производственных процессов рыбного хозяйства, промышленных и аграрных предприятий: сб. науч. тр. / редкол.: Е. П. Масюткин (глав. ред.). Днепродзержинск-Керчь: Выд-во ДГТУ, 2013. Вып. 14. 144 с.
7. Механика твердого тела. Механизация производственных процессов рыбного хозяйства, промышленных и аграрных предприятий: сб. науч. тр. / редкол.: Е. П. Масюткин (глав. ред.). Днепродзержинск-Керчь: Выд-во ДГТУ, 2013. Вып. 14. 144 с.
8. Aktualni vedecke vymozenosti – 2016. Оптимизация передаточной функции механизма: materialy XII mezinarod. vedecko-prakt. konf., Praha, 22–30 cervna 2016.r./ Education and Science, sefred. Z. Crnak. Praha: Education and Science, 2016. 120. s.
9. Математичне моделювання: зб. наук. пр. / М–во освіти і науки України, Дніпродзержинський державний технічний університет, голов. ред. С. Є. Самохвалов. Дніпродзержинськ, 2015. Вип. 2(33) 140 с.
10. Математичне моделювання: зб. наук. пр. / М–во освіти і науки України, Дніпровський державний технічний університет, голов. ред. С. Є. Самохвалов. Кам'янське, 2016. Вип. 2(35) 135 с.
11. Математичне моделювання: зб. наук. пр. / М–во освіти і науки України, Дніпровський державний технічний університет, голов. ред. Б. П. Середа. Кам'янське, 2018. Вип. 1(38) 223 с.