

**Purpose.** To develop intelligent information technology for processing visual information for the metals state diagnostics. As against the already existing technologies it will allow diagnosing the state of metal by all characteristics (chemical composition, structure, properties).

**Methodology.** The methods of comparative study, scientific abstraction and mathematical simulation have been used in the study.

**Findings.** The basic stages of the intelligent information technology have been described. The neural networks choice to solve the problem of automation metallographic analysis at all its stages has been substantiated. The neural networks results for metallographic images recognition to determine quantitative information about metal have been shown. The neural network results to determine the metals properties by samples of steel of different grades have been described.

**Originality.** We have developed the intelligent information technology of visual information processing for the metals state diagnostics based on the neural networks and the precedents theory. It can diagnose the metals state by all its characteristics (chemical composition, structure, properties).

**Practical value.** Scientific results of the work allowed us to develop the intelligent information technology of the visual information processing for determination of metals properties. The software which implements the methods and the stages of the developed information technology have been created.

**Keywords:** *information technology, metallographic analysis, neural network, software, image processing, precedents method*

*Рекомендовано до публікації докт. техн. наук  
А.І. Песчанським. Дата надходження рукопису 15.08.13.*

УДК 621.72:004.724.4

**Ye.I. Kucherenko, Dr. Sci. (Tech.), Professor,  
S.M. Trokhymchuk**

Kharkiv National University of Radio Electronics, Kharkiv,  
Ukraine, e-mail: serge\_nick@mail.ru

## MODELS OF PROCESSES IN TECHNOLOGIES OF INDUSTRIAL SYSTEMS QUALITY CONTROL

**Є.І. Кучеренко, д-р техн. наук, проф.,  
С.М. Трохимчук**

Харківський національний університет радіоелектроніки,  
м.Харків, Україна, e-mail: serge\_nick@mail.ru

## МОДЕЛІ ПРОЦЕСІВ У ТЕХНОЛОГІЯХ УПРАВЛІННЯ ЯКІСТЮ ВИРОБНИЧИХ СИСТЕМ

**Purpose.** To rise quality of products based on the proposed methods and models of processes control.

**Methodology.** The assessment of model quality has been carried out experimentally in a production environment. The experiment has proved the effectiveness of the approaches and production quality of energy intensive products.

**Findings.** We have upgraded the process models with modules of adaptation and realization of adaptation functions and system components testing to raise the operation quality of the object. We have suggested a new method of implementation of processes of quality control in compound systems. It is characterized by complexity which is close to quadratic. Optimization of the decisions, based on minimization of the criteria proposed and subject restrictions, allows us to minimize the number of defective products. Practical aspects of technological objects modeling have been investigated; the effectiveness of suggested approaches has been confirmed. Critical analysis of possible solutions has shown that we can consider a modified analysis of the solutions synthesis aiming the product quality improvement retaining its cost and quantity.

**Originality.** Based on the substantial analysis of the solutions currently in use we have suggested new approaches to the model optimization and development considering the indices and restrictions of the subject field in order to raise the production quality at the facility under consideration.

**Practical value.** The practical aspects of technological objects have been studied. The effectiveness of the approach suggested has been confirmed. The prospects for further research in the field of improvement of production facilities have been considered. The study shows that the most important factor affecting the efficiency of the processing equipment is reliability and its derivatives. In this regard, the factors maximizing the reliability are of particular interest for models development and their practical application.

**Keywords:** *quality model, process control, production, optimization*

**Introduction.** Process control in industrial automated systems is usually characterized by some important aspects. Among them, in the first place, there are properties of industry performance effectiveness [1]:

- equipment utilization

$$K_m = \sum_{i=1}^M \sum_{j=1}^n t_M / \sum_{i=1}^M \sum_{j=1}^n t_{po}, \quad (1)$$

where  $M$  – a number of part names in the set;  $n$  – a number of machine- tool operations for one part;  $t_M$  and  $t_{po}$  – machine time and piece-operating time for an operation respectively;

- shift utilization of equipment work

$$K_{su} = n_{cc} / (n_{yo} D_p), \quad (2)$$

where  $n_{cc}$  – a number of worked machine-tool shifts in a month;  $n_{yo}$  – a number of installed pieces of equipment;  $D_p$  – a number of working days in a month.

The determinant factors of mechanical engineering equipment operating are indices of reliability. They are:

- mean time between failures

$$T_o = \frac{N}{\sum_{i=1}^N t_i} / m, \quad (3)$$

where  $N$  – a number of equipment pieces included to industrial system;  $t_i$  – time between failures for an hour of  $i$ -equipment working;  $m$  – a number of equipment failures from  $N$  machine- tools ;

- maintainability of equipment ready to work

$$K_m = T_o / (T_o + k_p T_r), \quad (4)$$

where  $k_p(\mu) = 1/k'$  – index of professional suitability of personnel,  $k' = (0,1]$ ;  $T_r$  – time for repairing a failure (elimination of defects);

- index of reparability

$$T_r = \sum_{i=1}^N \tau_i / N, \quad (5)$$

where  $\tau_i$  – average time for  $i$ -equipment repairing.

Indices (1)–(5), as well as indices of effectiveness [1], determine effectiveness of technological section operation.

As investigations have shown, the most important factors which influence the effectiveness of technological equipment are indices of reliability (2)–(5) and their derivatives. In this connection, maximization of reliability factors is of great interest for development of models [2, 3].

**Statement of the research problem.** The structure of hybrid model of automated technological section [3] is given in the form

$$S_p = \bigcup_{\Omega} S_{\omega}, \omega \in \Omega. \quad (6)$$

As it has been noted in the work [3], symbol  $\bigcup_{\Omega}$  in (6) determines some functionality in a set of relations  $R^{(O)}(x, y)$  model component  $S_{\omega}$ . Some properties of effectiveness are also determined from (1)–(5).

It is necessary to suggest approaches to optimization and model development (6) on the basis of indices (1)–(5) for raising effectiveness of the article quality.

**Basic material. Hybrid model development in practical realizations.** The most important aspect of the rational model utilization in industrial process control is to take into account object indices, interferences and minimization of influence made by reliability indices of system component on the final product.

In the work [4], the structure of hybrid model suggested with some simplifications, has a form (fig.1) and realizes control in the form

$$\hat{X} \rightarrow \hat{Y}. \quad (7)$$

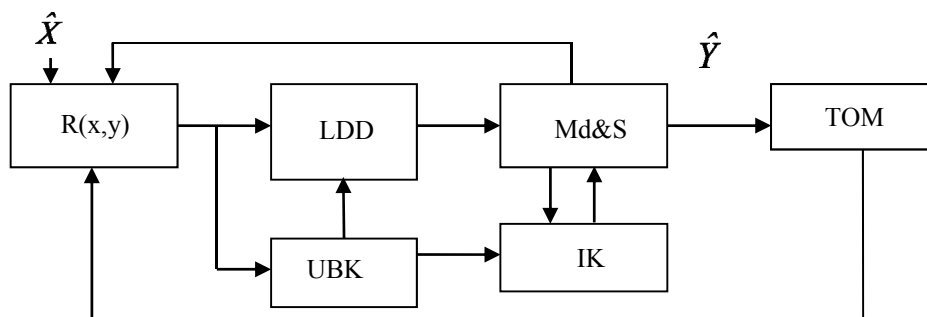

Fig. 1. Model structure containing : a great number of relations on the cartesian products of relational model of data(MD); LDD – a logical device of design; UBK – a model of fuzzy base of knowledge; IK – an interpreter of knowledge; Md&S – the module of modification of data and knowledge; TOM – a technological object of management

As substantial model analysis (fig.1) [3] has shown, its modules realize control (7) not to the full extent under

conditions of acting disturbances and great intensity of system component failures.

**Statement 1.** If model  $S_p = \bigcup_{\Omega} S_{\omega}$ ,  $\omega \in \Omega$ , which realizes control  $\hat{X} \rightarrow \hat{Y}$ , then additional putting into operation the adaptation module according to reliability criterion (MA) and the module of testing realization and presentation of adaption processes (MT&A) allows to raise the quality of manufactured articles.

Indeed, correctness of statement 1 is evident if we take into account response of the system and model (6) to interferences and factors reducing level of article defects which is realized by module (MT&A) and formation of vector  $\hat{Y}(M)$ .

So, the structure of a model (6) can be presented in fig. 2.

Having marked modules MA and MT&A in the form

$$S_{\alpha} = \cup(S_M, S_{MT}). \quad (8)$$

We can present hybrid model development as a composition of particular models (6) and (8)

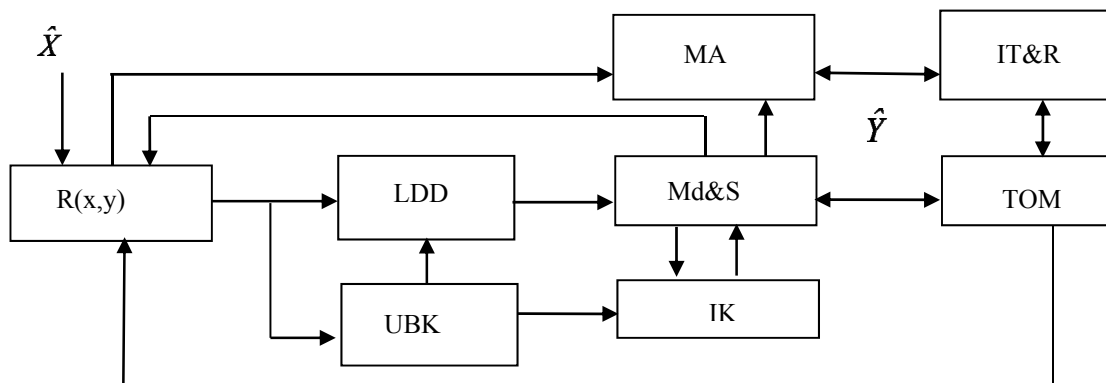

Fig. 2. Structure of a new model, additionally including the modules: MA – the module of adaptation on the criterion of reliability; IT&R – the implementation of testing and reflection of adaptation processes module

Let us determine system reliability factors which are mathematically analyzed in works [2,4]. The technological object of control (TOM), as an object of investigation, is characterized by the following parameters:

- an object is a composition of instrument making soft and hardware as well as articles of mechanical engineering;
- sequential system is characterized by [4] the fact that failure of at least one element leads to failure of the whole system. Occasional time of sequences consisting of independent elements is determined by

$$X = \min(X_1, X_2, \dots, X_n); \quad (11)$$

- processes are characterized by some distributed probability of no failure operation [4];

- let us assume that random quantity X is exponentially distributed while functioning of a section with parameter  $\alpha$  and is determined in the form

$$S_{p\alpha} = \bigcup_{\Omega} (\cup S_{\omega} \cup (S_M, S_{MT})), \omega \in \Omega. \quad (9)$$

Problems of composition unification in (9) are important and topical and they demand further investigations. So the problems of models synthesis and quality raising systems of complex objects on the basis of reliability control of model component [3, 5] are of great interest.

**Synthesis of models on the basis of reliability indices optimization for complex objects.** The purpose of system synthesis, with indices optimization factor on the basis of cost indices C of their functioning minimization is determined from the functional in the form

$$\sum_{\eta}^N C_{\eta} (C_{\eta} \in C) | P(t) \geq P(t)^* = true, \eta \in N, \quad (10)$$

where  $P(t)^*$  – acceptable value of operational reliability.

$$P(t) = 1 - e^{-\alpha t}, t \geq 0, \alpha > 0. \quad (12)$$

**Statement 2.** If we assume as a parameter  $\alpha$  the quantity of failure intensity  $\lambda$ , then random quantity (12) can be given in the form

$$P(t) = 1 - e^{-\lambda t}, t \geq 0, \lambda > 0, \quad (13)$$

where parameter  $\lambda$  in (13) determines Gaussian steepness. Parameter  $\lambda$  is determined on the basis of the object functioning statistics.

Correctness of statement 2 directly results from the nature of parameter  $\lambda$  and reliability indices (10)–(11).

**Remark 1.** Distribution of time in technically substantiated cases can be given in the form of some alternatives [5].

At present, n algorithms on the basis of SS minimum identification error criterion have been developed in practical realization

$$J_t^i = \sum_{i=1}^t \alpha(i) V_x^2(i) \quad (14)$$

taking into account the necessity of elimination or modification of outdated information, the approach (14) is modified as

$$J_t^i = \sum_{i=1}^t e^{t-i} V_x^2(t), \quad (15)$$

where  $0 \leq \alpha \leq t$  – a discounting parameter of outdated information.

As appears from [5], least-squares method (14)–(15) in adaptive control systems raises a number of complications because of strong input correlation in calculating inverse matrix which determines bad causality.

So the task of synthesis according to reliability criteria results in practical directivity. Critical analysis of possible decisions has shown that the following analysis of decision synthesis directed to raising production quality with simultaneous conservation of cost and quantitative indices can be considered. Then, as a quality criterion for the task of object parameter synthesis, we can take functional  $I$ , which determines no failure operation of the given object with certain restrictions

$$\begin{aligned} I &= \min(X_1, X_2, \dots, X_n) / P(\kappa) \in \{P(k)\}; \\ P(t) &\geq P(t)^*; \\ \sum_{\eta=1}^N C\eta (C\eta \in C), \eta \in C, N &\geq N^*. \end{aligned} \quad (16)$$

In some cases (16), it can also be presented in the form (4), as

$$\begin{aligned} T_o / (T_o + k_p T_e) &\rightarrow \max; \quad (17) \\ P(\kappa) &\in \{P(k)\}, P(t) \geq P(t)^*; \\ \sum_{\eta=1}^N C\eta (C\eta \in C), \eta \in C, N &\geq N^*; \\ \tau &\leq \tau^* \end{aligned}$$

at multitude of restrictions (16).

Having alternatives  $\{Alt_\nu\}, \nu \in N$ , in solution (16), (17) we should take into consideration the search

$$\{Alt\}_Y = \min_F \{Alt_\nu\}, \nu \in N, Y \subseteq N \quad (18)$$

as subset from  $Y \subseteq N$  of possible solutions.

The structure of the developed method which defines the main cause-effect relations in its realization is presented in fig. 3.

Taking into consideration (16)–(18), we can formulate the stages of the realized method.

Stage 1. Determine the model structure and distribution function of probabilities for the system components

Stage 2. Formulate a set of reliability indices for the analyzed section component.

Stage 3. Determine the level (intensity) of defective articles.

Stage 4. Determine the set of the system cost indices.

Stage 5. Set standards of the accepted values according to criteria  $C_\eta, N$  and  $P(k)$ .

Stage 6. For a case when  $-(C_\eta, N, P(k)) \rightarrow false$  is disturbed, we undertake testing and failures elimination procedures with their consequences, under possible restrictions.

Stage 7. Repeat stages 1–6 until realization of criteria (16)–(18) under restrictions as for time resources  $\tau \leq \tau^*$ .

Stage 8. Stop.

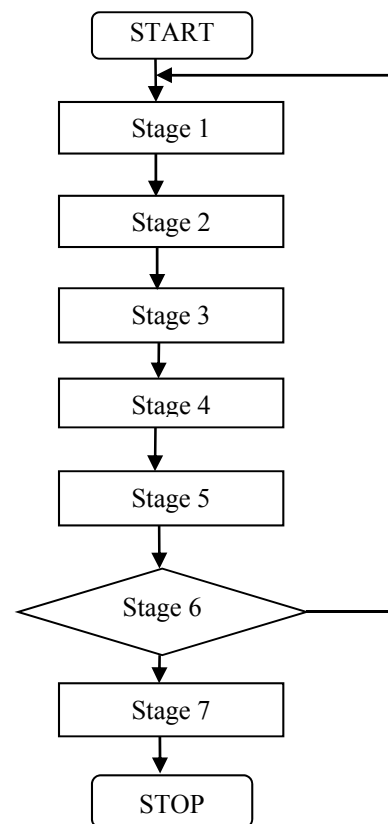

Fig. 3. Structure of the developed method: Start – Starting up procedures of the method realization; Stop – Stopping procedures of the method realization; 1 – 7 – method stages

As it follows from peculiarities of technological process realization at a certain section, computational complexity of processes realization is in many ways determined by a model on the basis of particular models by Petri nets extensions [5]. Lower limit of computational complexity  $O$  of the developed method (fig. 3) can be presented as the second order polynomial

$$O = a_0 + a_1x + a_2x^2, \quad (19)$$

where  $a_0, a_1, a_2$  – some indices, identification (19) is realized and improved on the basis of algorithm realization taking into account processor parameters of computing facilities. Correctness (19) is confirmed by the experiment.

**Practical realization.** During the industrial process of mechanical assembly production at highly automated enterprises, the final operations take considerable volume of output, that is why the state of the appropriate instruments and equipment is of great significance.

At present, industrial assembly sections of mechanical engineering enterprises have a modern production base which includes round grinding machines with NC of foreign and home production fitted with active control systems, giving an opportunity to exercise monitoring and control of a technological process. The scheme of industrial installation includes highly automated equipment with inductive transducer and electronic measuring system with  $-0.01; 0.1 \mu\text{m}$  and error  $<0.5\%$ .

Application of terms of linguistic variables as a membership function  $k_p(\mu) = \mu(x)$  in coordinates “fuzzy argument – membership function value” (fig. 4) allows to decide procedures of fuzzy inferencing on UBK

$$Y' = \vee X' \wedge \mu(x, y), \quad (20)$$

where  $\vee, \wedge$  – operators, accordingly of maximum and minimum in (20);  $X, Y, \mu(x, y)$  – values accordingly of argument vector, sought after vector, fuzzy relation of membership functions.

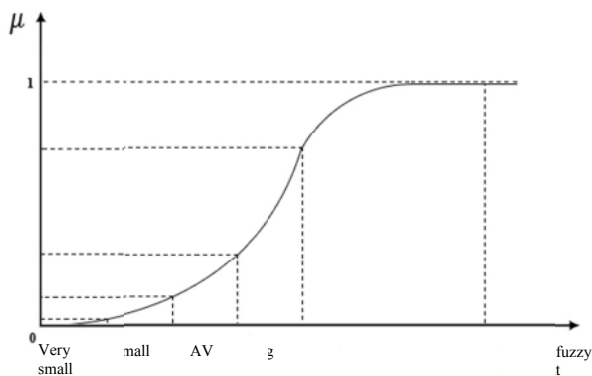

Fig. 4. Term of membership function  $k_p(\mu)$  in coordinates “fuzzy argument – membership function value”

In the process, we proposed the term linguistic variable “large”, which can be represented as an analytical application in the form of

$$k_p(\mu) = 1 - \exp(-k(x - a)^2),$$

where  $k$  – steepness of function,  $k > 0$ ;  $a$  – displacement of function  $a \geq x$ .

Here  $k$  – the elements of term tuning of a linguistic variable (fig. 4)

The terms of function in fig. 4 have experimental gradation: “very small”, “small”, “AV”, “large”, “very large”.

Following the defect system can lead to heavy material losses and affect cost  $C$  of the finished product. Application of the developed method (fig. 3, stages 1–7) with solution of optimization tasks (16)–(17) allows for a set of alternatives (18) to reduce the time for exposure, localization and elimination of failure reasons, in linguistic terms of professional suitability of medium-level repair personnel (fig. 4), to  $\tau \leq 20 \text{ min.}$ , which is a satisfactory result.

#### Conclusions.

1. Substantial analysis of the given solutions and approaches to optimization and model development with indices and restrictions in the subject field for raising effectiveness of the article quality at a given facility are presented.

2. Process models have gained the further development. In contrast to existing models they include adaptation modules and realization of adaptation functions and system component testing, all which raises object functioning quality.

3. A new method for realizing control processes over article quality is suggested in compound systems. It is characterized by complexity which is close to quadratic.

4. Practical aspects of technological objects realization have been investigated; effectiveness of the suggested approaches has been confirmed.

5. Perspectives of further research into improving industrial facilities of the subject fields have been considered.

#### References / Список літератури

1. Glushenkova, I.S. (2011), “Applied aspects of implementation of methods and information technologies of estimation of complex facilities”, *Vostochno-Yevropeiskiy Zhurnal Peredovykh Tekhnologiy*, no.3/9 (51), pp. 35–38.

Глушенкова И.С. Прикладные аспекты реализации методов и информационных технологий оценивания сложных объектов / И.С. Глушенкова // Восточно-Европейский журнал передовых технологий. – 2011. – № 3/9 (51). – С. 35–38.

2. Borovikov, S.M. (2006), “Forecasting Method of Reliability of Electronic Engineering Production”, *Reports of the National Academy of Sciences of Belorussia*, T.50, no.4, pp. 105–109.

Метод прогнозирования надежности изделий электронной техники / С.М. Боровиков [и др.] // Доклады НАН Беларуси. – 2006. – Т.50. – №4. – С. 105–109.

3. Kucherenko, Ye.I. and Trokhymchuk, S.N. (2013), “Hybrid Models and Information Technologies at Complex Facilities Management”, *Kompiuterno-Intehrovani Tekhnologii: Osvita, Nauka, Vyrobnystvo*, Lutsk National Technical University, pp. 46–51.

Кучеренко Е.И. Гибридные модели и информационные технологии в управлении сложными объектами / Е.И. Кучеренко, С.Н. Трохимчук // Комп'ютерно-інтегровані технології: освіта, наука, виробництво. – 2013. – С. 46–51.

4. Shubin, R.A. (2012), *Nadezhnost tekhnicheskikh sistem i tekhnogennyi risk* [Reliability of Engineering Sys-

tems and Anthropogenic Risk], VPO TGTU, Tambov, Russia.

Шубин Р.А. Надежность технических систем и техногенный риск / Шубин Р.А. – Тамбов: ВПО ТГТУ, 2012. – 80с.

5. Bodyanskiy, Ye.V., Mikhalev, A.I. and Filatov, V.A. (2008), *Neuro-fuzzy modeli i multiagentnye tekhnologii v slozhnykh sistemakh* [Neuro-fuzzy Models and Multiagent Technologies at Complex Systems], Systemni tekhnologii, Dnepropetrovsk, Ukraine.

Бодянский Е. В. Нейро-фаззи модели и мультиагентные технологии в сложных системах / Бодянский Е.В., Михалев А.И., Филатов В.А. – Днепропетровск: Системні технології, 2008. – 412с.

**Цель.** Повышение качества изделий производства на основе использования методов и моделей управления процессами.

**Методика.** Оценка качества модели определена экспериментально в условиях производства. Экспериментом подтверждена эффективность подходов и качество выпуска энергозатратных продуктов.

**Результаты.** На основе содержательного анализа существующих решений предложены новые подходы к оптимизации и развитию модели с учетом показателей и ограничений предметной области для повышения эффективности качества изделий данного объекта. Получили дальнейшее развитие модели процессов, которые, в отличие от существующих, дополнительно включают модули адаптации и реализации функций адаптации и тестирования компонент системы, что повышает качество функционирования объектов. Предложен новый метод реализации процессов управления качеством изделий в сложных системах, который характеризуется сложностью, близкой к квадратичной. Оптимизация решений на основе минимизации предложенных критериев и ограничений предметной области позволяет минимизировать количество бракованных изделий. Исследованы практические аспекты реализации моделирования технологических объектов, подтверждена эффективность предложенных подходов. Критический анализ возможных решений показал, что может быть рассмотрен модифицированный анализ синтеза решений, направленных на повышение качества продукции при одновременном сохранении ценовых и количественных показателей.

**Научная новизна.** На основе содержательного анализа существующих решений предложены подходы к оптимизации и развитию модели с учетом показателей и ограничений предметной области для целей повышения эффективности качества изделий рассматриваемого объекта.

**Практическая значимость.** Исследованы практические аспекты реализации технологических объектов, подтверждена эффективность выбранных подходов. Рассмотрены перспективы дальнейших исследований в области совершенствования производственных объектов предметных областей. Как показали исследования, самым важным условием, влияющим на эффективность

технологического оборудования, являются показатели надежности и их производные. В связи с этим максимизация условий надежности представляет особенный интерес в части развития моделей и их практического использования.

**Ключевые слова:** модель качества, процесс, управление, производство, оптимизация

**Мета.** Підвищення якості виробів виробництва на основі використання методів та моделей управління процесами

**Методика.** Оцінка якості моделі визначена експериментально в умовах виробництва. Експериментом підтверджена ефективність підходів та якість випуску енергозатратних виробів.

**Результати.** На основі змістовного аналізу існуючих рішень запропоновані нові підходи до оптимізації та розвитку моделі з урахуванням показників і обмежень предметної області для цілей підвищення ефективності якості виробів даного об'єкту. Отримали подальший розвиток моделі процесів, що, на відміну від існуючих, додатково включають модулі адаптації та реалізації функцій адаптації й тестування компонент системи, що підвищує якість функціонування об'єктів. Запропонований новий метод реалізації процесів управління якістю виробів у складних системах, що характеризується складністю, близькою до квадратичної. Оптимізація рішень на основі мінімізації пропонує критеріїв і обмежень предметної області дозволяє мінімізувати кількість бракованих виробів. Досліджені практичні аспекти реалізації моделювання технологічних об'єктів, підтверджена ефективність пропонує підходів. Критичний аналіз можливих рішень показав, що може бути розглянутий модифікований аналіз синтезу рішень, спрямованих на підвищення якості продукції при одночасному збереженні вартісних і кількісних показників.

**Наукова новизна.** На основі змістовного аналізу існуючих рішень запропоновані нові підходи до оптимізації та розвитку моделі з урахуванням показників та межі предметної області для цілей підвищення ефективності якості виробів об'єкта, що розглядається.

**Практична значимість.** Досліджені практичні аспекти реалізації технологічних об'єктів, підтверджена ефективність обраних підходів. Розглянуті перспективи подальших досліджень в області вдосконалення виробничих об'єктів предметних областей. Як показали дослідження, найважливішим чинником, що впливає на ефективність технологічного устаткування, є показники надійності та їх похідні. У зв'язку з цим максимізація чинників надійності представляє особливий інтерес у сенсі розвитку моделей і їх практичного застосування.

**Ключові слова:** модель якості, процес, управління, виробництво, оптимізація

*Рекомендовано до публікації докт. техн. наук В.О. Філатовим. Дата надходження рукопису 22.08.13.*