

UDC 621.926.34:622.7

V.V. Povetkin, Dr. Sci. (Tech.), Professor,
O.A. Sushkova, Cand. Sci. (Tech.),
Z.A. Ibragimova, Zh.K. Shukhanova, A.E. Assan

K.I. Satpayev Kazakh National Technical University, Almaty,
Kazakhstan, e-mail: zaure_1983_as@mail.ru

DETERMINATION OF STIFFNESS OF STRUCTURAL ELEMENTS DRIVE BALL MILL

В.В. Поветкін, д-р техн. наук, проф.,
О.А. Сушкова, канд. техн. наук,
З.А. Ібрагімова, Ж.К. Шуханова, А.Е. Ассан

Казахський національний технічний університет ім. К. Сат-
паєва, м.Алмати, Казахстан, е-mail: zaure_1983_as@mail.ru

ВИЗНАЧЕННЯ ЖОРСТКОСТІ КОНСТРУКТИВНИХ ЕЛЕМЕНТІВ ПРИВОДУ КУЛЬОВОГО МЛИНА

Purpose. To define the rigidity of tooth gearings, shaft, and couplings connected in one kinematic sequence in ball mill drive.

Methodology. The important stage of preparation of the rated diagram of electromechanical system is the definition of its parameters. The parameters of electric motors can be accepted under catalogues but instants of inertia, rigidity of transfers and other parameters are subject to calculation.

Findings. We have determined the analytical parameters allowing us to define the rigidity of gear gearings, rigidity of shaft drive and rigidity of elastic coupling, shaft drive of drums of spherical mills connecting the ends.

Originality. To determine the rigidity of constructive elements involved into the rated diagram of electromechanical system of the drive of spherical mill, we have chosen the rated dynamic model executed in the form of two-mass electromechanical system which contains two concentrated inertial weights connected by one elastic viscous connection of the engine rotor and working body of the machine.

Practical Value. Gear gearings of the spherical mill and the operating forces deforming teeth and connecting elastic deformations have been considered. The offered procedure allows defining the rigidity of the elements entering a kinematic circuit of any electromechanical systems of drives and choosing their design data in the future.

Keywords: *ball mill, gears mesh, springiness, hardness, inertia, drive, clutch*

Introduction. The problem of drawing up calculating dynamic models of various production mechanisms and cars with the adjustable electric drive, including the drive of the working body of the technical car with a big moment of inertia, is extremely actual under the conditions of a growing number of new constructive decisions [1]. As a rule, calculating model represents two-mass electromechanical system which contains two concentrated inertial masses connected by one elastic viscose connection. One concentrated inertial weight acts as an engine rotor, and the other – as a working body of the car [2].

The main function which characterizes dynamic behavior of the system is the period of the induced excitement in gearing with variable rigidity. This phenomenon is a consequence of change of quantity of the teeth couple connected at the same time that is a function of the angular situation in gearing [3].

Theoretical prerequisites. While drawing up physical models of machine units to research dynamic processes proceeding in them, they are usually represented in the form of system with the concentrated inertial parameters in which the engine rotor, separate parts of the drive, for example,

wheels, connecting couplings, etc., and also working part of the machine unit are represented in the form of material bodies and the points possessing a certain masses, the sizes and the inertia moments. Idealized connections between them do not possess weight, but have elastic and dissipative characteristics [4].

According to calculating schemes of mills (fig. 1). all constructive elements of their drive, from the electric motor to the drum, are presented by cylindrical tooth gearings, shafts in the support of swing connected by couplings, with axes of rotation parallel to the axis of rotation of the drum. By drawing up dynamic models of spherical mills, we will consider elastic properties (rigidity) of tooth gearings of the drive of the drum, shafts and couplings connecting them; and as resistance forces the moments of friction of the drum sliding support, and also the moments of inertia of forces concerning axes of rotation [5].

In order to consider elasticity (rigidity) of constructive elements of the drum drive, we will define rigidity of tooth gearings, shafts and the couplings connected consistently in one kinematic chain.

In operating time of mills in gear gearings of wreath 1 on the drum I and a driving gear wheel 2 (II), (as well as in gear gearing of wheels of reducer, in the scheme in fig. 2) forces given by them come into action deforming the teeth.

© Поветкін В.В., Сушкова О.А., Ібрагімова З.А., Шуханова Ж.К.,
Ассан А.Е., 2014

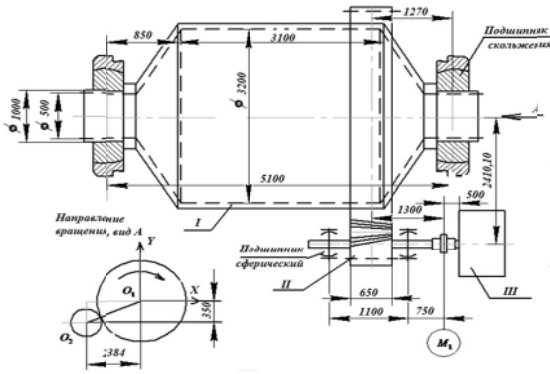

Fig. 1. Constructive and kinematic scheme of the spherical mill with the gear wreath on the drum and the gearless electric drive: I – drum with the gear wreath $z_K = 278$; II – shaft driving with a gear wheel $z_{II} = 22$; III – the electric motor synchronous $n_\phi = 250$ cap/min; M_1 – the coupling connecting

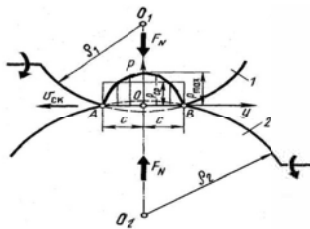

Fig. 2. Calculating model to determination of pressure in the contact zone of two elastic cylinders

Statement of the main material. We will consider one of the components of this force P_t directed at the tangent to initial circles of transfer cogwheels (fig. 2), as well as the component of small elastic deformation of teeth in the same direction S_t .

Force P_t and elastic deformation S_t are connected by the ratio

$$P_t = c \cdot S_t, \quad (1)$$

where c is linear rigidity of gear gearing, which is proportional to the length of teeth B (wreath width) and is determined by the formula

$$c = a \cdot B. \quad (2)$$

Here a is a coefficient which is accepted equal = $15 \cdot 10^3$, MPa for steel wheels [2].

In order to come down from small linear movement S_t to angular one $\Delta\varphi$, we will fix unmovable gear wheel 2, and we will put the moment $M_1 = (M_1, M_c)$ to the wreath drum 1. Under its influence the teeth of wheels are deformed and the wreath 1 will turn to the small corner

$$\Delta\varphi_1 = \frac{S_t}{r_1},$$

from which $M_2 = c_{21} \Delta\varphi_2$,

$$S_t = \Delta\varphi_1 \cdot r_1. \quad (3)$$

Here r_1 is the radius of the initial circle of the wheel 1.

Here in $P_t = \frac{M_1}{r_1}$.

Substituting the received expressions in equality (1), we will have

$$M_1 = c \cdot r_1^2 \Delta\varphi_1$$

or

$$M_1 = c_{12} \Delta\varphi_1,$$

where the angular rigidity of gear gearing given to the wreath 1, at not movably fixed gear wheel, is determined by formula.

$$c_{12} = c \cdot r_1^2. \quad (4)$$

Similarly, with the wreath 1 fixed,

$$S_t = \Delta\varphi_2 \cdot r_2, \quad (5)$$

where r_2 is the radius of the initial circle of the gear wheel 2. If the moment is put to the gear wheel 2

$$M_2 = M_1 u_{21},$$

it will turn on the small corner. $\Delta\varphi_2$.

Thus, $P_t = \frac{M_1}{r_1}$,

where

$$c_{21} = c \cdot r_2^2 \quad (6)$$

is the angular rigidity of gear gearing given to the gear wheel 2, at the motionless wreath 1. Then,

$$c_{21} \neq c_{12},$$

since from equality of expressions (3) and (5) it follows

$$\Delta\varphi_1 \cdot r_1 = \Delta\varphi_2 \cdot r_2;$$

$$c_{21} = c \cdot r_1^2 \left(\frac{r_2}{r_1} \right)^2 = c_{12} u_{12}^2.$$

Thus,

$$c_{21} = c_{12} u_{21}^2, \quad (7)$$

where $u_{21} = \frac{r_2}{r_1} = \frac{z_2}{z_1}$ is the transfer relation of wheels 2 and 1.

Following the stated technique, we find rigidity of gear gearing of wheels of a reducer in the scheme of the drive drum of mill according to fig. 3 for which, according to formulas (1)–(7), we will have

$$P_t' = c \cdot S_t'.$$

Here $c = aB'$, B' is the width of the wreath of wheels 3 and 4

$$S'_t = \Delta\varphi_3 r_3; \quad M_3 = P'_t r_3 = M_2 u_{21}$$

is the moment of wheel 3; $\Delta\varphi_3$ is the small angle of rotation of the wheel 3 at the fixed gear wheel 4.

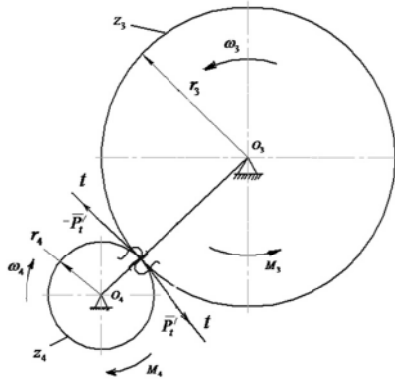

Fig. 3. Determination of rigidity of the reducer cog-wheels gearing III in the scheme of the drive drum of the mill regarding fig. 1

Thus,

$$P'_t = \frac{M_3}{r_3} \text{ and } M_3 = (cr_3^2)\Delta\varphi_3 = c_{34}\Delta\varphi_3, \quad (8)$$

where $c_{34} = cr_3^2$ is the angular rigidity of gearing of the wheels 3 and 4, given to the wheel 3 at the motionless wheel 4.

Similarly, with the wheel 3 fixed,

$$S'_t = \Delta\varphi_4 r_4.$$

If the moment 4 is put to the gear wheel

$$M_4 = P'_t r_4 = M_3 u_{43},$$

it will turn to the small corner $\Delta\varphi_4$.

Thus,

$$M_4 = (cr_4^2)\Delta\varphi_4 = c_{43}\Delta\varphi_4, \quad (9)$$

where $c_{43} = cr_4^2$ is the angular rigidity of gearing of the wheels 3 and 4, given to the gear wheel 4, at the fixed wheel 3.

The rigidity of shaft of the drive drums of mills are determined by the formula

$$c_d = \frac{\sigma J_p}{l}, \quad (10)$$

where $\sigma = 8 \cdot 10^4$ MPa is the elasticity module on shift of the shaft material (steel); $J_p \approx 0,1d^4$, polar moment of inertia of shaft section; d is the diameter of the shaft.

The step shaft rigidity can be defined in two ways:

- either by adding rigidities of separate sites of different diameters and length;
- or regarding equivalent diameter on the calculating length.

If the site of the shaft has veneer and spline connection, then rigidity is determined taking them into consideration.

Rigidity of the elastic couplings connecting the ends of shaft of the drive drums of mills generally is defined as the relation

$$c_M = \frac{\Delta M}{\Delta\varphi}, \quad (11)$$

where $\Delta M = M_2 - M_1$; $\Delta\varphi = \varphi_2 - \varphi_1$ – changes of the given moment and corners of the twisting of the shaft ends corresponding to them.

For operation of drives, damping abilities of couplings which are estimated by the size of energy absorbed by them at deformation of their elastic elements due to external or internal friction, are of special value.

Let, for example, overall dimensions of the coupling with plates be given and its rigidity C [7] be known. The most power-intensive coupling of V and number of plates of z (fig. 4, 5) is to be received.

The thinner plates are chosen, the more of them need to be taken to obtain the set rigidity. Therefore, the coupling with such minimum thickness of plates will be the most power-intensive at which in the coupling their greatest number z is located given that tension σ and τ do not surpass the admissible $\sigma \leq [\sigma]$; $\tau \leq [\tau]$.

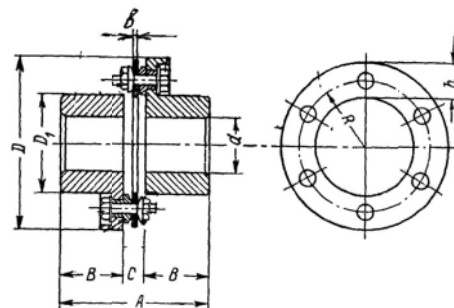

Fig. 4. The semi rigid coupling with steel disks

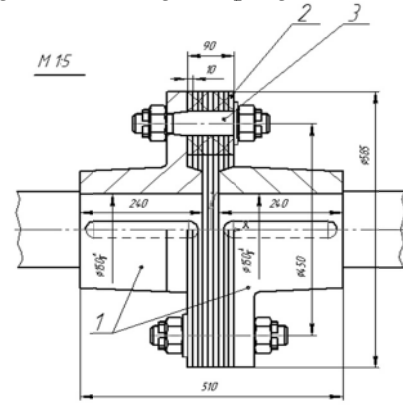

Fig. 5. Design and sizes of the coupling M2 of the mill drive: 1 – semi-couplings; 2 – disks; 3 – fingers

Let the torque at which tension in plates reaches permissible value be equal to M_{max} . Then the maximum energy accumulated by the linear coupling is equal to

$$A_{\sigma} = \frac{1}{2} M_{max} \varphi.$$

But since

$$\varphi = \frac{M_{max}}{C},$$

then

$$A_{\sigma} = \frac{1}{2} \frac{M_{max}^2}{C}.$$

On the other hand,

$$A_{\sigma} = k_{\sigma} \frac{[\sigma]^2}{2E} zV,$$

and, hence

$$\frac{1}{2} \frac{M_{max}^2}{C} = k_{\sigma} \frac{[\sigma]^2}{2E} zV.$$

Here we obtain

$$M_{max} = [\sigma] \sqrt{\frac{k_{\sigma} C}{E} zV}. \quad (12)$$

Namely, with the same $[\sigma]$, a bigger torque can be transferred provided comparatively bigger volume is occupied by elastic elements.

The given reasons explain aspiration to carry out couplings with the packages gathered from separate plates. Thus, it is necessary to consider that thanks to friction between steel plates the coupling gains capability of damping of fluctuations [8].

While comparing the couplings whose elastic elements are made from the same material, it is enough to compare only values of sizes of coefficients k_{σ}, k_{τ} . For steel, it is also possible when elements of one couplings work for bend, others – on torsion, as ratios [9] are carried out for steel

$$\frac{E}{G} \approx 2,6 \quad \text{and} \quad \frac{[\sigma]}{[\tau]} \approx 1,6.$$

Consequently,

$$\left(\frac{[\sigma]}{[\tau]} \right)^2 \approx 2,6$$

and it means that

$$\frac{[\sigma]^2}{2E} \approx \frac{[\tau]^2}{2G}.$$

Values of coefficients k_{σ} and k_{τ} can be calculated, using formulas of work of deformation of an elastic body

$$A_{\sigma} = \int_0^{P_{don}} P dy \quad \text{or} \quad A_{\tau} = \int_0^{M_{kp}} M_{kp} d\varphi. \quad (13)$$

The sizes and parameters of the couplings used in the drive of spherical mills are given in table.

Table

The sizes (in mm) and parameters of semi rigid disk couplings

d_{max}	n , об/мин	N , кВт	D	B	C	E	A	D_f
101.6	4 200	42.9	279.4	117.4	36.5	36.5	271.4	168.2
114.3	3 600	55.9	320.9	133.3	38.8	46.0	305.5	187.3
127.0	3 200	85.7	361.9	146.0	44.4	52.3	336.5	211.1
139.7	2 900	119.3	400.0	168.2	49.2	60.3	385.7	231.7
152.4	2 600	167.7	444.5	184.1	53.9	66.6	422.2	254.0
177.8	2 300	258.7	504.8	206.3	63.5	73.0	476.2	292.1
190.5	2 200	331.0	552.4	219.0	68.2	79.3	506.4	317.5

Rigidity of this coupling can be determined by the following approximate formula offered by N.Z. Suponitsky

$$C \approx \frac{Ezm^2bh}{6,5 \left(\frac{1}{R} + 0,01 \frac{1}{h} \right)}, \quad (14)$$

where b is thickness of disks; h, R – according to fig. 4; z is the number of disks; m is the number of deformable sections; E is the module of elasticity of the disk material in kg/cm^2 .

Skin, rubber, rubberized fabric, and others can also be applied as the material of an elastic disk by transferring of the small moments [10]. In this case the design of this coupling, to a certain extent, will be similar to a design of the coupling shown in fig. 5.

Conclusions.

1. The calculating scheme is developed to determine the rigidity of teeth gearings, shafts, and couplings connected in one kinematic chain of the spherical mill drive, made in the form of two-mass electromechanical system which unlike the known ones contains two concentrated inertial masses connected by one elastic viscous connection of the rotor of the engine and working body of the car.

2. On the basis of the calculating scheme of two-mass electromechanical system, the procedure of payments of its key parameters is defined: the moments of inertia, rigidity of transfers and others, allowing effectively carrying out design of electromechanical systems of spherical mills.

3. The analytical parameters defining rigidity of gear gearings, rigidity of the drive shaft and rigidity of the elas-

tic couplings connecting the ends of the drive shaft of the drums of spherical mills are found.

4. The offered technique allows defining the rigidity of elements of any electromechanical systems of drives entering the kinematic chain and to choose their design data in the future.

References / Список літератури

1. Lelikov, O.P. (2007), *Osnovy rascheta i proektirovaniya detaley i uzlov mashyn* [Bases of Calculating and Projecting Details and Machine Components of Cars], Mashynostroyeniye, Moscow, Russia.
2. Ivanov, M.N. and Finogenov, V.A. (2008), *Detali mashyn* [Details of Machines], Vysshaya Shkola, Moscow, Russia.
3. Wojnarowski, J. and Onishchenko, V. (2003), "Tooth wear effects on spur gear dynamics", *Mechanism and Machine Theory*, no. 38, pp. 161–178.
4. Belov, M.P. and Novikov, A.D. (2007), *Avtomatizirovannyi elektroprivod tipovykh proizvodstvennykh mekhanizmov i tekhnologicheskikh kompleksov* [The Automated Electric Drive of Standard Production Mechanisms and Technological Complexes], Akademiya, Moscow, Russia.
5. Belov, M.P., Zementov, O.I. and Kozyaruk, A.Ye. (2006), *Inzhenering elektroprivodov i sistem avtomatizatsyy* [Engineering of Electric Drives and Systems Automation], Akademiya, Moscow, Russia.
6. Braslavsky, I.Ya., Ishmatov, Z.Sh. and Polyakov, V.N. (2004), *Energoberegayushchiy asinkhronnyy elektroprivod* [Energy Saving Asynchronous Electric Drive], Akademiya, Moscow, Russia.
7. Nesmiyanov, I.A. and Khavronina, V.N. (2012), "The kinematic and kine statistic analysis of the elastic damping coupling", *Sovremennaya Tekhnika i Tekhnologii*, no. 7.
8. Khetagurov, V.N. and Gegelashvili, N.V. (2000), "Regarding the definition of the resource of working elements of centrifugal mills", *Collection of Scientific Works SKSTU*, no. 7, Vladikavkaz, Russia.
9. Ristivojevic, M., Lazovic, T. and Vencl, A. (2013), "Studying the load carrying capacity of spur gear tooth flanks", *Mechanism and Machine Theory*, no. 59, pp. 125–137.
10. Fernander del Rincon, A., Viadero, F., Iglesias, M., Garcia, P., de-Juan, A. and Sancibrian, R. (2013), "The model for studying the meshing stiffness in spur gear transmissions", *Mechanism and Machine Theory*, no. 61, pp. 30–58.

Мета. Визначення жорсткості зубчастих передач, валів, муфт, сполучених в один кінематичний ланцюг приводу кульового млина.

Методика. Важливим етапом складання розрахункової схеми електромеханічної системи є визначення її параметрів. Причому, якщо параметри електродвигунів можуть бути прийняті за каталогами, то моменти інерції, жорсткості передач і інші параметри підлягають розрахунку.

Результат. Знайдені аналітичні параметри, що визначають жорсткість зубчастих зачеплень, валів приводу та пружних муфт, які сполучають кінці валів приводу барабанів кульових млинів.

Наукова новизна. Для визначення жорсткості конструктивних елементів, що входять до розрахункової схеми електромеханічної системи приводу кульового млина, обрана розрахункова динамічна модель, виконана у вигляді двомасової електромеханічної системи, що містить дві зосереджені інерційні маси, сполучені одним пружним в'язком зв'язком ротора двигуна та робочого органу машини.

Практична значимість. Розглянуті зубчасті зачеплення кульового млина та діючі передавані ними сили, що деформують зубці та зв'язують їх пружні деформації. Запропонована методика дозволяє визначити жорсткість елементів, що входять до кінематичного ланцюга будь-яких електромеханічних систем приводів, і вибрати надалі їх конструктивні параметри.

Ключові слова: кульовий млин, зубчасті зачеплення, пружність, жорсткість, момент інерції, привід, муфта

Цель. Определение жесткости зубчатых передач, валов, муфт, соединенных в одну кинематическую цепь привода шаровой мельницы.

Методика. Важным этапом составления расчетной схемы электромеханической системы является определение ее параметров. Причем, если параметры электродвигателей могут быть приняты по каталогам, то моменты инерции, жесткости передач и другие параметры подлежат расчету.

Результат. Найдены аналитические параметры, определяющие жесткость зубчатых зацеплений, валов привода и упругих муфт, соединяющих концы валов привода барабанов шаровых мельниц.

Научная новизна. Для определения жесткости конструктивных элементов, входящих в расчетную схему электромеханической системы привода шаровой мельницы, выбрана расчетная динамическая модель, выполненная в виде двухмассовой электромеханической системы, содержащей две сосредоточенные инерционные массы, соединенные одной упругой вязкой связью ротора двигателя и рабочего органа машины.

Практическая значимость. Рассмотрены зубчатые зацепления шаровой мельницы и действующие передаваемые ими силы, деформирующие зубья и связывающие их упругие деформации. Предложенная методика позволяет определить жесткость элементов, входящих в кинематическую цепь любых электромеханических систем приводов, и выбрать в дальнейшем их конструктивные параметры.

Ключевые слова: шаровая мельница, зубчатые зацепления, упругость, жесткость, момент инерции, привод, муфта

Рекомендовано до публікації докт. техн. наук
О.М. Шаенком. Дата надходження рукопису 04.12.13.