

ТЕХНОЛОГІЇ ЕНЕРГОЗАБЕЗПЕЧЕННЯ

УДК 621.51, 621.365, 62-83-52

Ya. S. Paranchuk, Dr. Sci. (Tech.), Professor,
R. Ya. Paranchuk, Cand. Sci. (Tech.)

National University "Lviv Politechnics", Lviv, Ukraine, e-mail:
yparanchuk@yahoo.com

NEURAL NETWORK SYSTEM FOR CONTINUOUS VOLTAGE MONITORING IN ELECTRIC ARC FURNACE

Я. С. Паранчук, д-р техн. наук, проф.,
Р. Я. Паранчук, канд. техн. наук

Національний університет „Львівська політехніка“, м. Львів,
Україна, e-mail: yparanchuk@yahoo.com

НЕЙРОМЕРЕЖЕВА СИСТЕМА НЕПЕРЕРВНОГО КОНТРОЛЮ НАПРУГ ДУГ ДУГОВОЇ СТАЛЕПЛАВИЛЬНОЇ ПЕЧІ

Purpose. Development of mathematical model for operational calculation of instantaneous arc voltages values during melting aimed to determine the current values of the short circuit elements parameters in the arc steel melting furnace.

Methodology. The continuous voltage monitoring algorithm was based on the methods of neural network estimation of power circuit parameters, precise mathematical model of the power circuit, arc gaps and primary sensors of the controlled arc furnace coordinates in three-phase instantaneous coordinates, and the method of arc voltages calculation using numerical integration of nonlinear differential equations system with variable parameters.

Findings. The structure and algorithm of continuous monitoring of voltages have been developed based on principles of neural network parameter identification. The structural and parametric syntheses of neural networks have been performed. The numerical model of the arc voltages monitoring system have been created and the precision of the instantaneous voltage monitoring have been studied. The increase of the voltage measurements precision was proved.

Originality. The mathematical model of operational calculation of the instantaneous arc voltages values was developed. This model takes into account the current values of the arc furnace short circuit elements parameters, which are continuously identified by neural network during melting. It allows us to improve the accuracy of the continuous arc voltages monitoring.

Practical value. The developed structure of the continuous arc voltage monitoring system, which functions based on the principles of neural network assessment of the parameters of the power circuit elements, allows us to increase the accuracy of the arc voltages calculation, which gives the rationale for its implementation in electric arc furnaces. This will allow us to enhance the dynamic and static accuracy of electric mode coordinates stabilization at a given level and increase several indices of electrotechnological efficiency of melting of heat-resistant steels and precision alloys in such furnaces.

Keywords: *arc steelmaking furnace, neural network, arc voltage, numerical model*

Introduction. In electric arc furnaces (EAF) electric energy is converted into the process heat of the furnace feed melting in the arc gaps of the three-phase arc system. In each electric discharge, energy release is concentrated in small volumes, which allows obtaining high temperatures in the furnace melting space. Conditions and modes of arcing and parameters of EAF low-voltage circuit elements during melting are continuously changing. Arcs in the power circuit (PC) of the electric arc furnace are substantially non-linear elements, and their equivalent resistance varies over a wide range – from zero at operational short circuit to infinity at arc extinction.

Statement of the research problem Real-time estimation of the EAF low-voltage circuit (LVC) elements parameters and measurement of arc voltage for electric mode (EM) control signal generation, in particular those based on indices of energy and technological efficiency of melting, EM coordinates control, in particular arc power, automatic recognition of melting technological stages based on real-time estimation of information-bearing parameters of the melting process require accurate instantaneous values of electric parameters and coordinates of arc discharges, and first of all, arc voltage. The latter is prompted by the fact that control signals for electrode movement in typical differential electromechanical (electrohydraulic) power regulators, i. e. automatic control sys-

tems (ACS) of electrode position, are created as the functions of arc current and voltage.

The problem of accurate real-time estimation of arc voltage is especially acute for neural network systems of melting technological stages recognition, as well as for double-circuit systems of high-speed EM coordinates control. In double-circuit ACS structure, due to change of artificial external characteristics dependencies of the arc furnace, arc length control should be performed according to the law of voltage deviation from the setpoint (arc voltage setpoint of the electrode position control system). Therefore, accuracy of real-time arc voltage estimation has a determining effect on both the accuracy of the neural network system of melting stages recognition and on the indices of dynamics and statics of arc length control and, hence, of arc voltage control, current and power, reactive power of the arc furnace and other EM coordinates, as well as on the integral values of energy and technological efficiency indices of the melting process in the electric arc furnace.

Defining of the unresolved problem. Due to a number of design and technological factors, implementation of continuous direct measurement of arc voltage during melting in the electric arc furnace is impossible. Therefore, in off-the-shelf arc power regulators (ARDM-T, ARDH, etc.) arc voltage signal in each phase is assumed to be equal to voltage between the point of connection of the flexible bus duct to the output busbars of the furnace transformer and the arc furnace shell. These signals differ from the actual arc voltages by the value of voltage drop on elements of the low-voltage circuit of the corresponding phase of the arc furnace, i.e. on flexible and rigid bus ducts, electrode and contact coupling of the electrode with the rigid bus duct. This has a negative impact on dynamic and static accuracy of all arc furnace EM coordinates control. Therefore, complex improvement of quality indices of EM coordinates control and energy and technological efficiency of steel melting in EAF using double-circuit ACS is possible only subject to a substantial increase in accuracy of real-time arc voltage estimation and identification of EAF LVC elements parameters.

Analysis of the recent solutions. There is a solution known where in the arc voltage measurement circuit in-series-connected resistance z is included, voltage drop on which in certain modes compensates voltage on the aforementioned elements of the furnace low-voltage circuit [1]. In reality, however, during the process of melting due to a number of factors, parameters (inductance and resistance) of the aforementioned LVC elements are continuously changing over a wide range, while parameters of the resistance z in the arc voltage measurement circuit are invariable. Therefore, compensation is partial, and accuracy of arc voltage measurement is rather low. The authors in [2] proposed a method of the arc furnace LVC elements parameters calculation and real-time calculation of arc voltages. However, this deterministic model does not take into account the relationship between resistance of the low-voltage circuit and arc current harmonic distortion, furthermore, LVC element parameters within the calculation periods are assumed to be invariable. Disregard of these factors reduces accuracy of arc voltage measurement.

Research objective. Taking into consideration these factors, the task of developing solutions aimed at enhanced accuracy of LVC parameters identification and real-time estimation of EAF arc voltage prompted both by the subsystems of melting technological stages recognition and by the subsystems of EM coordinates control and steel-melting mode control in arc furnaces is important and topical.

Given the dynamic, stochastic, non-stationary and phase-asymmetrical character of arc discharge parameters variation and the consequent character of power supply circuit element parameters change in the three-phase arc system without a zero conductor (arc furnace LVC), and consequently accurate mathematical models of EAF power circuit and circuits for measuring arc voltage cannot be obtained, a viable approach to implementation of high-precision continuous real-time estimation of arc voltages and identification of EAF LVC elements parameters is the application of neural network identification principles.

Summary of the main information. The developed functional diagram of the block for identifying low-voltage circuit parameters and real-time estimation of EAF arc voltages without electrical connections inside the furnace based on an artificial neural network (NN) is shown in Fig. 1.

In each phase of the arc voltage measurement electric circuit, voltage on the primary winding of the voltage measuring transformers TV is the sum of drops of arc voltage (u_{aA}, u_{aB}, u_{aC}), low-voltage circuit active resistance (R_A, R_B, R_C) voltage drop, and voltage drop across internal (L_A, L_B, L_C) and mutual (L_{AB}, L_{BC}, L_{CA}) inductances of low-voltage circuit elements. So, for the arc voltage measurement circuit in phase A (primary winding circuit of the voltage measuring transformer TV_A), the voltage balance equation is as follows

$$u_{phA} = u_{aA} + R_A i_{aA} + L_A \frac{di_{aA}}{dt} + L_{AB} \frac{di_{aB}}{dt} + L_{CA} \frac{di_{aC}}{dt}, \quad (1)$$

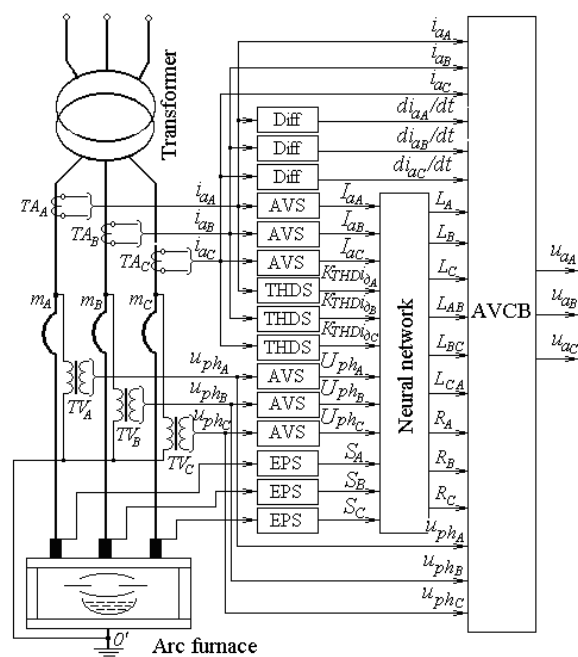

Fig. 1. Functional diagram of the block for real-time estimation of LVC parameters and EAF arc voltages

where u_{phA} is voltage between point m_A of the phase A power circuit and arc furnace zero point $0'$ (Fig. 1).

The functional diagram of the power supply system element connections in the EAF three-phase arc system is presented in Fig. 2. Dynamic asymmetry of EAF phase load stems from the random character of change of arc length and LVC elements resistance. However, on average, within certain time intervals due to appropriate adjustment of EM coordinates ACS, phase loads are almost equalized. However, in addition to the aforementioned dynamic asymmetry, there is also static asymmetry, which is caused by geometrical asymmetry of the electric arc furnace LVC structure.

Parameters that are changing the most are mutual inductances of flexible cables forming a loop, which compensate the movement of the rigid bus ducts in the process of arc length control and the furnace tilting. Considerable static variation of the rigid and flexible bus ducts mutual inductances and their random fluctuations due to changes in relative position of the rigid and flexible bus ducts in the phases lead to 'wild' and 'dead' phase effects, which has a negative impact on the technical and economic indices of EAF functioning, causes uneven heating of the furnace feed and the melt across the furnace, non-uniform wear of the furnace lining, leads to voltage asymmetry in power supply network, etc. Mutual inductances of the flexible and rigid bus ducts which move together with the electrode arms have the largest value, asymmetry and amplitude of variation. Therefore, for accurate compensation of the changes of inductance and resistance in the circuits of arc voltage control in each phase measurement channel, it is necessary to monitor their change and to adequately consider their obtained values in arc voltage calculation models.

The specificity of the proposed arc voltage control model and the circuit implementing it involves the necessity of continuous calculation of current values of resistances R_A, R_B, R_C and internal L_A, L_B, L_C and mutual L_{AB}, L_{BC}, L_{CA} inductances of the arc furnace LVC between the points $m-0'$ of the three-phase arc system power circuit, which has been implemented on the basis of NN.

Data which are continually input into the neural network include arc currents averaged over the period (RMS

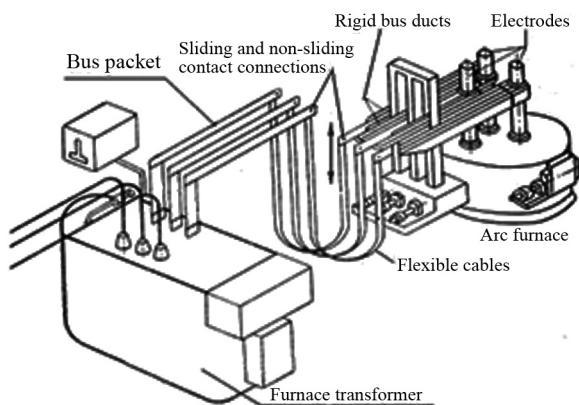

Fig. 2. Functional diagram of element connections in the three-phase arc power supply system

or running average absolute values) I_{aA}, I_{aB}, I_{aC} , voltages between the points $m-0$ $U_{phA}, U_{phB}, U_{phC}$ of the three-phase arc system power circuit, total harmonic distortion (THD) of arc current $K_{THDi_{aA}}, K_{THDi_{aB}}, K_{THDi_{aC}}$ and signals of the current position of each phase electrode S_A, S_B, S_C relatively to a certain reference (zero) point. The specified elements of the neural network input vector are obtained at the outputs of the averaged value sensors (AVS) of arc currents and phase voltages, arc current total harmonic distortion sensors (THDS) and electrode position sensors (EPS), respectively.

The output vector of calculated current values of the low-voltage circuit element parameters $\vec{V} = |L_A, L_B, L_C, L_{AB}, L_{BC}, L_{CA}, R_A, R_B, R_C|$ and the vector of instantaneous values of arc currents $\vec{i}_a = |i_{aA}, i_{aB}, i_{aC}|$ which is obtained at the arc current measuring transformers TA outputs, the arc current derivatives vector $\vec{di}_a/dt = |di_{aA}/dt, di_{aB}/dt, di_{aC}/dt|$ obtained at the outputs of the differentiators Diff (Rogowski coils) and the instantaneous phase voltage vector $\vec{u}_{ph} = |u_{phA}, u_{phB}, u_{phC}|$ are input into the arc voltage calculation block (AVCB), in which the output vector of arc voltages \vec{u}_a is calculated using the following expressions

$$\begin{aligned} u_{aA} &= u_{phA} - R_A i_{aA} - L_A \frac{di_{aA}}{dt} - L_{AB} \frac{di_{aB}}{dt} - L_{CA} \frac{di_{aC}}{dt}; \\ u_{aB} &= u_{phB} - R_B i_{aB} - L_B \frac{di_{aB}}{dt} - L_{AB} \frac{di_{aA}}{dt} - L_{BC} \frac{di_{aC}}{dt}; \\ u_{aC} &= u_{phC} - R_C i_{aC} - L_C \frac{di_{aC}}{dt} - L_{BC} \frac{di_{aB}}{dt} - L_{CA} \frac{di_{aA}}{dt}. \end{aligned} \quad (2)$$

Reference values of the element parameters $L_A^e, L_B^e, L_C^e, L_{AB}^e, L_{BC}^e, L_{CA}^e$ of the neural network output vector \vec{V}^e at every step of training are presented by solving a system of 6th order algebraic equations, which is comprised of voltage balance equations on LVC elements between the points $m-0'$ for six consecutive moments of current crossing zero in the process of melting (passive experiment). At these moments, arc voltage and LVC element resistance voltage in a certain phase are equal to zero. The vector of resistance reference values R_A^e, R_B^e, R_C^e is calculated based on the relationships obtained in specially set active experiments. In these experiments reference values of resistance can be calculated taking into account the existing surface effect and its increased manifestation at significant total harmonic distortion of arc current.

The performed analysis of functional properties of typical artificial neural networks showed that the most viable option for the discussed task of immediate identification of arc furnace LVC element parameters is the neural network with direct signal propagation and training algorithm based on error back propagation. One of the implementation variants of the proposed neural-network-based calculation of LVC parameters is the use of three neural networks of the above type, in each of them one of the following three groups of LVC parameters is calculated: resistance R_A, R_B, R_C , internal L_A, L_B, L_C and mutual L_{AB}, L_{BC}, L_{CA} inductances. This approach simplifies the structure and procedure for NN training to identify a certain parameter, whereas specialization of each neural network struc-

ture in identification of only one LVC parameter (i.e., its training on the standard implementations of only one LVC parameter variation) to a certain extent increases accuracy of calculation of each controlled parameters of the arc furnace LVC elements. One of the studied neural network structures for calculation of particularly dynamically varying parameters – mutual inductances of flexible and rigid bus ducts of the low-voltage circuit and EAF electrodes – is presented in Fig. 3.

Only those signals of the input neural identifier vector are input into each neural network whose variation most strongly correlates with the processes of change of a corresponding LVC parameter calculated at its output, i.e. signals of coordinates which considerably affect the fluctuation of its value.

The study of the efficiency and accuracy of neural-network identification of dynamically varying parameters of the EAF low-voltage circuit and of continuous calculation of arc voltage using their obtained values, as well as research of efficiency of the proposed procedure of the synaptic connections matrix synthesis (training procedure) and testing of each NN were accomplished using the created digital model of the EAF power circuit. The functional diagram of the developed EAF power circuit mathematical and digital model in instantaneous three-phase coordinates is shown in Fig. 4. The designed model adequately simulates EM coordinates variation at the level of instantaneous values, appropriately simulates real sto-

chastic characteristics of the disturbance variation based on arc length and characteristics of variation of resistances R_A, R_B, R_C , internal L_A, L_B, L_C and mutual inductances L_{AB}, L_{BC}, L_{CA} of the arc furnace LVC elements.

The digital model uses two random-process generators RPG1 and RPG2 which generate processes $S(t_i)$ of the electrode arms (rigid bus ducts) position change and $f_a(t_i)$ of arc length random fluctuations in the furnace melting area [3].

The non-linear function transformer implements a mathematical model of the relation between the relative position of the flexible cables and rigid bus ducts (which are attached to the electrode arms) and current values of mutual inductances L_{AB}, L_{BC}, L_{CA} between individual phases $\bar{L} = \Psi(\bar{S})$. Implementation of non-linearities of $L_j(I_a)$ (internal inductance, $j = A, B, C$), $R_j(I_a)$ (resistance), $u_a(i_a)$ (dynamic arc volt-ampere characteristics), as well as of the processes $S(t_i)$ and $f_a(t_i)$ as identified in the experimental study of the arc furnace DSP-3 modes enabled adequate simulation of the furnace arc voltage $u_a(t_i)$ and current $i_a(t_i)$ real variation processes at the level of instantaneous and RMS values.

As input, signals of arc currents $i_{aA}(t_i), i_{aB}(t_i), i_{aC}(t_i)$ and phase voltages $u_{phA}(t_i), u_{phB}(t_i), u_{phC}(t_i)$, at points m (Fig. 1), which are also input signals of the electrodes movement control signal generation block in the existing power regulators (e.g., ARDM-T), and output signals from the electrode arm position sensors $S_j(t_i)$ in relation to their certain reference position are fed into the arc voltage calculation block. Averaged value sensors AVS (of RMS or half-period average values) and arc current total harmonic distortion sensors THDS output signals $I_{aj}(t_i)U_{phj}(t_i)$ and $K_{THDj}(t_i)$, which along with signals $S_j(t_i)$ form the input vector of the general neural network. Differentiators Diff (Rogowski coils) output derivatives $di_{aA}/dt, di_{aB}/dt$ and di_{aC}/dt of instantaneous arc current values.

At the output of the neural network, processes of LVC element parameters variation – resistances $R_A(t_i), R_B(t_i), R_C(t_i)$, internal $L_A(t_i), L_B(t_i), L_C(t_i)$ and mutual $L_{AB}(t_i), L_{BC}(t_i), L_{CA}(t_i)$ inductances of the arc furnace electric power circuit (LVC) elements are calculated.

In the arc voltage calculation block, taking into account the obtained current values of the above-listed LVC element parameters $R_A(t_i), R_B(t_i), R_C(t_i), L_A(t_i), L_B(t_i), L_C(t_i), L_{AB}(t_i), L_{BC}(t_i), L_{CA}(t_i)$ and derivatives of instantaneous arc current values $di_{aA}/dt, di_{aB}/dt, di_{aC}/dt$, on the basis of the model (2), at each i -th step of time sampling instantaneous values of arc voltages $u_{aA}(t_i), u_{aB}(t_i), u_{aC}(t_i)$ are calculated.

The block diagram of the functioning EAF power circuit digital model algorithm and models of arc voltage $u_a(t_i)$ real-time computation is shown in Fig. 5. The main loop over the time $t \in [0, T_{max}]$ of the EAF power circuit EM coordinate variation simulation is implemented by Blocks 4–10. Numerical integration of the differential equation system is carried out in Block 5 and results in instantaneous values of arc currents $i_{aA}(t_i), i_{aB}(t_i), i_{aC}(t_i)$ and voltages $u_{aA}(t_i), u_{aB}(t_i), u_{aC}(t_i)$ at each i -th integration step. Block 6 calculates $f_a(t_i), S_j(t_i), u_{aj}(i_{aj}(t_i))$ and $L_{kj}(t_i)$. Block 7 implements calculations of half-period average arc voltages \bar{U}_{aj} and currents \bar{I}_{aj} , and arcs current

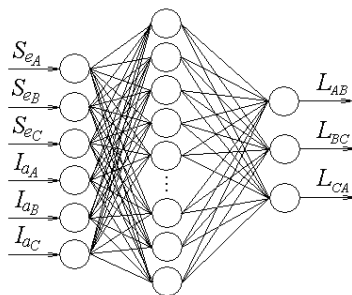

Fig. 3. NN for L_{AB}, L_{BC}, L_{CA} calculation

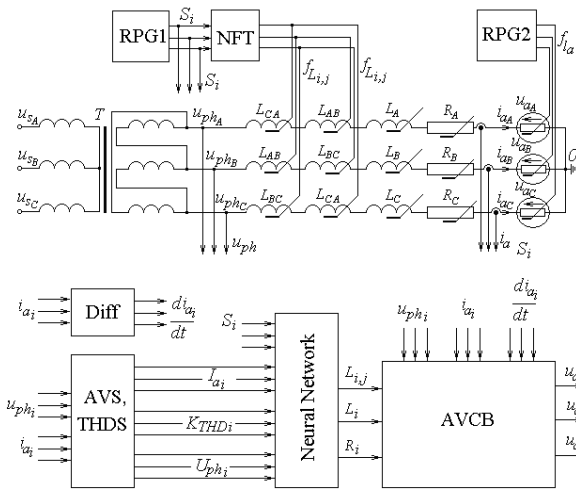

Fig. 4. Functional diagram of the electric arc furnace power circuit mathematical model

THD values \bar{K}_{THD} based on harmonic analysis of arc currents within the period. In Block 8, the designed neural networks implement the procedure of calculation of resistances $R_A(t_i), R_B(t_i), R_C(t_i)$, internal $L_A(t_i), L_B(t_i), L_C(t_i)$ and mutual $L_{AB}(t_i), L_{BC}(t_i), L_{CA}(t_i)$ inductances of the arc furnace LVC elements.

In Block 9 instantaneous arc voltage values $u_{aA}(t_i), u_{aB}(t_i), u_{aC}(t_i)$ are calculated based on the model (2), i. e. the AVCB algorithm is implemented (Fig. 1). Current reference and obtained parameters $R_j(t_i), L_j(t_i), L_{AB}(t_i), L_{BC}(t_i), L_{CA}(t_i)$ of the EAF low-voltage circuit are recorded in Block 10 of the time-based loop. Blocks 11 and 12 build time dependencies of the obtained and reference processes of the LVC element parameter variation and calculate error of their calculation for the studied structures, parameters and characteristics of the neural network.

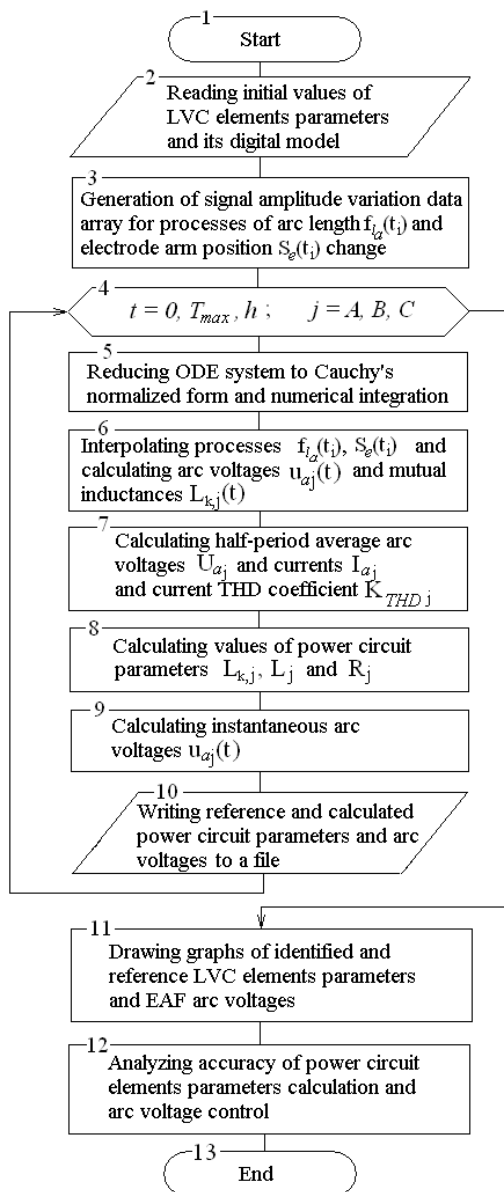

Fig. 5. Block diagram of the EAF power circuit digital model algorithm and arc voltage calculation

In order to achieve the desired accuracy of the arc furnace LVC element parameter identification and, hence, the operational control of arc voltage, accuracy of parameter identification was studied using various types of neuron's activation functions, numbers of neurons in the hidden layer, methods of the neural network training, etc.

The best results of mutual inductance calculation (i. e., the smallest absolute and relative errors) were obtained for NN with one hidden layer containing 35 neurons with 'tansig' activation function and while training NN using the error back propagation method.

Fig. 6, a shows input signals of the neural network, i. e. arc currents $I_{aA}(t_i), I_{aB}(t_i), I_{aC}(t_i)$ plotted against time; Fig. 6, b presents positions $S_A(t_i), S_B(t_i), S_C(t_i)$ of the rigid bus ducts connected to the electrode arms, respectively.

Fig. 7 shows reference and obtained processes of arc furnace LVC mutual inductance variations $L_{AB}(t_i), L_{BC}(t_i), L_{CA}(t_i)$, which are identified by the designed neural network (Fig. 3) having the structure and parameters discussed above.

Analysis of neural network calculation processes of mutual inductances presented in Fig.7 showed that average relative error of $L_{AB}(t_i)$ and identification within the time interval $t = 28$ s is $\bar{\delta} = 1.7 \cdot 10^{-7}$, and for $L_{CA}(t_i)$ it is $\bar{\delta} = 1.7 \cdot 10^{-7}$. The largest relative error of identification was at the moment of time $t \approx 18.5$ s while identifying the variation process for $L_{CA}(t_i)$ and was estimated at $\delta = 0.6 \cdot 10^{-2}$ in relation to the reference value. Mean relative error of resistances identification $R_A(t_i), R_B(t_i), R_C(t_i)$ amounted to $\bar{\delta} = 1.2 \cdot 10^{-5}$. The same level mean relative errors were also obtained for identification of other parameters of the arc furnace LVC elements and for real-time computation of arc voltage.

Since in the arc power regulators ARDM-T, ARDG, of SPU and STU series control signal for moving electrodes is generated on the $U_{aj}(t_i)$ signal basis, the increase in the accuracy of arc voltage operational control allows improved dynamic accuracy of stabilization (reducing dispersion) of EM coordinates, and consequently comprehensive improvement of energy efficiency indices, energy

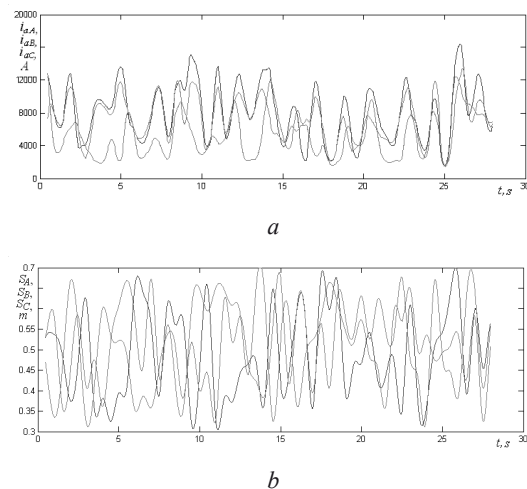

Fig. 6. NN input signals: arc currents $I_{aA}(t_i), I_{aB}(t_i), I_{aC}(t_i)$ (a) and bus ducts positions $S_A(t_i), S_B(t_i), S_C(t_i)$ (b) vs. time

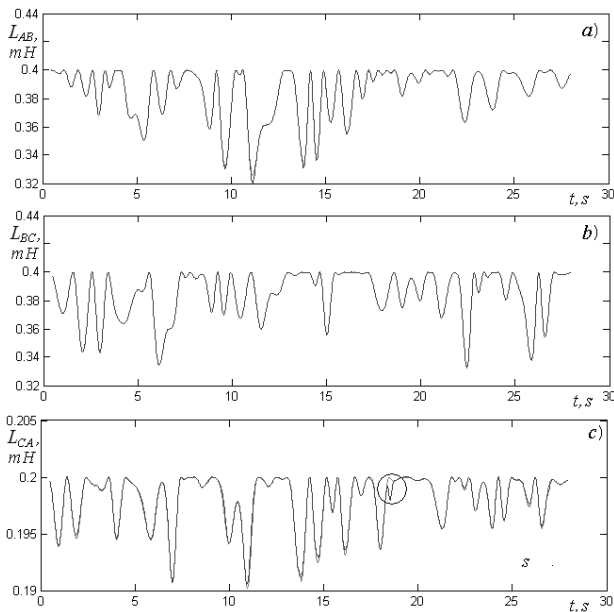

Fig. 7. Reference and obtained processes of EAF LVC elements mutual inductances variation $L_{AB}(t_i)$, $L_{BC}(t_i)$, $L_{CA}(t_i)$ plotted vs. time

saving and electromagnetic compatibility, in particular reduced specific energy consumption and improved performance of the arc furnace [4].

Further research will be focused on development of design solutions for practical implementation of the neural network model of LVC elements parameters calculation and algorithm of arc voltage continuous control on the basis of DSP-3 arc furnace, as well as experimental research of accuracy of parameter identification, arc voltage control and indices of energy and technological efficiency of arc furnace utilization.

Conclusions. 1. Use of neural network identification models makes it possible to continuously obtain high-accuracy data (mean relative error being $\bar{\delta} < 10^{-5}$) on variation of parameters of the LVC elements of the arc furnace during melting.

2. In comparison to the conventional solutions, practical implementation of the developed mathematical model and block diagram of the algorithm for continuous calculation of arc voltage of the arc furnace, which take into account the variation of the LVC elements parameters, will result in increased accuracy of continuous arc voltage control during the melting process in electric arc furnaces.

3. Since phase control signals for moving electrodes are formed on the arc voltage signal basis, this will make it possible to raise the dynamic and static accuracy of EM coordinate control, and, as a consequence, to improve a number of energy and technological efficiency indices and electromagnetic compatibility of the arc furnace modes and power supply network.

References / Список літератури

1. Mineyev, A. R., Korobov, A. I. and Pogrebinskiy, M. Ya. 2004. *Modelirovaniye elektrotekhnologicheskikh protsessov i ustanovok* [Modelling of electrotechnical processes and installations]. Moscow: Sputnik+.

Минеев А. Р. Моделирование электротехнологических процессов и установок / Минеев А. Р., Коробов А. И., Погребиский М. Я – М.: Компания Спутник+, 2004. – 124 с.

2. Denis, B. D. and Marushchak, Ya. Yu., 1984. *Equipment for determination of the electrical characteristics of the current-conducting wire and arcing voltage of the three-phase electric arc furnace*. А.С. No.1086557 SSSR, МКИ H05B 7/148.

А.С. №1086557 СССР, МКИ H05B 7/148. Устройство для определения электрических параметров токопровода и напряжения дуг трехфазной дуговой печи / Б. Д. Денис, Я. Ю. Марущак. – Опубл. 15.04.84, Бюл. № 14.

3. Lozynsky, O. Yu., Paranchuk, Ya. S., Lozynsky, A. O. and Marushchak, Ya. Yu., 2004. Mathematical model of the system of melting and regulation of the modes of the DSP-EPM electrotechnical complex. *Naukovyi Visnyk Natsionalnoho Hirnychoho Universytetu*, 3, pp. 8–15.

Математична модель системи плавлення та регулювання режимів електротехнологічного комплексу ДСП-ЕПМ / О. Ю. Лозинський, Я. С. Паранчук [та ін.] // Науковий вісник гірничого університету, „Енергетика та автоматика“. – 2004. – № 3. – С. 8–15.

4. Mineyev, A. P., 1998. Energy saving statistical and dynamic optimization of the parameters and structures of computer assisted electric drives (on the example of an electric furnace). *Elektrotehnika*, 10, pp. 15–22.

Минеев А. Р. Энергосберегающая статистическая и динамическая оптимизация параметров и структур компьютеризированных электроприводов (на примере электрических печей) / А. Р. Минеев // Электротехника. – 1998. – № 10. – С. 15–22.

Мета. Розроблення математичної моделі для оперативного по ходу плавки розрахунку миттєвих значень напруг дуг та системотехнічних рішень для оцінки поточних значень параметрів елементів короткої мережі дугової сталеплавильної печі.

Методика. В основу алгоритму неперервного контролю напруг дуг покладено методику нейромережевої оцінки параметрів елементів короткої мережі, точні математичні моделі силового кола, дугових проміжків та первинних давачів контрольованих координат дугової печі в миттєвих трифазних координатах, метод розрахунку напруг дуг на основі числового інтегрування системи нелінійних диференціальних рівнянь зі змінними параметрами.

Результати. Розроблені структура та алгоритм системи неперервного контролю напруг дуг на основі принципів нейромережевої оцінки параметрів, виконані структурний і параметричний синтез нейронних мереж; складена цифрова модель розробленої системи контролю напруг дуг та виконані на ній дослідження точності неперервного контролю напруг дуг; підтверджений ефект підвищення точності вимірювання напруг дуг дугової печі.

Наукова новизна. Розроблена математична модель оперативного розрахунку миттєвих значень напруг дуг з урахуванням поточних значень параметрів елементів короткої мережі дугової печі, які неперервно впродовж плавки оцінюються нейронною мережею, що дало змо-

гу підвищити точність неперервного контролю напруг дуг.

Практична значимість. Розроблена структура системи неперервного контролю напруг дуг дугової сталеплавильної печі, яка функціонує на основі принципів нейромережевої оцінки параметрів елементів силового кола, дає змогу підвищити точність неперервного контролю напруг дуг, що підтверджує доцільність практичного її використання на дугових печах. Останнє дасть змогу покращити динамічну й статичну точність стабілізації координат електричного режиму на заданому рівні та, відповідно, підвищить низку показників електротехнологічної ефективності плавлення високолегованих сталей і прецизійних сплавів в цих печах.

Ключові слова: *дугова сталеплавильна піч, нейронна мережа, напруга дуги, цифрова модель*

Цель. Разработка математической модели для оперативного по ходу плавки расчета мгновенных значений напряжений дуг и системотехнических решений для оценки текущих значений параметров элементов короткой сети дуговой сталеплавильной печи.

Методика. В основу алгоритма непрерывного контроля напряжений дуг положена методика нейросетевой оценки параметров элементов короткой сети, точные математические модели силовой цепи, дуговых промежутков и первичных датчиков контролируемых координат дуговой печи в мгновенных трехфазных координатах, метод расчета напряжений дуг на основе численного интегрирования системы нелинейных дифференциальных уравнений с переменными параметрами.

Результаты. Разработаны структура и алгоритм системы непрерывного контроля напряжений дуг на

основе принципов нейросетевой оценки параметров, выполнены структурный и параметрический синтез нейронных сетей; составлена цифровая модель разработанной системы контроля напряжений дуг и выполнены на ней исследования точности непрерывного контроля напряжений дуг, подтвержден эффект повышения точности измерения напряжений дуг дуговой печи.

Научная новизна. Разработана математическая модель оперативного расчета мгновенных значений напряжений дуг с учетом текущих значений параметров элементов короткой сети дуговой печи, которые непрерывно на протяжении плавки оцениваются нейронной сетью, что позволило повысить точность непрерывного контроля напряжений дуг дуговой печи.

Практическая значимость. Разработанная структура системы непрерывного контроля напряжений дуг дуговой сталеплавильной печи, функционирующая на основе принципов нейросетевой оценки параметров элементов силовой цепи, позволяет повысить точность непрерывного контроля напряжений дуг, что подтверждает целесообразность ее практического использования в дуговых печах. Последнее дает возможность улучшить динамическую и статическую точность стабилизации координат электрического режима на заданном уровне и, соответственно, повысить ряд показателей электротехнологической эффективности плавления высоколегированных сталей и прецизионных сплавов в этих печах.

Ключевые слова: *дуговая сталеплавильная печь, нейронная сеть, напряжение дуги, цифровая модель*

Рекомендовано до публікації докт. техн. наук О.Ю.Лозинським. Дата надходження рукопису 17.01.15.