

UDC 681.2:532.64

DOI: 10.29202/nvngu/2018-1/16

R. M. Kondrat<sup>1</sup>, Dr. Sc. (Tech.), Prof.,  
 orcid.org/0000-0002-9653-2567,  
 A. V. Uhrynovskiy<sup>1</sup>, Cand. Sc. (Tech.),  
 orcid.org/0000-0002-3886-9639,  
 O. S. Sendeha<sup>2</sup>,  
 V. Ye. Blizniakov<sup>2</sup>,  
 T. V. Potiatynnyk<sup>2</sup>,  
 orcid.org/0000-0002-5515-2154

1 – Ivano-Frankivsk National Technical University of Oil and Gas, Ivano-Frankivsk, Ukraine, e-mail: rengr@nung.edu.ua; Andrewu@i.au

2 – Gas Production Department “Lvivhazvydobuvannya”, Lviv, Ukraine, e-mail: taras.potiatynnyk@ugv.ua

## PILOT TESTING TECHNOLOGY TO CLEAN GAS PIPELINES IN KHIDNOVYTSKE GAS FIELD

Р. М. Кондрат<sup>1</sup>, д-р техн. наук, проф.,  
 orcid.org/0000-0002-9653-2567,  
 А. В. Угриновський<sup>1</sup>, канд. техн. наук,  
 orcid.org/0000-0002-3886-9639,  
 О. С. Сендега<sup>2</sup>,  
 В. Є. Блізняков<sup>2</sup>,  
 Т. В. Потятинник<sup>2</sup>,  
 orcid.org/0000-0002-5515-2154

1 – Івано-Франківський національний технічний університет нафти і газу, м. Івано-Франківськ, Україна, e-mail: rengr@nung.edu.ua; Andrewu@i.au

2 – Газпромислове управління „Львівгазвидобування“, м. Львів, Україна, e-mail: taras.potiatynnyk@ugv.ua

## ДОСЛІДНО-ПРОМИСЛОВІ ВИПРОБУВАННЯ ТЕХНОЛОГІЇ ОЧИЩЕННЯ ВНУТРІШНЬОЇ ПОРОЖНИНИ ШЛЕЙФІВ СВЕРДЛОВИН ХІДНОВИЦЬКОГО ГАЗОВОГО РОДОВИЩА

**Purpose.** Improvement of hydraulic efficiency of the pipelines of the gas and gas-condensate wells by means of their internal cavity cleaning from fluid accumulations.

**Methodology.** The set tasks were solved by means of carrying out the experimental studies and determining the time, required for dissolution of the viscoelastic pig in water and condensate water with different content of the surface active agent. In order to determine the efficiency of using the viscoelastic pig, the appropriate pilot tests were performed on the pipelines of the Khidnovytske gas field wells.

**Findings.** The theoretical and actual values of the hydraulic resistance coefficient of the well flow lines were calculated for the conditions of the Khidnovytske gas field. The pipelines of the wells, where additional pressure losses occur due to the fluid accumulation in their lowered sections, were determined. In order to prevent formation of the water slugs in the pipelines of the wells, the technology of using the viscoelastic pig, which is water-soluble and consists of the domestic chemical agents, was proposed. The total gas flow rate increased by 1.1 thousand m<sup>3</sup>/day after the usage of the suggested technology.

**Originality.** A technology for cleaning the flow lines of the wells from the fluid accumulations with the help of the viscoelastic pig was developed on the basis of the water solution of the carboxymethyl cellulose and surface active agent with the possibility to regulate the destruction time of the polymer system.

**Practical value.** The proposed technology can be used for cleaning the internal cavity of the pipelines of the low-pressure gas and gas-condensate wells, as well as of the field gas pipelines, from the fluid accumulations. As a result, stable fault-free operation of the well with the increased flow rates of the gas and gas condensate is ensured.

**Keywords:** *technology, cleaning device, viscoelastic pig, surface active agent, gas pipeline*

**Introduction.** The problem of the fluid accumulation in the pipelines of the wells is quite topical for the conditions of the Khidnovytske gas field (GF). The Khidnovytske GF is at the final stage of development and it entered the gas lift operation period, which is characterized by low working pressures, high water-gas factors, and insignificant reserve concerning the working pressure decrease at the wellheads.

The solid and fluid particles precipitate due to the complex route profiles and low gas velocities in the lowered sections of the gas pipeline and in other places, where there are appropriate conditions, which results in the decrease in the “wetted” cross-section of the gas pipeline, reduction in its transmission capacity, and increase in the pressure losses during the gas flow movement. Therefore, the working pressure at the wellheads increases and the gas flow rates of the wells decrease.

In order to evaluate the operation efficiency of the system for gathering of the well production of the Khidnovytske GF, the calculations of the actual and theo-

retical values of the hydraulic resistance coefficients were carried out. Only the wells which have an individual pipeline were selected for these calculations. Table 1 shows the results of the calculations of the actual and theoretical values of the hydraulic resistance coefficients of the flow lines of the wells.

The results of the calculations are indicative of the excess of the actual pressure losses over the calculated ones in most wells. The actual hydraulic resistance coefficient is tenfolds-hundredfolds higher than the theoretical value of the coefficient. Therefore, it is necessary to introduce the measures in these wells that will improve the hydraulic efficiency of their flow lines.

**Analysis of the recent reseach and publications.** At present, cleaning of the internal cavity of the gas pipelines can be carried out with the help of the following means depending on some technological conditions:

- usage of the devices for fluid removal;
- introduction of the foaming surface active agents (SAA) into the gas pipeline;

- creation of high velocities of the gas flow movement;
- usage of different cleaning pigs.

Fig. 1 shows principle diagrams of the stationary devices for fluid removal [1] from the cavity of the active gas pipelines.

A condensate gathering tank (Fig. 1, *a*), depending on its type and design, usually consists of the tank for fluid collection 2, which is located under the gas pipeline 1, and blow-down line 3, which is connected with it with the help of the nipples 3. One end of the blow-down pipe is connected with the tank for fluid collection and the other one is connected with the shut-off valves on the surface.

The degree of entrapping of the associated formation water in the expansion chamber (Fig. 1, *b*) reaches 90 % due to the sharp decrease in the velocity of the gas flow due to the tie-in of the large-diameter pipe into the active gas pipeline while it does not exceed 80 % in the condensate gathering tanks. At such design of the expansion chamber, the fluid precipitates in the lower section of the

Table 1

Results of the calculations of the theoretical and actual values of the hydraulic resistance coefficients of the pipelines of the Khidnovytske GF wells

№	Well number	Pipe hydraulic resistance coefficient		Note
		theoretical, $\lambda_t$	actual, $\lambda_a$	
	2	3	4	5
1	22	0.019	0.019	
2	143	0.018	0.019	
3	112	0.020	0.840	additional pressure losses
4	114	0.018	0.018	
5	144	0.020	0.020	
6	116	0.026	2.010	additional pressure losses
7	117	0.026	0.540	additional pressure losses
8	115	0.020	0.045	additional pressure losses
9	146	0.020	0.020	
10	125	0.040	57.190	additional pressure losses
11	101	0.032	8.360	additional pressure losses
12	36	0.026	1.740	additional pressure losses
13	120	0.019	0.025	additional pressure losses
14	124	0.034	7.240	additional pressure losses
15	119	0.030	4.20	additional pressure losses
16	110	0.033	1.880	additional pressure losses
17	122	0.033	2.710	additional pressure losses
18	103	0.028	1.960	additional pressure losses
19	102	0.037	16.030	additional pressure losses
20	121	0.037	10.850	additional pressure losses
21	133	0.020	0.150	additional pressure losses
22	118	0.020	0.10	additional pressure losses
23	138	0.030	4.230	additional pressure losses
24	129	0.027	2.160	additional pressure losses
25	135	0.034	4.860	additional pressure losses
26	109	0.018	0.018	
27	134	0.02	0.021	
28	126	0.018	0.019	
29	201	0.024	0.340	additional pressure losses
30	131	0.033	6.710	additional pressure losses

large-diameter pipeline and it is periodically removed into the tank for fluid collection with the help of the nipples.

A drip (Fig. 1, c) is a pipe, which is tied into the gas pipeline. The tie-in place of the drip is the lowest point of the lowered section of the gas pipeline.

The stationary devices for fluid removal from the gas pipeline have their advantages and disadvantages. The simple design and relatively small investments can be considered to be among the advantages. These devices are installed on the gas pipelines in the places, where condensate and associated formation water can precipitate and accumulate with the highest probability. The fact that the fluid separation from the gas-liquid flow does not take place along the whole length of the gas pipeline [2] can be considered as one of their disadvantages.

Another way for solving this problem is the injection of the foaming solutions of the surface active agents (SAA). The foaming agents decrease the gas-liquid interfacial tension and thus promote foam generation. The generated foam is removed by the gas flow better because the foam density is much lower than the fluid density. Therefore, the SAA application creates conditions for fluid foaming and its removal using the natural gas energy. Work [3] shows the possibility for using the technology of foam cleaning and inhibition against corrosion of the internal surfaces of the gas field equipment. In order to realize the technology, the authors also propose a developed design of the foam generator. One of the disadvantages of this method is the fact that the generated foam gets into the inlet of the field gas treatment unit, does not fully separate on the first separation stage, and then it can go into the compressors and trunk gas pipeline, which later

results in destruction of the compressor blades and deterioration of the treated gas quality.

One of the ways for cleaning the internal cavity of the gas pipelines from the fluid accumulations is the creation of the pulse mode of the working gas flow movement by means of shutting off the linear valve of the active gas pipeline [4]. When the valve is shut off, the pressure on the gas pipeline section before the valve increases. After the needed pressure differential before and after the valve has been achieved, the valve is quickly released. The fluid is removed from the gas pipeline section before the valve due to the sharp increase in the gas flow velocity. Another way for realization of the pulse mode of the working gas flow in the gas pipeline is the temporary shutdown of all or some gas production wells with their further simultaneous putting into operation. Work [5] shows the results of the studies on the classification of the reasons of the gas pipeline cavity contamination, as well as the developed method for cleaning the cavity of the gas pipelines with the help of the high-velocity gas flow. The method provides for the calculation of the critical gas movement velocity, which should be achieved on the gas pipeline section by means of shutting off the shutting-off device on the block valve station and creation of the pressure differential. However, realization of this method on the in-field gas pipelines can lead to the violation of the established technological operation mode of wells and field gas treatment units, which limits the possibilities of its efficient application.

It is practically impossible to ensure high gas movement velocities (8–10 m/s), at which the fluid accumulation does not occur in the lowered sections of the pipelines of the wells [6], for the conditions of the flooded low-pressure gas and gas-condensate wells.

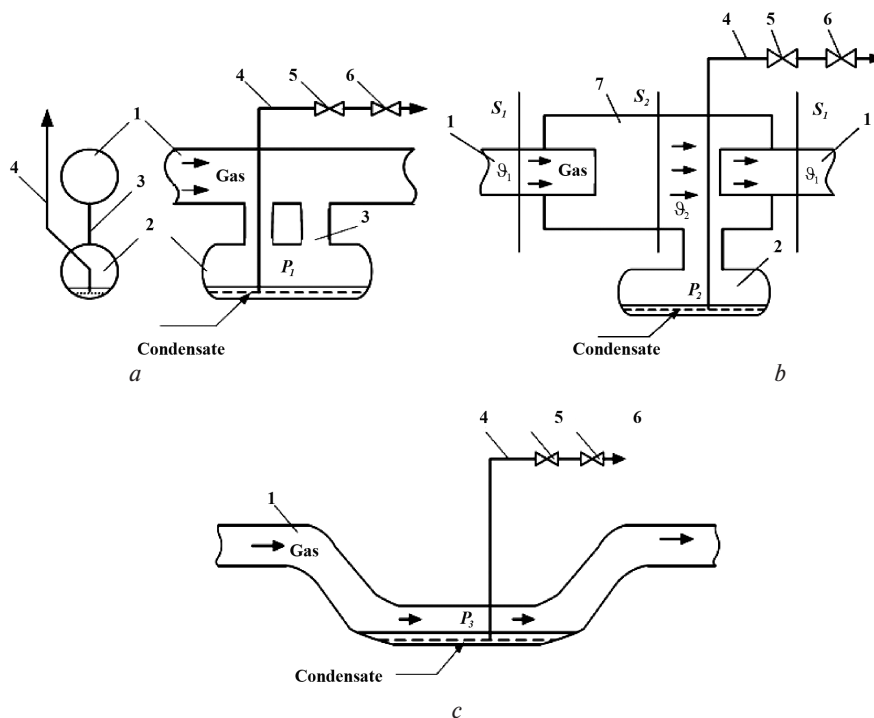

Fig. 1. Principle diagrams of devices for fluid removal from pipelines:

a – condensate gathering tank; b – expansion chamber; c – drip; 1 – gas pipeline; 2 – tank for fluid collection; 3 – nipples; 4 – blow-down line; 5, 6 – valves; 7 – expansion chamber

Still another way for cleaning the internal cavity of the gas pipelines is the usage of different cleaning devices. The cleaning devices are used periodically without or with the gas transportation interruption. Works [7, 8] provide the detailed analysis of different designs of the mechanical cleaning devices and their characteristic features. Work [8] presents the information about the new developed content of the self-destructive viscoelastic cleaning pig and appropriate laboratory studies for determining the time, required for its dissolution in water and condensate water, at different content of the surface active agent.

The devices (pigs) for cleaning the internal cavity of the gas pipelines can be classified in accordance with the manufacturing method and the diagram, shown in Fig. 2, on the basis of the studied domestic and foreign publications [3–5, 7, 8].

The application of the mechanical devices becomes more complicated due to the necessity of installation of the stations for their launching and receiving, as well as because of the necessity of maintenance of the appropriate pressure differential on the cleaning device in order to ensure the specific velocity of its movement in the gas pipeline cavity and control of the cleaning device passage along the gas pipeline.

The substantial weakness of the mechanical and rubber pigs is their wear and high probability of their sticking in the gas pipeline cavity.

**Unsolved aspects of the problem.** At present, the problems of application of the gels, which are used for cleaning the internal cavity of the pipelines, and possible ways of their introduction into the pipelines, remain not sufficiently covered in the literature.

**Objectives of the article.** Taking into account the results of the conducted analysis of the latest studies on the problem at issue, the application of a group of chem-

ical pigs requires more detailed examination in terms of the conditions of destruction of the gel system (hence, the necessity in equipment of the pipelines with the pig receiving chambers is redundant), reduction in adhesion of the gel to metal, and studying of the possible ways for introduction of the gel pigs into the pipeline.

**Presentation of the main research.** The scientists in Ivano-Frankivsk National Technical University of Oil and Gas (IFNTUOG) proposed the composition of the viscoelastic pig for cleaning the internal cavity of the field gas pipelines from the fluid that consists of the domestic chemical agents with the regulated period of dissolution of the pig material in water and condensate water.

The viscoelastic pig is prepared directly in the field by mixing the water, SAA, and carboxymethyl cellulose (CMC) until a uniform mixture is formed. The pig is then treated with methanol in order to reduce adhesion of the gel to metal. The methanol treatment of the pig can be carried out in static state by submerging the pig under the methanol level in a separate tank and in dynamic state by means of injection of some volume of methanol, then some volume of gel, and then again some volume of methanol into the pipeline.

The main properties of the viscoelastic cleaning pig are the following:

- does not collapse when being passed through the pipelines with different cross sections;
- does not collapse when the pipeline stops operating;
- has low adhesion to metal;
- dissolves in water during the set period of time after the process of the pipeline cleaning finished.

The appropriate laboratory studies were carried out in order to chose the pig composition and determine the duration of its dissolution in water, condensate, and system “water-condensate”. Based on the results of the laboratory

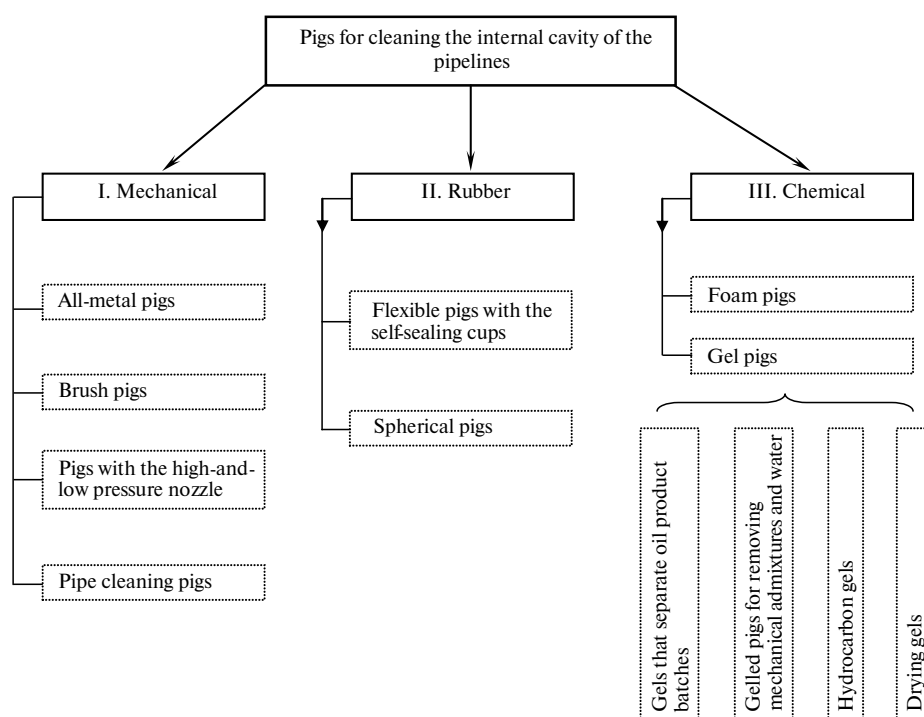

Fig. 2. Classification of pigs in accordance with the manufacturing method

experiments, it was found that it is possible to regulate the lifetime of the viscoelastic cleaning pig from approximately 40 minutes to more than one hour in water and from two hours and up to almost three hours in condensate water when the content of some of its components is modified.

There are two variants of cleaning the pipelines of the wells from the fluid accumulations: by means of launching the viscoelastic pig from the wellhead to the gas treatment unit (GTU) and in the backward direction.

The technology for cleaning the internal cavity of the field gas pipelines from the fluid and solid phase accumulations with the help of the viscoelastic pig includes the following stages:

- a) preparation of the gel of a certain composition depending on the conditions of use (gas pipeline length, pig movement velocity, and fluid composition to be removed);
- b) well shutdown, closure of the flowline valve of the well-control equipment, master valve closure, and gas bleed from the space between them;
- c) introduction of the gel pig into the gas pipeline.

There are two possible variants of the gel pig introduction into the gas pipeline:

1) via special launching chambers or flanged connections of the well-control equipment, which are demounted beforehand. The methanol treatment of the pig in this case is conducted in the separate tank by its submerging under the methanol level during 20–30 min;

2) via the buffer flange of the well-control equipment with the help of the pumping unit. According to this diagram of the methanol treatment of the pig, the methanol is divided into two equal portions; the first portion is injected before the gel introduction and the second portion is pumped in after the gel injection. In order to treat the pig with the methanol, the injected components are kept in this state for 20–30 min;

d) forcing through of the gel pig by the gas flow. There are also two variants of forcing through of the gel pig by the gas flow:

- 1) cleaning of the field gas pipeline is carried out onto the open pipe end (onto the flare line);
- 2) cleaning of the field gas pipeline is carried out directly onto the TU without any gas bleed into the atmosphere.

The pilot tests of the gel viscoelastic pig were performed on the pipelines of the wells of the Khidnovytske GF.

Taking into account the availability of the well-defined lowered sections (natural fluid traps) and considerable volume of the accumulated fluid contamination, the test fields of two pipelines of wells 118 and 116 were selected for the pilot tests. The pipeline of well 116 is characterized by the least length of 605 m and its flow rate is only 1.5 thousand m<sup>3</sup>/day. Therefore, the decision to clean the pipeline with the gas bleed into the atmosphere was taken in order to realize the technology for the first time.

The average gas flow velocity in the pipeline of well 116 is 1.4 m/s and the average gas flow velocity in the pipeline of well 118 is 5/5 m/s. Taking into account the fact that there are 5–6 for 90° bends and water slugs on the way of the pig movement, the maximum time of the pig passage to the pipeline end will not exceed 10–12 min.

The gel pig was prepared in accordance with the patent No. 78315 in the following way:

a) 1.5 kg of CMC, 10.74 kg of water, and 0.25 kg of SAA (Stinol) were put into the tank with the volume of 20 l and then they were mixed until a homogeneous gel formed;

b) the obtained mixture was submerged into the preliminarily prepared tank with methanol and kept there for 30 min;

c) then the cylindrical pig, whose diameter was a little bit bigger than the pipeline internal diameter, was formed from the obtained mixture.

Organization and sequence of the operations on cleaning the pipeline of well 116 from the fluid accumulations with the help of the viscoelastic pig were carried out in the following way:

a) the well was shut down, the flowline valve of the well-control equipment and the master valve were closed, and the gas was bled from the space between them;

b) the well buffer was equipped with the blow-down elbow;

c) the flowline end valves were closed before and after the measuring diaphragm and the gas was bled from the space between them;

d) the measuring diaphragm was removed and the prepared pig was inserted into the space, wherefrom the gas had been bled;

e) the measuring diaphragm was mounted and valves 7, 8, 5, and 1 were opened one-by-one (Fig. 3);

f) the gas was supplied from the preliminary gas treatment unit (PGTU) in the backward direction in order to

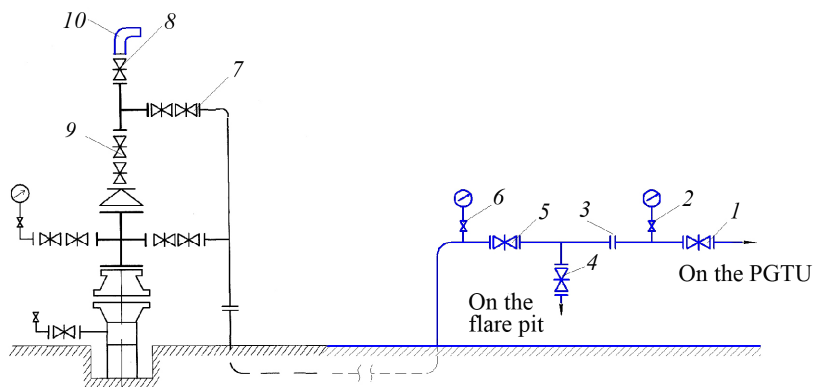

Fig. 3. Diagram of the well-control equipment and distribution manifold of well 116 of the Khidnovytske GF: 1, 4, 5, 7, 8, 9 – valves; 2, 6 – pressure gauge valves; 3 – flange diaphragm connections; 10 – blow-down elbow

force the pig through to the wellhead onto the blowdown elbow.

The forcing through of the pig resulted in the passage of the apparent gas-liquid flow. Then some water “packs”, in which small pig parts were noticeable, were removed. The process of purging the pipeline lasted for about 15 min.

Organization and sequence of the operations on cleaning the pipeline of well 118 from the fluid accumulations with the help of the viscoelastic pig were carried out in the following way:

- a) the well was shut down, the flowline valve of the well-control equipment and the master valve were closed, and the gas was bled from the space between them;
- b) the buffer flange was removed and the prepared pig was inserted into the space, wherefrom the gas had been bled;
- c) the flowline end valves were closed before and after the measuring diaphragm and the gas was bled from the space between them;
- d) the measuring diaphragm was removed and the flanges without the diaphragm were mounted;
- e) when opening the valves 9, 7, 5, and 1 one-by-one (Fig. 4), the well was brought into operation onto the GTU;
- f) the measuring diaphragm was mounted onto the gas treatment unit after one hour of the well operation.

**Explanation of scientific results.** The results of the input parameters measuring, required for evaluation of the

efficiency of the conducted pilot tests of the viscoelastic pig application, are shown in Table 2.

According to the results of the pilot tests, after the application of the technology for cleaning the pipelines of wells 118 and 116 from the fluid accumulations with the help of the viscoelastic pig, the gas flow rate of well 118 increased by 0.8 thousand m<sup>3</sup>/day (8 %) and the flow rate of well 116 increased by 0.3 thousand m<sup>3</sup>/day (20 %).

**Conclusion.** The operation of the gathering system in the Khidnovytske GF becomes more complicated due to the fluid accumulations in the lowered sections of the flow lines. The conducted calculations of the hydraulic-pressure losses in the gathering system are indicative of the significant excess of the actual hydraulic resistance coefficients over the theoretical one in the pipelines of most wells. This results in increase in the pressure at the wellhead and decrease in the production capacities of the wells and up to the cessation of their natural flowing.

In order to clean the pipelines of the wells from the fluid accumulations, it was proposed to use the water-soluble viscoelastic pig. Therefore, the necessity to equip the pipelines of the wells with the chambers for receiving the cleaning devices is redundant. Besides, the introduction of the gel pig into the gas pipeline is possible both via the special launching chambers or flange connections of the well-control equipment (if they are demounted beforehand) and via the buffer flange of the well-control equipment with the help of the pumping unit.

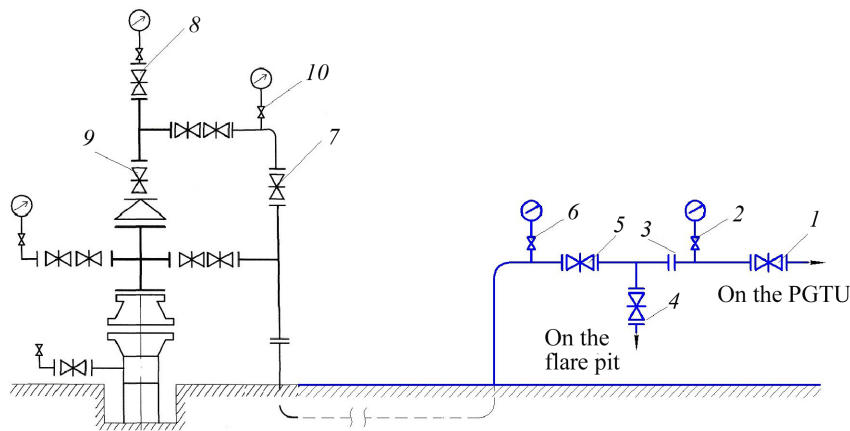

Fig. 4. Diagram of the well-control equipment and distribution manifold of well 118 of the Khidnovytske GF:  
1, 4, 5, 7, 8, 9 – valves; 2, 6 – pressure gauge valves; 3 – flange diaphragm connections

Table 2

Input parameters and results of the pilot tests of the viscoelastic pig application for cleaning the pipelines of wells 116 and 118 of the Khidnovytske GF from the fluid

№	Well number	Before the operations			After the operations			Flow rate increase thousand m <sup>3</sup> /day
		gas pressure, MPa		gas flow rate, thousand m <sup>3</sup> /day	gas pressure, MPa		gas flow rate, thousand m <sup>3</sup> /day	
		at the pipeline beginning	at the pipeline end		at the pipeline beginning	at the pipeline end		
1	2	3	4	5	6	7	8	9
1	118	0.23	0.2	9.5	0.212	0.2	10.3	0.8
2	116	0.23	0.2	1.5	0.205	0.2	1.8	0.3

According to the results of the pilot tests, the gas flow rates increased by 0.8 thousand  $\text{m}^3/\text{day}$  (8 %) and 0.3 thousand  $\text{m}^3/\text{day}$  (20 %) respectively as a result of cleaning the pipelines of wells 116 and 118 of the Khidnovytske GF from the fluid. The results of the conducted studies are indicative of the efficiency of the viscoelastic pig application for cleaning the pipelines of the wells from the fluid accumulations.

#### References.

1. Skrylnyk, K. Y., Mukhammed Haleb Naser Al-Shammar and Krymov, A. P., 2015. Analysis of technologies for improving the efficiency of the system of gas gathering. *Integrated technologies and energy saving*, 1, pp. 7–13.
2. Sheina, Z. V., Sobolieva, A. V. and Ruzina, I. M., 2011. Analysis of technological measures to prevent operation complications of the objects of the linear portion of the gas pipelines that operate in depletion. *Development issues of the Ukrainian gas industry: collection of scientific papers of the Ukrainian Scientific and Research Institute of Natural Gases*, XXXIX, pp. 258–265.
3. Honcharov, V. M., Melnyk, A. P., Kostenko, L. O., Dehtiarov, O. A. and Honcharov, M. V., 2010. On the foam cleaning technology and inhibition of the gas field and gas transportation equipment. *Development issues of the Ukrainian gas industry: collection of scientific papers of the Ukrainian Scientific and Research Institute of Gases*, XXXVIII, pp. 1799–1840.
4. Bratakh, M. I., Kusturova, O. V., Ruzina, I. M. and Krymov, A. P., 2013. Modeling of the purification of flow lines. *Integrated technologies and energy saving*, 4, pp. 9–14.
5. Bratakh, M. I., Skrylnyk, K. Y. and Burova, M. Y., 2013. Synthesis of the task of transporting polyphase media by a pipeline system. *Integrated technologies and energy saving*, 4, pp. 38–44.
6. Uhrynovskyi, A. V., Kondrat, R. M. and Himer, P. R., 2013. Mathematical model of the fluid accumulation in the lowered gas pipeline section. *Naukovyi Visnyk Nationalnoho Hirnychoho Universytetu*, 4, pp. 36–41.
7. Porada, Y. R. and Horal, L. T., 2011. The main tendencies of development and improvement of intrarenal devices. *Scientific reporter IFNTUNG*, 1(27), pp. 87–90.
8. Kondrat, R. M., Uhrynovskyi, A. V., Petryshak, V. S. and Sapozhkova, T. S., 2013. Characterization and selection of the cleaning devices for cleaning of the internal pipeline cavity. *Prospecting and development of oil and gas fields*, 3(48), pp. 46–61.

**Мета.** Підвищення гідравлічної ефективності шлейфів газових і газоконденсатних свердловин шляхом очищення їх внутрішньої порожнини від скупчень рідини.

**Методика.** Поставлені завдання вирішувалися шляхом проведення експериментальних досліджень із визначення часу розчинення в'язкопружного поршня у воді та воді з конденсатом за різного вмісту поверхнево-активної речовини. Для визначення ефективності застосування в'язкопружного поршня проводились відповідні дослідно-промислові випробування на шлейфах свердловин Хідновицького газового родовища.

**Результати.** Для умов Хідновицького газового родовища розраховані теоретичні й фактичні значення коефіцієнта гідравлічного опору викидних ліній свердловин. Встановлені шлейфи свердловин, в яких виникають додаткові втрати тиску за рахунок накопичення рідини в понижених ділянках. Для боротьби з водяними корками у шлейфах свердловин запропонована технологія застосування в'язкопружного поршня, що є розчинним у воді та складається з вітчизняних хімічних реагентів. Після використання запропонованої технології сумарний дебіт газу збільшився на 1,1 тис.  $\text{m}^3/\text{доб}$ .

**Наукова новизна.** Розроблена технологія очищення викидних ліній свердловин від скупчень рідини за допомогою в'язкопружного поршня, на основі водного розчину карбоксиметилцелюлози й поверхнево-активної речовини з можливістю регулювання часу деструкції полімерної системи.

**Практична значимість.** Запропонована технологія може бути використана для очищення внутрішньої порожнини шлейфів низьконапірних газових і газоконденсатних свердловин і промислових газопроводів від скупчень рідини. У результаті забезпечується стабільна робота свердловини з підвищеними дебітами газу й конденсату.

**Ключові слова:** *очисний пристрій, в'язкопружний поршень, поверхнево-активна речовина, газопровід, свердловина*

**Цель.** Повышение гидравлической эффективности шлейфов газовых и газоконденсатных скважин путем очистки их внутренней полости от скопленной жидкости.

**Методика.** Поставленные задачи решались путем проведения экспериментальных исследований по определению времени растворения вязкоупругого поршня в воде и воде с конденсатом с разным содержанием поверхностно-активного вещества. Для определения эффективности применения вязкоупругого поршня проводились соответствующие опытно-промышленные испытания на шлейфах скважин Хидновицкого газового месторождения.

**Результаты.** Для условий Хидновицкого газового месторождения рассчитаны теоретические и фактические значения коэффициента гидравлического сопротивления выкидных линий скважин. Установлены шлейфы скважин, в которых возникают дополнительные потери давления за счет накопления жидкости в пониженных участках. Для борьбы с водяными пробками в шлейфах скважин предложена технология применения вязкоупругого поршня, который является растворимым в воде и состоит из отечественных химических реагентов. После использования предложенной технологии суммарный дебит газа увеличился на 1,1 тыс.  $\text{m}^3/\text{сут}$ .

**Научная новизна.** Разработана технология очистки шлейфов скважин от скопленной жидкости с помощью вязкоупругого поршня, на основе водного раствора карбоксиметилцеллюлозы и поверхностно-активного вещества с возможностью регулирования времени деструкции полимерной системы.

**Практическая значимость.** Предложенная технология может быть использована для очистки внутренней полости шлейфов низконапорных газовых и газоконденсатных скважин и промышленных газопроводов от скоплений жидкости. В результате обеспечивается стабильная работа скважины с повышенными дебитами газа и конденсата.

**Ключевые слова:** очистное устройство, вязкоупругий поршень, поверхностно-активное вещество, газопровод, скважина

Рекомендовано до публікації докт. техн. наук І.І. Чудиком. Дата надходження рукопису 12.10.16.

UDC 622.281.74

DOI: 10.29202/nvngu/2018-1/18

R. M. Tereshchuk, Cand. Sc. (Tech.), Assoc. Prof.,  
[orcid.org/0000-0003-4509-2511](https://orcid.org/0000-0003-4509-2511),  
 N. V. Khoziaikina, Cand. Sc. (Tech.), Assoc. Prof.,  
[orcid.org/0000-0002-4747-3913](https://orcid.org/0000-0002-4747-3913),  
 D. V. Babets, Cand. Sc. (Tech.), Assoc. Prof.,  
[orcid.org/0000-0002-5486-9268](https://orcid.org/0000-0002-5486-9268)

National Mining University, Dnipro, Ukraine, e-mail: tereschuk.rm@gmail.com

## SUBSTANTIATION OF RATIONAL ROOF-BOLTING PARAMETERS

Р. М. Терещук, канд. техн. наук, доц.,  
[orcid.org/0000-0003-4509-2511](https://orcid.org/0000-0003-4509-2511),  
 Н. В. Хозяйкина, канд. техн. наук, доц.,  
[orcid.org/0000-0002-4747-3919](https://orcid.org/0000-0002-4747-3919),  
 Д. В. Бабець, канд. техн. наук, доц.,  
[orcid.org/0000-0002-5486-9268](https://orcid.org/0000-0002-5486-9268)

Державний вищий навчальний заклад „Національний гірничий університет“, м. Дніпро, Україна, e-mail: tereschuk.rm@gmail.com

## ОБҐРУНТУВАННЯ РАЦІОНАЛЬНИХ ПАРАМЕТРІВ АНКЕРНИХ СИСТЕМ

**Purpose.** To analyse a state of border rock mass of permanent slope mine working in the process of roof-bolting mounting. To determine rational roof-bolting density as well as length of anchors in the deepening process in the context of  $m_4^2$  seam of *Pioneer* mine (“DTEK Dobropolliavuhillia” Ltd).

**Methodology.** Roof-bolting parameters for the permanent slope mine workings were substantiated while analysing regularities of changes in behaviour and stress-strain state of rock mass and identifying displacements of rock contour of a mine working. Thereupon, rational values of anchor lengths and roof-bolting density based upon them were determined. To analyse changes in the behaviour and stress-strain state of border rock mass of permanent inclined mine working with roof-bolting, a finite-element method was applied.

**Findings.** A method to analyse both behaviour and stress-strain state of border rock mass of permanent inclined mine workings in the context of roof-bolting mounting has been substantiated. The procedure of the problem solution while using developed software has been described. Calculation model to solve a problem concerning the determination of rational roof-bolting density and anchor lengths to support permanent inclined mine workings in the context of their depth changes has been developed. Rational parameters of roof-bolting while supporting permanent inclined mine workings under specific mining and geological conditions have been determined.

**Originality.** Graphs of dependences of roof rock border displacements and floor of permanent inclined mine working on its depth in terms of anchor length and roof-bolting density have been obtained.

**Practical value.** Results of the studies may be used at the design stage to forecast displacements of a roof, a floor and walls of permanent inclined mine workings under the conditions of  $m_4^2$  seam at *Pioneer* mine to optimize roof-bolting parameters.

**Keywords:** *inclined mine working, mathematical modelling, roof bolting, mine*

**Introduction.** Over recent years mining depth of coal deposits has experienced significant deepening; moreover, mining and geological conditions have deteriorated. Maintenance of permanent mine workings in such a situation being the essential condition of safe underground operations as well as sustainability of high technical-and-economic indices of coal-mining enterprises involves con-

siderable expenses connected with repair-and-renewal operations.

As a rule, Ukrainian mines use metallic arched flexible supports made of special shape to reinforce both permanent and development underground mine workings. Arched three-link support is the most popular among all support types. However, the available metallic arched flexible supports prevent permanent inclined mine workings from keeping them in operating conditions during the