

UDC 621.314.6

<https://doi.org/10.29202/nvngu/2019-5/16>

O. A. Plakhtii¹, Cand. Sc. (Tech.), Assoc. Prof.,
orcid.org/0000-0002-1535-8991,
V. P. Nerubatskyi¹, Cand. Sc. (Tech.), Assoc. Prof.,
orcid.org/0000-0002-4309-601X,
V. Ye. Kavun¹,
orcid.org/0000-0002-9411-5567,
D. A. Hordiienko²,
orcid.org/0000-0002-0347-5656

1 – Ukrainian State University of Railway Transport, Kharkiv, Ukraine, e-mail: a.plakhtiy1989@gmail.com; NVP9@i.ua; vi-taliykavun2014@gmail.com

2 – Private JSC “ELAKS”, Kharkiv, Ukraine, e-mail: D.Hordiienko@i.ua

ACTIVE SINGLE-PHASE FOUR-QUADRANT RECTIFIER WITH IMPROVED HYSTERESIS MODULATION ALGORITHM

Purpose. Improvement of the hysteresis control system which, thanks to the advanced switching power switch algorithm, allows reducing dynamic losses in comparison with known hysteresis control systems.

Methodology. Simulation of an active four-quadrant converter in the Matlab/Simulink program. Mathematical analysis of the Fourier spectrum of the input current.

Findings. Simulation modeling proves the effectiveness of the proposed modulation algorithm by reducing the number of switching power switches. In addition, during the implementation of the proposed switching algorithm, an improvement in the harmonic composition of the input current is observed, namely, the decrease in the amplitudes of the higher harmonics of the input current and the reduction of the resulting harmonic distortion coefficient.

Originality. It is established that the proposed improved hysteresis control system of the active four-quadrant converter by means of short-circuited states of power switches allows reducing the total number of times of switching power switches, and accordingly, dynamic losses in the active converter, which allows increasing the efficiency of the input transducer of the electric rolling stock.

Practical value. The proposed improved hysteresis control system, thanks to the advanced switching power switch algorithm, reduces dynamic losses to 33 %.

Keywords: *active four-quadrant converter, 4QS-converter, hysteresis modulation, dynamic losses, energy efficiency, power quality*

Introduction. Existing diode and thyristor rectifiers used in traction drives of the electric rolling stock are obsolete and require modernization [1].

At present, the use of active four-quadrant voltage rectifiers is promising. Their advantages include the possibility of implementing a power factor close to one, the possibility of forming an input current close to the sinusoid, and also realizing the mode of energy recovery to the power supply [2, 3]. Hysteresis control system of these converters have become quite widespread. However, the disadvantage of hysteresis modulation in active rectifiers is the need for the implementation of a variable and a fairly high switching frequency in power switches: from units to tens of kilohertz [4, 5].

Literature review. The diode and thyristor four-arc rectifiers used on alternating current of the electric rolling stock cause a significant emission of higher harmonics of current and implement a rather low power factor ranging from 0.65 to 0.85, which significantly reduces the energy efficiency of the electric rolling stock and the whole traction power system [6]. In turn, the presence of a significant reactive power component in the traction network leads to the need to use rather expensive reactive power compensators produced according to the passive or active topology [7].

Promising is the application of active four-quadrant rectifiers of the electric rolling stock with the correction of the

power factor known as 4QS-converters [8]. Unlike traditional thyristor rectifiers, 4QS-converters have a number of significant advantages [9] since they:

- provide the shape of the consumed current, close to the sinusoid;
- realize a power factor close to one;
- provide low emission of higher harmonics of the consumed current to the power supply (the harmonic distortion factor can be provided below 5 %);
- realize bilateral transmission of electric energy;
- provide regulation and stabilization of the voltage in the circuit of direct current.

The power scheme of the traction electric drive of the electric rolling stock of an alternating current with a 4QS-converter, which feeds the voltage source inverter (VSI) and a traction asynchronous motor (AD), is shown in Fig. 1.

In Fig. 1 the active four-quadrant rectifier consists of a LI choke, which acts as a buffer reactor to increase the output voltage, IGBT-transistors $VT1 \div VT4$, capacitive filter $C1$ designed to reduce the output voltage pulsation amplitude and the $C2-L2$ rejector filter used to suppress the output voltage harmonic 100 Hz.

Most commonly used in 4QS-converters were control systems built on the basis of pulse-width and hysteresis modulation [10, 11]. Each of these systems has its advantages and disadvantages.

The advantage of control systems built on the basis of pulse-width modulation (PWM) is the possibility of setting a

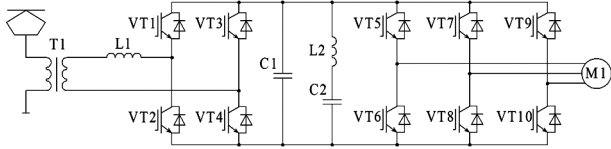

Fig. 1. Power circuit of the electric rolling stock of an alternating current with a 4QS-converter

constant modulation frequency. However, there are drawbacks, namely the reduction of the range of regulation of the output voltage and deterioration of the quality of electric energy [12]. The advantage of hysteresis control systems is their relative simplicity and the ability to implement rather high quality electrical energy performance indicators. The disadvantage of existing hysteresis control system is the presence of sufficiently high and variable switching power switches, which results in high dynamic losses in the converter [13, 14]. In this case, the switching frequency of a 4QS-converter with a hysteresis control system depends on many factors: the value of the input inductance of the converter, the load current and the value of the hysteresis setting [15].

Purpose. The purpose of the study is to develop a switching algorithm for power switches of the 4QS-converter, which implements the formation of an input current close to the sinusoid, with a reduced number of switching power switches and, accordingly, with reduced dynamic losses and improved efficiency. Confirmation of reliability of reduction of dynamic losses is carried out by simulation in Matlab program.

Basic hysteresis control system. The structure diagram of the basic hysteresis control system is shown in Fig. 2, in which the following notations are adopted: u_{in} – the instantaneous value of the input voltage; u_{out} – the mean square value of the output voltage; i_{in} – instantaneous significance of the input current; i_{in}^* – a signal for setting the instantaneous value of the input current; u_{out_set} – a signal of output voltage setting; ξ – the control coefficient of the control system; i_{out} – the mean-square value of the output current; $S_{VT1}, S_{VT2}, S_{VT3}, S_{VT4}$ – control signals of the corresponding transistors [16].

The principle of formation of the sinusoidal input current of the 4QS-converter with the base (known) hysteresis control system (Fig. 3) consists in comparing the input signal i_{in}^* , obtained as the instantaneous value of the scaling using the control coefficient ξ of the input voltage u_{in} , with the instantaneous value of the input current i_{in} and the error signal Δi . Next, in the block of the hysteresis modulator, the comparison of the error signal Δi with the given hysteresis setting h is realized. Given $\Delta i > h$, that is, when the instantaneous value of the current exceeds its signal of the task by the value of h , then the control system provides the activation signals for a pair of power transistors $VT1$ and $VT4$, which causes the switching of the input current with a decrease in its instantaneous value. And then, provided $\Delta i < -h$, that is, the value of the instantaneous value of the input current in relation to its reference signal by the value of h , the control system provides the activation signals for a pair of power transistors $VT2$ and

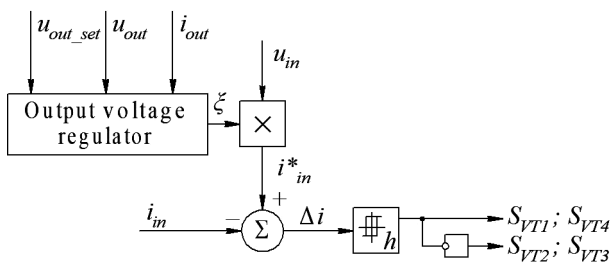

Fig. 2. The structure diagram of the basic hysteresis control system

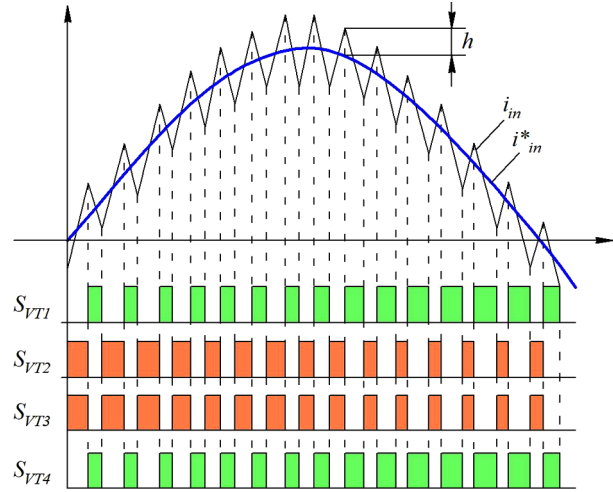

Fig. 3. Sinewall input current of a 4QS-converter with base hysteresis control system

$VT3$, which causes an increase in the instantaneous value of i_{in} . Thus, it is achieved to create a sinusoidal current corridor [17].

If the pair of transistors $VT1$ and $VT4$ is switched on to the input choke from the side of the active converter, the voltage of the DC circuit $+u_{out}$ is applied, which is higher than the amplitude value of the input voltage, which facilitates the succession of the instantaneous value of the input current. Conversely, turning on the pair of transistors $VT2$ and $VT3$ contributes to an increase in the instantaneous value of the input current. Thus, in the case of each switching of the input current, all four power switches are switched, which, given the rather high switching frequency, causes quite significant dynamic losses in the converter.

Improved hysteresis control system. An improved hysteresis modulation algorithm is synthesized in an active four-quadrant converter, which allows reducing the number of times of switching power switches and, thus, reducing the dynamic losses in the converter. The switching states of the simultaneous activation of a pair of transistors $VT1$ and $VT3$ and a pair of $VT2$ and $VT4$ are suggested in the sequence of switching of power switches, which, due to the positive input voltage polarity, contribute to the growth of the instantaneous value of the input current, and in the case of negative polarity, they facilitate its recession. This allows for a positive half-wave of the input voltage to switch from the switching position $VT1-VT4$ to the state $VT1-VT3$. In this case, the instantaneous value of the input current varies from declining to rising, but unlike the basic switching algorithm, in this case, only two power switches are switched. In the case of negative polarity u_{in} it is also possible to use short-circuited positions: switching from the switching position $VT2-VT3$ to $VT1-VT3$.

The proposed enhanced switching algorithm for power switches consists of six switching positions as shown in Table 1, where the gray color depicts the stages of the switching of the input current in which there is no switching of the corresponding power switches.

The principle of formation of the sinusoidal input current of the 4QS-converter with the proposed hysteresis control system is shown in Fig. 4.

It should be noted that the advantage of the proposed algorithm is that all four switches of the modulation algorithm have the same dynamic losses.

As can be seen from Fig. 4, the proposed switching algorithm makes it possible to reduce the number of switches, which reduces the overall dynamic losses in the switches of the 4QS-converter with a hysteresis control system up to 33 %, which increases its efficiency coefficient.

Determination of power losses in power switches. To deter-

Switching sequence of power IGBT-transistors with improved hysteresis modulation

Power switch	Switching position of power IGBT-transistors with positive polarity of input voltage						Switching position of power IGBT-transistors with negative polarity of input voltage					
	0	1	1	1	0	1	1	0	1	0	0	0
VT1	0	1	1	1	0	1	1	0	1	0	0	0
VT2	1	0	0	0	1	0	0	1	0	1	1	1
VT3	1	0	1	0	0	0	0	1	1	1	0	1
VT4	0	1	0	1	1	1	1	0	0	0	1	0
$i_{in}(t)$	grow	fall	grow	fall	grow	fall	fall	grow	fall	grow	fall	grow
Step	step 1	step 2	step 3	step 4	step 5	step 6	step 1	step 2	step 3	step 4	step 5	step 6

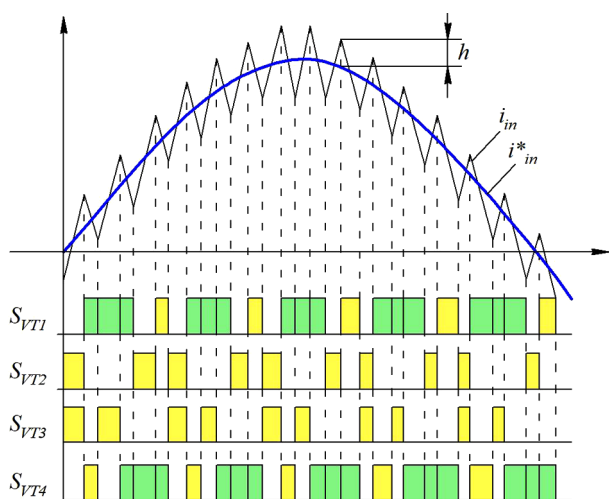

Fig. 4. Sinewall input current of a 4QS-converter with the proposed hysteresis control system

mine the energy-saving effect from the implementation of the improved hysteresis modulation algorithm, the calculation of power losses in the active four-quadrant converter at its output voltage of 3000 V is carried out.

The calculation is made using power IGBT-switches with nominal voltage of 4500 V type CM1200HG-90G [18].

The basic parameters of the transistor CM1200HG-90G are shown in Table 2.

The oscillograms of the switching current and voltage are shown in Fig. 5, a. Fig. 5, b shows power dissipation of a power IGBT-transistor during switching.

In calculations, total power losses in power transistors are divided into two components: static and dynamic losses [19].

$$P = P_{DC} + P_{SW}, \tag{1}$$

where P_{DC} is the static losses in IGBT-transistors; P_{SW} is the dynamic losses in IGBT-transistors.

Static power losses of P_{DC} in power IGBT-transistors are determined according to the expression

Table 2

The parameters of the transistor CM1200HG-90G

Parameter	Value
Voltage between collector and emitter, V	4500
Voltage gate-emitter, V	± 20
Acceptable constant load current, A	1200
Permissible pulsed current, A	2400
Voltage of isolation, V	10 200
Permissible temperature of the transistor, °C	-50 ÷ 150

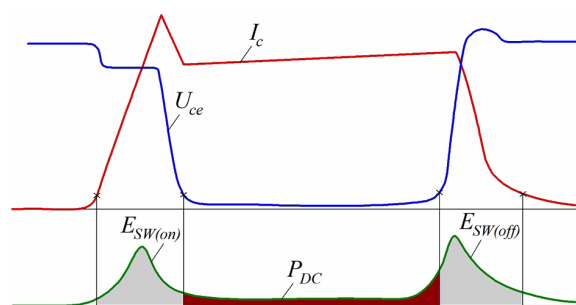

Fig. 5. The process of switching current and voltage (a) and power dissipation power of an IGBT-switch (b)

$$P_{DC} = U_{ce} \cdot I_c \cdot \alpha, \tag{2}$$

where U_{ce} is the voltage drop between the collector and emitter of the transistor; I_c is the collector current of the transistor; α is the fill factor at modulation.

Dynamic power losses of P_{SW} in power IGBT-transistors are determined according to the expression

$$P_{SW} = (E_{on} + E_{off}) \cdot f, \tag{3}$$

where E_{on} is the energy dissipated in the transistor when it is switched on; E_{off} is the energy dissipated in the transistor when switched off; f is the switching frequency of power switches.

Based on the calculations, the basic power characteristics of the power transistor were constructed. Fig. 6 shows the voltage dependence between the collector and the emitter on the load current. In Fig. 7 the dependence of the switching energy of the transistor on the load current is shown.

Table 3

Parameters of the simulation model

Parameter	Value
Discretization of the calculation time of the simulation model, μs	1
Permissible error of modeling, %	0.1
Amplitude value of the input voltage of the active four-quadrant converter, V	600
The value of the adjustment coefficient ξ	2.5
Input inductance, mH	0.8
Active resistance of the input inductance, mΩ	15
Capacity of the filter in DC circuit, mF	3
Rated voltage in DC circuit, V	1500
The mean square load current of the active converter, A	590
Traction motor parameters by type	CTA1200

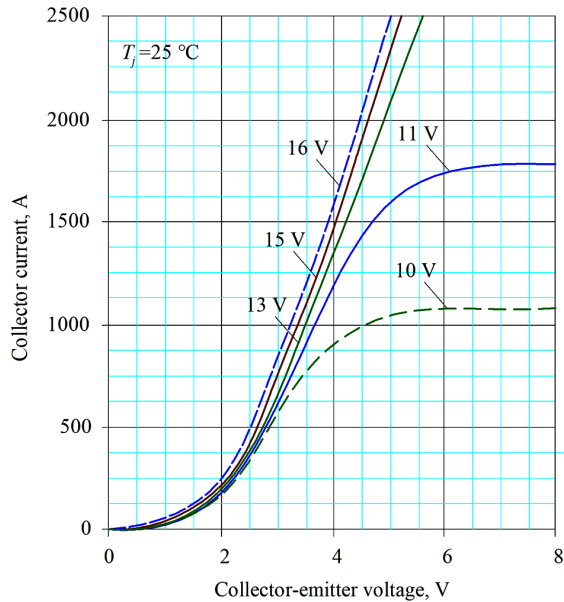

Fig. 6. The dependence of the voltage between the collector and the emitter on the load current

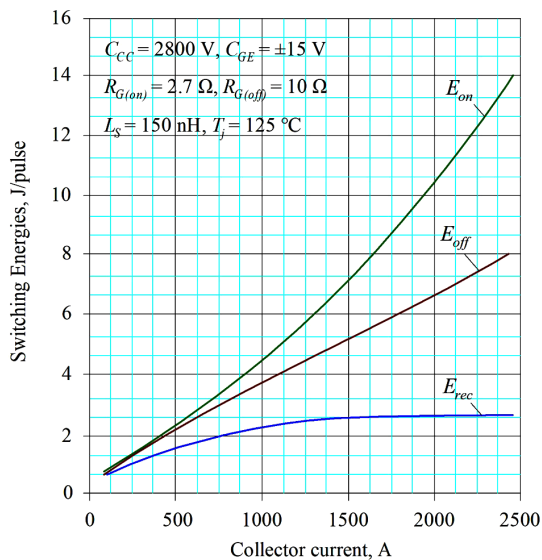

Fig. 7. Dependence of the energy of switching the transistor on the load current

The results of the calculation of power losses for classical hysteresis modulation and improved hysteresis modulation are given in Table 4.

Results of simulation modeling

Parameter	Basic control system	Improved control system
Average switching frequency of the power switches for the power supply period, kHz	14.21	10.22
Coefficient of harmonic distortions of the input current, %	1.90	1.86
Power factor, %	99.96	99.98
Average switching frequency of power switches on period, Hz	2520	1250
Loss of power in one transistor, W	11.9	7.65
Coefficient power factor, %	93	95

The performed calculations show that the use of the proposed switching of power switches allows reducing power losses in power switches.

Simulation modeling. In order to confirm the proposed theoretical principles, reduce the dynamic losses and compare the realized quality energy parameters in an active four-quadrant converter with basic and improved hysteresis modulations, an imitation model of the 4QS-AIN-AD electromechanical system was developed in Matlab (Fig. 8).

In the simulation model, basic and improved hysteresis control systems with an active four-quadrant converter are implemented. The basic parameters of the simulation model are given in Table 3.

In order to estimate the dynamic losses in the power transistors of the active four-quadrant converter, a counter of the signals of switching on and off the power switches is inserted into the model [20].

It should be noted that the use of the proposed switching power switch for the implementation of hysteresis modulation leads to a decrease in the amplitudes of higher harmonics of the input current and the simultaneous expansion of its spectrum. The results of imitation modeling of the traction electric drive system are shown in Fig. 9.

The simulation parameters are shown in Table 4.

The obtained results of imitation modeling have confirmed the reduction of the number of times of switching of power switches, and accordingly, the reduction of dynamic losses. Due to the fact that the switching frequency of the power switches is variable, its evaluation was performed at the average value of the supply voltage.

In the case of classical hysteresis, the average switching frequency of power switches for the period of power supply voltage was 14.2 kHz, and for improved hysteresis control system – 10.22 kHz.

Conclusions. The proposed improved hysteresis control system of the active four-quadrant converter through the use

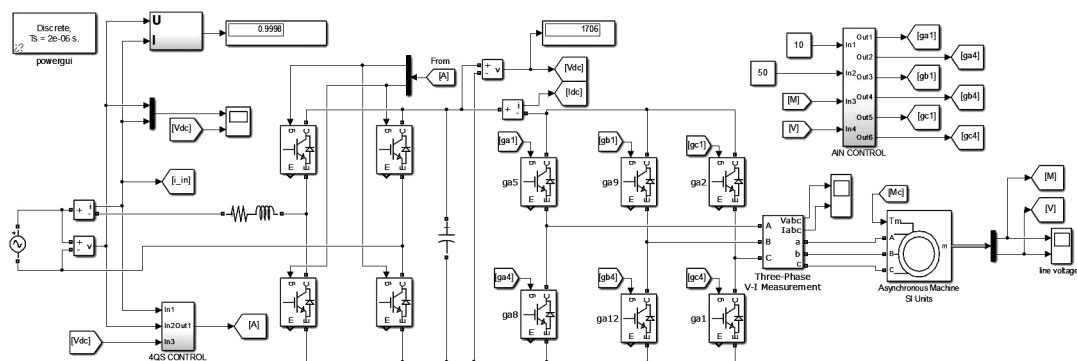

Fig. 8. The simulation model of the 4QS-AIN-AD electromechanical system

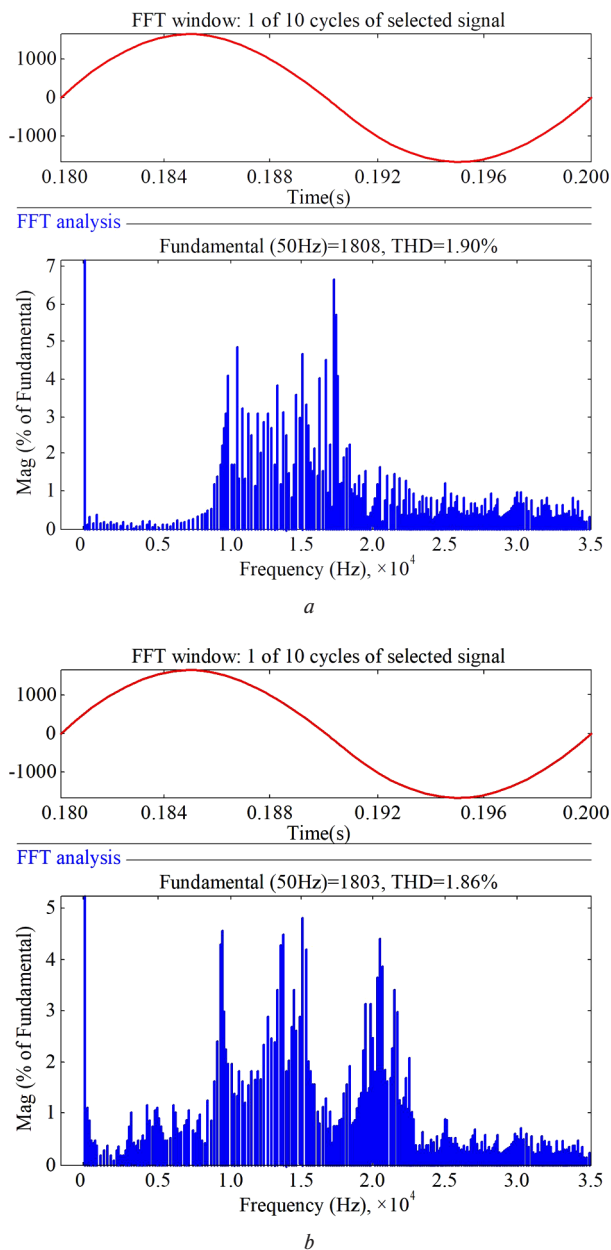

Fig. 9. Simulation of the traction electric drive system:
 a – Fourier analysis of the input current of the active rectifier with the base hysteresis control system; b – Fourier analysis of the active current rectifier with an improved hysteresis control system

of short-circuited states of power switches allows reducing the total number of times of switching of power switches, and, accordingly, reducing dynamic losses in the active converter, which allows increasing the efficiency of the input converter of the electric rolling stock significantly.

The results of the simulation model confirmed the effectiveness of the proposed modulation algorithm, namely the reduction of the number of times of switching power switches by 28.07 %. In addition, during the implementation of the proposed switching algorithm, a slight improvement of the harmonic composition of the input current is observed, namely, the decrease in the amplitudes of the higher harmonics of the input current and the reduction of the resulting coefficient of harmonic distortion.

References.

1. Blahnik, V., & Talla, J. (2016). Single-phase synchronization for traction active rectifier. *International Conference on Applied Electronics (AE)*. DOI: 10.1109/ae.2016.7577233.

2. Fomin, O.V., Lovska, A.O., Plakhtii, O.A., & Nerubatskiy, V.P. (2017). The influence of implementation of circular pipes in load-bearing structures of bodies of freight cars on their physico-mechanical properties. *Naukovyi Visnyk Natsionalnoho Hirnychoho Universytetu*, 6, 89-96.

3. Plakhtii, O., Nerubatskiy, V., Ryshchenko, I., Zinchenko, O., Tykhonravov, S., & Hordiienko, D. (2019). Determining additional power losses in the electricity supply systems due to current's higher harmonics. *Eastern-European Journal of Enterprise Technologies*, 1(8(97)), 6-13. DOI: 10.15587/1729-4061.2019.155672.

4. Arcega, F.J., & Pardina, A. (2014). Study of harmonics thermal effect in conductors produced by skin effect. *IEEE Latin America Transactions*, 12(8), 1488-1495. DOI: 10.1109/TLA.2014.7014518.

5. Gervasio, F., Mastromauro, R., & Liserre, M. (2015). Power losses analysis of two-levels and three-levels PWM inverters handling reactive power. *IEEE International Conference on Industrial Technology (ICIT)* (pp. 1123-1128). DOI: 10.1109/icit.2015.7125248.

6. Pillay, T., & Saha, A. (2017). Analysis and simulation of flying capacitor multilevel inverter using PDPWM strategy. *International Conference on Innovative Mechanisms for Industry Applications (ICIMIA)* (pp. 1061-1070).

7. Shcherbak, Ya.V., Plakhtii, O.A., & Nerubatskiy, V.P. (2017). Regulatory characteristics of the active quadrature converter in regimens and recuperation modes. *Technical electrodynamics*, (6), 26-31. DOI: 10.15407/techne2017.06.026.

8. Ahmadzadeh, T., Sabahi, M., & Babaei, M. (2017). Modified PWM control method for neutral point clamped multi-level inverters. *14th International Conference on Electrical Engineering / Electronics, Computer, Telecommunications and Information Technology (ECTI-CON)* (pp. 765-768). DOI: 10.1109/ECTICon.2017.8096351.

9. Dai, P., Guoand, G., & Gong, Z. (2016). A Selection Pre-charge Method for Modular Multilevel Converter. *International Journal of Control and Automation*, 9(4), 161-170.

10. Plakhtii, O.A., & Nerubatskiy, V.P. (2018). Analyses of energy efficiency of interleaving in active voltage-source rectifier. *2018 IEEE 3rd International Conference on Intelligent Energy and Power Systems (IEPS)* (pp. 253-258). DOI: 10.1109/IEPS.2018.8559514.

11. Zhao, G.I., Wang, L., Li, Q., & Chen, G. (2014). Analyze and compare the efficiency of two-level and three-level inverter in SVPWM. *9th IEEE Conference on Industrial Electronics and Applications* (pp. 1954-1958). DOI: 10.1109/iciea.2014.6931488.

12. Vasil'ev, B.Yu. (2015). Providing overmodulation mode and increasing energy conversion efficiency in autonomous power inverters of electric drives. *Electricity*, (6), 47-55.

13. Rodder, S., Biswas, M., & Khan, Z. (2016). A modified PWM technique to improve total harmonic distortion of multi-level inverter. *9th International Conference on Electrical and Computer Engineering (ICECE)* (pp. 46-54). DOI: 10.1109/ICECE.2016.7853970.

14. Borrega, M., Marroyo, L., Gonzalez, R., Balda, J., & Agorreta, J.L. (2013). Modeling and control of a master-slave PV inverter with n-paralleled inverters and three-phase three-limb inductors. *IEEE Transactions on Power Electronics*, 28(6), 2842-2855. DOI: 10.1109/TPEL.2012.2220859.

15. Khanchi, S., & Garg, V. (2013). Unified power flow controller: a review. *International Journal of Engineering Research and Applications*, 3(4), 1430-1435.

16. Zhemerov, G.G., Tugay, D.V., & Titarenko, I.G. (2013). Simulation of AC drives system comprising multilevel inverter. *Electrical Engineering and Electromechanics*, (2), 40-47.

17. Lazzarin, T., Bauer, G., & Barbi, I. (2013). A control strategy for parallel operation of single-phase voltage source inverters: analysis, design and experimental results. *IEEE Transactions on Industrial Electronics*, 60(6), 2194-2204. DOI: 10.1109/TIE.2012.2193856.

18. Ferdowsi, F., Yazdankhah, A., & Rohani, H. (2014). A combinative method to control output power fluctuations of large gridconnected photovoltaic systems. In *Environment and Electrical Engineering (EEEIC)* (pp. 260-264).
19. Dias, R. A., Lira, G. R., Costa, E. G., Ferreira, R. S., & Andrade, A. F. (2018). Skin effect comparative analysis in electric cables using computational simulations. *2018 Simposio Brasileiro de Sistemas Eletricos (SBSE)* (pp. 1-6). DOI: 10.1109/SBSE.2018.8395687.
20. Ferdowsi, F., Edrington, C., & Elmezyani, T. (2015). Real-time stability assessment utilizing non-linear time series analysis. In *North American Power Symposium (NAPS)* (pp. 1-6).

Активний однофазний чотириквадрантний випрямляч із покращеним алгоритмом гістерезисної модуляції

О. А. Плахтій¹, В. П. Нерубацький¹, В. Є. Кавун¹,
Д. А. Гордієнко²

1 – Український державний університет залізничного транспорту, м. Харків, Україна, e-mail: a.plakhtiy1989@gmail.com; NVP9@i.ua; vitaliykavun2014@gmail.com

2 – ПрАТ „ЕЛАКС“, м. Харків, Україна, e-mail: D.Hordiienko@i.ua

Мета. Покращення гістерезисної системи керування, що, завдяки удосконаленому алгоритму комутації силових ключів, дає змогу знизити динамічні втрати в порівнянні з відомими гістерезисними системами керування.

Методика. Моделювання у програмі Matlab/Simulink активного чотириквадрантного перетворювача. Математичний апарат аналізу Фур'є спектра вхідного струму.

Результати. Імітаційне моделювання підтверджує ефективність запропонованого алгоритму модуляції за рахунок зниження числа перемикань силових ключів. Крім того, під час реалізації запропонованого алгоритму комутації спостерігається покращення гармонічного складу вхідного струму, а саме зниження амплітуд вищих гармонік вхідного струму та зниження результуючого коефіцієнта гармонічних спотворень.

Наукова новизна. Встановлено, що запропонована покращена гістерезисна система керування активного чотириквадрантного перетворювача, за рахунок використання короткозамкнених станів силових ключів, дає змогу знизити загальну кількість комутацій силових ключів, а, відповідно, й динамічні втрати в активному перетворювачі, що дає змогу збільшити ККД вхідного перетворювача ЕРС.

Практична значимість. Запропонована покращена гістерезисна системи керування, завдяки вдосконаленому алгоритму комутації силових ключів, знижує динамічні втрати до 33 %.

Ключові слова: активний чотириквадрантний перетворювач, 4QS-перетворювач, гістерезисна модуляція, динамічні втрати, енергоефективність, якість електроенергії

Активный однофазный четырёхквадрантный выпрямитель с улучшенным алгоритмом гистерезисной модуляции

А. А. Плахтий¹, В. П. Нерубацкий¹, В. Е. Кавун¹,
Д. А. Гордиенко²

1 – Украинский государственный университет железнодорожного транспорта, г. Харьков, Украина, e-mail: a.plakhtiy1989@gmail.com; NVP9@i.ua; vitaliykavun2014@gmail.com

2 – ЧАО „ЭЛАКС“, г. Харьков, Украина, e-mail: D.Hordiienko@i.ua

Цель. Улучшение гистерезисной системы управления, которая, благодаря усовершенствованному алгоритму коммутации силовых ключей, позволяет снизить динамические потери по сравнению с известными гистерезисными системами управления.

Методика. Моделирование в программе Matlab/Simulink активного четырехквадрантного преобразователя. Математический аппарат анализа Фурье спектра входного тока.

Результаты. Имитационное моделирование подтверждает эффективность предложенного алгоритма модуляции за счет снижения числа переключений силовых ключей. Кроме того, при реализации предложенного алгоритма коммутации наблюдается улучшение гармонического состава входного тока, а именно снижение амплитуд высших гармоник входного тока и снижение результирующего коэффициента гармонических искажений.

Научная новизна. Установлено, что предложенная улучшенная гистерезисная система управления активного четырехквадрантного преобразователя, за счет использования короткозамкнутых состояний силовых ключей, позволяет снизить общее количество коммутаций силовых ключей, а, соответственно, и динамические потери в активном преобразователе, что позволяет увеличить КПД входного преобразователя ЭДС.

Практическая значимость. Предложенная улучшенная гистерезисная система управления, благодаря усовершенствованному алгоритму коммутации силовых ключей, снижает динамические потери до 33 %.

Ключевые слова: активный четырёхквадрантный преобразователь, 4QS-преобразователь, гистерезисная модуляция, динамические потери, энергоэффективность, качество электроэнергии

Рекомендовано до публікації докт. техн. наук
О. С. Крашенініним. Дата надходження рукопису 28.08.18.