

Odessa national Academy of Telecommunications, Kuznechnaya Street 1, Odessa 65029, Ukraine,
phone/fax: +38-048 -7236118, E-mail: kurmask12@gmail.com

BRIDGE SENSORS BASED ON FIELD-EFFECT TRANSISTORS

Possibility of the use of the field-effect transistors is considered in the bridge sensors of the magnetic field, temperature and light. It is shown that maximum sensitivity is attained in the sensor bridge circuit, where the elements in the four arms of the bridge field effect transistors are used, and one pair of transistors current increases with the growth of measured value, and the other - is decreased.

Keywords: sensor, bridge circuit, field-effect transistor

1. Introduction

The base of measuring systems is represented by the primary sensors. They transform input physical values (temperature, pressure, illumination, magnetic flux, acceleration etc.) into proportional electrical output signal [1]. One of the features of parametric sensors is changing of parameters of electrical, magnetic, optical circuits – resistance, inductance, capacity, light penetration and others. They are passive (i.e. allow to make indirect conclusions about the physical value by connecting the sensor to the electrical circuit) and need a power supply. The effect of active resistance changing frequently is used in such sensors (thermorestive, photoresistive and magnetic-resistive effects), changing of permittivity, light transmittance and so on.

When connecting resistive sensors bridge circuits in many cases are used. In such measuring circuits eliminates the main drawback of most of measuring circuits with voltage dividers – presence of non-zero output signal with absence of signal on input of the measuring circuit. As is known, bridge measuring scheme has two arms: the measuring arm in which the parametrical sensor is included, and the base one. When the bridge is connected, voltage is given on one of its diagonals, and output signal is read from the other. In non-equilibrium bridge mode in the initial state

bridge is balanced, that is, the output signal is set to zero value.

During the further deviation of resistances (impedances) from their initial values a non-zero output signal is formed. Depending on the number of measuring transformers (primary sensors), there are quarter-bridge, half-bridge and full-bridge sensor schemes. To decrease non-linearity of the output characteristic, we apply differential connection to a bridge scheme of measuring transformers, having sensitivities opposite in sign to each other [2]. The weakness of the well-known resistivity (impedance) sensors is their little sensitivity to weak input signals. The purpose of this work is to study the possibilities to increase the sensitivity of parametrical sensors based on bridge schemes by using elements with internal amplification (field-effect transistors -FET).

1. Magnetic field sensors

In a semiconductor placed inside a magnetic field we can observe a magnetic-resistive effect, which shows itself in decreasing charge carriers' mobility and, correspondingly, increase of electric resistance of the material. It completely refers to the channel of the field-effect transistor placed into a transversal magnetic field [3]. In this case, same as in a magnetoresistor, the channel length should be much less than its width. An example that satisfies this condition is FET with *n*-type channel and *p-n*-junction as a gate. When the

FET operates as a primary transformer it is usually connected as a dipole (the gate connected to the source, voltage on the gate $U_g=0$). In this case, saturation current of the FET is defined as

$$I_s = An^2 \mu, \quad (1)$$

where n, μ - concentration and mobility of charge carriers in a channel, A - constant that is defined by geometrical and electrical parameters of channel that depend on voltage [3]. Change of current I_s of such FET in a magnetic field with induction up to 0.5 T is about 1% and, in this case, is of no practical interest as a sensor output parameter.

The most preferable as a sensor is a scheme of two FET, one of them is a magnetosensitive element (MFET), the other one operates as a load. Such scheme is shown on fig. 1. Current-voltage characteristics (CVC) of MFET with such load and the load curve are shown on fig. 2. Here E is the supply voltage. As a result of small angle between voltage axis and CVC in the area of current saturation, a small change of saturation current will lead to significant change of voltage on MFET: from U_0 to U_B . Two FET with similar saturation current are selected for the sensor scheme. When magnetic field is absent (inductance $B=0$), the supply voltage E is equally divided between two FET, and $U_0=E/2$. When MFET is placed into a magnetic field that is perpendicular to current direction, the resistance of channel increases, while the saturation current decreases. This leads to increase of voltage on MFET till it reaches the value U_B . Unlike the magnetoresistors' operation, this process is accompanied by internal mechanism of sensitivity increase. This is caused by the fact that resistance of any FET in the area of CVC saturation increases with the increase of voltage, as with increase of voltage U the current I_s slightly increases. Thus, increase of MFET channel resistance leads to increase of voltage drop U_B , and this causes additional increase of channel resistance and increase of U_B .

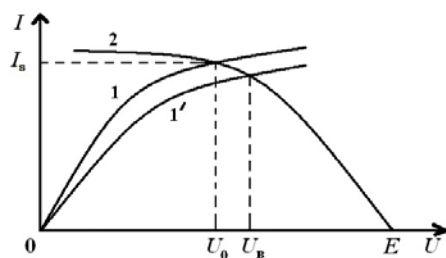

Figure 1. Scheme of the magnetosensitive element with two field-effect transistors: 1 –MFET, 2 – FET.

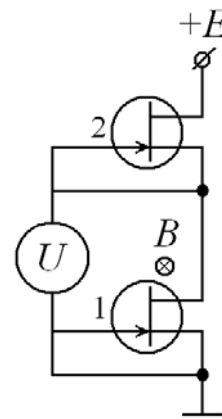

Figure 2. Voltage-current characteristics of MFET: 1 – magnetic field is absent; 1' – with active magnetic field; 2 – load curve.

For the output voltage of sensor to be measured from zero a bridge scheme is used (fig. 3) where another pair of FET (load FET) is connected to a pair of MFET transistors. Two MFET are located in opposite arms of the bridge, load FET – also in the opposite arms. Trimmer alternating resistor R_x serves for precise specification of zero (bridge balancing) when the magnetic field is absent. Besides the obvious doubling of magnetic sensitivity (in comparison to one sensitive element), such half-bridge scheme of four FET (two of them are magnetosensitive) allows to remove the temperature zero drift of zero of the output voltage and to reduce the temperature coefficient of magnetic sensitivity to values less than 0.1 %/°C. Dependence of output voltage U on magnetic inductance B is shown on fig. 4. It is clear that this voltage increases with increase of induction B and increase of supply voltage E . Magnetic sensitivity $\gamma=U/I \cdot B$ for bridge sensors based on FET is $\sim 5 \cdot 10^3$ V/A · T, which is 50 times greater than for Hall's silicon sensors.

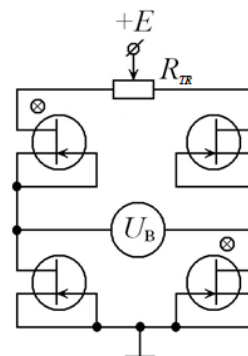

Figure 3. Bridge scheme of the magnetosensitive actuator.

We also notice that in contradiction to magnetoresistors, magnetic sensitivity of FET-based sensors is maximal in the range of weak magnetic fields, while the magnetoresistors have the minimal one.

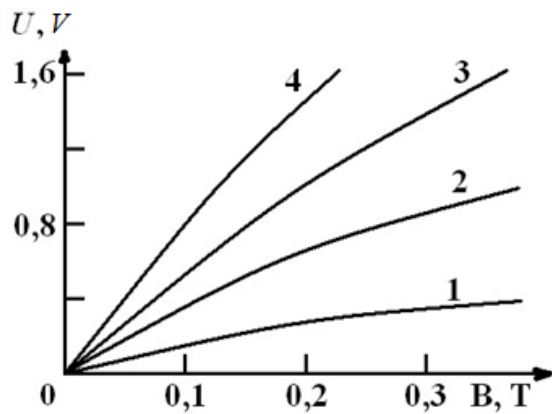

Figure 4. Dependence of output voltage U on magnetic induction B . Supply voltage E , B : 1 -10, 2 -15, 3 -20, 4 -25.

If we place both MFT (fig. 3) into an inhomogeneous magnetic field, the output signal will be proportional to difference between the inductions of magnetic field in two points of location of FET channels. Such sensor can be used for measuring of gradient of an inhomogeneous magnetic field.

1. Temperature sensors

Field-effect transistors can be used as temperature sensors. The maximal sensitivity of the bridge sensor can be obtained in case all the four components are elements sensitive to the measured value and their sensitivities are opposite in sign (fig. 5). The current of the first pair of elements (situated in opposite arms of the bridge) should increase with growth of this value, and the current of the second pair (situated in the other two arms) should increase. For a bridge with such scheme of connection of primary transformers, voltage of the signal on the measuring diagonal is

$$U = \frac{E \Delta R}{R} \quad (2)$$

Here E – voltage circuit of the bridge, R – channel resistance of transistor in a circuit “source-drainage”, ΔR – change of this resistance with the change of temperature. As the first pair we used FET (T_1) with p - n -junction as a gate. Their

saturation current I_s decreases with growth of temperature, as a result of recession of charge carriers’ mobility in the channel [3]. Metal-oxide-semiconductor (MOS) transistor (T_2) were connected as a second pair. Their current I_s increases with the increase of temperature. This is due to increasing gate voltage cut-off when changing the charge on the surface states under the gate [4].

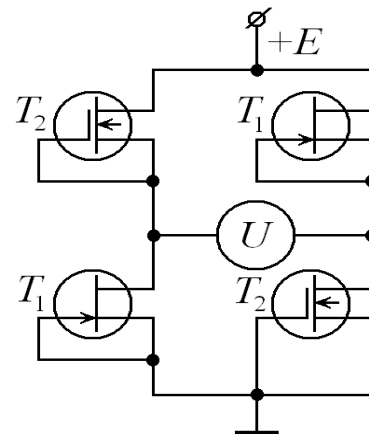

Figure 5. Bridge temperature sensor.

Expansion of linear range $U=f(T)$ can be performed by introducing a resistor R_s into every FET source. Figure 6 shows dependence of output voltage of the bridge that is balanced at a temperature $T=0^\circ\text{C}$. Sensitivity of bridge is $\sim 1\text{ V}/^\circ\text{C}$ at f supply voltage $E=20\text{ V}$ and $R_s=0$ in the temperature range of $(-10\dots+10)^\circ\text{C}$ (curve 1). Outside this range sensitivity decreases and non-linearity of $U=f(T)$ dependence increases.

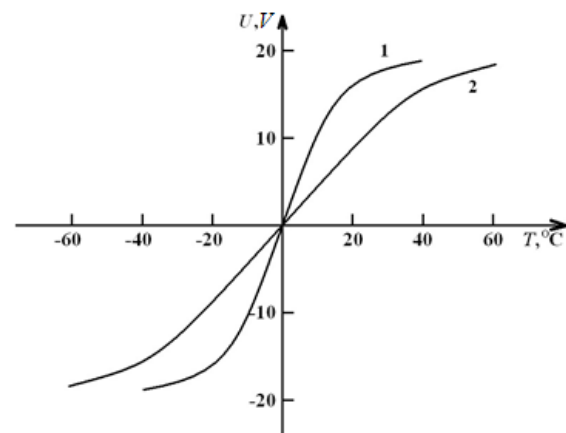

Figure 6. Dependence of output voltage on temperature. Resistance of FET source circuit R_s , $\text{k}\Omega$: 1 – 0; 2 – 1.

At $R_s=1\text{ k}\Omega$ the dependence $U=f(T)$ is linear in the range of $(-35\dots+35)^\circ\text{C}$, and sensitivity decreases to the value $0.3\text{ V}/^\circ\text{C}$ (curve 2). The same resistors can be used to balance the bridge at any given temperature. It is known that the thermosensitivity of a FET-based bridge is 10...100 times higher than the one for bridge sensors based on other elements [5].

2. Photodetecting devices

A full-bridge sensor model, in which the current that flows through one FET pair increases with external influence and decreases when it flows through another pair, can also be used to create a photodetecting device (PhDD). Fig. 7 shows the structures of two types of MOS-FET-phototransistors. Transistor of first type PhT_1 (fig. 7a) is a simple MOS-FET with built-in channel based on semiconductor of n -type conductivity with two contacts (S – source, DR - drainage) with a dielectric (D) and a metallic gate (G), connected to the source. When the structure is lightened from the side of semitransparent metallic gate G, the light is absorbed in the channel, the concentration of charge carriers in it increases, and the current through PhT_1 increases. The transistor PhT_1 can also be lightened from the opposite side of the channel, i.e. from the side of the substrate.

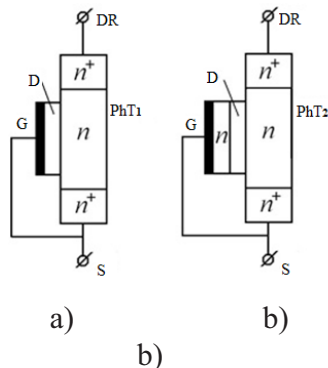

Figure 7. MOS-FET with built-in channel (a), with the n -type semiconductor between the gate and the dielectric (b).

The main difference between the transistor PhT_1 and the transistor of the second type PhT_2 (fig. 7b) is the presence of a layer of n -type semiconductor between the metallic layer of the gate and the dielectric. The contact metal-semiconductor (gate) is a Schottky diode (SD). When

this structure is lightened from the side of semi-transparent metal, a photo-EMF appears in SD with metal as a “plus” and semiconductor as “minus”. This photo-EMF stands for the input signal for PhT_2 transistor and reduces concentration of charge carriers in the channel. As a result, the current through PhT_2 decreases with lightning. In this case all the light is absorbed in the n -layer and never reaches the channel.

The sensor operation can be explained with the help of the scheme (fig. 8). When there is no lightning, resistance on all phototransistors in the bridge arms is the same. The applied voltage E is distributed equally to PhT_1 and PhT_2 . The potentials U_1 and U_2 in the measuring diagonal of the bridge are equal, and the output signal $U_{\text{out}} = U_1 - U_2 = 0$, that means the bridge is balanced. In real life, phototransistors usually have scattered parameters, that's why the bridge should be balanced with the help of trimmer resistor R_{tr} or the resistors in the circuits of the sources. Lightning of PhDD by a stream Φ causes decrease of PhT_1 resistance and increase of PhT_2 resistance. This leads to misbalancing of the bridge, potential U_1 increases, potential U_2 decreases, i.e. the output signal $U_{\text{out}} = U_1 - U_2$ increases with increase of light stream Φ .

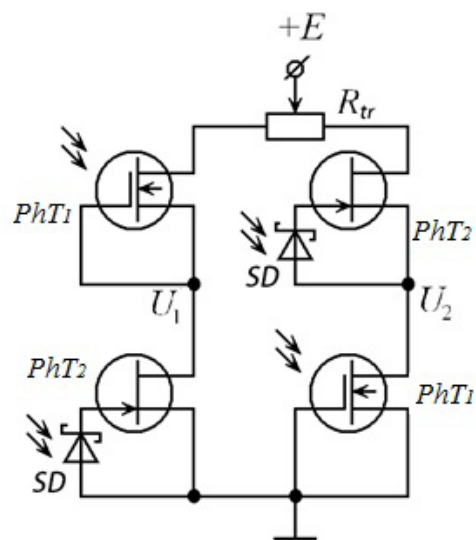

Figure 8. The scheme of a bridge photosensor (PhDD).

Experimental samples of PhDD were made based on serial MOS-FET-transistor (PhT₁) with a structure shown in fig. 7a. With the source-drainage voltage $U_{S-DR} = 10V$ and a closed gate, channel resistance is $\sim 10 k\Omega$. The main difference between PhT₁ and PhT₂ is the presence of a layer of *n*-type semiconductor between the metallic layer of gate and the dielectric. The thickness of this layer should be such that all the light would be absorbed in it and didn't reach the channel. The lightning of phototransistors was made by a "green" light-emitting diode (maximal light emission at wavelength $\lambda = 0.56 \mu m$). The maximal lightening power reached 0.6 mW with the current through the light-emitting diode 100 mA. Photosensitivity of PhDD experimental samples at $E=20 V$ was 10...100 times greater than the one of photodetectors based on photodiodes and bipolar transistors [5].

Results

To sum up, we shall note that bridge schemes are also applied for construction of pressure sensors. Silicon membranes are widely used as pressure sensors. They are represented by a plate with four diffusion tensoresistors that form a measuring bridge [2]. We have observed that replacing the resistors by field transistors also allows to sig-

nificantly improve sensitivity of pressure sensors.

Using FET in measuring bridges allows to increase sensitivity of sensors, to reduce energy consumption, and to provide stability of measuring devices.

References

1. Sharapov V. M., Vikulin I. M., Kurmashev Sh. D., Sensors, Cherkassy Brama, - 2008.- pp 430-470 .
2. V. A. Teslenko, Actuators in data and management collecting systems// Journal of Industrial measurements, control, automatics, diagnostics 2004, 2 (1), pp 50-56.
3. Vikulina L. F., Glauberman M.A., Physics of the temperature and magnetic field sensors, Odessa Lighthouse.- 2000-17-123 pp.
4. A. I. Krivonosov, Semiconductor temperature actuators. Moscow, Energy.- 2004 -156 p.
5. Vikulin I.M., Kurmashev Sh.D., Stafeev V.I., Injection-based photodetectors// *J. Semiconductors* 2008, 42 (1), pp 112-127.

This article has been received within 2014

UDC 621. 317

I. M. Vikulin, Sh. D. Kkurmashhev. A. V. Veremyova

BRIDGE SENSORS BASED ON FIELD-EFFECT TRANSISTORS

Abstract

Possibility of the use of the field transistors is considered in the bridge sensors of the magnetic field, temperature and light. It is shown that maximum sensitivity is attained in the sensor bridge circuit, where the elements in the four arms of the bridge field effect transistors are used, and one pair of transistors current increases with the growth measured value, and the other - is decreased.

Key words :field transistors, bridge sensors, maximum sensitivity.

УДК 621. 317

И. М. Викулин, Ш. Д. Курмашев, А. В. Веремьева

МОСТОВЫЕ ДАТЧИКИ НА ОСНОВЕ ПОЛЕВЫХ ТРАНЗИСТОРОВ

Резюме

Рассмотрена возможность использования полевых транзисторов в мостовых датчиках магнитного поля, температуры и света. Показано, что максимальная чувствительность достигается в мостовых схемах датчиков, где в качестве всех четырех элементов в плечах моста используются полевые транзисторы, причем у одной пары транзисторов ток увеличивается с ростом измеряемой величины, а у другой – уменьшается.

Ключевые слова: полевые транзисторы, мостовые датчики, максимальная чувствительность.

УДК. 621. 317

И. М. Вікулін, Ш. Д. Курмашев, Г. В. Вереміова

МОСТОВІ ДАТЧИКИ НА БАЗІ ПОЛЬОВИХ ТРАНЗИСТОРОВ

Резюме

Розглянуто можливість використання польових транзисторів в мостових датчиках магнітного поля, температури та світла. Показано, що максимальна чутливість досягається в мостових схемах датчиків, де в якості всіх чотирьох елементів в плечах моста використовуються польові транзистори, причому в одній парі транзисторів струм збільшується із зростанням вимірюваної величини, а в іншій – зменшується.

Ключові слова: польові транзистори, мостові датчики, максимальна чутливість.