

РЕЗУЛЬТАТИ ЕКСПЕРИМЕНТАЛЬНИХ ДОСЛІДЖЕНЬ

UDK 621.891

R. Kaczyński, DSc, PhD, MSc Professor

WORKING MEDIUM AS THE WORKING ENVIRONMENT FOR THE CONSTRUCTION OF MINI-GENERATOR OF ELECTRIC ENERGY

Bialystok University of Technology

SUMMARY. Monitoring systems for water distribution and sewerage networks constitutes an indispensable condition for smooth operational management of existing communal infrastructure. The question of an effective use of resources and means to supervise, regulate, and control water supply networks requires special care already in the planning stage and also during the implementation process of maintenance equipment. To meet the above demand a telemetry and data system to monitor the performance of water mains has been developed making use of GSM/GPRS data transfer technology. One of the fundamental problems of building the system is how to supply energy to the distributed control and measurement devices. A possible solution to these problems could be, as proposed in this paper, a wireless energy supply system using the measuring medium, i.e. the flowing water for energy transport. To this end, a construction of a mini-hydrodynamic generator, i.e. a device transforming the kinetic energy of flowing water into electrical energy using carbon polymers reinforced with carbon fibres has been made, in which the flow of the operational medium is the working environment.

This solution will allow for a continuous collection of small amounts of energy to charge the built-in measuring device batteries. Energy storage will be used for ongoing measurement and periodic data transfer.

Introduction. The present article attempts to solve two integral sub-tasks related to the construction of mini-generator of electric energy, namely:

- working out the relationship between comparable tribological pairs which employ plastic components applicable in construction of among others the bearings of a mini-generator of electric energy where the working environment is constituted by the working medium;
- investigating the optimum form and construction of mini-turbine.

Monitoring systems for water distribution and sewerage networks constitutes an indispensable condition for smooth operational management of existing communal infrastructure. The question of an effective use of resources and means to supervise, regulate, and control water supply networks requires special care already in the planning stage and also during the implementation process of maintenance equipment. Considering the large scale of distribution of water and sewerage systems, the problem of simultaneous reading of a large number of measurement results gains special importance. The problem can be resolved by the application of an efficacious method for gathering and processing of the measurement data obtained from a random number of distributed nodes in the network by means of GSM/GPRS technology. One of the essential issues in the design of such a system is supplying power to control and measurement instruments in various locations. Presently, this can be achieved by the following means:

- 1) supplying power directly to the measurement points, which is expensive and requires planning permissions and pre-arrangements;
- 2) equipping measurements devices in batteries of high capacity allowing for several years' operation, which is a convenient but expensive solution. Besides, this solution does not ensure constant access to the devices and data, due to the periodical operation of the devices (the devices enter a power-save mode);
- 3) using replaceable and rechargeable batteries, which requires additional effort.

An attractive alternative for the above-mentioned solutions can be a wireless power supply which makes use of the working medium – that is, of the flowing water. For this purpose, construction of hydro-generator was suggested, a device which transforms kinetic energy of flowing water into electric energy. This would provide continuous power supply allowing the built-in batteries of measurement instruments to charge. Moreover, stored up electric energy can be used for the purpose of running measurements and for periodic data transfers. Essentially, the difficulties arising in construction of such devices are: insufficient data concerning the form and size of mini-turbines used in this kind of generators, as well as lack of information related to the problems of insulation and bearing of slide elements, the choice of friction pairs working in the flowing medium and the evaluation of their durability.

The models of mini-turbines proposed here base on the modernized construction of water mini-turbines used in water meters. To the author’s knowledge, presently there are no unambiguous research results available relating to this kind of mini-turbines propelled by the stream of water in a sewage flow. Thus, for the needs of the present project the acquisition of own data is planned by means of experiments conducted on the research site with the installed mini-generator device.

The manufacturers of power mini-generators, that is devices generating electric current from mechanical vibrations of surface, temperature differences, light, etc. have recently noted abrupt increase in sales. Mini-generators are used for powering wireless sensors, the products which in last few years have been developing at an astonishing rate. According to Darnell Group’s report, the market of mini-generators might be relatively small thus far, but nonetheless it is characterized by an impressive growth rate averaging to 65% per year. Until the year 2010 about 200 million of these devices are to be released. Companies such as Advanced Linear Devices (USA), EnOcean (Germany), and Perpetuum (Great Britain) hold the greatest share in the market.

Methodology of tribological analysis. Experimental research was carried out with the use of two kinds of friction pairs, whose materials used as samples for investigation were structurally very similar. The samples with the pin diameter equal 3mm. were made of the following composite materials reinforced with carbon fiber:

- SIGMA3, the composite material of Saint Petersburg industrial plants, used for lubricating screw propeller shafts and having the following properties (Table 1):

Table 1

| Trade name | Density [g/cm ³] | Brinell HardnessNumber | Relative stretchability[%} | Temperature range[°C] |
|------------|------------------------------|------------------------|----------------------------|-----------------------|
| SIGMA-3 | 1,5 | 100 | 14 | (-40) – (+140) |

- Quadrant EPP Ketron® PEEK CA30 Polyetheretherketone, 30% carbon fiber with the following properties (Table 2):

Table 2

| Trade name | Density [g/cm ³] | Brinell HardnessNumber | Relative stretchability[%} | Temperature range[°C] |
|------------------|------------------------------|------------------------|----------------------------|-----------------------|
| KETRON PEEK CA30 | 1,41 | 325 | 5 | Up to +250 |

As a countersample a circle-shaped piece 25,4 mm. in diameter of LH 15 bearing steel described in PN standard (100Cr6 in EN) was used.

The analysis was conducted on a T-11 tribometer with a pin-on-disc friction. The constant parameters of the test runs included: sample initial run time (running in) $t=10\text{min}$. (under the pressure of 0.71MPa); main test run time $t=2\text{h}$; slide velocity $v=1\text{m/s}$; four values of individual pressure p within the range of $2.8\text{--}13.5\text{MPa}$. The whole test procedure was repeated three times for each of the stresses.

Also, the test runs were conducted in three different mediums: in water, in the air, and in SAE 15W/40 oil. The parameters continuously monitored during the whole research were: friction force $F[\text{N}]$; temperature measured in the area of friction contact $T[^\circ\text{C}]$; and linear wear of the samples $z[\mu\text{m}]$. Additionally, the total mass wear of the samples was evaluated; its value was measured each time before and after the test.

Results of the tribological analysis. The results of experimental analysis are presented in Fig. 1. The graphs present relationships between the tribological parameters as a function of stress (2.8 ; 4.2 ; 8.5 ; and 13.5 MPa) in three environments (water, air, SAE 15W/40 oil) for the following friction pairs: SIGMA3-LH15 (Figs.1a, 1c, 1e) and PEEK CA30-LH15 (Figs.1b, 1d, 1f).

The microscopic examination and analysis of chemical composition was carried out with the aid of a Hitachi S-3000N Scanning Electron Microscope (equipped with a QUEST type EDS X-Ray Microanalysis System). The obtained microscopic pictures of surface layers, as well as the chemical composition of selected areas of the surface made it possible to carry out an in-depth analysis of friction processes and identification of wear mechanisms occurring in the particular environments (due their large volume the data are not quoted here).

Comparing all the graphs gained through the experimental analysis, it can be noticed that their features for either friction factor, temperature, or linear wear is in most of the cases very similar.

A good example of the similarity is the shape of friction factor μ curves in the oil environment obtained for the both friction pairs.

Scrutinizing the received results, it might be assumed that the both investigated materials can work in comparable conditions, but in a rather narrow stress range. The couple SIGMA3-LH15 working in water conditions stands clearly out, which suggests using it for the construction of slide elements in the mini-generator.

The analysis of friction and wear processes together with investigation of chemical composition and examination of pictures of surface layers structures of samples made of SIGMA3 and PEEK CA30 after friction in water environment allow for a claim that there exist substantial differences in the operational characteristics of the studied friction pairs and in the mechanisms of wear in comparison to the samples operating in oil.

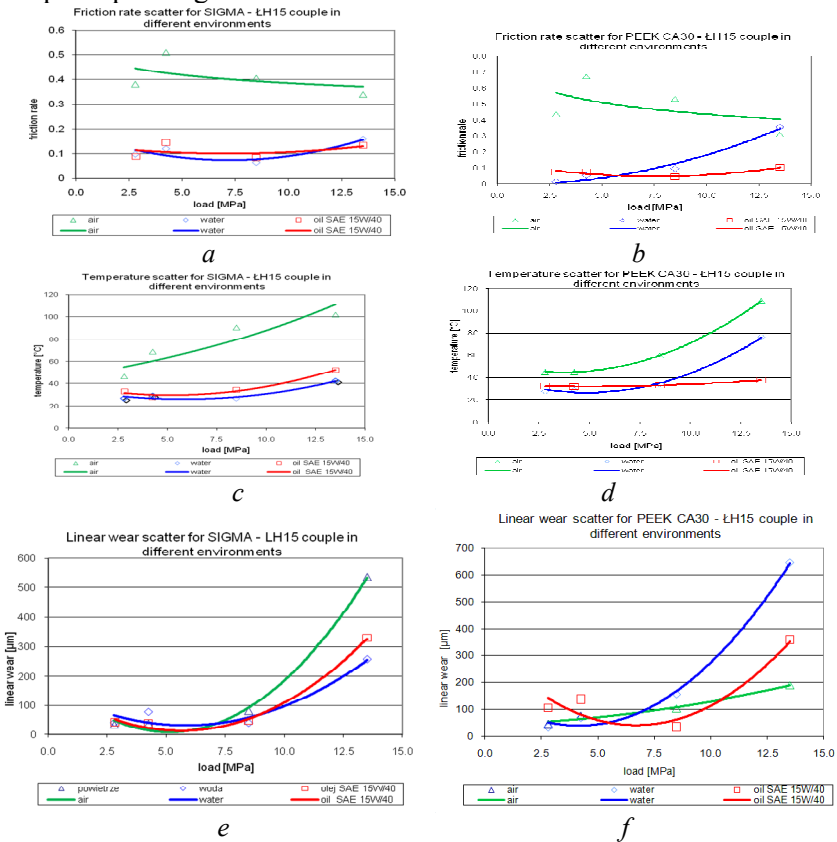

Fig. 1. Dependencies between friction factor (*a, b*), temperatures in the area of friction contact (*c, d*), and linear wear (*e, f*) respectively for SIGMA3-LH15 and PEEK CA30-LH15 pairs, and stress in the three environments (water, air, SAE 15W/40 oil)

Visible carbon fibers, as well as scarce traces of secondary structures (or the lack of them) point out to abrasion as the dominant

form of wear in samples functioning in the air and in water. This is further confirmed by a low content of oxygen and other elements that could form oxygen compounds (Fe, Ca, Si, Na) in the surface layer. The dominant form of wear in oil, i.e. in the chemically active environment, is a mechanical-chemical wear. The mechanism of erosion of the surface layers of the investigated composite material samples is a subject of separate study.

Structural models of the mini-turbine. Figs. 2 and 3 present general variants of mechanical solutions for the construction of a turbogenerator propelled by energy of the medium flowing through a pipeline. In the initial stage of the whole undertaking, employing integrated turbogenerator design (i.e. the turbine and generator constituting one integral element) should be considered. In the case when the generator's dimensions are much larger in comparison to the turbine's (insufficient power of the turbine), it is reasonable to use drive transmission system (2) from the turbine (1) to the generator (3) installed outside the pipeline. If the generator's power obtained from the turbine installed through an opening in a pipe is too low, the application of devices installed by means of flange joints should be taken into account, which allows for utilization of the entire flow surface.

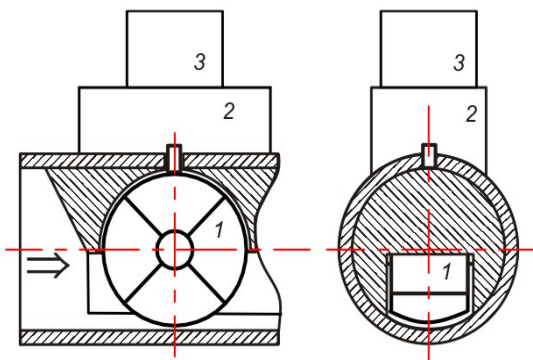

Fig. 2. Hydrogenerator with the turbine's axle perpendicular to the direction of the flow. The turbine is placed in the pipe's axis, where 1 – turbine, 2 – drive transmission system, 3 – generator

The constructions installed through an opening in a pipe wall meet all the requirements for universality of application and ease of assembly. However, they demand rather elaborate constructional and technological approach in their design and implementation. Thus, the solution with the devices installed by means of a flange joint seems to be the simplest one. It considerably simplifies the functioning both of the system as a whole and of the system's individual components. Also, such an approach makes it possible to benefit from the already existing designs and prefabricated elements. On top of that, it allows to fully exploit the energy of water from the whole flow surface in a pipe.

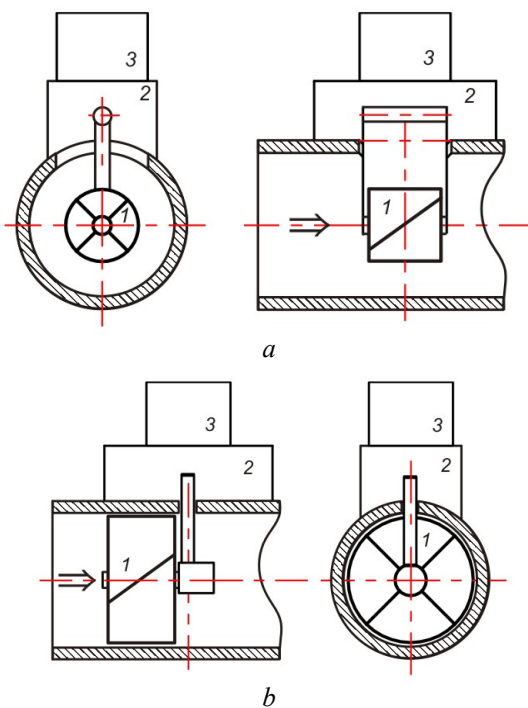

Fig. 3. Hydrogenerator with the turbine's axle parallel to the direction of the flow. The turbine is placed in placed in the pipe's axis (or close to it) – (a) installation through a hole in the wall of the pipe, (b) the devices mounted by means of a flange joint, where 1 –turbine, 2 – drive transmission system, 3 –generator

The technical approach relying on transformation of the energy of the flowing medium and transferring the torque outside the pipe – as presented in Figs. 2 and 3 – is commonly applied in, for instance, in propeller and turbine water meters. However, the specific operational character of water meters may preclude the use of the ready-made mechanism for the purpose of the power generator. Water meters, as a rule, should be most of all marked by a high sensitivity and possibly low flow resistance. The torque generated by the turbine in a water-meter sets in motion a dainty and consuming little energy mechanism of a counter. This would be definitely not enough to propel a 5W power generator. Hence, only several of the solutions used in water meters may be implemented in practice.

A hydrogenerator with a turbine axle perpendicular to the direction of the flow, such as presented in Fig. 2, has a lower efficiency than a generator with a turbine axle placed in the axis of a pipe as described above. But it is characterized by a low sensitivity to pollution, relatively high torque at low rotation velocity, and its turbine blades are easily shaped. The torque of the turbine depends among others on the rotor's radius. Accordingly, the inside area of the rotor might be used to install a miniature gear and a generator.

Construction of a prototypical hydrodynamic mini-generator of electric energy. Construction of three different prototypes has been planned according to the diagrams in Figs. 2 and 3, specifically:

- 1) a prototype with a water-meter-type rotor with blades (Fig. 4);
- 2) a prototype with a water-meter-type propeller (Fig. 5);
- 3) a prototype with the generator directly after the turbine.

In the implementation of the first two prototypes, the entire water-meter driving system will be adapted for the purpose, including casing, rotors, guide wheels, fastenings, bearings, and sealings. As for the rotor driving shaft, it will be coupled with the direct current generator driving shaft whose terminals will be connected with the terminals of charged batteries. Additionally, the electric system will be equipped with a multimeter.

The described conception of the project will result in the minimization of efforts related to the construction of the rotor turbine, impeller, and at the same time will allow to focus on the drive transfer system with all the related tribological issues.

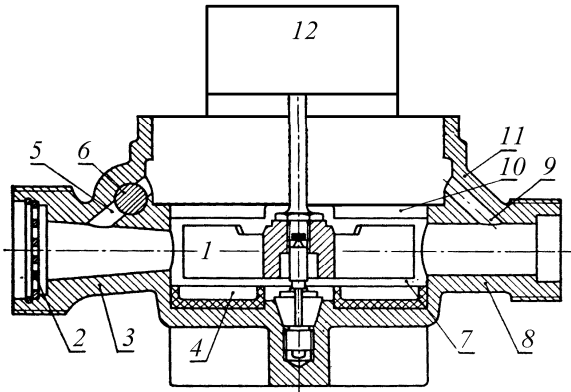

Fig. 4. Outline of mini-turbine rotor system with a vane rotor a vane impeller: 1 – vane rotor; 2 – filter; 3 – inflow spout; 4 – swelling plate; 5 – release channel; 6 – control plug; 7 – rotor chamber; 8 – outflow spout; 9 – release channel; 10 – swelling plate; 11 – gear encasement; 12 – direct current generator

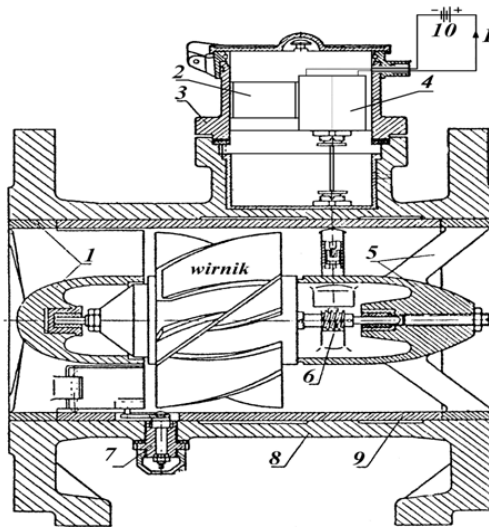

Fig. 5. Outline of mini-turbine rotor system with a propeller in a water pipeline: 1 – stream inflow guide wheel; 2 – generator's fastening; 3 – generator's encasement; 4 – DC generator; 5 – bearing support; 6 – gear; 7 – blade adjuster; 8 – encasement; 9 – sleeve; 10 – battery

As for the third prototype with the generator placed after the turbine, it will serve as an alternative solution using an epicyclic gearing as a torque-increasing element. This will effect in a more compact construction, and under favorable operational conditions will allow for the creation of a device possible to install inside an existing pipeline, for example by means of an adaptor fitting, thus facilitating the installation process and extending the area of application as shown in Fig. 3a.

A construction which assumes placement of all the units of the device on a single element (body) and subsequent installation of the whole in the pipeline flow, attaching it permanently by means of a flange joint or an adaptor fitting, allows for a high flexibility of design. Making use of the entire flow surface ensures both the maximum power obtained from the turbine and the lowest flow loss. However, the application of such a solution is limited to newly-build or renovated pipelines only. As well as that, the installation is laborious and relatively expensive.

Measurable effects. The proposed here research outline is indispensable in determining of optimum selection method of friction pairs possible to apply in construction of mini-generators of electric energy which use transported substance as a working medium. In the discussed case, a lubricant in the friction node is water, that is medium readily available in the device's working environment. The selected compounds, owing to their mechanical properties, are perfectly suited for the purpose, serving additionally as sealing. Further study of durability of the presented prototypes should allow for construction of a device working continuously unattended for a considerable period of time.

Also, it is assumed that the constructed mini-generator will provide sufficient power to charge batteries powering the control and measurement instruments. This device will transform the energy of the medium flowing through a pipeline into electric energy. The essential element of the device is a mini-turbine designed to achieve the maximum efficiency in the broadest possible range of medium flow speed at minimized flow interruptions. Carrying out further research and simulations concerning the influence of geometry and size of turbine's vanes will allow for their rational and effective realization, reducing the costs related to practical execution and analysis of several prototypes with turbines of different geometry.

To sum up, a measurable outcome of the present project, apart from the academic aspect, should be an economical effect resulting from the construction of a power supply system providing electric energy to distributed control and measurement instruments.

References

1. *Karolewski B., Ligocki P.*, Wyznaczanie parametrów małej elektrowni wodnej, Prace Naukowe Instytutu Maszyn, Napędów i Pomiarów Elektrycznych Politechniki Wrocławskiej Nr 56, Wrocław 2004.

2. *Łaski A.*, Elektrownie wodne. Rozwiązania i dobór parametrów, WNT, Warszawa 1971.

3. *Karolewski B. Ligocki P.*, Układy automatyki małej elektrowni wodnej, Pr. Nauk. Inst. Masz. Napęd. i Pom. Elek. PWr. Nr 56, Studia i Materiały nr 24, Wrocław 2004.

4. *Tadeusz J., Sobczyk T.J.*, Małe siłownie cieplne o podwyższonej sprawności, Politechnika Krakowska, Instytut Elektromechanicznych Przemian Energii, Kraków, 23 Marzec 2007.

5. *Sieńko T., Sobczyk T.J.*, Matrix converter control for applications to multiphase high-speed generators, Archive of Electrical Engineering, Vol. 53, No. 2, PWN, Warszawa 2004, s. 217–228.

6. *Flis L., Szturomski B.*, Wstępna ocena wytrzymałości turbiny elektrowni wodnej z wykorzystaniem komputerowego wspomagania projektowania, Zeszyty naukowe Akademii Marynarki Wojennej, rok XLVII nr 3 (166) 2006 s. 6–20.

7. *Kaczyński R, Wilczewska I.*: Investigation of industrial tribological couples using sigma-3 polymer strengthened with carbon fibres. Tribologia. Nr 4. 2006, pp.209–218.

Качинский Р. **Рабочая среда как условие работы для конструирования мимнигенератора электроэнергии** // Проблемы тертя та зношування: Наук.-техн. зб. – К.: Вид-во НАУ «НАУ-друк», 2010. – Вип. 53. – С. 81–91.

Мониторинг системов дистрибуции воды это условие правильного управления эксплуатацию окружающей коммунальной инфраструктуры. Основным проблемом является постройка системы в которой будет передача энергии в любом месте для устройств контрольно-измерительных. Решением выше поставленных задач является транспортное устройство электрической энергии с использованием воды как рабочей среды. В статье предлагается автором постройка гидродинамического мимнигенератора как устройства меняющего кинетическую энергию воды в электрическую энергию.

Рис. 5, табл. 2, список лит.: 7 наим.

Стаття надійшла до редакції 19.05.10