



A. Breshev

# TASKS AND ANALYSIS OF EXPERIMENTAL RESEARCH RESULTS OF NON-CONTACT DRIVE

*Research tasks and goals of experiments of non-contact air-bearing conical drive are determined. Analysis of static experimental behavior of this drive is made. Functional relations between inputs controlled parameters and outputs parameters are analyzed*

**Keywords:** non-contact drive, experimental set-up, gas-film lubrication

## 1. Introduction

Air-bearing non-contact drives are being widely used in machine building. Non-contact drive puts into the rotation movable operating elements, such as a diamond cutter or pumps impellers, compressors, etc., which are held supporting by gas film bearings. Non-contact rotation is made by dividing movable and fixed parts of a drive which are gas-lubricated, and gas-turbine transfer rotating moment to the rotor. The lack of mechanical (between solid bodies) contact between stud and bearing or between thrust journal and thrust bearing allows considerably reduce friction losses, increase rpm range, mean life, bearings parameter stability and vibration resistance also reduce machine cost price and operating costs. Aerostatic bearings of non-contact drive behave as mechanical elements that provide stiffness, damping and inertia force coefficients, that in conjunction with the structural parameters of a shaft, determine the stability and dynamic behavior of entire drive.

## 2. Statement of problem

Non-contact drive that is being considered has several features taking it research and calculation beyond existing techniques. A problem of research is that aerostatic bearings have conical shape which makes them different versus conventional design non-contact drives. New design of considering non-contact drive represents aerostatic angular-contact bearing that makes research investigation more complex. At the same time, this aerostatic system has to provide good dynamic stability, wide range of technical features and good load capacity. In addition, for increasing load capacity and supersonic flow avoidance gas bearings require labyrinth seals

## 3. Main body

### 3.1. Literature review

Mechanical design advantages of bearings without direct contact of components due to gas, liquid or

electromagnetic barriers are considered in work [1]. The use of such bearings in rotating non-contact drives has shown improvements in machine efficiency and technological performance. Design approaches for direct non-contact drives utilizing hybrid single structural elements are demonstrated.

In work [2] the design variants of rotary motion non-contact drive single-support system are analyzed. A design model and determination of bearing capacity, inflexibility and air consumption of single-support system with aerostatic conical angular contact bearing are suggested. Calculation of parameters and comparative analysis of single-support system aerostatic bearing in traditional design is being done and also with up-to-date ring shape cage and labyrinth packing in outcome gas lubricant.

In work [3] engineered mathematical model of load capacity of one-support non-contact drive system are considered. System has aerostatic conical bearings with external pressure boost. Static behavior of non-contact drive is determined.

### 3.2. Research results

Fig. 1 shows 3D model of non-contact air-bearing conical drive with key items.

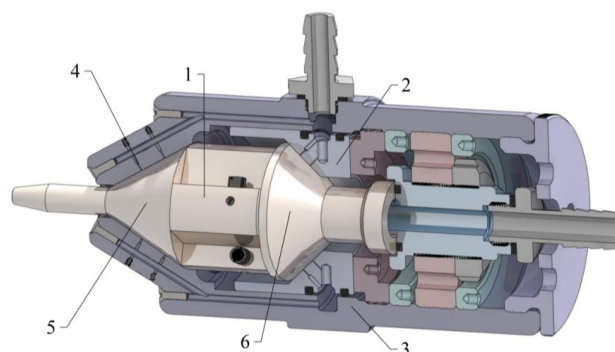

**Fig. 1.** 3D model of non-contact drive.

1 – rotor; 2 – footstep thrust journal bearing; 3 – housing; 4 – orifices of feeding holes; 5 – left thrust journal bearing; 6 – right thrust journal bearing.

Research tasks and goals of experiments:

- checking of mathematical model adequacy (theoretical results and finite element method (FEM) results) of non-contact drive aerostatic gas bearings;
- research of static and dynamic behaviors of non-contact air-bearing conical drive in regime without rotation;
- research of static and dynamic behaviors of non-contact air-bearing conical drive in rotational regime with regulation of inputs data [4];
- development of experimental set-up of non-contact air-bearing conical drive;
- experimental validation of development technology.

Experimental researches that were carrying out on non-contact drive allow making following conclusions:

1. Convergence of experimental and theoretical results of statistic behavior is good. Radial load capacity ( $P_y$ ) imprecision is around 5% – 7%. Axial load capacity ( $P_z$ ) imprecision is 10% at the most. Convergence could be explained by approximate mathematical methods. On the other hand, experiment was complex multifactorial experiment that had precision of measurements. Hence, engineered mathematical model [5] could be implying for engineering calculations of non-contact drive static behavior.

2. Experimentally confirmed that load capacity of non-contact drive enhances with rise of rotor rotating frequency ( $n$ ). Maximal gradient of load capacity accords to 6000 rpm. Further rise of rotation results in constant load capacity, that depends on non-contact drive settings.

3. The comparative analysis of experimental and FEM results have identical relation between rotating moment and rotating frequency. Imprecision is around 7%. Rotating moment of rotor has permanent decreasing tendency with rise of rotating frequency, thus we need enhance pressure support for providing rigid mechanical characteristic [6].

4. Experimental researches shows that non-contact drive static parameters and dynamic characteristics ( $P_y=65$  N,  $P_z=220$  N,  $n= 30000$  rpm) could be widely used in different machines.

## References

1. Pavel Nosko. Developments in technology of non-contact drives for working machines [Text] / Pavel Nosko, Aleksey Breshev, Pavel Fil, Vladimir Breshev // Polish Academy of sciences in Lublin TEKA Commission of motorization in agriculture. Vol. XC. – Lublin, 2010. – P. 209–216.
2. Pavel Nosko. Analysis of design and calculation of parameters of non-contact drive single-support system [Text] / Pavel Nosko, Aleksey Breshev, Pavel Fil, Vladimir Breshev // Polish Academy of sciences in Lublin TEKA Commission of motorization in agriculture. Vol. XIВ. – Lublin, 2011. – P. 102–110.
3. Носко, П.Л. Исследование одноопорной системы бесконтактного привода с аэростатическим подшипником конической формы [Текст] / П.Л. Носко, В.Е. Брешев, А.В. Брешев // Вісник Східноукраїнського національного університету ім. В. Даля. – 2011. – № 5(159). – С. 243–251.
4. Брешев, В.Е. Структурний синтез безконтактних приводів робочих машин [Текст] / Брешев В.Е., Брешев О.В. // Восточно-Европейский журнал передовых технологий. – 2011. – № 5/3 (53). – С. 6 – 10.
5. Брешев, В.Е. Развитие технологии бесконтактных опор и переход к ресурсосберегающей технологии бесконтактного привода [Текст] : Зб. наук. пр. / В.Е. Брешев, А.В. Брешев // Ресурсозберігаючі технології виробництва та обробки тиском матеріалів у машинобудуванні. – Луганськ: Вид-во СНУ ім. В.Даля, 2010. – С. 153 – 159
6. Брешев, А.В. Модернизация конструкции многоопорного бесконтактного привода на аэростатических подшипниках / А.В. Брешев, А.П. Карпов, В.Е. Брешев // Вісник Східноукраїнського національного університету ім. В.Даля. – 2012. – № 6(177). – С. 339 – 344.

## ЗАДАЧИ ТА АНАЛІЗ РЕЗУЛЬТАТІВ ЕКСПЕРИМЕНТАЛЬНИХ ДОСЛІДЖЕНЬ БЕЗКОНТАКТНОГО ПРИВОДУ

**О. В. Брешев**

Визначені цілі та завдання експериментальних досліджень безконтактного привода на конічних аэростатических опорах. Зроблено аналіз отриманих експериментальних статичних характеристик привода, функціональних зв'язків між його вхідними регульованими та вихідними параметрами

**Ключові слова:** бесконтактный привод, експериментальна установка, газове мастило

*Олексій Володимирович Брешев, аспірант кафедри машинознавства Східноукраїнського національного університету ім. В. Даля, тел. (095) 871-82-56, e-mail: abreshev@gmail.com*

## ЗАДАЧИ И АНАЛИЗ РЕЗУЛЬТАТОВ ЭКСПЕРИМЕНТАЛЬНЫХ ИССЛЕДОВАНИЙ БЕЗКОНТАКТНОГО ПРИВОДА

**А. В. Брешев**

Определены цели и задачи экспериментальных исследований бесконтактного привода на конических аэростатических опорах. Сделан анализ полученных экспериментальных статических характеристик привода, функциональных связей между его входными регулируемые и выходными параметрами

**Ключевые слова:** бесконтактный привод, экспериментальная установка, газовая смазка

*Алексей Владимирович Брешев, аспирант кафедры машиноведения Восточноукраинского национального университета им. В. Даля, тел. (095) 871-82-56, e-mail: abreshev@gmail.com*