



**Trotsenko Ye.,
Brzhezitsky V.,
Protsenko O.,
Chumack V.,
Haran Ya.**

EXPERIMENTAL STUDY AND MODELING OF PARTIAL DISCHARGE DETECTION SYSTEM

Об'єктом дослідження є електрична система виявлення часткових розрядів у зразку ізоляції обладнання високої напруги. Для оцінки технічного стану ізоляції електроустановки розроблені й продовжують удосконалюватися різні методи виявлення часткових розрядів. Роль моделювання, віртуального експерименту й віртуальних лабораторних робіт останнім часом зростає у всіх областях технічних наук. Разом з тим, окремі аспекти моделювання електричних систем виявлення часткових розрядів практично розглянуті не достатньо. Моделювання є важливим додатковим видом практичної підготовки до наступної роботи з вимірювальним і випробувальним устаткуванням у професійній діяльності. Метою дослідження є визначення можливості використання в дослідженнях і навчальному процесі в якості аналога системи вимірювання характеристик часткових розрядів еквівалентної схемотехнічної моделі.

Для вимірювання характеристик часткових розрядів у зразках високовольтної ізоляції був зібраний спеціальний експериментальний стенд. Стенд дозволяє проводити випробування фізичної моделі ізоляції прикладанням високої напруги змінного струму. Для візуалізації окремих імпульсів часткових розрядів на осцилографі був розрахований і виготовлений фільтр верхніх частот, який усуває напругу основної частоти 50 Гц, і являє собою фільтр Батерворта 4-го порядку. Проведене осцилографування імпульсів часткових розрядів, які виникають біля поверхні високовольтного електрода в ізоляційному проміжку з електротехнічним картоном. Експериментально встановлено, що в ізоляційному проміжку виникають імпульси часткових розрядів різної амплітуди при явно вираженому ефекті полярності. Експериментальна осцилограма була прийнята як зразок, до якого повинна наблизитися осцилограма при моделюванні. Електрична схема ізоляції представлена традиційною трьох-ємнісною схемою заміщення діелектрика з газовим включенням.

У результаті досліджень встановлено, що при моделюванні можливо одержати результати, близькі до тих, що спостерігаються у фізичному експерименті. Показана можливість моделювання часткових розрядів у діелектрику при наявності двох і більше газових включень.

Ключові слова: схемотехнічне моделювання, частковий розряд, фільтр верхніх частот, фільтр Батерворта.

1. Introduction

Measurement of the partial discharge characteristics is one of the main methods of nondestructive testing and evaluation of high voltage equipment insulation state. Insulation state diagnostics by the method of measuring partial discharges requires the usage of special technical means. Various partial discharge measurement systems are used for measurement of characteristics and location of partial discharge sites in the insulation of high voltage equipment. For visual observation of measurement results, either analog or digital oscilloscopes can be used, or an oscilloscope that is implemented programmatically on an external personal computer (usually a laptop). A USB interface can be used to connect the partial discharge detector to an external personal computer. The issues of partial discharge characteristics measurements are of great importance for the training the students and specialists engaged in the field of electrical equipment insulation diagnostics. At the same time, not all high voltage laboratories have testing equipment for studying the partial discharges. Therefore, the development of a circuit simulation model capable of giving a qualitative picture of the functioning the partial discharge characteristics measurement system is an urgent task.

2. The object of research and its technological audit

The object of research is an electrical system for detecting partial discharges in a sample of high voltage equipment insulation. Partial discharges are of great danger to the insulation of high voltage electrical equipment due to their destructive effects. To evaluate the insulation state of electrical equipment, various methods for detecting partial discharges have been developed and continue to be improved. The role of modeling, virtual experiment and virtual laboratory lessons has recently increased in all areas of engineering. At the same time, some aspects of modeling the electrical systems for partial discharges detection are practically not studied sufficiently. Modeling is an important additional kind of practical training for the further work with measuring and testing equipment in professional activity.

3. The aim and objectives of research

The aim of research is determination of the possibility of using an equivalent circuit simulation model in the research and educational process as an analogue of a system for measuring the characteristics of partial discharges.

To achieve this aim, the following tasks were formulated:

1. Development of an experimental test stand for physical modeling of partial discharges in a sample of high-voltage insulation and analysis of experimental results.
2. Circuit simulation of the partial discharge detection system and determination of the model's ability to replicate qualitatively the results of a physical experiment.

4. Research of existing solutions of the problem

At present, various methods for detecting partial discharges in various types of electrical equipment have been developed. A brief history and comparison analysis of the possibilities that various methods provide are presented in [1]. Due to the high sensitivity of the method and the possibility of comprehensive study of the partial discharge characteristics, an electric method for detecting partial discharges has become widespread [1]. The structure of the electrical circuit for measuring the characteristics of partial discharges can vary depending on the purpose of the measurement and the type of insulation state monitoring. The review [2] shows that practically all modern partial discharge measurement systems use two basic types of partial discharge detection circuits: straight and balanced. For research in this paper, a straight detection circuit has been chosen, that is simpler in implementation. At present, a three-capacitive equivalent circuit is widely used to study partial discharges in a dielectric with a gas cavity under the influence of various waveforms of applied voltage. This circuit appeared as a result of improvements in the scheme from [3]. A critical analysis of this circuit, as well as a short list of changes introduced into the circuit, is presented in [4]. In [5] one of the latest improvements to the circuit is shown (the parallel connection of several three-capacitive equivalent circuits to study partial discharges in a gap with a uniform field). A review of the methods for simulating the equivalent circuit for a dielectric with a gas cavity with partial discharges using the Micro-Cap Evaluation/Student Version [6] is given in [7, 8]. Simulation of one type of the partial discharge measurement system was performed in [9, 10]. In paper [11] the result of simulation of several different partial discharge measurement circuits is shown.

A distinctive feature of this work is that the authors compared the results of complex physical modeling to results of partial discharge circuit simulation.

5. Methods of research

To achieve objectives that were set such research methods were applied: physical modeling, electric method of detecting partial discharges with high voltage application, circuit simulation on a personal computer. The main materials of the research are the results obtained at the experimental test stand for measuring the partial discharge characteristics and its circuit simulation equivalent model.

6. Research results

For research at the Department of High Voltage Engineering and Electrophysics of the National Technical University of Ukraine «Igor Sikorsky Kyiv Polytechnic Institute» an experimental test stand was assembled, the

high-voltage part of it is shown in Fig. 1. As noted above, this scheme corresponds to a straight method for detecting partial discharges. The principle of operation of this scheme has been repeatedly described in various literature [1, 2], and therefore will not be discussed here.



Fig. 1. Photograph of the experimental test stand for measuring the characteristics of partial discharges: 1 – step-up transformer; 2 – coupling capacitor; 3 – test object; 4 – electrical insulation cardboard (an element of the test object); 5 – shield of the high-pass filter; 6 – kilovoltmeter; 7 – cable for connection to an amplifier and an oscilloscope

The test object at physical modeling of partial discharges is an interelectrode gap consisting of two coaxial cylindrical electrodes with electrical insulation cardboard 2.3 mm thick between them. The outer surfaces of the electrical insulation cardboard contain numerous air cavities, shown in Fig. 2. Cylindrical electrodes have different diameters (10 mm and 70 mm, respectively). High voltage is applied to the upper cylindrical electrode of smaller diameter. Partial discharges occur in the area with the greatest electric field intensity – in the air cavities on the cardboard surface near the upper electrode.

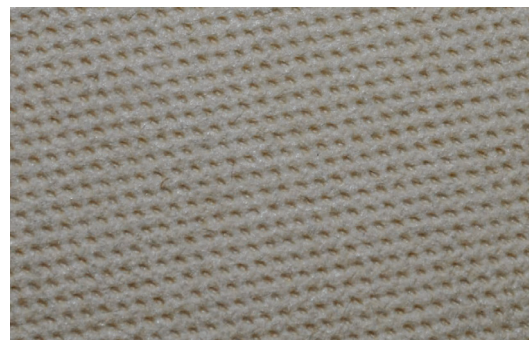

Fig. 2. Cavities on the surface of electrical insulation cardboard (the distance between the cavities in the photograph is 1 mm)

For observation of partial discharge pulses the digital oscilloscope PC-OSCILLOSCOPE, model ISDS220B (manufactured by INSTRUSTAR, China) was used. The oscilloscope was connected to a personal computer via a USB interface.

In accordance with GOST 20074 [12], which corresponds to the International standard IEC 60270 [13], a calibration instrument (oscilloscope) was calibrated for a fully assembled experimental test stand with a connected test object by injecting voltage pulses obtained from a calibration oscillator. As a result of the calibration performed, the value of the scale factor $K_q = 2.57$ pC/V was obtained. Using the scale factor K_q it is possible to

determine the apparent charge q of partial discharges by the formula (GOST 20074):

$$q = K_q \cdot A_q,$$

where A_q – the reading (in volts) of the peak of a partial discharge pulse on the oscilloscope screen.

The obtained value of the scale factor is valid for this complete test arrangement and depends on the values of the parameters of all its elements, as well as the connection schemes (according to GOST 20074).

An example of the obtained oscillogram is shown in Fig. 3. In this case, registered pulses of partial discharges are shown in blue color, and voltage with a frequency of 50 Hz (amplitude value of 3 kV) applied to the insulating gap is shown in red color.

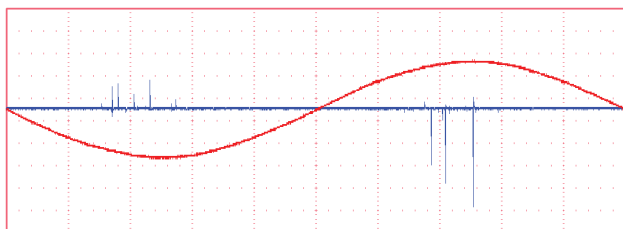

Fig. 3. Oscillogram of partial discharges obtained in a physical experiment at a frequency of 50 Hz

As it can be seen in Fig. 3, partial discharge pulses of different amplitude appear in the insulating gap. In addition, the received oscillogram demonstrates the polarity effect. In particular, in various half-cycles of the applied sinusoidal voltage, the repetition rate of the partial discharge pulses and the amplitude values of the partial discharge pulses are significantly different. The above oscillogram refers to the case when air cavities subjected to electric breakdown are in the area of a high-voltage electrode. The features of partial discharges demonstrated in the physical experiment should be taken into account in the development of a circuit simulation model of a partial discharge measurement system.

The circuit simulation model proposed by the authors is shown in Fig. 4.

In Fig. 4 E_1 – high voltage source of 50 Hz frequency; R_1 – internal resistance of high voltage source. Resistor R_2 represents partial discharge detector. Elements R_3, R_4, L_1, L_2, C_5 and C_6 are a high-pass filter components (Butterworth filter of the 4th order).

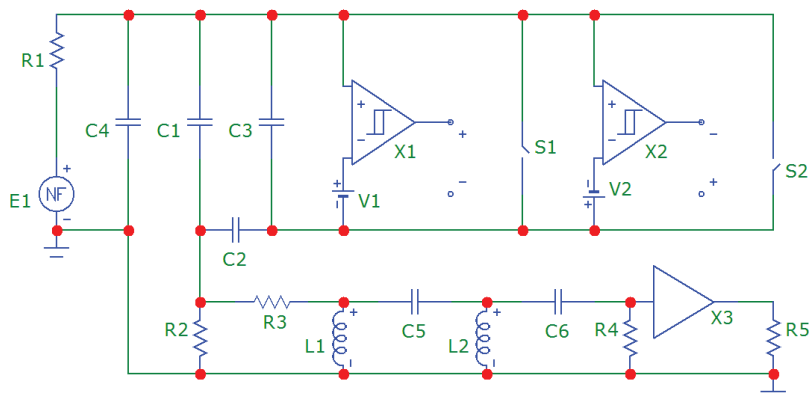

Fig. 4. Circuit simulation of partial discharge detection system

This filter passes high frequencies of the input signal (pulses of partial discharges), while low frequencies of the signal (voltage of 50 Hz frequency) are suppressed. The electric method of detecting partial discharges is sensitive to various kinds of electromagnetic interference, so in order to protect against interference the filter is placed inside the shield (Fig. 1). From the output of the filter, the voltage is applied to the input of the broadband amplifier X_3 , and from its output to the oscilloscope. The input resistance of the digital oscilloscope is represented by a resistor R_5 . Elements $C_2, C_3, V_1, V_2, X_1, X_2, S_1$ and S_2 simulate a defective area (gaseous cavity in solid insulation near the surface of a high-voltage electrode). The purpose of this group of elements is described in detail in [7, 8]. The capacitor $C_1 = 2$ pF represents a capacitance of a dielectric, without a gas cavity section, $C_2 = 2$ pF is a capacitance of the section of the dielectric connected in series with a gas cavity, and $C_3 = 0.05$ pF is a capacitance of a gas cavity. Coupling capacitor has capacitance $C_4 = 48$ pF.

Some difficulty is caused by calculation of the gas cavity capacitance. In the existing approaches to solving this problem, for example, it is assumed that the gas cavity has a spherical shape [14]. In this case, as can be seen from Fig. 2, the shape of the cavity is close to the hemisphere. Therefore, approximately, the cavity capacitance can be determined by the formula for the capacitance of the hemisphere near the plane boundary of two media (when the diametral plane of the hemisphere coincides with boundary of two media) [15]:

$$C_3 = 2 \cdot \pi \cdot a \cdot \epsilon_0 (\epsilon_{r2} + 0.69\epsilon_{r1}), \quad (1)$$

where a – radius of the hemisphere, m; $\epsilon_0 = 8.854 \cdot 10^{-12}$ F/m – electric constant or vacuum permittivity; $\epsilon_{r1} = 1$ – relative permittivity of air; $\epsilon_{r2} = 2.5$ – relative permittivity of electrical insulation cardboard [16]. For $a = 0.25 \cdot 10^{-3}$ m it can be obtained from formula (1) that $C_3 = 0.044$ pF. After rounding, it was finally accepted that $C_3 = 0.05$ pF.

The capacitance of the section of the dielectric connected in series with the gas cavity is also determined approximately. Since the depth of the air cavities (Fig. 2) is much smaller than the thickness of the electrical insulation cardboard, and also taking into account the fact that the pores are not inside but on the surface of the cardboard, it was assumed above that $C_2 \approx C_1 = 2$ pF.

The simulation was performed at the following values of the remaining parameters: $R_1 = 1 \Omega$; $R_2 = R_3 = R_4 = 500 \Omega$; $R_5 = 1 \text{ M}\Omega$; $C_5 = 172$ pF; $C_6 = 415$ pF; $L_1 = 104$ mH; $L_2 = 43$ mH.

The resistance of the switches S_1 and S_2 in the open state is equal to $1 \cdot 10^{20} \Omega$, and in the closed state it is equal to 100Ω . The parameters of the elements V_1, V_2 , and X_1, X_2 , set the values of the partial discharge inception and extinction voltage for different polarities of the applied voltage [7, 8].

In this paper, the partial discharge inception voltage of gas cavity is assumed equal to +2.81 kV for the positive half-cycle and –2.81 kV for the negative half-cycle of sinusoidal voltage. The partial discharge extinction voltage was assumed to be +2.67 kV for the positive half-cycle and –2.75 kV for the negative half-cycle. Fig. 5 shows that when choosing these

parameter values for simulation, it is possible to achieve results qualitatively close to those observed in the physical experiment (Fig. 3). In Fig. 5, the red curve corresponds to the high voltage that is applied to the test object. The blue curve corresponds to the voltage that appears at the input of the oscilloscope. Fig. 6, 7 separately show the voltage waveforms that occur directly on the air cavity, during the negative and positive half-cycles respectively.

In the above simulation example, only one gas cavity was used. In a physical experiment, the surface of the upper electrode covers several gas cavities. Accordingly, under the

influence of high voltage, partial discharges can occur in different gas cavities. An increase in the number of gas cavities in the model and also taking into account the statistical dispersion of the partial discharge characteristics will contribute to reducing the difference between the results of virtual and physical experiment. For the test object considered in this paper, several three-capacitive equivalent circuits of a dielectric with a gas cavity can be connected in parallel, as shown in Fig. 8.

Determining the parameters of such model requires further research.

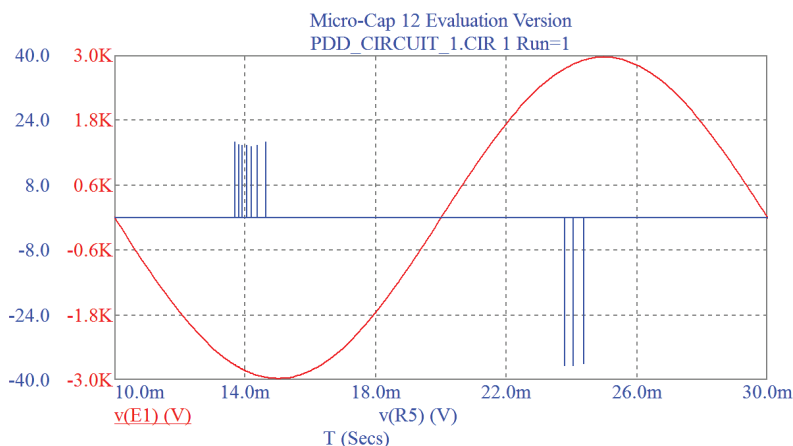

Fig. 5. Partial discharges obtained in a virtual experiment at a 50 Hz frequency

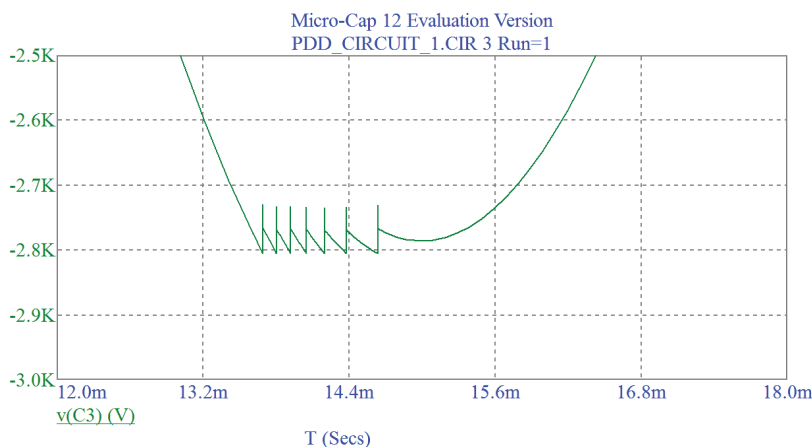

Fig. 6. The voltage on the gas cavity during the negative half-cycle of the applied voltage

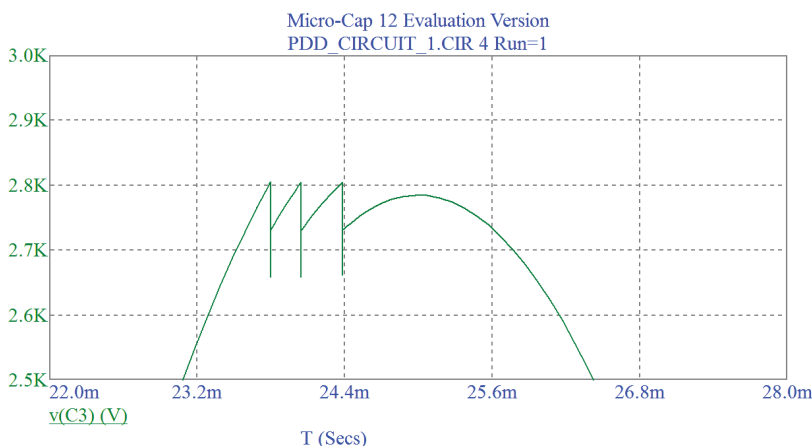

Fig. 7. The voltage on the gas cavity during the positive half-cycle of the applied voltage

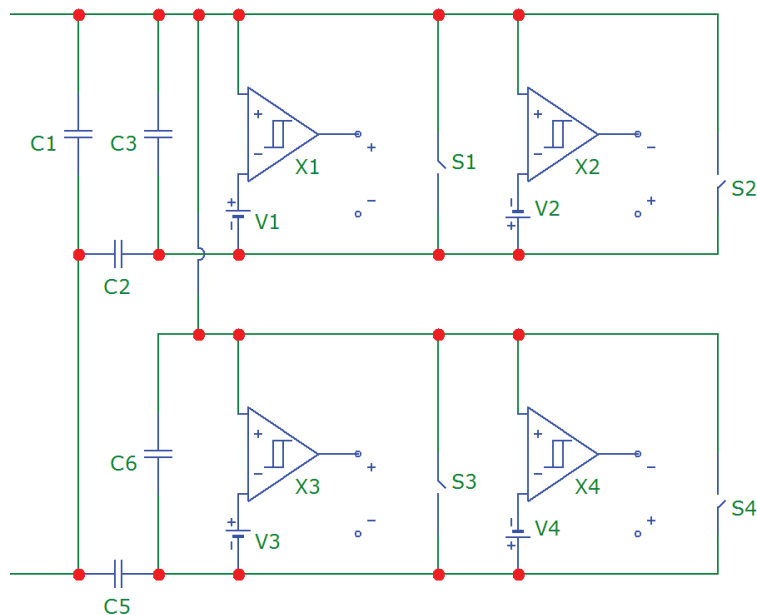

Fig. 8. An example of a dielectric model with two gas cavities

7. SWOT-analysis of research results

Strengths. The strengths of this research are:

- in contrast to other studies, in addition to circuit simulation, physical modeling of partial discharges in the insulating gap was performed;
- a physical experiment made it possible to determine that features of the partial discharge process that should be replicated by the circuit simulation model;
- a potential possibility of using an equivalent circuit simulation model in the research and educational process instead of a physical system for measuring the characteristics of partial discharges is confirmed.

Weaknesses. The weak sides of this research are for the purpose of circuit simulation, a demo version of the software was used, that does not allow studying large complicated electrical circuits.

To minimize the differences between the results of a virtual and a physical experiment, professional version of software is required.

Opportunities. The additional opportunities that this research provides include:

- obtained results indirectly confirm the wide possibilities that can be provided by the improvement of traditional three-capacitance circuit of a dielectric with a gas cavity with partial discharges;
- continuation of research on the development and modification of virtual and demonstration laboratory lessons in the field of electric power engineering.

Threats. A separate difficult task is determination of the dimensions of gas cavities, their location in a solid dielectric, and also the values of partial discharge inception and extinction voltage for these cavities. There are attempts to solve this problem.

For example, it is assumed that the gas cavity has a spherical shape [14]. However, defects in real insulation are much more difficult.

Therefore, the simulation of partial discharges can be characterized as an approximate one.

8. Conclusions

1. To measure the characteristics of partial discharges in samples of high-voltage insulation, a special experimental test stand was assembled. The stand allows testing the physical model of insulation by applying alternating current high voltage. To visualize individual partial discharge pulses on an oscilloscope, a high-pass filter was designed and assembled that suppresses the 50 Hz main frequency voltage, and is a 4th order Butterworth filter. The oscillogram of partial discharge pulses that occur near a surface of high-voltage electrode in an insulating gap containing an electrical insulation cardboard was obtained. It has been experimentally established that partial discharge impulses of different amplitudes arise in the insulating gap with an explicit polarity effect. The experimental oscillogram was adopted as a sample, to which the oscillogram should approach in the simulation.

2. Circuit simulation of the assembled partial discharge detection system was performed. An approximate equivalent circuit was used to simulate behavior of an insulation sample at partial discharges.

Initially, it was assumed that there is only one gas cavity with partial discharges in the insulation. The electrical equivalent circuit for insulation was represented by a traditional three-capacitive equivalent circuit for a dielectric with a gas cavity. As a result of the research it was established that it is possible to obtain results close to those observed in the physical experiment. The possibility of modeling partial discharges in a dielectric in the presence of two or more gas cavities is shown. The possibility of an accessible realization of a physical and virtual system for studying such complex phenomenon as partial discharges in a solid dielectric was demonstrated.

References

1. Vdoviko V. P. Chastichnye razriady v diagnostirovanii vysokovol'nogo oborudovaniia. Novosibirsk: Nauka, 2007. 155 p.

2. Gulski E. Digital analysis of partial discharges // IEEE Transactions on Dielectrics and Electrical Insulation. 1995. Vol. 2, Issue 5. P. 822–837. doi: <http://doi.org/10.1109/94.469977>
3. Gemant A., Philippoff W. Die Funkenstrecke mit Vorkondensator // Zeitschrift für Technische Physik. 1932. Vol. 13, Issue 9. P. 425–430.
4. Lemke E. A critical review of partial-discharge models // IEEE Electrical Insulation Magazine. 2012. Vol. 28, Issue 6. P. 11–16. doi: <http://doi.org/10.1109/mei.2012.6340519>
5. Partial discharge characteristics of uniform gap in oil-impregnated paper insulation under switching impulse voltage / Deng J. et. al. // IEEE Transactions on Dielectrics and Electrical Insulation. 2016. Vol. 23, Issue 6. P. 3584–3592. doi: <http://doi.org/10.1109/tdei.2016.005508>
6. Micro-Cap 11. Electronic Circuit Analysis Program. Reference Manual. Sunnyvale: Spectrum Software, 2014. 1040 p. URL: <http://www.spectrum-soft.com/down/rm11.pdf>
7. Simulation of partial discharges under influence of impulse voltage / Trotsenko Y. et. al. // Technology Audit and Production Reserves. 2017. Vol. 1, Issue 1 (39). P. 36–41. doi: <http://doi.org/10.15587/2312-8372.2018.123309>
8. Effect of voltage harmonics on pulse repetition rate of partial discharges / Trotsenko Y. et. al. // Technology Audit and Production Reserves. 2017. Vol. 2, Issue 1 (40). P. 37–44. doi: <http://doi.org/10.15587/2312-8372.2018.126626>
9. A Matlab Simulink model for a partial discharge measuring system / Gunawardana S. D. M. S. et al. // Electrical Engineering Conference. 2015. P. 29–34.
10. Pahomov A. I. Metody i sredstva diagnostiki izoliatsii asinhronnykh dvigatelei sel'skohoziastvennogo proizvodstva na osnove chastichnykh razriadov: Abstract of Doctor of Technical Sciences Thesis. Krasnodar, 2005. 32 p.
11. Development of partial discharge model, simulation and measurement / Kolev N. P. et. al. // 1999 Conference on Electrical Insulation and Dielectric Phenomena. Austin, 1999. P. 214–217. doi: <http://doi.org/10.1109/ceidp.1999.804629>
12. GOST 20074-83. Elektrooborudovaniye i elektroustanovki. Metod izmereniya kharakteristik chastichnykh razriadov. Moscow: Izdatel'stvo standartov, 1983. 22 p.
13. IEC 60270:2000. High-voltage test techniques – Partial discharge measurements. Geneva: IEC Central Office, 2000. 99 p.
14. Illias H. A., Chen G., Lewin P. L. Modelling of Partial Discharge Activity in Different Spherical Cavity Sizes and Locations within a Dielectric Insulation Material // Proceedings of the 9th International Conference on Properties and Applications of Dielectric Materials. Harbin, 2009. P. 485–488. doi: <http://doi.org/10.1109/icpadm.2009.5252384>
15. Iossel' Yu. Ya., Kochanov E. S., Strunskiy M. G. Raschet elektricheskoy emkosti. Leningrad: Energoizdat, 1981. 288 p.
16. Makarov E. F. Spravochnik po elektricheskim setyam 0.4–35 kV. Vol. 1. / ed. by Goryunov I. T., Lyubimova A. A. Moscow: Papirus Pro, 1999. 608 p.

Trotsenko Yeogeniy, PhD, Associate Professor, Department of High Voltage Engineering and Electrophysics, National Technical University of Ukraine «Igor Sikorsky Kyiv Polytechnic Institute», Ukraine, e-mail: y.trotsenko@kpi.ua, ORCID: <http://orcid.org/0000-0001-9379-0061>

Brzhezitsky Volodymyr, Doctor of Technical Sciences, Professor, Department of High Voltage Engineering and Electrophysics, National Technical University of Ukraine «Igor Sikorsky Kyiv Polytechnic Institute», Ukraine, e-mail: v.brzhezitsky@kpi.ua, ORCID: <http://orcid.org/0000-0002-9768-7544>

Protsenko Olexandr, PhD, Associate Professor, Department of High Voltage Engineering and Electrophysics, National Technical University of Ukraine «Igor Sikorsky Kyiv Polytechnic Institute», Ukraine, e-mail: apro54@ukr.net, ORCID: <http://orcid.org/0000-0002-7719-3336>

Chumack Vadim, PhD, Associate Professor, Department of Electromechanics, National Technical University of Ukraine «Igor Sikorsky Kyiv Polytechnic Institute», Ukraine, e-mail: chumack_kpi@ukr.net, ORCID: <http://orcid.org/0000-0001-8401-7931>

Haran Yaroslav, Assistant, Department of High Voltage Engineering and Electrophysics, National Technical University of Ukraine «Igor Sikorsky Kyiv Polytechnic Institute», Ukraine, e-mail: y.garan@kpi.ua, ORCID: <http://orcid.org/0000-0003-3242-9218>