

## Technological foundations of processing tomato pomace in feed additives

**Bogdan Yegorov, Ilona Malaki**

*Odessa national academy of food technologies, Ukraine*

---

### Keywords:

Waste  
Tomatoes  
Processing  
Extrusion  
Additive

---

### Article history:

Received 03.01.2014  
Received in revised  
form  
06.04.2014  
Accepted 16.04.2014

---

### Corresponding author:

Ilona Malaki  
E-mail:  
ryaguzova.ilona@mail.ru

---

### Abstract

**Introduction.** Search for new types of alternative raw material for the efficient development of poultry industry and problem of waste disposal of canning industry made it necessary to develop a method of processing tomato pomace in feed additives.

**Materials and methods.** Sampling, preparation and testing were carried out by general and specific organoleptic and physical-technological methods of assessment and analysis of the properties of raw materials and finished products.

**Results.** Incorporation of tomato pomace in the feed additive reduces the cost of raw materials and expenses associated with moistening of the mixture before extrusion and incorporation of chalk feed will solve the problem of calcium imbalance of laying hens. It was found that extrusion process has improved the physical properties of feed additive and showed the possibility of its use as a feed component: moisture content decreased by 34.5 %, the angle of repose increased by 11.4 %, flowability decreased by 39.7 % and bulk density decreased by 32.3 %.

**Conclusions.** The resulting feed additive will solve the problem of diversification of raw materials, waste, calcium imbalance of laying hens and reduce expenses on compound animal feedstuff production.

---

### Introduction

At present stage of reform and development of the food complex of Eastern Europe countries there is a strategic issue to increase production of high-quality food for their own needs, while gaining international food market. One of the areas capable in the short term to solve the assigned problems is poultry breeding [2].

Poultry breeding is the most powerful branch of world agriculture which differs in extremely high dynamic development; is unbeatable on cost of feed and labor costs per production unit and provides the population with high-quality food [1-3].

However, despite the dynamic development poultry farming is facing a number of problems solution of which will enable industry to take new heights.

A necessary condition for the industry development is search for new types of non-traditional materials that can reduce the content of cereals in the poultry feeding and able to reduce the cost of compound animal feedstuff products.

At the same time, according to the data of the State Statistics Committee of Ukraine in recent years the production of fresh tomatoes in our country significantly increased. In 2000 Ukraine cultivated 1126.6 thousand of tons of tomatoes and in 2012 this number has already reached 2274.1 thousand of tons. Along with fresh vegetables production also production volume of tomato canning products and waste received in the process of their production has been increased [13, 14].

Therefore, canning industry faces the problem of herbal waste disposal of high humidity in the form of tomato pomace which contain a number of nutrient bioactive substances and can serve as an effective component of compound animal feedstuff production in nutrition diet of farm animals and poultry. However, insufficient attention is so far paid to the use of canning industry waste in our country. At most companies these valuable feed stuff are spoiled and destroyed in large quantities creating a significant threat to the environment [5, 6].

Limiting factor for use of tomato pomace in the process of compound animal feedstuff production is high humidity which is an excellent environment for the development of pathogenic organisms and significantly reduces the shelf life of waste. They are highly perishable and require immediate disposal. Existing disadvantages considerably complicate the processing and use of by-products of the canning industry in the compound animal feedstuff production of high humidity [6].

Literature data analysis shows various ways of processing tomato pomace both independently and in mixtures with other by-products of the canning industry. Tomato pomace can be fed to animals and poultry as green feed, silage and subjected to drying and granulation.

The most rational way of processing tomato pomace is drying to a final moisture content 8...14 % and use at the process of compound animal feedstuff production as feed flour [7]. However, this method was not widespread in the feedstuff industry due to high price – high electric power consumption makes it expensive.

Therefore, the most rational way to use them is the processing in feed additives for further use in the manufacture of compound poultry feedstuff.

Along with the problem of expanding the raw material base big problem for the poultry industry is the calcium imbalance including calcium deficiency of laying hens during ovulation period. This necessitates the development of feed additives that will expand the raw material base, solve the problem of the imbalance of calcium of poultry and reduce the production costs of compound animal feedstuff production.

## **Materials and methods**

In the manufacture of feed additive fodder chalk and tomato pomace were used as raw material. Extrusion of additive has been carried out with grain extruder E3-150 (Fig. 1) at a temperature of 110...120°C and a pressure of 2...3 MPa.

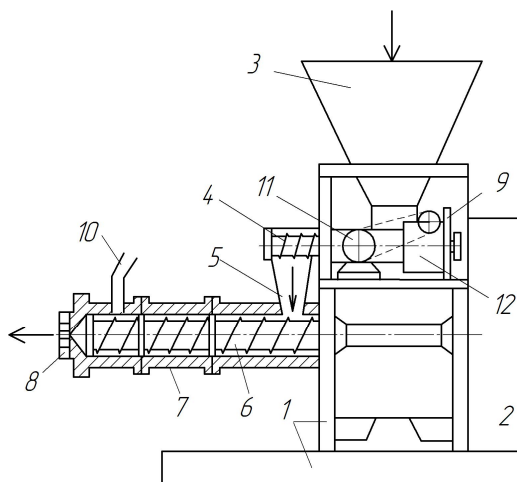

**Fig. 1. Extruder E3-150 (Bronto, CherkasyElevatorMash)**

1 – base (frame), 2 – main drive, 3 – bin, 4 – feed screw dispenser, 5 – receiving chamber, 6 – forcing screw, 7 – prefabricated housing, 8 – matrix, 9 – secondary drive, 10 – thermometer, 11 – DC motor, 12 – reducer.

Feed additives has been assessed by physical parameters such as moisture content, bulk density, modulus size, flowability, angle of repose, index of extrudate expansion.

Moisture content was determined by drying the sample of the product in the weighting cup in the drying oven at a temperature of 130°C for 40 min. and was calculated using the formula:

$$W = (q_1 - q_2) / (q_1 - q_0) \cdot 100, \%$$

where  $q_0$  – mass of empty weighting cup, g;  $q_1$  – mass of weighting cup with a lifting bar before drying, g;  $q_2$  – mass of weighting cup with a lifting bar after drying, g.

Extrudate expansion ratio was determined by extrudate diameter to the diameter of the outlet of the extruder matrixes.

Bulk weight of additive has been determined with a half-liter grain-unit scale which consists of jack, filler, cylinder head, bailer, knife, puller and measurer. The cylinder was closed with funnel, put down on filler with bailer and after the product was poured in filler, the cylinder with bailer has been removed. The knife was removed faster from the crack and after the puller and the product fell in the measurer the knife was again gently inserted into the slot. Then the measurer with the filler has been removed from the jack, overthrown, holding the knife and the filler, and poured the excess remaining on the knife. Then the knife has been removed from the crack, the measurer with the product has been weighed and the nature of the product was set up accurate within  $\pm 0.5$  g.

Angle of natural repose was determined by the product pouring from the filler on a horizontal surface. The product has been poured through a metal funnel that has a cone angle of 60°, until the top reached the height of vertical walls of the device. There has been performed protractor angle measurement. For this the protractor has been applied to the cone generatrix and determined by screeching angle  $\beta$ . Then the angle of natural repose  $\alpha$  was considered as:  $\alpha = 90 - \beta$ .

Flowability has been determined by the method of pouring the product through hole of a certain size (diameter 4 cm). The product was poured in a box with the outlet which was closed with the latch. To determine the product flowability the latch has been open and the time of pouring of the product through the outlet on a horizontal surface has been noted.

Volume of poured product was measured with the cylinder. Flowability was determined by the formula:

$$V_c = q / (S \cdot t), \text{ cm}^3/\text{sec.},$$

where  $q$  – volume of product that passed through the hopper outlet,  $\text{cm}^3$ ;  $t$  – duration of pouring of the product, sec.;  $S$  – cross-section area of the outlet,  $\text{cm}^2$ .

Determining the size of the module was performed on a laboratory plansifter. Sample of the product on the top sieve placed laboratory plansifter, closed the lid and sieved for 5 minutes at 190...210 sieve oscillations per minute. After sifting weighed stairs on each sieve.

The size modulus was determined by the formula:

Size modulus determination has been carried out with the help of the laboratory diffuser. Sample of the product was placed on the top sieve of the laboratory diffuser, then it was closed with the lid and sieved for 5 minutes at 190...210 sieve oscillations per minute. After sifting remaining residue on each sieve were weighed.

$$M = (3,5 \cdot m_1 + 2,5 \cdot m_2 + 1,5 \cdot m_3 + 0,78 \cdot m_4 + 0,28 \cdot m_5) / 100, \text{ mm},$$

where  $m_1, m_2, m_3, m_4$  – mass of remaining residue from the sieves with holes  $\emptyset 3, \emptyset 2, \emptyset 1, \emptyset 0,56$  mm, g;

$m_5$  – mass of passage with holes  $\emptyset 0,56$  mm, g;

3,5; 2,5; 1,5; 0,78 – the average size of the particles remaining on sieves with holes  $\emptyset 3, \emptyset 1, \emptyset 0,56$  mm, accordingly, mm;

0,28 – the average size of the particles which passed through a sieve with holes  $\emptyset 0,56$  mm;

100 – mass of the sample taken for the analysis, g.

All tests were performed at 3-fold review of measurements and experimental results have been processed by software (Mathsoft, Inc., USA; Mathcad Professional).

## Results and discussion

The feasibility of processing tomato pomace in feed additives demonstrates their physical properties. Therefore, at the first phase of work there has been investigated physical properties of tomato pomace indicators such as moisture content, bulk weight and density. Thus, weight ratio of moisty tomato pomace was 70 %, bulk weight comprised  $399 \text{ kg/m}^3$  and accordingly density was  $1.29 \text{ kg/m}^3$ .

Analysis of studies of the physical properties of tomato pomace suggests that these residues are characterized by poor physical properties because of their high moisture content. Therefore, it is advisable to carry out their processing only as part of other grain ingredients of compound animal feedstuff for physical properties of the mixture to get satisfactory value and avoid demixing and clumping of products. In addition, high humidity of pomace may lead to corrosion of metal equipment.

A necessary condition for the development of feed additives using tomato pomace is the choice of the optimal additive components in terms of chemical composition, physical properties and cost. It is necessary to consider not only the cost of raw materials but also

the cost of electricity for its processing. Therefore, a further step in our research was the analysis of physical-chemical properties of grain components, costs related to their acquisition and processing.

Among cereals the most widespread in the poultry is corn as an energy source that exceeds all grain cereal feed that is 1,382 mJ of metabolizable energy but it has less protein (8...10 %). Corn contains 4...6 % of fat, about 60...70 % of starch and 2...3 % of fiber. In addition, the yellow pigment of corn make attractive broiler carcass and add to the egg yolks really yellow color [8-11]. In addition, the specific power consumption for extruding corn is lower by 10.2 % than wheat by 14.3 % lower compared to shelled oats and by 24.4 % compared with peeled barley [12].

The inclusion of the mineral feed additive will solve the problem of calcium deficiency of laying hens.

Fodder chalk is characterized by low cost and high contents of calcium what has made it widespread among other minerals. And due to its physical properties, chalk by sorbing moisture can increase the percentage of making tomato pomace, thereby reducing the cost of raw materials that is an important factor in calculating recipes of compound poultry feedstuff [4].

To determine the most optimal feed additive composition there has been determined moisture content of the components that can be included into its contents. Moisture content of corn comprised 12.9 %, fodder chalk – 0.5 %, tomato pomace – 70.0 %.

Extrusion process allows to save a number of nutrients and biologically active substances, to improve the taste and aromatic properties, increase the assimilation of food and increase shelf life of products [15-17].

Considering useful properties (advantages) of extruded products we have developed a way of processing tomato pomace in feed additives. As humidifier mixture before extrusion we were using tomato pomace. Since in the process of the extrusion up to 50% of moisture from the extrudate has been evaporated, we calculated the amount of tomato pomace which provided moisture content after extrusion in feed additive of not more than 12.5 % due to the inability to keep extrudate with higher moisture content for a long time. So dry mixture before extrusion shall be not more than 16...18 %.

Therefore, the estimated water content of the mixture before extrusion with the introduction of 73 % corn with a moisture content of 12.9 %, 12 % tomato pomace with a moisture content of 70 % and 15 % fodder chalk with a moisture content of 0.5 % comprises 17.89 %. If adding more tomato pomace of the mixture increases its moisture content and extrusion process fails completely while a smaller quantity the mixture have to be further moisten with water resulting in additional costs.

Addition of fewer quantity of fodder chalk is inefficient because it does not meet the needs of animals and poultry in calcium in full as well as increase of its addition negatively affects the physical and technological properties of the feed additive. Therefore, the introduction of such a large number of components of the additive is the best in terms of physical and technical characteristics and costs of their processing (table 1).

**Table 1**

**Feed additive contents**

Components content in feed additive, %	Raw material			Total
	Corn	Fodder chalk	Tomato pomace	
	73	15	12	100

Figure 2 demonstrates traditional and developed processing technology of tomato pomace. Traditional technology involves the processing of tomato pomace in feed flour by grinding it, drying, cooling, grinding and packaging. Processing of tomato pomace by traditional technology requires the use of external heat sources which requires additional investment in boiler construction, expenses on gas, liquid or solid fuel. At the same time as the extrusion process eliminates these costs, thereby reducing expenses on processing of tomato pomace in feed additives. Furthermore, in the process the structural and mechanical and chemical state of the mixture are changed and as result satisfactory sanitary conditions and better assimilation of nutrients are received.

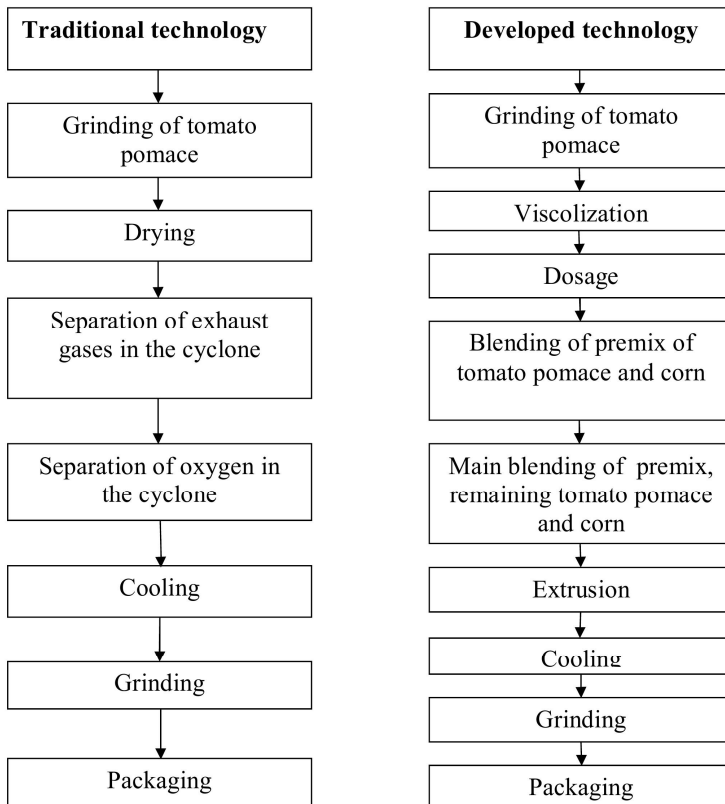

**Fig. 2. Technological methods of processing tomato pomace**

The developed technology provides cleaning of corn from impurities, grinding on hammer mill to a particle size of 3 mm and dosage. Separately there are prepared tomato pomace for processing including grinding with grinder to particle size of 2...3 mm, viscolize and dosage. Fodder chalk with humidity less than 10 % has been cleaned of impurities and dosaged. Then there is prepared premix for which tomato pomace and corn taken in proportion of 1:1 are mixed in grinder for 180 sec. to form a homogeneous mixture. Then the main blending of the premix with the remaining of corn and fodder chalk in blade-type mixer for 120...180 sec. The resulting mixture is extruded at a temperature of 110...120°C and pressure of 2...3 MPa. The resulting extrudate of moisture 11.6 % has been

cooled to a temperature that does not exceed the ambient temperature by more than 10°C, grind in a grinder to a particle size of 3 mm for storage, if necessary, extrudate is packaged.

Samples of feed additives were studied using indicators that mostly characterize the technological properties of the finished products such as angle of natural repose, flowability, bulk density, and efficiency of extrusion has been defined by specific power consumption, extrudate expansion index, starch dextrinizing degree and moisture content (table 2).

**Table 2**  
**Extrusion effect on the physical properties of the feed additive (n = 3, P≥0,95)**

Index	Feed additive		
	Before processing	After processing	Alterations, %
Moisture content, %	17,7	11,6	-34,5
Angle of natural repose, <i>degrees</i>	35,0	39,0	+11,4
Bulk density, <i>kg/m<sup>3</sup></i>	665,0	450,0	-32,3
Flowability, <i>cm/sec</i>	13,6	8,2	-39,7
Size modulus, <i>mm</i>	1,8	1,2	-33,3
Starch dextrinizing degree, %	56,2		
Extrudate expansion index	2,1		
Specific power consumption, <i>kW·h/t</i>	16,0		

Analysis of the data presented in table 2 demonstrates that during feed additive extrusion moisture content is reduced by 34.5 %, the angle of natural repose is increased by 11.4 %, flowability is reduced by 39.7 %, bulk density is decreased by 32.3 %.

When extruding feed additive starch dextrinizing degree is 56.2 % while the recommended value is not less than 55 %, the specific power consumption is 16 kW·h/t and extrudate expansion index is 2.1. The low degree of starch dextrinizing degree and extrudate expansion index is explained by the formation during extrusion of protein-carbohydrate complexes.

## Conclusions

1. Addition to the feed additive 12 % of tomato pomace reduces the cost of raw materials and expenses associated with moistening the mixture before extrusion.
2. Use of chalk feed in additives of a bound state will provide the organism of the poultry with calcium according to physiological needs.
3. Extrusion process has improved the physical properties of the feed additive including moisture content decreased by 34.5 %, the angle of natural repose increased by 11.4 %, flowability decreased by 39.7 % and the bulk density decreased by 32.3 %. Also as a result of extrusion there has increased nutrient uptake as that is demonstrated by starch dextrinizing degree (56.2 %).
4. Obtained feed additive allows to expand the raw material base in compound animal feedstuff production, recycle byproducts of canning industry of high humidity, solve the problem of calcium deficiency of poultry and reduce expenses on compound animal feedstuff production.

## References

1. James A.A., Sullivan N.O. (2006), Breeding chickens to meet egg quality needs, *International Hatchery Practice*, 19(7), pp. 7–9.
2. Al-Khalifa H., Ragheb G. (2013), Enhancing diversity of poultry products by producing high quality brown eggs, *European Scientific Journal*, 9(24), pp. 230–240.
3. Esmail S.H.M. (2003), How nutrition affects egg quality, *Poultry international*, 42(3), pp. 32–34.
4. Yegorov B.V., Malaki I.S. (2013), Analiz effektivnosti ispolzovaniya razlichnykh kaltsiyisoderyzhashchikh mineralnykh kormovykh dobavok v kormlenii sel'skokhozyaistvenoy ptitsy, *Naukovi pratsi ONAKHT*, 44(1), pp. 38–40.
5. Mlodowski M., Kuchta M. (1998), Using carotenoid pigments from tomato pulp to improve egg yolk colour in laying hens, *Roczniki Naukowe Zootechniki*, 25, pp.133–144.
6. Mansoori B., Modirsanei M., Kiaei M.M. Influence of dried tomato pomace as an alternative to wheat bran in maize or wheat based diets, on the performance of laying hens and traits of produced eggs, *Iranian Journal of Veterinary Research*, 9(4), pp. 341–346.
7. Korobko V.N. (2002), Otkhody plodoovoshchnogo proizvodstva – rezerv ukrepleniya kormovoy bazy jyvotnovodstva, *Khraneniye i pererabotka zerna*, 1, pp. 53–55.
8. Panin I. (2006), Kukuruza kak komponent kombikorma, *Kombikorma*, 6, pp. 67–68.
9. Kokić B., Lević J., Chrenková M., Formelová Z., Poláčiková M., Rajský M., Jovanović R. (2013), Influence of thermal treatments on starch gelatinization and in vitro organic matter digestibility of corn, *Food & Feed Research*, 40(2), pp. 93–99.
10. Tica N.Lj, Okanović Đ.G., Zekić V.N., Filipović S.S. (2009), The effect of extruded corn on the economic results of broilers production, *Food & Feed Research*, 36(3–4), pp. 59–64.
11. Pelevin A.D., Pelevina G.A., Ventsova I.Yu. (2008), *Kombikorma i ikh komponenty*, Moscow.
12. Yegorov B.V., Vorona N.V. (2011), Tekhnolohiya vyrobnytstva ekstrudovanoi dobavky dlya sil'skohospodarskoyi ptitsi, *Zernovi produkty i kombikormy*, 4(44), – pp. 31–36.
13. (2013) *The State Statistics Service of Ukraine, Crop Raising in Ukraine 2012*, Statistical Book, Kyiv.
14. <http://faostat.fao.org/site/339/default.aspx>
15. Riaz M.N. (2007), *Extruders and expanders in pet food, aquatic and livestock feeds*, Agrimedia GmbH, Clenze.
16. Mian N.R. (2000), Future extrusion: advances in construction, control systems and internet compability, *Petfood Industry*, 42(12), pp. 4–10.
17. Komnik G. (2000), Ekstrudirovanie - vernuy put k povysheniyu kachestva, *Kombikorma*, 7, pp. 19–21.