

V.G. LITOVCHENKO

V.E. Lashkaryov Institute of Semiconductor Physics, Nat. Acad. of Sci. of Ukraine
(41, Prosp. Nauky, Kyiv 03028, Ukraine; e-mail: lv@isp.kiev.ua)**ON SOME IMPORTANT RESULTS
IN SEMICONDUCTOR SURFACE SCIENCE OBTAINED
IN UKRAINE DURING THE INDEPENDENCE
YEARS (1991–2016)**

УДК 539

Some important results obtained by Ukrainian physicists in semiconductor surface science during the independence years (1991–2016) are discussed. The review is mainly focused on the results obtained for nano-dimensional and quantum-size structures and classifies them according to the main scientific directions in the modern Ukrainian semiconductor surface science.

Ключові слова: semiconductor surface science, physics of real semiconductor surface, physics of metal–semiconductor interface, physics of atomically clean surface, physics of surface-sensitive semiconductor sensors.

1. Introduction

Semiconductor surface science is an important branch of solid state physics, along with the physics of bulk phenomena and other specialized sections. It has a high rank in modern electronics.

Researches of semiconductor surface have been started in Ukraine since the 1930s at the laboratories of the Institute of Physics of the Academy of Sciences of Ukraine and at the Chairs of physics at the Kyiv and Odesa Universities. The research groups were headed by Oleksandr Henrikhovich Goldman, Vasil Ivanovych Lyashenko (at that time, the first dean of the Faculty of physics and mathematics at the Kyiv University), and Elpidifor Anempodystovych Kirillov. Some later, the groups were joined by a skilled scientist Vadym Evgenovych Lashkaryov, who, the first in the world, discovered the $p - n$ junction in 1941.

The surface researches were aimed at studying the electronic and ionic phenomena occurring at metal–semiconductor interfaces in the structures containing oxide (CuO_x , FeO_x) and photosensitive (Ag_2S_3) semiconductors. At that time, those semiconductors were widely applied in non-vacuum power rectifiers. An important new result was the discovery of space charge regions of two types near the surface: depleted or enriched by free charge carriers. The

properties of those regions changed under the action of the external electric field, which provided the current rectification effect through this metal–semiconductor structure. This key result was immediately (in 1938) published by V.I. Lyashenko and G.A. Fedorus in such leading Soviet scientific journals as *Bulletin of the Academy of Sciences of the USSR* and *Journal of Experimental and Theoretical Physics*. Works about the discovery of $p - n$ junction were published in the same journals in 1941.

After the World War II, semiconductor surface science was actively developed further, both at the Chairs of the Kyiv, Lviv, Odesa, and other Universities, and at the institutions of the Academy of Sciences (the Institute of Semiconductor Physics, the Institute of Physics, the Institute of Physical Chemistry, and others). Later, those researches formed a basis for the creation of several scientific schools united under the title “Semiconductor surface science”. These were the physics of real semiconductor surface headed by Prof. V.I. Lyashenko, the physics of metal–semiconductor interface headed by Prof. V.I. Strikha, the physics of atomically clean surface headed by Academician of the NASU, Prof. N.G. Nakhodkin, and the physics of surface-sensitive semiconductor sensors headed by Prof. V.V. Serdyuk. Below, some important, from my viewpoint, results obtained during the years of Ukraine’s independence (1991–2016) are discussed.

2. New Results Obtained during the Independence Years of Ukraine by the Scientific School of the Physics of Real Semiconductor Surface Headed by V.G. Litovchenko

Physics of real semiconductor surface studies the phenomena that arise at the surface of semiconductors surrounded by a room gas environment. Since 1989, this scientific school has been headed by the Corresponding Member of the NAS of Ukraine V.G. Litovchenko.

2.1. Effects arising in quantum cathodes (research supervisors: V.G. Litovchenko and A.A. Evtukh)

A number of new effects induced by a strong electric field applied to a real semiconductor surface have been discovered, in particular, for multineedle semiconductor field-emission (FE) cathodes (Fig. 1).

Unlike the ordinary charge transfer in the semiconductor bulk, the FE phenomenon is governed not only by the thermal excitation of free charge carriers and the influence of an internal barrier, but also by additional mechanisms of current formation; first of all, by the crucial influence of the quantum-mechanical tunneling of charge carriers through the surface barrier. Unlike metal cathodes, electrons in semiconductor field-emission cathodes are heated up, and the effect of a field-induced intervalley carrier redistribution in wide bandgap semiconductors (GaN, ZnO) was observed. For the first time, this effect was studied in needle-like structures, the so-called “quantum cathodes” (QCs) [1–3]. The Fowler–Nordheim formula and Fig. 2 illustrate these quantum-mechanical mechanisms of work function reduction as a result of the population of highly located (the so-called satellite) valleys. The work function for the latter is much lower than that for the main band of free electrons. Hence, a drastic growth of the field-emission current is predicted.

A number of new effects were predicted by Ukrainian physicists in 1992. Some of those effects were already observed during the independence years. For example, an important role is played by variations in the electron spectrum of semiconductor QCs. They result in the spectral changes of emitting electrons, up to the emergence of their quasimonochromatic energy distribution.

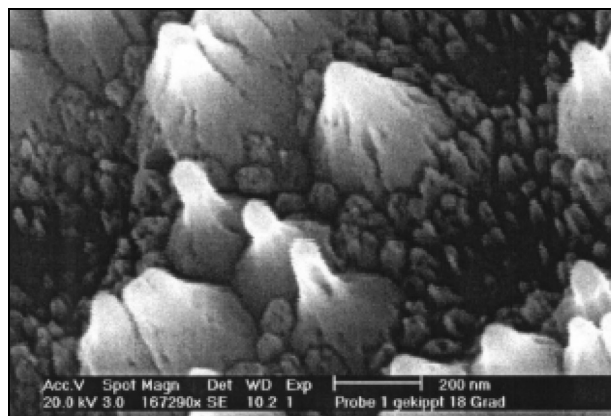

Puc. 1. SEM image of a GaN nanocathode obtained by selective etching [2]

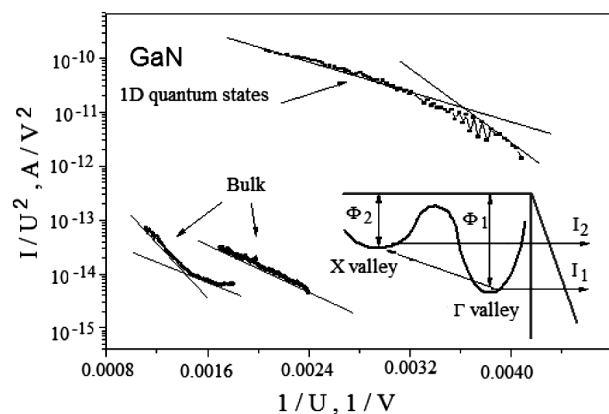

Puc. 2. Experimental I – V characteristics for electron field emission from GaN plotted in the Fowler–Nordheim coordinates

Under quantum-mechanical conditions, the character of heated-up charge carriers changes. Namely, their slowed cooling, the so-called “phonon bottleneck” for the quantization, is predicted. Therefore, there appears the opportunity to observe the phenomenon of hot-carrier redistribution between the valleys at high frequencies. In other words, the possibility to observe the Gunn effect in wide-gap semiconductors (of the GaN type) was predicted.

Hence, during the last 25 years:

1. A generalized theory of field-emission current from both valleys was developed. The theory allows the current-voltage characteristics with two slopes in the Fowler–Nordheim coordinates to be explained. The theoretical results are in good agreement with experimental current-voltage curves and make it

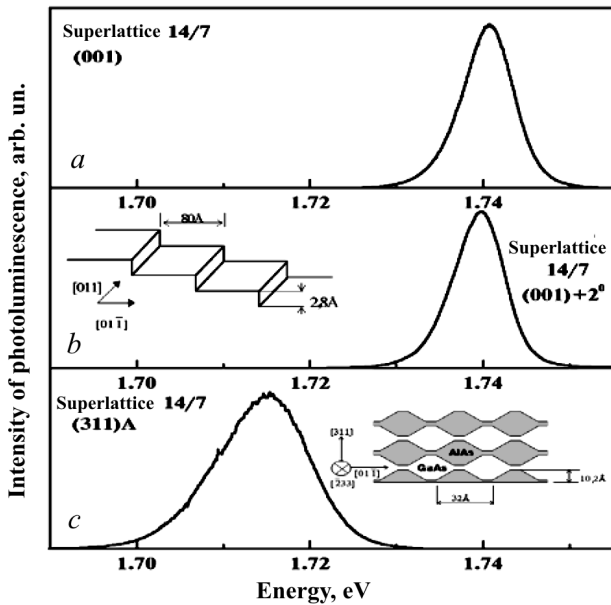

Fig. 3. Photoluminescence spectra of GaAs/AlAs 14/7 superlattices (14 is the number of GaAs monolayers, and 7 the number of AlAs monolayers) grown up on wafers with various orientations: (001) (a), (001) disoriented by 2° in the $\langle 110 \rangle$ direction (b), (311)A and (c). $T = 4.2$ K. The insets in panels (b) and (c) schematically illustrate interface corrugations that are typical of corresponding wafer orientations

possible to determine the distance between the valleys (Fig. 2) [1–3].

2. Quantum cathodes were proposed. They are characterized by a number of useful properties. In particular, those cathodes provide a drastic increase of the cold emission current. In the case of multivalley semiconductors, they have sections with different slopes in their current-voltage characteristics plotted in the Fowler–Nordheim coordinates. The properties of low-dimensional semiconductor cathodes are governed by the size-quantization of their band structure, a quasidelta-like spectrum of the electron density of states, the nondegenerate statistics for free charge carriers, specific features of the free electron heating in different valleys, and, first of all, tunneling processes through the vacuum barrier.

Making allowance for those fundamental factors enabled the major properties of quantum cathodes to be described. A comparison of theoretical results with experimental ones carried out for the multivalley semiconductor with a wide energy gap (GaN) made it possible to determine its band parameters and predict

the δ -like monochromatic emission of electrons from quantum cathodes.

For quantum cathodes fabricated from a perfect bulk material, the current-voltage characteristics with two slopes in the Fowler–Nordheim coordinates were measured (Fig. 2). The inset in Fig. 2 schematically illustrates the energy band diagram for a two-valley semiconductor. As a result of the theoretical analysis and experimental researches, the population of a satellite valley was observed for the first time. Hence, the principal possibility to create Gunn-type microwave generators on the basis of quantum cathodes fabricated from wide-bandgap semiconductors (GaN, ZnO) in the variant of pixel emitters with low resistance was demonstrated.

2.2. New surface effects in quantum-size superlattices (research supervisor: D.V. Korbutyak)

The method of polarized photoluminescence was applied for the first time, while studying the interfaces between quantum superlattices (SLs). For this purpose, the GaAs–AlAs interface was used. The importance of such researches is associated, first of all, with a possibility to obtain information on the fundamental properties of such quantum structures – namely, the perfection of the quantum well-barrier layer interface – as well as with a prospect to use polarization-sensitive effects in optoelectronic devices created on the basis of those structures.

In works [4, 5], the anomalous polarization of the photoluminescence in quantum SLs was observed for the first time. This phenomenon was not predicted by the theories that existed at that time. The new effect is associated with the existence of an ordered microrelief at the GaAs–AlAs heterointerface (more specifically, with the corrugated character of the interface profile). The effect turned out sensitive down to the subatomic scale. A quantitative theory of additional linear polarization of the exciton photoluminescence in SLs was developed, and the relations between the linear polarization degree and the geometrical parameters of corrugations were obtained for various microrelief shapes: symmetric, asymmetric, and sinusoidal (Fig. 3). The polarization induced by the interface corrugation can be observed, when the photoluminescence is detected in the direction perpendicular to the surface, i.e. when the contributions

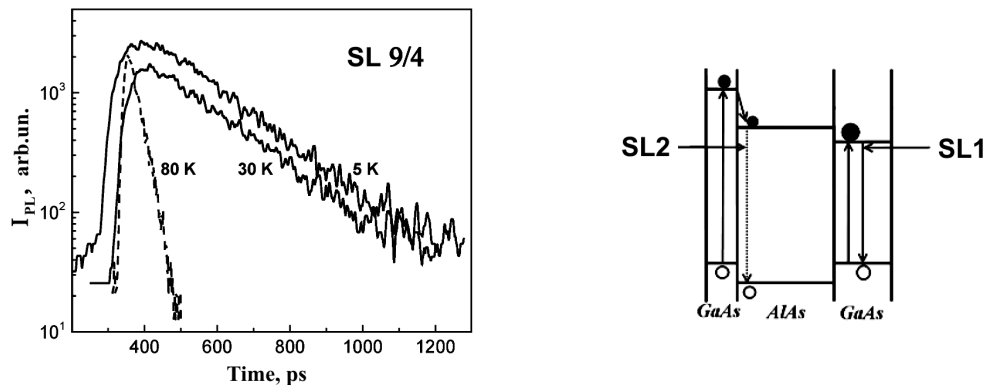

Fig. 4. Time dependences of the photoluminescence intensity maximum for the GaAs/AlAs 9/4 superlattice at $T = 5, 30,$ and 80 K. Right panel schematically illustrates elements of direct-band (SL1) and indirect-band (SL2) superlattices

of other polarization mechanisms (the anisotropy of heavy-hole subband and ordinary light polarization at the crystal-vacuum interface) are absent. The comparison between the experimental and theoretically calculated dependences of the linear polarization degree P on the detection angle was carried out.

Another anomalous effect was also revealed in SLs for the first time, namely, the appearance of long-wave phonon repetition peaks in short-period SLs. A detailed study of this effect showed that the features of the electron-phonon interaction in quantum-size structures result not only from the quantization of electron states (the growth of the exciton binding energy at the quantization $E_{ex} \sim 1/d^2$, where d is the quantum layer thickness), but also from the specific features of a phonon spectrum, in particular, the existence of powerful local and interface phonon modes in it, the influence of which considerably increases, as the thicknesses of the quantum-well and barrier layers decrease. Those phonon characteristics were considered for the first time in works [4–6], together with effects of the electron-phonon interaction in GaAs/AlAs superlattices of the second type (SLs-II), when transitions through the barrier level are engaged, and the SL becomes an indirect-band-gap one. The photoluminescence spectra of such narrow-well SLs-II reveal phonon repetitions of the exciton emission band, which are related to GaAs-AlAs interface phonons. Hence, the intensity of phonon repetitions considerably increases, when the transformation from direct-gap to indirect-gap SLs takes place.

In the case of quasidirect-gap SLs, the anomalous growth of the intensity ratio between the phonon

satellites and the zero-phonon line, when the SL period decreases, testifies to the growth of the electron-phonon interaction in those structures. A good agreement was found between the experimental dependence of the degree of electron-phonon interaction, $\Gamma \sim h/\tau_t \sim N_t$, and the results of a theoretical model developed for shallow centers. The growth of this parameter with a decrease of the SL period is associated with the growth of the exciton binding energy. A practical problem was formulated: How can the structural perfection (or the imperfection degree) of SL and its dependence on the quantum layer thickness be estimated on the basis of the parameter Γ ?

The time-resolved researches of the photoluminescence spectra for GaAs/AlAs superlattices of various types (direct-gap, quasidirect-gap, indirect-gap) in a wide temperature interval made it possible to establish the basic features of recombination processes that run in those structures [7]. In particular, in excited direct-gap SLs with the well thickness of an order of exciton radius, free heavy and light excitons, as well as the transition from light to heavy excitons, were observed immediately after the excitation. For SLs of the first type (SLs-I) with the GaAs layer thicknesses less than the exciton radius at low temperatures ($T < 70$ K), the free excitons become localized at the GaAs/AlAs hetero-interface within a time interval of about 150 ps; afterward, they emit to form a new photoluminescence band. In this case, the time of the photoluminescence intensity quenching becomes much longer (Fig. 4). In SLs with even smaller thicknesses of quantum layers, the radiation emission at low temperatures is associ-

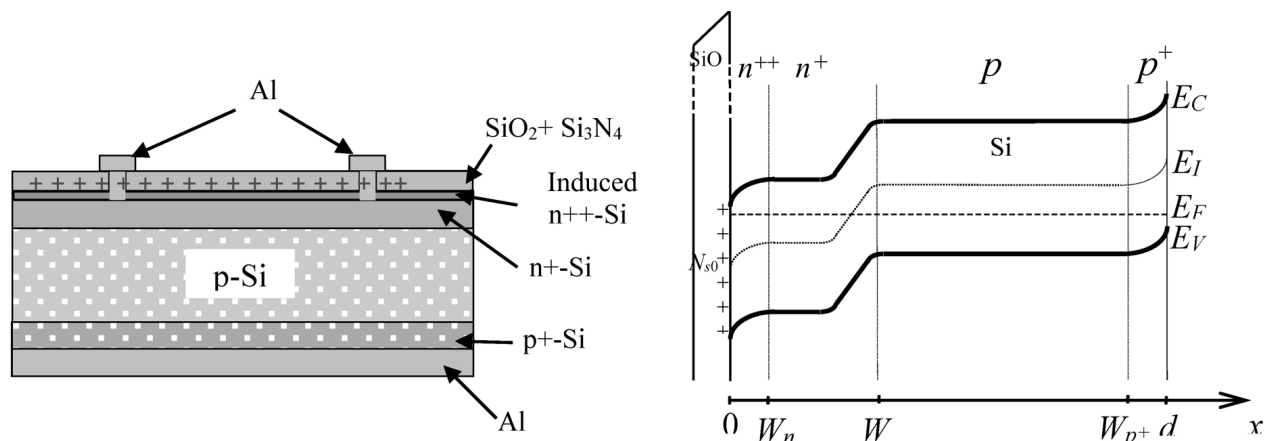

Fig. 5. Silicon-based solar cell with diffusion-field barriers and its band diagram

ated with coupled excitons, the partial delocalization of which begins only if the temperature increases ($T > 80$ K). Finally, in the GaAs/AlAs superlattices with ultrathin layers, the radiation emission by localized excitons is observed in the whole examined temperature interval. The decrease of the well thickness substantially enhances the photoluminescence quenching, which can be explained by the growth of non-radiative losses.

For the cycle of scientific works “Charge and mass transfer processes and the electron kinetic phenomena at the surface and in the near-surface layers of solids”, V.G. Litovchenko, D.V. Korbutyak, M.G. Nakhodkin, A.G. Naumovets, V.M. Dobrovolskyi, and others were awarded the State Prize of Ukraine in science and engineering in 1997.

2.3. New type of silicon solar converters with a surface barrier: achievements in the physics of renewed semiconductor solar power engineering (research supervisors: A.P. Gorban' and V.P. Kostilyov)

A general theory of semiconductor photo-electric solar converters, which considers the influence of the main surface recombination processes on the reduction of the photo-electric conversion efficiency, was developed. These are surface recombination (local Shockley–Reed centers), impact Auger processes, radiation emission, excitonic processes, and the influence of induced surface barriers of various nature on the increase of the efficiency of solar

photoconverters. A general algorithm was proposed to optimize the design of solar cells to various operational conditions: on land and in space, for focused or scattered light. Various constructions for mono- and heterojunctions were also proposed [8–15].

In the framework of the National space program of Ukraine, a research and development project was executed. It concerned the development and the manufacture of a set of solar batteries to be used in the power supply system of the first Ukrainian new-generation space vehicle as a primary energy source. The batteries were fabricated with the use of solar cells (SCs) developed by the team of the department headed by A.P. Gorban'. They are characterized by a sufficient electric power, which can be delivered under the AM0 conditions. The solar batteries were mounted on the flight specimen of the space vehicle KS5MF2 “Mikron”, which was successfully launched in December, 2004 (A.P. Gorban', V.P. Kostilyov, A.V. Makarov, A.A. Serba, and B.F. Dverniov, 1994–2004).

The originality of photoconverters developed at the V.E. Lashkaryov Institute of Semiconductor Physics of the National Academy of Sciences of Ukraine consists in the creation of a surface barrier. This principal feature is illustrated in Fig. 5. The physical principles of functioning, as well as the designs for SCs and batteries of a new type with surface barrier, were developed. Those devices are characterized by an enhanced efficiency. They are intended to be used in solar accumulating blocks for the power supply of ground- and space-based radio-electronic

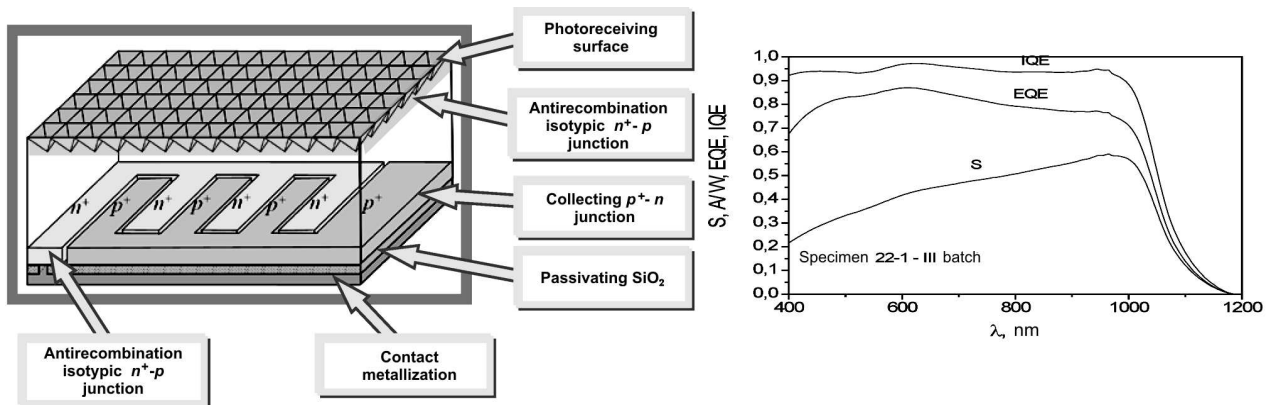

Fig. 6. Schematic diagram of a silicon solar cell with the rear arrangement of barriers and current collecting contacts (left panel), and its spectral sensitivity (right panel)

facilities [8–10]. Besides that, they are applied in the professional dosimetric and radiometric equipment of a new generation, which was created by the request of the Ministry of Emergency Situations of Ukraine and operates under field conditions (1997–1999).

A general physical theory describing the functioning of SCs was developed. It describes the surface recombination of various nature in surface-barrier silicon solar cells, as well as its dependence on the light illumination level, the doping level, and the surface charge. In particular, it was shown that, in the case of depleting band bending at the surface, the effective rate of surface recombination decreases with an increase of the injection level Δn , if this level exceeds the concentration of minority charge carriers in the base. On the contrary, for the inversion or enriching band bending at the silicon surface, the effective rate of surface recombination does not depend on the light illumination level until the injection level exceeds the concentration of majority charge carriers in the base; then it starts to increase linearly with the illumination level.

For the first time, the theory was created for a new type of silicon SCs with rear metallization (Fig. 6). The efficiency of those cells under a focused illumination was calculated. The dependences of key parameters of those SCs on the degree of the solar illumination focusing, short-circuit current, open-circuit voltage, and photoconversion efficiency were obtained. An original design was developed, and the experimental specimens of silicon SCs with rear metallization were fabricated [11].

For the first time, the theoretical calculation of the limiting efficiency was carried out for various designs of solar cells with quantum wells making allowance for the surface recombination that takes place at the interfaces between the quantum wells and the basic silicon material. It was shown that the surface recombination rate is lower, and the photoconversion efficiency is higher, if the difference between the lattice constants of the quantum-well and basic materials is smaller.

On the basis of the computer code SimWindows, the photoconversion efficiency of direct-gap photo-sensitive A_3B_5 compounds with quantum wells and its dependences on the doping and illumination levels were numerically calculated. Conditions, at which the efficiency of photoconversion in SCs with quantum wells is higher than that in standard SCs, were found.

The physical mechanisms were analyzed, and the theory of modern SCs fabricated on the basis of heterostructures with amorphous silicon (a-Si:H/c-Si) was developed [12, 13]. A good agreement of theoretical results with experimental data at temperatures above 200 K was obtained.

The limiting efficiency of photoconversion in multi-junction SCs was calculated in realistic approximations. It was shown that the proposed theory provides a better agreement with the experiment in comparison with previous theories. As a practical yield of the activity dealing with SCs, mobile solar power plants (10–40 W) were designed and fabricated. Those plants make it possible to feed and to charge a wide range

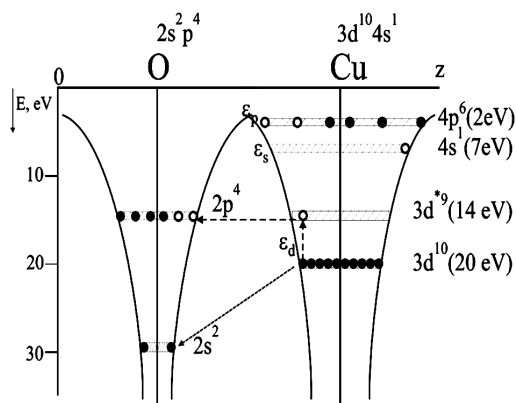

Fig. 7. Electron energy diagram of a Cu–O cluster

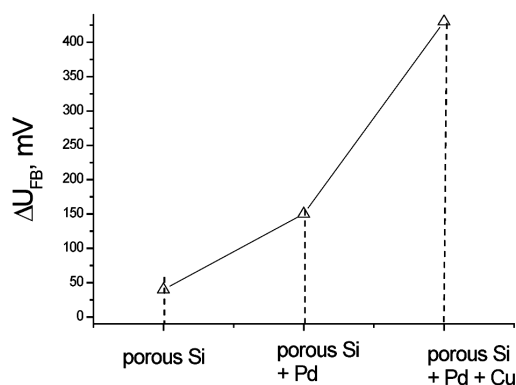

Fig. 8. Influence of copper nanoclusters on the potential change at the MIS structure surface fabricated on the basis of porous silicon before hydrogen adsorption (150 ppm)

of facilities (radio stations, mobile phones, infrared scanners, tablets, GPS navigators) under the field, extreme, and war conditions (the development together with department No. 9, B.M. Romanyuk's group) [14, 15].

For a cycle of scientific and applied works on solar photoconverters, two State Prizes of Ukraine in science and engineering were awarded: in 2007 and 2013.

2.4. New class of effective gas sensors on the basis of nanoclusters of transition metals with oxidized surface (research supervisors: V.G. Litovchenko and T.I. Gorbanyuk)

A new approach was proposed for the production of catalytically active systems, in which cheap

transition metals and their oxides are used. Those substances (Cu, W, WO_3 , Cu_2O , In_2O_3 , SnO_2 , and others) are inactive in ordinary, i.e. bulk, phases, but catalytically active in nano-dimensional structures. A concept about modifications in the structural configuration of electron levels and the character of their hybridization at the formation of supersmall clusters of transition metals and their oxides (or, in the more general case, in compounds with acceptor elements, such as F, Cl, S, and O) serves a theoretical basis for the corresponding developments. Those modifications arise owing to the appearance of free (completely filled beforehand) *d*-orbitals in nano-clusters. These orbitals are the most active at the dissociation of adsorbed molecules and, accordingly, at the catalytic splitting of molecules. From this viewpoint, the modification of a sensitive material by purposefully changing its surface state – e.g., the introduction of transition metal atoms as impurities into the composition of basic semiconductor oxide and/or the filling of pores in the nanoporous matrix by nanoclusters of transition metals and their oxides to create a material that would be sensitive and selective to a certain type of gas molecules – seems to be the most promising technology.

A new mechanism was proposed for the formation of a catalytic active structure. It is illustrated in Fig. 7: When in a contact with the atom of a transition metal, an acceptor component (O, S, F, and so on) can reduce the occupation numbers of *d*-orbitals in it.

Classical catalytic transition metals are expensive, as a rule. A technology of catalyst formation from inexpensive transition metals was developed, in which the change in the *d*-orbital population at the formation of “transition metal–acceptor element (oxygen)” clusters is made allowance for. Experimental results obtained for the structures of nano-sized porous silicon doped with oxidized nanoclusters of copper, tungsten, nickel, and some other metals testify to the appearance of the catalytic activity with respect to ecologically harmful gases (hydrogen sulfide, hydrogen) (Fig. 8).

The phenomenon of the accelerated drift of spatially separated radiation defects was established in terms of ultrasonic excitation. A new method of acoustic-stimulated ion-beam doping is proposed for applications in UJP, 2015, **60**, No. 1. Responsible executives: B.M. Romanyuk, V.P. Melnyk, Ya.M. Olikh.

2.5. Nonconventional mechanism for the formation of a system of silicon nanocrystals on the wafer surface (research supervisors: I.P. Lisovs'kyi and I.S. Indutnyi)

A nonconventional method was proposed for the formation of silicon nano-crystallites by means of the thermally induced phase separation in films of metastable oxide SiO_x . In particular, silicon inclusions are formed as a result of the enhanced diffusion of oxygen atoms from weakly oxidized complexes $\text{SiO}_y\text{Si}_{4-y}$ to stronger oxidized ones. Silicon-enriched molecular complexes SiOSi_3 lose oxygen and, if being heated at 700–1100°C, are transformed into molecular silicon tetrahedra SiSi_4 . The released oxygen atoms diffuse and transform oxygen-enriched molecular complexes SiO_3Si into SiO_4 tetrahedra. As a result of this scenario [18], there emerge silicon nano-inclusions surrounded by dioxide (SiO_2) layers (Fig. 9).

The proposed mechanism is confirmed by the analysis of the form that acquires the band of IR absorption at Si–O bonds [1] and by the results of researches dealing with the kinetics of phase separation [18].

3. Works of the Scientific School of the Physics of Semiconductor Surface in Contact with Metal Headed by V.I. Strikha (Research Supervisors: Prof. V.I. Strikha and Prof. V.A. Skryshevsky)

At the Chair of semiconductor physics of Taras Shevchenko National University of Kyiv, Prof. V.I. Strikha created a scientific school dealing with the studies of metal-semiconductor interface phenomena. In the framework of this school, the theory of “real” Schottky contact with an intermediate dielectric layer was developed. Under the V.I. Strikha supervision, works on the creation of biosensors on the basis of Schottky diodes; metal-semiconductor-insulator structures; field-effect transistors for detecting pesticides, glucose, urea, and other organic and inorganic substances were performed for the first time [19].

Later, the works aimed at the creation of chemical sensors were actively continued both at the Chair of semiconductor electronics headed by Prof. O.V. Tretyak and, since 2009, at the Chair of nanophysics of condensed media (the Institute of High Technologies) headed by Prof. V.A. Skryshevsky. In particular,

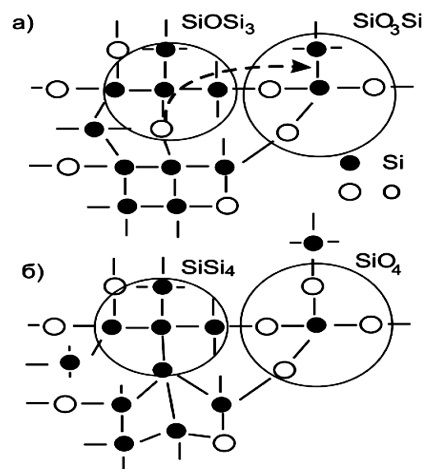
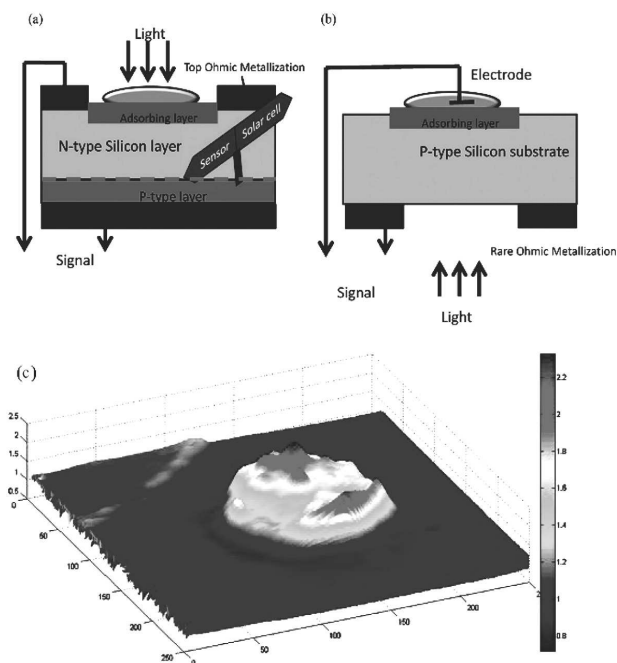

Fig. 9. Silicon nano-inclusions surrounded with a silicon dioxide (SiO_2) layer

the generalized theory was developed for chemical sensors on the basis of surface-barrier structures with an intermediate layer of thin porous semiconductors and nano-catalysts [20,21]. The influence of nanoparticles of noble metals on the electric properties of nano-porous silicon was studied [22,23]. New types of effective chemical sensors were developed for detecting hydrogen, moisture, hydrogen-carbon compounds, heavy metals, and organic media, in which the luminescent or electric transducers on the basis of surface-barrier structures from porous silicon, titanium oxide, graphene, and other nanosubstances were applied [24–27]. The influence of surface states on the kinetics and the sensitivity of chemical sensors on the basis of Schottky structures was established [28].

Together with the National Institute of Applied Sciences of Lyon (France), a photo-electric sensor (an “electronic tongue”) was created, which can be used for detecting various substances in air, foodstuff, liquids, and so forth. Its work is based on the application of heterostructures that are based on a silicon wafer. Under the influence of light, the sensor generates an electric signal, the parameters of which are very sensitive to the chemical composition of substances (Fig. 10). The development is protected by an international patent, with Taras Shevchenko National University of Kyiv being its co-owner, and was published in the high-rank interdisciplinary journal “ACS Applied Materials and Interfaces” (<http://pubs.Acs.Org/doi/abs/10.1021/>



Puc. 10. Basic design of an “electronic tongue” on the basis of a photo-electric transducer (a, b) and the experimental 2D distribution of the induced current with a droplet of distilled water on the rear side of a $p-n$ junction (c)

am5058162). The American Chemical Society (ACS) issued a press release to inform the business and scientific community about this development of the scientists of the Institute of High Technologies.

A method was proposed for the creation of electronic imprints of liquids. It is based on a change in the lifetime of nonequilibrium charge carriers at their adsorption on the semiconductor surface. The method is also protected by an international patent (Fig. 11).

Technologies aimed at increasing the efficiency of silicon-based photo-electric converters (PECs) owing to the application of nanomaterials were proposed and implemented. In particular, the application of passive layers of porous silicon (PS) to increase the efficiency of PECs of the diffusion type as an anti-reflecting coating, a passivating layer for the emitter, and a converter of ultra-violet sunlight into visible radiation was substantiated both theoretically and experimentally. A substantial growth of the short-circuit current in PECs of the $p-n$ type based on polycrystalline silicon and the short-wave quantum PEC efficiency due to the reemissi-

on in PS were demonstrated. A positive role of the Rayleigh light scattering in PS was shown. A design of a thin PEC with scattering PS inclusions was proposed. Experimental specimens of highly effective PECs of the $p-n$ type based on polycrystalline silicon with a system of selective PS diffusers on the emitter surface and rare Bragg mirrors were fabricated. In 2012, for the results of this work, V.A. Skryshevsky together with his colleagues from the V.E. Lashkaryov Institute of Semiconductor Physics of the NASU were awarded the State Prize of Ukraine in science and engineering.

4. Scientific Achievements of the Scientific School Headed by M.G. Nakhodkin in the Physics and Electron Spectroscopy of Atomically Clean Semiconductor Surfaces

Scientific researches dealing with the physics and the electron spectroscopy of semiconductor surfaces, which are carried out under the supervision of Mykola Grygorovych Nakhodkin, were proceeded from the study of interaction processes between medium-energy electrons and soft x-ray radiation, on the one hand, and solids, on the other hand. As a result of the researches aimed at the study of differential parameters of the elastic electron reflection, it was found that the analysis of the spectral form for characteristic energy losses of electrons makes it possible not only to study the scattering of medium-energy electrons in the near-surface layer of the substance, but also determine the spatial characteristics of the electron subsystem in this layer. This possibility has an important value for the diagnostics of the electron gas state near the surface of base structures of solid-state and nanoelectronics.

The nature of the extended fine structure was studied, and the dependence of the elastic reflection coefficient of electrons on their energy was determined. The diffraction nature of the structure concerned was established. On the basis of the results obtained, a surface-sensitive method for the study of short-range order parameters in disordered solids was proposed. The method is protected by author's certificate [29]. It was used to study Si, GaP, Si + Bi, and other surfaces, which were either disordered with the use of argon ions or created in vacuum [30, 31].

A method of ionization spectroscopy (IS) was invented, which turned out informative with respect

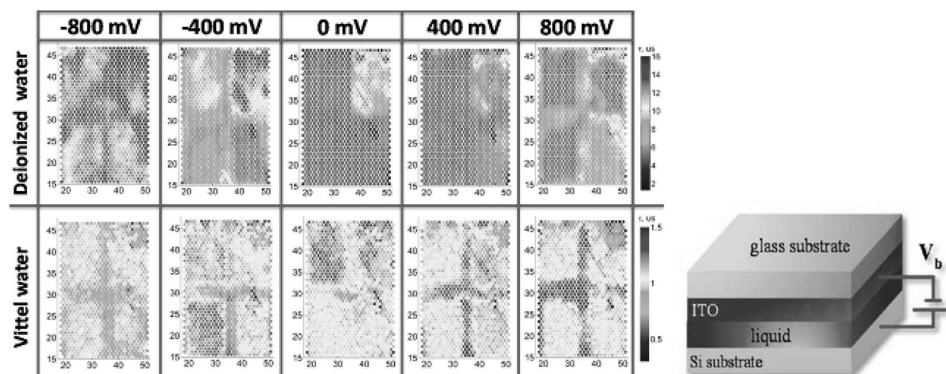

Fig. 11. Electronic imprints of deionized water and Vitell water obtained on the surface of p -silicon modified by nano-SiN_x rectangles at various polarization potentials (a). Sandwich structure used for the polarization of the silicon–liquid interface (b)

to the determination of the density of unfilled states in the near-surface layers of solids, the chemical environment, the integrity of monoatomic layers, and so forth. Apprehensive researches of the semiconductor surface interaction with foreign atoms were performed. The possibilities and problems of IS were described in book “Ionization spectroscopy” [32] and the electronic edition of the handbook “Atlas of ionization spectra”. The latter was placed in the Internet, and it is permanently enriched with new ionization spectra of elements and compounds, in particular, silicon [33].

The method of scanning tunnel microscopy was improved. Unique ultrahigh-vacuum scanning tunnel microscopes, the first in the CIS, were created, which made it possible to study the processes on a solid surface at the atomic level, to observe separate atoms, and, sometimes, to control their behavior [34–36]. In particular, it has been possible to directly monitor, for the first time, the adsorption of hydrogen atoms in deep holes at the Si(111) – 7×7 unit cell corners, as well as to study a complicated motion of dimers and the processes of nanostructure self-assembling on the surface of Si(001) – 2×1 face with a high time resolution. Two- and three-dimensional spontaneously nano-structured Bi/Ge(111) interfaces and graphene monolayers on Ge(111) were obtained. New elements in the reconstruction of the Ge(111) surface were revealed; in particular, these are corner holes, which are similar to those observed in the regular Si(111) – 7×7 structure (Fig. 12) [37, 38].

The electronic and adsorption properties of low-index facets of silicon and germanium with various ordering degrees were studied both experimentally and

theoretically, as well as the formation of silicon interfaces with transition metals and elements of the fifth group of the Periodic system [39–42]. The methods of quantum chemical computer simulation were introduced, and an involved motion of adsorbed atoms and dimers, as well as the processes of nanostructure self-assembling on the Si(001) and Ge(100) surfaces, were analyzed [43, 44].

Detailed researches of the structure of polycrystalline silicon films and its dependences on the deposition conditions and conditions at the further stages of a technological treatment were performed, which is a topical issue from the viewpoint of a wide application of those films in the solar power engineering. The mechanisms and the driving forces of normal and abnormal grain growth in films at the annealing were determined, phase modifications in the films with fibrous and dendritic structures were studied, and the influence of the structure type of silicon films on the processes of their oxidation were analyzed [45, 46].

A new direction in structural researches – researches dealing with the grain boundary structure in semiconductor materials – is actively developed. The types of grain boundaries in polycrystalline silicon films and grain boundary joints together with their dependence on the film structure type (equiaxed, fibrous) were analyzed, as well as the grain boundary faceting transformations of twin grain boundaries and twin interlayers in the grains of polycrystalline silicon films. The facet types in polycrystalline silicon films were classified, and the stability diagrams for various facet types were plotted. A temperature interval of 1150–1200 °C was determined to be optimum for

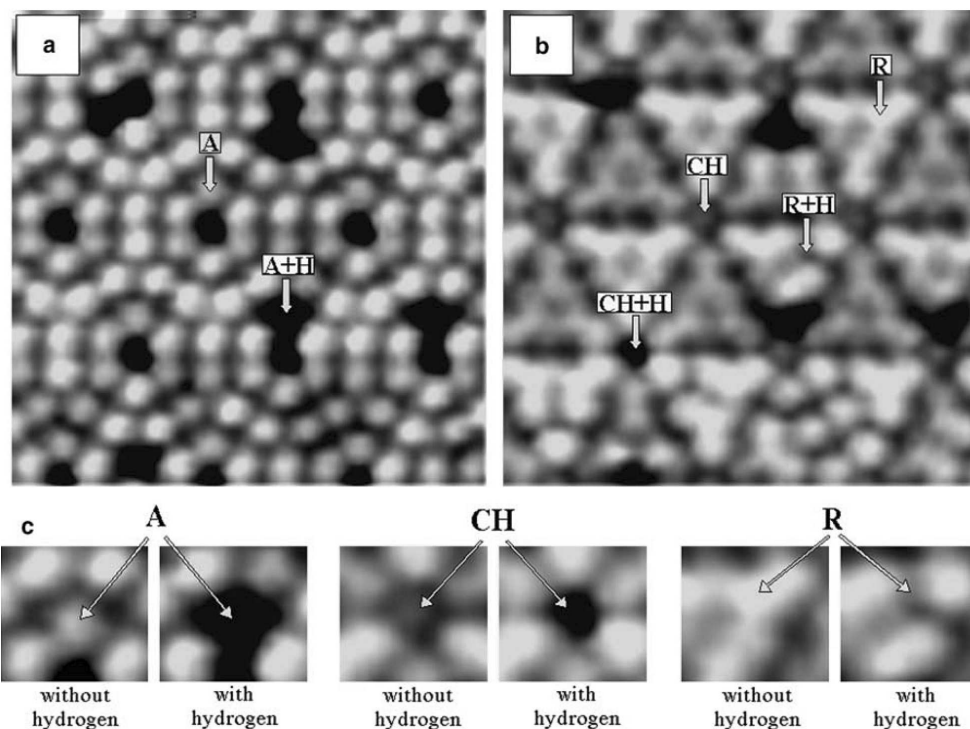

Puc. 12. Typical STM images of the same area on the H/Si(111) – 7×7 surface at positive (1.2 V, 56 pA) (a) and negative (–1.2 V, 56 pA) (b) voltages on the specimen. Images were obtained, by using Bi/W tips. Places of hydrogen adsorption: adatom (A), residual atom (R), and corner holes (CH). The scaled-up variants of those images [37] (c)

the annealing of polycrystalline silicon films in order to form facets of the type $\Sigma = 3\{111\}_1/\{111\}_2$ (or $(100)_{\text{CSL}}$). The latter have the minimum concentration of traps for charge carriers and are favorable for the functionality improvement of devices based on polycrystalline silicon [45–47].

Under ultrahigh vacuum conditions, using the methods of photoelectron spectroscopy, Auger electron spectroscopy, and low-energy electron diffraction, researches of the influence of surfactants (As, Sb, Bi) on the electronic and adsorption properties of atomically clean low- and high-index facets of silicon and germanium were carried out. Their results are used to optimize the surfactant influence on the processes of metal-semiconductor interface formation.

It was found that a series of adsorption cycles with Gd and oxygen atoms on the Si(100)- 2×1 surface followed by the annealing of the obtained structure at about 600°C resulted in a reduction of the surface work function for the Si surface from 4.8 eV to values lower than 1 eV. A decrease of the work function wi-

th an increase of the cycle number was accompanied by the oxidation of Gd and Si atoms, as well as a gradual reduction of the Si concentration in the near-surface region. The obtained results were explained by the formation of Gd oxide in the near-surface layer. The work function of this surface almost does not change under ultrahigh vacuum conditions and can easily be restored by the annealing after the holding of it in the room environment. It is the outer layer of Gd atoms that is responsible for the work function reduction: it creates a dipole layer (O-Gd) near the surface [48]. The system Si-Gd-O with a low work function can be used for the creation of sources of spin-polarized electrons and efficient photo-emitters in the ultra-violet spectral range.

The results of scientific developments were embodied in the training of students at the Chair of nanophysics and nanoelectronics, in particular, in the lecture courses, practical training, and laboratory sessions in the framework of the courses “Physical basis of electronics”, “Physical electronics”, “Modern methods

of surface diagnostics”, “Surface science”, “Scanning tunnel microscopy”, “Computer experiment”, and others. The importance of those courses under the information society conditions is undoubtful, which is also confirmed by the analysis of curricula in similar specialities at leading higher educational institutions of the USA, Western Europe, and China.

5. Works of Prof. V.V. Serdyuk’s Scientific School “Surface-Sensitive Semiconductor Sensors” (Today, This School is Headed by Prof. V.A. Smyntyna)

Semiconductor researches at the Odesa University were started by Professor Elpidifor Anempodystovych Kirillov in the 1930–1940s. E.A. Kirillov was the head of the Chair of experimental physics and the Director of the Scientific and Research Institute of Physics (it was the first institute in Ukraine created in the framework of the Ministry of the higher and specialized secondary education). Owing to his efforts, the first All-Union conference on semiconductor physics was held on the basis of Odesa University. This fact reflected an important role of physicists from the city of Odesa in the development of the researches of semiconductor materials as early as that time. The scientific school “Problems of semiconductor physics”, including surface science, was ultimately formed at I.I. Mechnikov State University of Odesa under the supervision of Prof. Viktor Vasylyovych Serdyuk, the Head of the Chair of experimental physics in 1968–1994. He had created a powerful personnel potential for his scientific school. Three theses for the doctoral degree (V.A. Smyntyna, D.L. Vasylevs’kyi, and Yu.F. Vaksman) were defended under his supervision.

In 1970 at the Chair “problems of semiconductor physics”, the first researches of the semiconductor surface interaction with atoms and molecules in the environment were started. The first generalizations concerning the interaction on the semiconductor surface and at semiconductor interfaces gave rise to the creation of an original direction in the researches of surface phenomena. The results obtained were summarized in V.A. Smyntyna’s thesis for the doctoral degree “Electrophysical, photo-electric, and chemisorption-diffusion processes at the interface between selenide- and cadmium-sulfide semiconductor films” (1988). Simultaneously, the applied works were actively carried out, in which the revealed regu-

larities were used to control the surface properties and create gas and optical image sensors. In 1994, Prof. V.A. Smyntyna became the Head of the Chair of experimental physics. Since then, he is heading the scientific school “Problem of semiconductor physics” at the Odesa University.

Professor V.A. Smyntyna initiated the creation of two scientific and research laboratories at the University: “Sensor electronics and technologies” and “Electron-molecular processes on the semiconductor surface”, which promoted the active development of researches of surface phenomena. Later, on the basis of those laboratories, an Interdepartmental Scientific-Educational Center of Physics and Technology was created. The journal “Sensor Electronics and Microsystem Technology” (with Prof. V.A. Smyntyna being its Editor-in-Chief) and a recognized international conference with the same title were founded.

The works on the adsorption and sensorics were awarded the State Prizes of Ukraine in science and engineering: V.A. Smyntyna (2007), Sh.D. Kurmashev (2009), and Ya.I. Lepikh (2011). Two representatives of the scientific school (V.A. Smyntyna and Ya.I. Lepikh) were awarded the honorary title “Honored Worker of Science and Engineering of Ukraine”.

A considerable body of the results obtained was summarized in books [49, 50]. They were also taken as a basis for the textbooks for physics students [59–61] and published in scientific papers [62–68]. The following fundamental achievements should be mentioned: [49–68].

1. A new type of the electric inhomogeneity on the semiconductor film surface – the chemisorption-electric domain – was revealed. The chemisorption mechanism of its formation was substantiated. Its responsibility for dark current oscillations, saturation, negative differential resistance of current-voltage characteristics, and some other phenomena was demonstrated.

2. A phenomenological theory of semiconductor adsorption sensitivity (AS) was developed and implemented. The theory served as a basis for the introduction of a universal determination of the adsorption sensitivity parameter and for the development of the methods aimed at predicting the regions, where the maxima of the electric AS appear for various semiconductors and under various operational conditions (V.A. Smyntyna and Yu.A. Vashpanov).

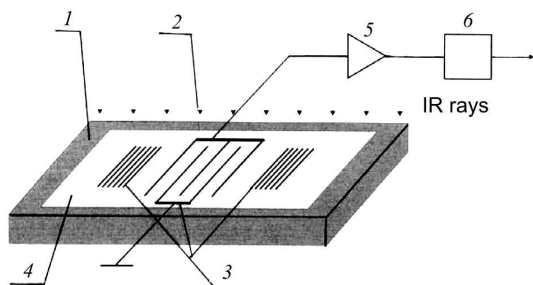

Puc. 13. Block diagram of an IR radiation sensor: piezoelectric LiNbO_3 wafer with an orientation of 128° Y-X cut (1), interdigital resonance structure (2 and 3), photosensitive semiconductor (InSb) layer (4), amplifier (5), signal processing device (6)

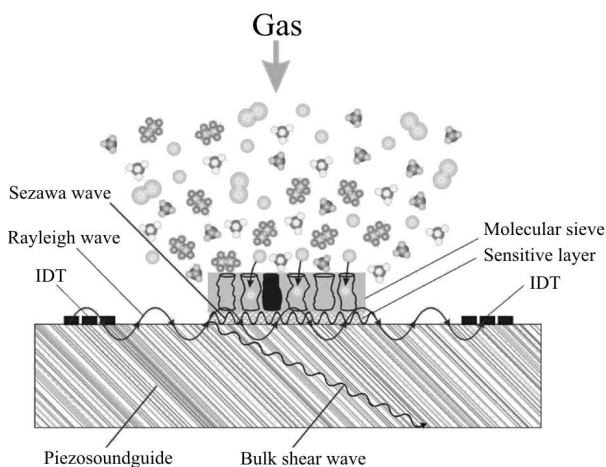

Puc. 14. Layered structure with a molecular sieve on the piezoelectric surface used as a gas sensor

3. The modification in the surface chemical composition during the film growth was shown to be the main driving force of the mechanism responsible for the non-monotonic conductivity dependence on the thickness of an adsorption layer. A possibility for the chemisorption of particles of the same type to differently affect the photoconductivity (sensitization/desensitization) was demonstrated. It was shown how surface impurities can enhance AS and selectivity of the sensor surface.

4. Using the direct XPS, SIMS, and Auger spectroscopy methods, it was proved that oxygen atoms and molecules in the energy gap on the semiconductor film surface form the levels of electron sticking in energy intervals of 1.1–1.4 eV and 0.7–0.9 eV. Their kinetic and geometrical parameters were determined.

5. A new property of macro-, micro-, and nanoporous silicon – namely, adsorption sensitivity – was revealed and interpreted. Its magnitude was shown to depend on the presence and the degree of impurity cluster dispersion on the silicon surface.

6. The mechanism of interaction between CdS quantum dots and a biological matrix was discovered. The former play the role of a non-electric signal converter with the emission of luminescence radiation. A ZnS nanoshell around CdS nanocrystals enhances their sensitive properties in the ZnS-CdS nano-heterojunction.

7. On the basis of the ALD technology, nanosensitive structures on the basis of ZnO and TiO_2 , as well as AlZnO-TiO_2 composites, were fabricated. Physical mechanisms of the selective sensitivity of their surface to complex biological objects and phenomena – in particular, to leukemia and salmonellosis – were determined. The origin of the centers on their surface, which govern the intensity and the spectral composition of their luminescence, was established. The physical and biological aspects were revealed that are responsible for an extreme selectivity of biophysical sensors associated with the interaction of the key-lock type.

8. Regularities in the interrelations between the structure, electrophysical parameters, and acoustic characteristics of insulators and layered structures applied in acousto-electronic transducers operating on surface acoustic waves were found.

A theory of charge transfer through the interface in heterojunctions was developed. On its basis, new nano-heterosystems for the image registration were created, and the origin and the parameters of surface centers responsible for the accumulation and the storage of optical information were determined (V.A. Smyntyna, V.A. Borshchak, Ye.V. Brytavskiy, and D.L. Vasylevskiy).

On the basis of the examined surface phenomena and their revealed mechanisms, adsorptionally sensitive elements were created. They can be used as gas sensors to register gases of various types: O_2 , SO_2 , H_2S , NO , NO_2 , NH_3 , and others (see Figs. 12 and 13).

Very challenging is a new direction in sensorics: the application of materials and structures that are sensitive in the far-IR spectral range in devices operating without cooling [68, 69].

The author expresses his gratitude to D.V. Korbutyak, A.A. Evtukh, V.P. Kostylyov, T.I. Gorbanyuk, V.A. Skryshevsky, I.P. Koval, V.A. Smyntyna, and Ya.I. Lepikh for providing the material and assisting the preparation of the manuscript.

- V. Litovchenko, A. Evtukh. Vacuum nanoelectronic. In *Handbook of Semiconductor Nanostructures and Nanodevices*, edited by A.A. Balandin, K.L. Wang (American Scientific Publishers, 2006).
- V. Litovchenko, A. Grygoriev, A. Evtukh, O. Yilmazoglu, H.L. Hartnagel, D. Pavlidis. Electron field emission from wide bandgap semiconductors under intervalley carrier redistribution. *J. Appl. Phys.* **106**, 104511 (2009) [DOI: 10.1063/1.3259384].
- A. Evtukh, A. Grygoriev, V. Litovchenko, O. Steblova, O. Yilmazoglu, H.L. Hartnagel, H. Mimura. Influence of the emitted electron energy distribution from nanocathodes upon the current-voltage characteristic. *J. Vac. Sci. Technol. B* **32**, 02B104 (2014) [DOI: 10.1116/1.4843715].
- V.G. Litovchenko, D.V. Korbutyak, Yu.V. Kryuchenko *et al.* Polarization phenomena in 2D structures with quantum wells. *Phys. Low-Dim. Struct.* No. 10/11, 187 (1995).
- D.V. Korbutyak, S.G. Krylyuk, V.G. Litovchenko *et al.* Analysis of photoluminescence spectra peculiarities of short-period GaAs/AlAs superlattices. *Phys. Low-Dim. Struct.* No. 11/12, 97 (1996).
- V.G. Litovchenko, D.V. Korbutyak, S.G. Krylyuk *et al.* Enhancement of electron-phonon interaction in ultrashort-period GaAs/AlAs superlattices. *Phys. Rev. B* **55**, 10621 (1997) [DOI: 10.1103/PhysRevB.55.10621].
- D.V. Korbutyak, S.G. Krylyuk, V.G. Litovchenko *et al.* Photoluminescence kinetics in quantum superlattices of kinds I and II. *Ukr. Fiz. Zh.* **43**, 124 (1998) (in Ukrainian).
- A.P. Oksanych, V.A. Terban, S.O. Volokhov, M.I. Klyui, V.A. Skryshevsky, V.P. Kostylyov, A.V. Makarov. Modern production technologies of silicon and silicon-based photoelectric converters of solar energy (Mineral, 2010) (in Ukrainian) [ISBN 978-966-7830-IS-0].
- A.P. Gorban', V.P. Kostylyov, V.N. Borschev, A.M. Listratenko. Prospects for development of silicon photoconverters and batteries for space use. *Telecommun. Radio Eng.* **55**, 94 (2001) [DOI: 10.1615/TelecomRadEng.v55.i9.120].
- V.A. Semenovich, N.I. Klyui, V.P. Kostylyov, V.G. Litovchenko, V.V. Chernenko. Compositional modulated DLC films for improvement of solar cells efficiency and radiation stability. *J. Chem. Vapor Deposit.* **5**, 213 (1997).
- A.V. Sachenko, A.P. Gorban, V.P. Kostylyov, A.A. Serba, I.O. Sokolovskyi. Comparative analysis of photoconversion efficiency in the Si solar cells under concentrated illumination for the standard and rear geometries of arrangement of contacts. *Semiconductors* **41**, 1214 (2007) [DOI: 10.1134/S106378260710017X].
- A.V. Sachenko, Yu.V. Kryuchenko, V.P. Kostylyov, A.V. Bobyl, E.I. Terukov, S.N. Abolmasov, A.S. Abramov, D.A. Andronikov, M.Z. Shvarts, I.O. Sokolovskyi, M. Evstigneev. Temperature dependence of photoconversion efficiency in silicon heterojunction solar cells: Theory vs experiment. *J. Appl. Phys.* **119**, 225702 (2016) [DOI: 10.1063/1.4953384].
- A.V. Sachenko, A.I. Shkrebtii, R.M. Korkishko, V.P. Kostylyov, M.R. Kulish, I.O. Sokolovskyi, M. Evstigneev. Analysis of the attainable efficiency of a direct-bandgap betavoltaic element. *J. Phys. D* **48**, 455101 (2015) [DOI: 10.1088/0022-3727/48/45/455101].
- V.G. Litovchenko, V.P. Melnik, B.M. Romanyuk, B.F. Dvernikov, R.M. Korkishko, V.P. Kostylyov, S.M. Musaev, V.G. Popov, V.V. Chernenko. Mobile solar power stations for use in the field. *Visn. Nats. Akad. Nauk Ukr.* No. 11, 59 (2015) (in Ukrainian).
- R.M. Korkishko, B.N. Romanyuk, V.P. Melnyk, V.P. Kostylyov. Mobile device for feeding and charging low-power equipment under field conditions. Patent of Ukraine No. 105847 for useful model. Registered on 04.11.2016 (in Ukrainian).
- V.G. Litovchenko, T.I. Gorbanyuk, V.S. Solntsev, A.A. Evtukh. Mechanism of hydrogen, oxygen and humidity sensing by Cu/Pd-porous silicon-silicon structures. *Appl. Surf. Sci.* **234**, 262 (2004) [DOI: 10.1016/j.apsusc.2004.05.146].
- V.G. Litovchenko, T.I. Gorbanyuk, V.S. Solntsev. New adsorption active nanoclusters for ecological monitoring. In *Nanodevices and Nanomaterials for Ecological Security* (Springer, 2012), p. 297.
- I.P. Lisovskyi, V.G. Litovchenko, I.Z. Indutnyi, D.O. Mazunov, P.E. Shepelyavii. Infrared study of thermally induced phase separation in SiO_x films. *Ukr. J. Phys.* **50**, 249 (2005).
- A.M. Nyamsi Hendji, N. Jaffrezic-Renault, C. Martelet, P. Clechet, A.A. Shlu'ga, V.I. Strikha, L.I. Netchiporuk, A.P. Soldatkin, W.B. Wlodarski. Sensitive detection of pesticides using a differential ISFET-based system with immobilized cholinesterases. *Anal. Chim. Acta* **281**, 3 (1993) [DOI: 10.1016/0003-2670(93)85333-F].
- V.A. Vikulov, V.I. Strikha, V.A. Skryshevsky, S.S. Kilchitskaya, E. Souteyrand, J.-R. Martin. Electrical features of the metal-thin porous silicon-silicon structure. *J. Phys. D* **33**, 1957 (2000) [DOI: 10.1088/0022-3727/33/16/304].
- A.I. Manilov, V.A. Skryshevsky. Hydrogen in porous silicon – A review. *Mater. Sci. Eng. B* **178**, 942 (2013) [DOI: 10.1016/j.mseb.2013.05.001].
- O.L. Syschchuk, V.A. Skryshevsky, O.O. Soldatkin, A.P. Soldatkin. Enzyme biosensor systems based on porous silicon photoluminescence for detection of glucose, urea and heavy metals. *Biosens. Bioelectron.* **66**, 89 (2015) [DOI: 10.1016/j.bios.2014.10.075].
- V.A. Skryshevsky, O.V. Tretiak, V.A. Vikulov, V.M. Zinchuk, F. Koch, Th. Dittrich. Electrical characterization of

- gas sensing devices based on porous TiO₂. *Phys. Status Solidi A* **197**, 534 (2003) [DOI: 10.1002/pssa.200306559].
24. V.A. Skryshevsky, Yu. S. Milovanov, I.V. Gavrilchenko, S.I. Tiagulskiy, A.V. Rusavsky, V.S. Lysenko, A.N. Nazarov. Impedance spectroscopy of single graphene layer at gas adsorption. *Phys. Status Solidi A* **212**, 1941 (2015) [DOI: 10.1002/pssa.201532101].
 25. S. Litvinenko, D. Bielobrov, V. Lysenko, T. Nychporuk, V. Skryshevsky. Might silicon surface be used for electronic tongue application? *ACS Appl. Mater. Interfac.* **6**, 18440 (2014) [DOI: 10.1021/am5058162].
 26. V.A. Skryshevsky, A. Laugier, V.I. Strikha, V.A. Vikulov. Evaluation of quantum efficiency of porous silicon photoluminescence. *Mat. Sci. Eng. B* **40**, 54 (1996) [DOI: 10.1016/0921-5107(96)01572-3].
 27. O. Nichiporuk, A. Kaminski, M. Lemiti, A. Fave, S. Litvinenko, V. Skryshevsky. Passivation of the surface of rear contact solar cells by porous silicon. *Thin Solid Films* **512**, 248 (2006) [DOI: 10.1016/j.tsf.2005.12.053].
 28. I.I. Ivanov, V.A. Skryshevsky, T. Nychporuk, M. Lemiti, A.V. Makarov, N.I. Klyui, O.V. Tretyak. Porous silicon Bragg mirrors on single- and multi-crystalline silicon for solar cells. *Renew. Ener.* **55**, 79 (2013) [DOI: 10.1016/j.renene.2012.12.031].
 29. Method for the research of the surface structure of non-crystalline solids. Patent No. 3917426 (1987) (in Russian).
 30. O. Bondarchuk, S. Goysa, I. Koval, P. Mel'nik, M. Nakhodkin. Short-range order of disordered solid surfaces from elastically scattered electron spectra. *Surf. Rev. Lett.* **04**, 965 (1997) [DOI: 10.1142/S0218625X97001139].
 31. O. Bondarchuk, S. Goysa, I. Koval, P. Melnik, M. Nakhodkin. On the short-range order of the SiO_x (0 ≤ x ≤ 2) surface. *Appl. Surf. Sci.* **255**, 6421 (2009) [DOI: 10.1016/j.apsusc.2009.02.031].
 32. *Ionization Spectroscopy*. Edited by M. Nakhodkin (Lybid', 1992) (in Ukrainian).
 33. <http://www.is.univ.kiev.ua/Software/nSpView.html>.
 34. S.Yu. Bulavenko, I.F. Koval, P.V. Melnik, N.G. Nakhodkin, H.J.W. Zandvliet. STM investigation of the initial adsorption stage of Bi on Si(100)-(2×1) and Ge(100)-(2×1) surfaces. *Surf. Sci.* **482–485**, 370 (2001) [DOI: 10.1016/S0039-6028(01)00804-4].
 35. A. Goryachko, P.V. Melnik, N.G. Nakhodkin, T.V. Afanasjeva, I.F. Koval. New features of the Si(100)-c(4×4) reconstruction observed with STM: suggestion of the structure with lowered symmetry. *Surf. Sci.* **497**, 47 (2002) [DOI: 10.1016/S0039-6028(01)01623-5].
 36. S.Yu. Bulavenko, I.F. Koval, P.V. Melnik, N.G. Nakhodkin. The concerted movements of weakly bonded Bi dimers on the Si(100)2×1 surface. *Surf. Sci.* **507–510**, 119 (2002) [DOI: 10.1016/S0039-6028(02)01186-X].
 37. S.Yu. Bulavenko, P.V. Melnik, M.G. Nakhodkin. Scanning tunneling microscopy images of the atoms in the corner holes on the Si(111)-(7×7) surface with bismuth-covered tips. *Surf. Sci.* **469**, 127 (2000) [DOI: 10.1016/S0039-6028(00)00798-6].
 38. S.Yu. Bulavenko, P.V. Melnik, M.G. Nakhodkin, A. Goriachko. Investigation of hydrogen interaction with the Si(111)-(7×7) surface by STM with Bi/W tips. *Surf. Sci.* **600**, 1185 (2006) [DOI: 10.1016/j.susc.2006.01.021].
 39. I.F. Koval, P.V. Melnik, N.G. Nakhodkin, M.Yu. Pyatnitsky, T.V. Afanasieva. Interaction of O₂ with the BiSi(001) system: from passivation to promoted oxidation. *Surf. Sci.* **384**, L844 (1997) [DOI: 10.1016/S0039-6028(97)00285-9].
 40. T.V. Afanasieva, S.Yu. Bulavenko, I.F. Koval, H.J.W. Zandvliet. Diffusion of Si and Ge dimers on Ge(001) surfaces. *J. Appl. Phys.* **93**, 1452 (2003) [DOI: 10.1063/1.1533107].
 41. I.P. Koval, Y.A. Len, M.G. Nakhodkin, M.O. Svishevs'kyi, M.Y. Yakovenko. Interaction of molecular oxygen with Si(001) surface covered with a chromium or titanium monolayer. *Ukr. J. Phys.* **60**, 46 (2015) [DOI: 10.15407/ujpe60.01.0046].
 42. M.G. Nakhodkin, M.I. Fedorchenko. Adsorption of Bi atoms on Ge(111)-c(2×8) surface. *Visn. Nats. Akad. Nauk Ukr. Ser. Fiz. Mat. Nauky* No. 4, 236 (2010) (in Ukrainian).
 43. M.Yu. Pyatnitskii, I.F. Koval', P.V. Mel'nik, N.G. Nakhodkin, T.V. Afanas'eva. Effects of adsorbed bismuth on Si(001) surface electronic states. *Theor. Exp. Chem.* **32**, No. 3, 148 (1996) [DOI: 10.1007/BF01373240].
 44. T.V. Afanasieva. Adsorption and dynamics of group IV, V atoms and molecular oxygen on semiconductor group IV (001) surfaces. *J. Phys.: Condens. Matter* **28**, 313001 (2016) [DOI: 10.1088/0953-8984/28/31/313001].
 45. N.G. Nakhodkin, T.V. Rodionova. The mechanism of secondary grain growth in polysilicon films. *J. Cryst. Growth* **171**, 50 (1997) [DOI: 10.1016/S0022-0248(96)00476-9].
 46. N.G. Nakhodkin, N.P. Kulish, T.V. Rodionova. Faceting of twin tips in polysilicon films. *J. Cryst. Growth* **381**, 65 (2013) [DOI: 10.1016/j.jcrysgro.2013.06.029].
 47. N.G. Nakhodkin, N.P. Kulish, P.M. Lytvyn, T.V. Rodionova. Features of special joints of grain boundaries in polysilicon films of equiaxial and dendritic structures. *Funct. Mater.* **13**, 305 (2006).
 48. M.G. Nakhodkin, M.I. Fedorchenko. Interaction of oxygen and gadolinium with Si(100)-2×1 surface. Formation of a system with 1-eV work function. *Ukr. J. Phys.* **60**, 97 (2015) [DOI: 10.15407/ujpe60.02.0097].
 49. *Faculty of Physics of I.I. Mechnikov National University of Odesa. 1865–2000: Collection of papers*. Edited by G.G. Chemeresyuk (Astroprint, 2001) (in Ukrainian).
 50. V.A. Smyntyna. *Molecular Electron Phenomena on the Semiconductor Surface: Selenide and Cadmium Sulfide Films* (Astroprint, 2008) (in Russian).
 51. V.A. Smyntyna. *Molecular Electron Phenomena on the Semiconductor Surface: Semiconductor Gas Sensors* (Astroprint, 2009) (in Russian).
 52. I.R. Yatsunskii, O.A. Kulinich, V.A. Smyntyna. *Influence of Oxidation on Defect Formation in Doped Silicon* (Lambert, 2011) (in Russian) [ISBN: 978-3-8465-4157-9].

53. V.A. Smyntyna, V.A. Borshchak, E.V. Britavskii, A.A. Karpenko. *Nonperfect heterojunctions for image sensors* (Odesa National University, 2014) (in Russian).
54. *Nonequilibrium Processes in Sensor Nanostructures*. Edited by V.A. Smyntyna. (Odesa National University, 2015) (in Russian).
55. V. Smyntyna. *Electron and Molecular Phenomena on the Surface of Semiconductors* (Nova Publishers, 2013).
56. V. Smyntyna. *Semiconductor Materials for Gas Sensors* (Nova Publishers, 2013).
57. V. Smyntyna, A. Tereshchenko. Metal oxide based biosensors for the detection of dangerous biological compounds? In *Nanomaterials for Security*. Edited by J. Bonča, S. Kruchinin (Springer, 2016), p. 281 [DOI: 10.1007/978-94-017-7593-9_22].
58. V.A. Smyntyna. *Physical and Chemical Phenomena on Solid Surface* (Astroprint, 2009) (in Ukrainian).
59. V.A. Smyntyna. *Course of General Physics* (Astroprint, 2012) (in Ukrainian).
60. V.A. Smyntyna. *Surface Phenomena in Semiconductors* (Odesa National University, 2016) (in Ukrainian).
61. R. Viter, I. Baleviciute, A. Abou Chaaya, L. Mikoliunaite, Z. Balevicius, A. Ramanavicius, A. Zalesska, V. Vataman, V. Smyntyna, Z. Gertnere, D. Erts, P. Miele, M. Bechelany. Optical properties of ultrathin Al₂O₃/ZnO nanolaminates. *Thin Solid Films* **594**, 96 (2015) [DOI: 10.1016/j.tsf.2015.10.018].
62. I. Iatsunskyi, M. Jancelewicz, G. Nowaczyka, M. Kempnińska, B. Peplińska, M. Jareka, K. Załęska, S. Jurga, V. Smyntyna. Atomic layer deposition TiO₂ coated porous silicon surface: Structural characterization and morphological features. *Thin Solid Films* **594**, 303 (2015) [DOI: 10.1016/j.tsf.2015.05.056].
63. R. Viter, Z. Balevicius, A. Abou Chaaya, I. Baleviciute, S. Tumenas, L. Mikoliunaite, A. Ramanavicius, Z. Gertnere, A. Zalesska, V. Vataman, V. Smyntyna, D. Erts, P. Miele, M. Bechelany. The influence of localized plasmons on the optical properties of Au/ZnO nanostructures. *J. Mater. Chem. C* **3**, 6815 (2015) [DOI: 10.1039/c5tc00964b].
64. I. Iatsunskyi, M. Pavlenko, R. Viter, M. Jancelewicz, G. Nowaczyk, I. Baleviciute, K. Zaleski, S. Jurga, A. Ramanavicius, V. Smyntyna. Tailoring the structural, optical, and photoluminescence properties of porous silicon/TiO₂ nanostructures. *J. Phys. Chem. C* **119**, 7164 (2015) [DOI: 10.1021/acs.jpcc.5b01670].
65. I. Iatsunskyi, M. Kempinski, M. Jancelewicz, K. Zaleski, S. Jurga, V. Smyntyna. Structural and XPS characterization of ALD Al₂O₃ coated porous silicon. *Vacuum* **113**, 52 (2015) [DOI: 10.1016/j.vacuum.2014.12.015].
66. R. Viter, A. Abou Chaaya, I. Iatsunskyi, G. Nowaczyk, K. Kovalevskis, D. Erts, P. Miele, V. Smyntyna, M. Bechelany. Tuning of ZnO 1D nanostructures by atomic layer deposition and electrospinning for optical gas sensor applications. *Nanotechnology* **26**, 105501 (2015) [DOI: 10.1088/0957-4484/26/10/105501].
67. V. Smyntyna. The chemisorption forms and the centre nature of oxygen chemisorption on the CdSe thin-film surfaces. *Nuovo Cimento* **63B**, 642 (1981).
68. Ya.I. Lepikh, I.A. Ivanchenko, L.M. Budiyaskaya. Uncooled p(Pb_{1-x}Sn_xSe)-n(CdSe) hetero-structure-based spectral range. *Semicond. Phys. Quant. Electron. Optoelectron.* **17**, 408 (2014).
69. Ya.I. Lepikh, I.A. Ivanchenko, L.M. Budiyaskaya. Strip-line-type photodetector based on the narrow-gap ternary compound Hg_{1-x}Cd_xTe for the far IR region. *J. Eng. Phys. Thermophys.* **86**, 242 (2013) [DOI: 10.1007/s10891-013-0825-z].

Received 23.08.16.

Translated from Ukrainian by O.I. Voitenko

В.Г. Литовченко

ПРО ДЕЯКІ ВАЖЛИВІ РЕЗУЛЬТАТИ
З ФІЗИКИ ПОВЕРХНІ НАПІВПРОВІДНИКІВ,
ОТРИМАНІ В УКРАЇНІ ЗА РОКИ
НЕЗАЛЕЖНОСТІ (1991–2016)

Резюме

В огляді наведено результати вибраних важливих результатів з фізики поверхні напівпровідників, отриманих в Україні за роки незалежності (1991–2016 роки). Після короткого історичного вступу викладено результати, систематизовані по основних наукових школах з фізики поверхні напівпровідників, а саме: школи фізики реальної поверхні (Василь Іванович Ляшенко), школи фізики межі поділу метал–напівпровідник (Віталій Ілларионович Стріха), школи атомарно-чистої поверхні напівпровідників (Микола Григорович Находкін), школи поверхнево-чутливих напівпровідникових сенсорів (В.В. Сердюк). Отримані результати в більшості базуються на нанорозмірних та квантоворозмірних структурах.