

Kryshchuk¹ M., Buryanov² A., Lykholdii² V., Ieshchenko¹ V.

1 - National Technical University of Ukraine «Kyiv Polytechnic Institute», Kyiv, Ukraine (mmi@kpi.ua)

2 - Bogomolets National Medical University, department of traumatology and orthopedics, Kyiv, Ukraine

COMPUTER MODELLING OF PATELLAR INSTABILITY IN ASSOCIATION WITH TROCHLEAR DYSPLASIA

Кришчук¹ Н.Г., д.т.н., проф., Бурьянов² А.А., д.м.н., проф., Лиходей² В.В., Ещенко¹ В.А.

1-НТУУ «Киевский политехнический институт», г. Киев, Украина; 2-Национальный медицинский университет им.

О.О.Богомольца, кафедра травматологии и ортопедии, г. Киев, Украина

ИМИТАЦИОННОЕ КОМПЬЮТЕРНОЕ МОДЕЛИРОВАНИЕ НЕСТАБИЛЬНОСТИ НАКОЛЕННИКА, КОТОРОЕ СОПРОВОЖДАЕТСЯ ДИСПЛАЗИЕЙ ОТРОСТКОВ БЕДРЕННОЙ КОСТИ

Abstract. Constructed a dynamic model of patellofemoral joint on human-based simulation computer model of a complex system of movement connected elastic and rigid bodies. Options patella biomechanical movement of bodies connected by joints defined by vector given angular velocity of rotation of the tibia. Patella speed depends on patellar spring-equivalents tension forces in connection, providing interaction force between the bodies of the simulation model. In this article, using of information technologies and application software a dynamic simulation model of patellofemoral joint is created. By calculation and theoretical determination of the angular, linear displacements of the patella, and the equivalent of von Mises stress in the patellar cartilage at knee flexion from 0° to 30° in normal and patellar instability, which is accompanied by trochlear dysplasia type A and B established that the concentrators at patellar instability are placed only on the lateral facet, regardless of the type of trochlear dysplasia. Type of dysplasia affects patellar displacement and distribution of von Mises equivalent stress in the patellar cartilage in normal and at instability.

The adequacy of the results of the numerical experiment tested by convergence controlled parameters values of stresses in the zones of maximum gradient.

Keywords: computer simulation, finite element method, patellar instability, trochlear dysplasia.

Introduction. Patellar stability and normal functioning of patellofemoral joint depends on clear interaction between soft tissue and bone stabilizers [1]. Tension in the patellar cartilage depends on knee flexion angle, intercondylar groove geometry and femoral condyles, state of medial and lateral stabilizers.

Effect of intercondylar groove geometry on patellar stability and soft tissue damage stabilizers have been investigated in 2D models [2, 3]. 3D model fully reflects the geometry of patellofemoral joint, the effect of dynamic soft tissue stabilizers *m.vastus medialis obliquus* on stress distribution in patellofemoral joint [5], and let simulate various pathological conditions and surgery [4, 8]. Simulated computer modeling using finite element method (FEM) to determine the stresses in the cartilage of the patella was applied to study patellofemoral pain syndrom [6, 7].

The question regarding impact of intercondylar groove geometry (of different types of trochlear dysplasia) on patellar stability, stress distribution in the patellofemoral joint cartilage and possible mechanisms of cartilage damage of the patellar with instability, accompanied by trochlear dysplasia remain open. In the literature there are no data to build dynamic simulation computer models of patellofemoral joint in normal and at patellar instability, accompanied by trochlear dysplasia (Dejour type A and type B). The reason are the mathematical difficulties encountered in the construction of numerical solutions for problems of biomechanics for deformed bodies connected with elements that move.

Objective. To carry out computational and theoretical study of linear and angular patella displacements and patterns of stresses distribution in the patellar cartilage in normal and at instability, accompanied by trochlear dysplasia of type A and type B by Dejour when bending the knee.

Materials and methods. The task is solved using the methods of cone-beam computer tomography for visual and quantitative evaluation of density and geometry parameters of the inhomogeneous bone structure of the knee joint, which are visualized, mechanics of solids, which elastically deformed, computational mathematics and information technology for simulation FEM the dynamics of patellar with instability, accompanied by dysplasia of the femoral condyles using CAD / CAE systems.

The object of study in this paper is selected the dynamic simulation computer model of biomechanical knee (Fig. 1) in normal and patellar instability conditions that is created from five volumetrical structural elements: three solids (patella, femur and tibia bones) that are not deformed, two highly compressible bodies (cartilage patella and femoral condyles) that can be elastically deformed and five spring equivalents ligaments of patella and quadriceps femoris, providing interaction force between bodies.

Three-dimensional volumes of the femur and tibia, patella and articular cartilage, based on actual CT knee with two types of dysplasia femoral condyles (type A and B) and presented as paired bodies amounts of data in applications MIMICS and Solidworks [11,12]. Cartilage patella and femur form in imitating model joint shared contact area that varies with flexion / extension of the knee.

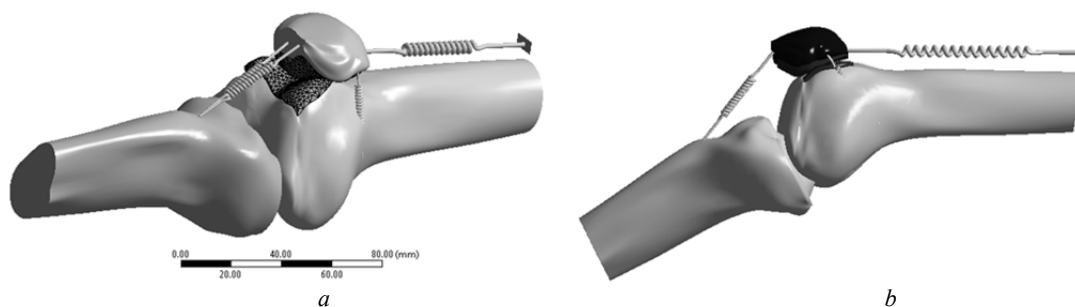

Fig. 1. A simulation model of biomechanical knee joint with an arrangement of connected elements in the initial state (a) and when it is bent at 30 degrees (b)

The quantities of each spring stiffness defined according to [3] for experimental research gnatodynamometria for muscles and ligaments patella (Table 1). Topology their placement in imitating model patellar determined by biomechanical characteristics of the knee joint of man and the preliminary results of the numerical experiment. Mechanical properties of articular cartilage tissue and ligaments selected according to the papers [1, 2] and are given in Table 1.

Table 1

Mechanical properties of ligaments, cartilage and quadriceps

	Young's modulus, MPa	Poisson's ratio	Stiffness N / mm
Articular cartilage	2.077 – 0.518[2]	0.465 – 0.326[2]	--
Patellar ligament	-	-	97 [3]
The medial and lateral patella femoral ligament (normal state)	-	-	7 [3]
Patelofemoralna medial ligament (instability)	-	-	0.3[3]
Quadriceps	-	-	1[3]

To study the dynamics of movement patella when bent tibia relative to the fixed femur in imitating model inserted joint hinges with appropriate degrees of freedom. Patellar instability modeled by reducing rigidity of medial patelofemoralliagment to 0.3 N/mm [3]. Discretized models of cartilage and patella femoral conducted in programming complex Ansys 12.1 [13] using the finite tetrahedronelements in the number of 2839 and 4180 respectively for joint models of type A and type B. They required amount determined iterative. The adequacy of the results of the numerical experiment examined convergence controlled parameters values of stresses and strains in the zones of maximum gradient.

In nonlinear dynamic equations that describe the mechanical state of the united contacting solid and deformed moving bodies, using basic classical balance ratio of continuum mechanics in the form of conservation laws. Transfer equation, dynamic equilibrium, compatibility of deformation constitutive relation for small deformations in the form of Cauchy and elastic stresses by Hooke's law, boundary and initial conditions and value in the form of restrictions on power and kinematic conditions of contact interaction of deformed bodies of continuum mechanics underlying the developed mathematical model.

To describe the dynamics of connected bodies of biomechanical system chosen three-dimensional Euclidean space with different coordinate systems and classical times. As a basis in the space of a motionless observer used a three-dimensional orthogonal system of Cartesian coordinates. It was taken that at the initial time t_0 connected undeformed body and occupy the spatial region of volume V^0 and initial configuration Ω_c^0 and respectively V^c for the known current configuration Ω_c at the time t . Options patella biomechanical movement of bodies connected by joints defined by vector of given angular velocity $\varphi^c(t)$ of rotation of the tibia on the pole O . Speed depends on patellar tensionforces of spring ligament patella equivalents, providing interaction force between the bodies of the simulation model.

In order to simplify the analysis of the relative motion of particles elastically deformable environment patellar cartilage have introduced a number of hypotheses. It was taken that the interval of time that precedes $t_1 > t_0$, is movement of particles undeformed environment tibia and tightly interconnected cartilage and patella. At the current small time interval $[t_1, t_2]$ the motion of particles environment patellar cartilage presented by superposition of finite displacements of rolling undeformed environment and displacement caused by its deformation.

The move trajectory of the center of mass patella of given shape determines the geometric profile of surfaces coupling cartilage and patella femoral condyles, kinematic and force conditions on the surface of the contacting deformed bodies cartilage patella and femur, the current distribution of forces tension springs model thigh muscles and ligaments in flexion knee at a given angle.

Results. In this clinical study we first proposed and applied the dynamic simulation computer model of patellofemoral joint for the study of stress distribution in patellar cartilage in normal and at instability in different types of trochlear dysplasia (A, B by Dejour). Patellar movement and stress distribution in the cartilage on the lateral and medial facet is determined by coherent interaction of lateral and medial stabilizers, quadriceps femoris and own patellar ligament as well as patellar geometry and intercondylar groove. Patellar instability is characterized by damage of the medial patellofemoral ligament [1], which is the primary soft tissue stabilizer of patella at first 30° flexion of the knee joint. Violation of the integrity of the medial stabilizer affects the patellar congruence of intercondylar groove and alters the stress distribution in patellar cartilage.

Model A₁ (norm) is characterized by a gradual increase in tension in the patellar cartilage to the achievement of a maximum of 2.30 MPa at an angle of knee flexion 30° (Fig. 2). Tension concentrators are divided into medial and lateral patellar facet dominated by lateral facet.

When bending the knee from 0° to 30° a medial lateral displacement of the medial patellar size 1.6 mm takes place. Lateral patellar tilt angle when bending the knee at 30° was 10°. Biomechanics of patellofemoral joint in normal while bending the tibia from 0° to 30° is characterized by medial patellar displacement, due to spatial orientation of intercondylar groove of the femur.

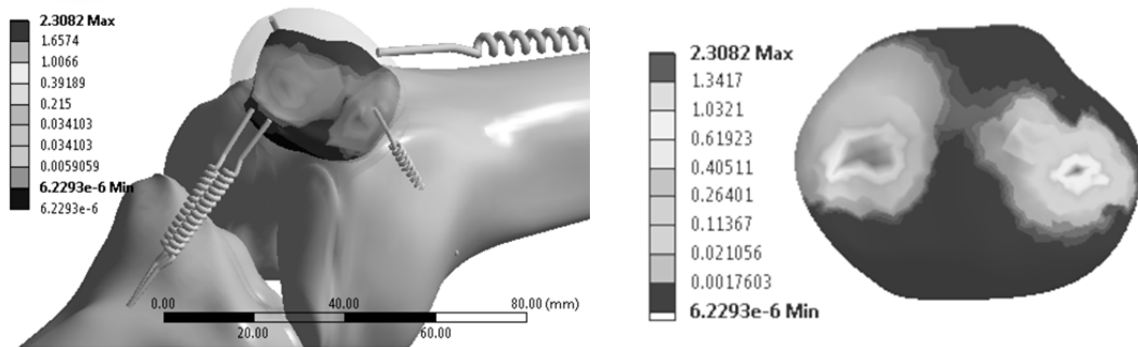

Fig. 2. Distribution by Mises equivalent stress in MPa patellar cartilage normally at 30° knee flexion, the trochlear dysplasia type A

Model A₂ (instability) is characterized by a gradual increase in tension in the patellar cartilage when bending the knee between 0° to 20° and the appearance of fluctuations in their amplitudes in the range of angles of inclination of the tibia from 20° to 30°, with the advent of maximum stress 2.09 MPa respectively, at 24° and 29°. Stress concentrator at instability is located on the lateral patellar facet and progressively decreases depending on the angle of flexion compared with the normal (Fig. 3). At 30° flexion of the knee joint by Mises equivalent stress in the patellar cartilage was 1.93 MPa.

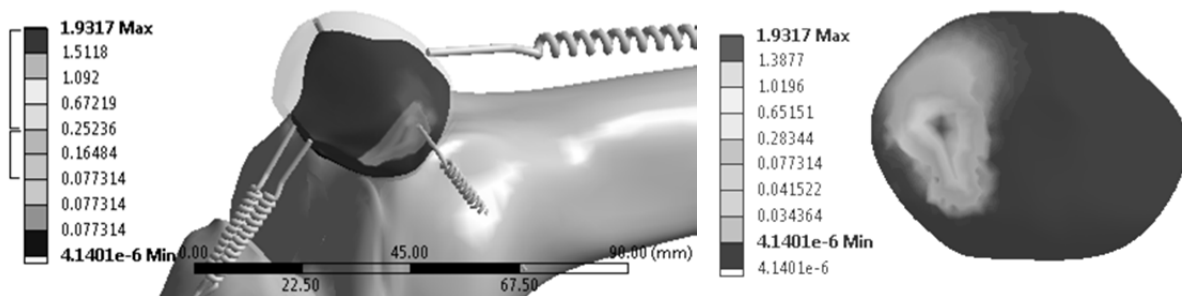

Fig. 3. Distribution of Mises equivalent stresses in MPa cartilage patellar instability at 30° knee flexion

At instability, accompanied by trochlear dysplasia type A, bending the knee from 0° to 30° lateral transverse patellar displacement of 4.1 mm was noted. The angle of patella when bending knee at 30° was 25°.

When comparing the stress in the models A₁ (normal) and A₂ (instability) we defined the tendency to increase tension in the patellar cartilage at instability in the knee flexion angles from 0° to 25° (Fig. 4) and the emergence of tension concentrator only on lateral facet at instability. Tension in the patellar cartilage at instability, accompanied by trochlear dysplasia type A, increased by 116% compared to the norm at an angle of flexion 10°, by 105% at an angle of flexion 20° (Table 2).

However, at the corner of knee flexion 30° tension in patellar cartilage in normal was 2.3 MPa, while at instability - 1.9 MPa, which is 16% less than normal (Table 2). Reducing tension in the patellar cartilage at instability, accompanied by condyle dysplasia type A, 30° flexion of the knee can be explained by progressive lateral patellar displacement that characterizes the tendency to dislocation of the patella (complete mismatch of the articular surfaces of patella and femoral condyles). Difference in patellar transverse displacement between norm A₁ and instability A₂ was 5.7 mm. With instability A₂ the angle of lateral patellar tilt increased by 15° compared to the norm.

The findings indicate impact of intercondylar groove on the position and stability of patellar in normal. Patellar lateralization caused by the damage of the medial patellofemoral ligament at instability disturbs congruence in patellofemoral joint and increases tension on the lateral facet during interaction between intercondylar groove and patella.

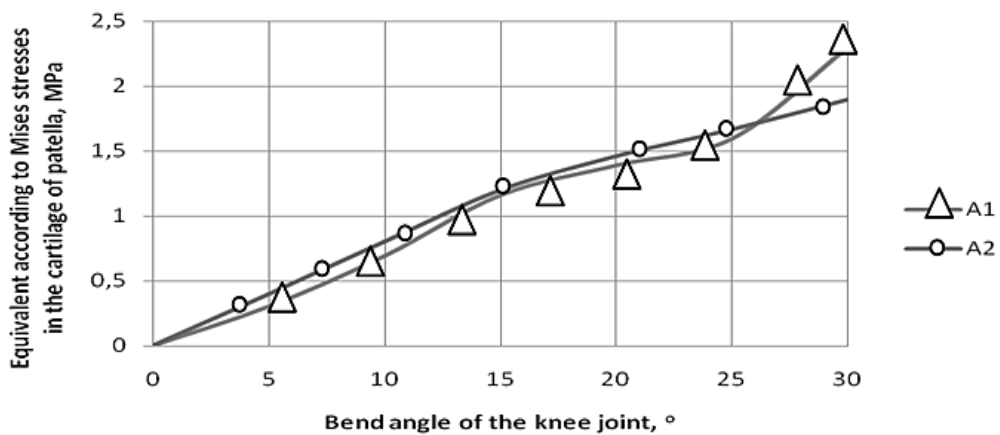

Fig. 4. Dependence of equivalent according to Mises stresses in the cartilage of patella on bend angle of the knee joint in normal and at patellar instability, accompanied by trochlear dysplasia type A

Patellar instability, accompanied by trochlear dysplasia type A, characterized by increased tension on the lateral facet in patellar cartilage and angular and linear displacements of patella in relation to the femur.

The tension on the patellar cartilage in normal (B1) at condyle dysplasia type B is characterized by the appearance of cyclical fluctuations and increase with the achievement of maximum 2.30 MPa at an angle of knee flexion 22°. Concentrators of tension are divided into medial and lateral patellar facet dominated by lateral facet. Tension at an angle of 30° is 1.80 MPa with localization of tension concentrator on lateral facet (Fig. 5).

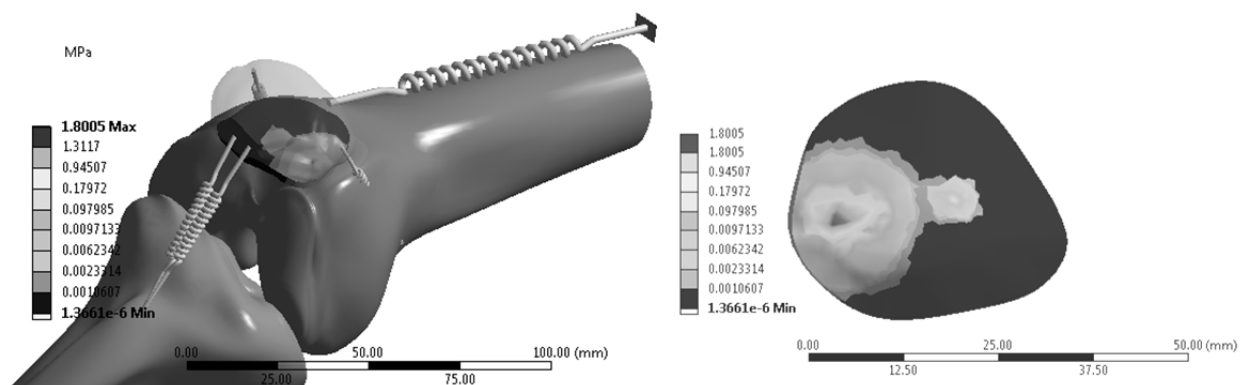

Fig. 5. Distribution of equivalent by Mises stresses, MPa of patellar cartilage is in norm, at 30° knee flexion, at the trochlear dysplasia type B

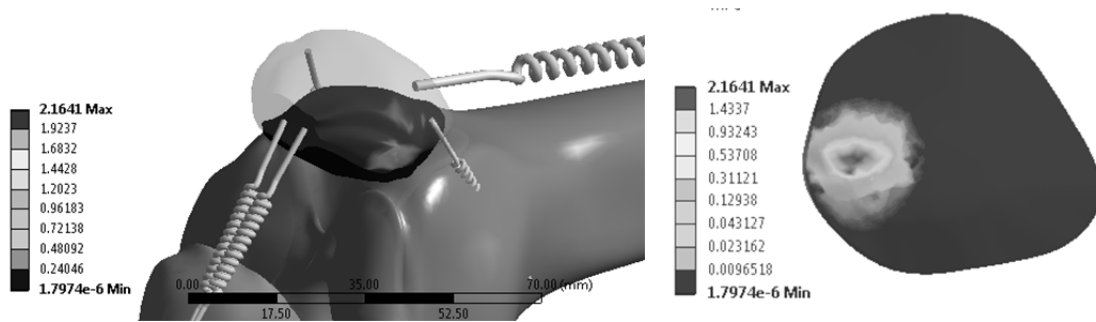

Fig. 6. Distribution of equivalent by Mises stresses, MPa of patellar cartilage is at instability, at 30° knee flexion, at the trochlear dysplasia type B

When bending the knee from 0° to 30° medial lateral patellar displacement of -4.7 mm was noted. The angle of patella when bending knee at 30° was 12°.

The tension on the patellar cartilage at instability, accompanied by trochlear dysplasia type B, is characterized by the increase from 0° to 28° with the advent of peak vibrations at 4° (0,88 MPa), 22° (1,80 MPa) and 28° (2,22 MPa) bending, with the advent of maximum stress 2.22 MPa at 28° (Fig. 7). The hub tension appears only on the lateral patellar facet

When bending the knee from 0° to 30° medial lateral patellar displacement of -3.4 mm was noted. The difference in displacement between the rate of B₁ and B₂ instability was 1.3 mm. The angle of patella when bending knee at 30° was 19°. The angle of inclination of the lateral patellar at B₂ instability increased by 7° comparing to the norm B₁.

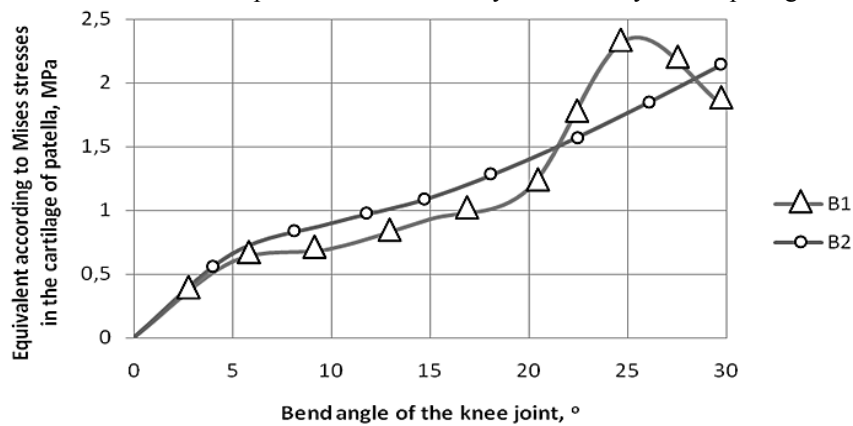

Fig. 7. Dependence of stresses in the cartilage of patella on bend angle of the knee joint in normal and at patellar instability, accompanied by trochlear dysplasia type B

When comparing the model B₁ (normal) to B₂ (instability) it was defined the tendency to increase the tension in patellar cartilage at instability in the knee flexion angles from 5° to 22° and 28° to 30° (Fig. 7), and the emergence of tension concentrator on lateral facet at patellar instability (Fig. 6).

The tension in the patellar cartilage at instability, accompanied by dysplasia of the femoral condyles type B, increased by 26% compared with the norm at an angle of flexion 10°, by 20% at an angle of flexion 20°, by 23% at an angle of flexion 30° (Table 2).

Table 2

Distribution of equivalent by Mises stresses in the patellar cartilage models of type A and B, depending on the angle of knee flexion

Bend angle, degrees	Dysplasia type A			Dysplasia type B		
	A ₁ , norm	A ₂ , instability		B ₁ , norm	B ₂ , instability	
	Tension in the patellar cartilage, MPa	Tension in the patellar cartilage, MPa	Stress change in patella cartilage compared with norm A ₁ , %	Tension in the patellar cartilage, MPa	Tension in the patellar cartilage, MPa	Stress change in patella cartilage compared with norm B ₁ , %
10	0,69	0,80	116	0,70	0,88	126
20	1,39	1,46	105	1,17	1,40	120
30	2,30	1,93	84	1,80	2,22	123

These data indicate that trochlear dysplasia type B does not provide the necessary stability and congruence of patellofemoral joint at 30° flexion of the knee joint. The stability of the patella at trochlear dysplasia type B was more dependent on the state of the medial patellofemoral ligament than at trochlear dysplasia type A. Damage of the medial patellofemoral ligament at dysplasia type B causes more stress in cartilage patellar than at instability when accompanied by dysplasia type A (Table 2).

Patellar instability, accompanied by trochlear dysplasia type A is characterized by more angular and linear displacements than with patellar dysplasia type B. This study revealed features of kinematics at patellar instability, manifested by a tendency to increase the tension in the articular cartilage or in increasing lateral patellar displacement depending on the type of dysplasia.

The work done when bending the knee at patella instability is realized mainly into the increase in tension in the cartilage in the conditions of its elastic deformation or lateral patellar displacement.

Trochlear dysplasia of Type B is characterized by a smaller angle of inclination of lateral condyle femur and lower angle of intercondylar groove, and therefore does not provide the necessary correct position and stability of the patella. The more severe the dysplasia, the more important is the role of the medial patellofemoral ligament in ensuring patella stability.

Conclusions

1. Construction using finite element simulation computer models of patellofemoral joint in normal and pathology at different bending angles lets determine the state of all components of dynamics of the created biomechanical system at load, as well as prove approaches of correction patellar instability at different types of trochlear dysplasia.
2. The main pathogenetic factor in patellar cartilage damage at instability is to increase the tension in the patellar cartilage when bending the knee and the appearance of stress concentrators only on lateral facet regardless the type of dysplasia.
3. Type of trochlear dysplasia affects the stability of patella, angular and linear displacement, stress distribution in patellar cartilage and cartilage damage of patellofemoral joint, and hence the development of patellofemoral osteoarthritis.
4. Direct correlation between the severity of dysplasia and stabilizing role of patellofemoral medial ligament has been established. Structural and functional insufficiency of condyle femoral is compensated, to some extent, by soft tissue stabilizers.
5. Instability of patellar with dysplasia type A is characterized by large angular rotation at 25° and linear 5.7 mm displacements of its center of mass with a slight increase in tension in the cartilage at 16% occurring in the range of knee flexion from 10° to 20°.
6. Patellar instability, accompanied by dysplasia type B, is characterized by an increase of 26% strain in its cartilage during joint flexion angles between 0° and 30°, with slight corner bends at 7° and 1.3 mm linear bias of its center of mass.
7. Stability of patellar and distribution in cartilage stress depends not only on damage of the medial patellofemoral ligament, but also on the type of trochlear dysplasia.

***Анотація.** Створено динамічну модель пателофemorального суглоба. Проведено визначення кутових та лінійних переміщень наколінка, а також еквівалентних за Мізесом напружень в хрящі наколінка при згинанні колінного суглоба від 0° до 30° в нормі та при нестабільності наколінка, що супроводжується дисплазією виростків стегнової кістки тип А та В. Встановлено, що при нестабільності наколінка концентратори напружень розташовуються лише на латеральній фасетці незалежно від типу дисплазії. Тип дисплазії впливає на кутові та лінійні переміщення наколінка, а також розподіл еквівалентних за Мізесом напружень в хрящі наколінка в нормі та при нестабільності.*

***Ключові слова:** комп'ютерне моделювання, метод скінченних елементів, нестабільність наколінка, дисплазія виростків стегна.*

***Анотация.** В данной работе на современном уровне развития информационных технологий и прикладного программного обеспечения создана динамическая имитационная модель пателофemorального сустава. Проведено расчетно-теоретическое определение угловых, линейных смещений надколенника, а также эквивалентных за Мизесом напряжений в хряще надколенника при сгибании коленного сустава от 0° до 30° в норме и при нестабильности, что сопровождается дисплазией мыщелков бедра тип А и В. Установлено, что при нестабильности надколенника концентраторы напряжений размещаются только на латеральной фасетке независимо от типа дисплазии. Тип дисплазии влияет на смещение надколенника и распределение эквивалентных за Мизесом напряжений в хряще надколенника в норме и при нестабильности.*

***Ключевые слова:** компьютерное моделирование, метод конечных элементов, нестабильность надколенника, дисплазия мыщелков бедра.*

1. [Amis A.A.](#) Current concepts on anatomy and biomechanics of patellar stability. Sports Med Arthrosc. 2007 Jun; 15(2):48-56.
2. [Jafaril A, Farahmand F, Meghdari A.](#): The effects of trochlear groove geometry on patellofemoral joint stability-a computer model study. Proc Inst Mech Eng H. 2008 Jan ; 222(1):75-88.
3. [Jafari A, Farahmand F, Meghdari A.](#) A rigid body spring model to investigate the lateral shift - restraining force behavior of the patella. Conf Proc IEEE Eng Med Biol Soc. 2007 ; 2007:4679-82.
4. [Elias JJ, Cosgarea AJ.](#) Sports Med Arthrosc. 2007 Jun; 15(2):89-94. Computational modeling: an alternative approach for investigating patellofemoral mechanics.
5. [Elias, J.J., Kilambi S. and Cosgarea A.J.](#) 2010. Computational Assessment of the Influence of Vastus Medialis Obliquus Function on Patellofemoral Pressures: Model evaluation. Journal of Biomechanics. 43, pp.612-617.
6. [Besier T.F, Gold G.E, Beaupré G.S, Delp S.L.](#) A modeling framework to estimate patellofemoral joint cartilage stress in vivo. Med Sci Sports Exerc. 2005 Nov ; 37(11):1924-30.
7. [Farrokhi S, Keyak J.H, Powers C.M.](#) [Individuals with patellofemoralpain exhibit greater patellofemoral joint stress: a finiteelement analysis study.](#) Osteoarthritis Cartilage. 2011 Mar; 19(3):287-94. Epub 2010 Dec 21.
8. [Fitzpatrick C.K, Baldwin M.A, Rullkoetter P.J.](#) Computationally efficient finite element evaluation of natural patellofemoral mechanics. J Biomech Eng. 2010 Dec ; 132(12):121013.
9. [Dejour D, Le Coultre B.](#) Osteotomies in patellofemoral instabilities. Sports Med Arthrosc 2007; 15(1):39-46.
10. [Dejour H, Walch G, Neyret Ph, Adeleine P.](#) Dysplasia of the femoral trochlea. Rev Chir Orthop Reparatrice Appar Mot 1990;76:45-54.
11. <http://www.materialise.kiev.ua>
12. <http://www.solidworks.com>
13. [ANSYS Workbench. User's Guide. Release 12.1, 2009.-124p.](#)

REFERENCES

1. [Amis A.A.](#) Current concepts on anatomy and biomechanics of patellar stability. Sports Med Arthrosc. 2007 Jun; 15(2):48-56.
2. [Jafaril A, Farahmand F, Meghdari A.](#): The effects of trochlear groove geometry on patellofemoral joint stability-a computer model study. Proc Inst Mech Eng H. 2008 Jan ; 222(1):75-88.
3. [Jafari A, Farahmand F, Meghdari A.](#) A rigid body spring model to investigate the lateral shift - restraining force behavior of the patella. Conf Proc IEEE Eng Med Biol Soc. 2007 ; 2007:4679-82.
4. [Elias JJ, Cosgarea AJ.](#) Sports Med Arthrosc. 2007 Jun; 15(2):89-94. Computational modeling: an alternative approach for investigating patellofemoral mechanics.
5. [Elias, J.J., Kilambi S. and Cosgarea A.J.](#) 2010. Computational Assessment of the Influence of Vastus Medialis Obliquus Function on Patellofemoral Pressures: Model evaluation. Journal of Biomechanics. 43, pp.612-617.
6. [Besier T.F, Gold G.E, Beaupré G.S, Delp S.L.](#) A modeling framework to estimate patellofemoral joint cartilage stress in vivo. Med Sci Sports Exerc. 2005 Nov ; 37(11):1924-30.
7. [Farrokhi S, Keyak J.H, Powers C.M.](#) [Individuals with patellofemoralpain exhibit greater patellofemoral joint stress: a finiteelement analysis study.](#) Osteoarthritis Cartilage. 2011 Mar; 19(3):287-94. Epub 2010 Dec 21.
8. [Fitzpatrick C.K, Baldwin M.A, Rullkoetter P.J.](#) Computationally efficient finite element evaluation of natural patellofemoral mechanics. J Biomech Eng. 2010 Dec ; 132(12):121013.
9. [Dejour D, Le Coultre B.](#) Osteotomies in patellofemoral instabilities. Sports Med Arthrosc 2007; 15(1):39-46.
10. [Dejour H, Walch G, Neyret Ph, Adeleine P.](#) Dysplasia of the femoral trochlea. Rev Chir Orthop Reparatrice Appar Mot 1990;76:45-54.
11. <http://www.materialise.kiev.ua>
12. <http://www.solidworks.com>
13. [ANSYS Workbench. User's Guide. Release 12.1, 2009.-124p.](#)