

УДК 621.373

**LOW COST LOW PHASE NOISE PLL CONTROLLED PUSH-PUSH
VCOS IN K- AND KA-BANDS, STABILIZED BY CAVITY
RESONATOR¹**

Tsvelykh I. S.^{1,2}; Kotserzhynskiy B. O.², Doctor of Engineering, Professor

¹*ALTEN GmbH, Munich, Germany, itsvelykh@de.alten.com*

²*National Technical University of Ukraine*

«Kyiv Polytechnic Institute», Kyiv, Ukraine

**ДВОТАКТНІ ГКН К- ТА КА-ДІАПАЗОНІВ НА ОСНОВІ ОБ'ЄМНОГО
РЕЗОНАТОРА, СТАБІЛІЗОВАНІ ФАПЧ, З МАЛИМ РІВНЕМ ФАЗОВОГО
ШУМУ ТА НИЗЬКОЮ ВАРТІСТЮ**

Цвєлих І. С., Коцєржїнський Б. О.,

ALTEN GmbH, Мюнхєн, Німєччина

НТУУ «КПІ», Київ, Україна

Introduction

Phase noise of microwave and millimeter wave range oscillators is one of the most critical parameters that limit the performance of cutting edge communication systems. Low level of integrated phase error of oscillator signal is a key requirement for high order complex modulation schemes that enable channels with high spectral efficiency. Low phase noise performance of microwave oscillators is commonly achieved by using dielectric resonators (DR), which have quality factors reaching 10000 and more in X-, Ku- bands [1, 2]. However, this solution has disadvantages such as increased cost, necessity of resonator tuning and increased size due to introduction of a metal shielding needed to reduce radiation loss. Metal cavity resonators can be used as an alternative to DR: they have comparable quality factor values; are suitable for cost efficient design and are known for similar phase noise performance [3].

Analysis of various design approaches to developing a low cost and efficient signal source in microwave and millimeter wave ranges shows outstanding performance of push-push oscillators [4, 5]. Push-push oscillator design approach, first published in [6], is known for several advantages over a classic fundamental frequency oscillator. Two of its suboscillators generate signals that are rich in harmonics and combined power of their second harmonics is used as an output signal. It allows extending the frequency operation range of an active device beyond its transition frequency f_T and maximum oscillation frequency f_{MAX} [7]. In contrast to fundamental frequency oscillator, push-push design implements a resonator which operates at twice lower frequency where its quality factor is

¹ <http://radap.kpi.ua/radiotechnique/article/view/1225>

generally higher. Push-push oscillators typically occupy less space and provide better phase noise compared to frequency multipliers [8].

This article describes low phase noise PLL stabilized push-push VCOs with traditional second harmonic output at 24 GHz and with third harmonic output at 36 GHz (concept proposed in [9]). Oscillators implement a low cost rectangular cavity resonator design described in [10] and complemented in the present work.

Resonant system design

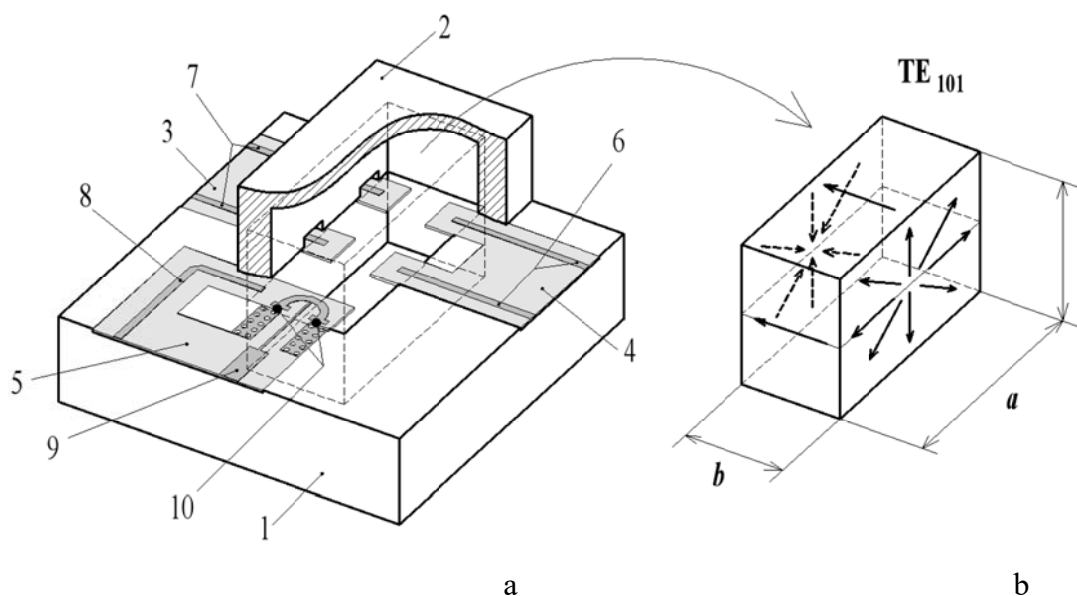

Fig. 1. Resonant system of cavity stabilized VCO (a) with surface currents of TE_{101} mode shown (b).

Base metal plate 1 and cover 2 form a resonator cavity. Substrates 3, 4 and 5 contain coupling probes with the VCO circuitry. Due to symmetrical dissection of the resonator across its length l , surface currents of TE_{101} mode (fig. 1, (b)) flow in parallel to the cutting plane and thus are not affected by the junction resistance between the base 1 and the cover 2. This allows excluding the impact of junction resistance on the resonator's quality factor. The resonant system of the proposed voltage controlled push-push oscillators consists of a rectangular waveguide cavity resonator with $a \times b$ cross section, cut into two halves across its longitudinal dimension l as shown in fig. 1. Hollows in

Dimensions were chosen to obtain resonance frequency of operating oscillation mode TE_{101} at 12GHz: $a=23\text{mm}$, $b=10\text{mm}$, $l=14,8\text{mm}$. Unloaded quality factor calculation by using an expression based on general solutions to Maxwell's equations, and by using Finite Integration Technique in CST Microwave Studio 3D EM simulation tool provide a close match of 5844 and 5895 respectively [10]. However, both calculations do not take into account surface roughness effects.

Two suboscillators of push-push VCOs are coupled with the cavity via pairs of microstrip probes 6 and 7. Probe 8 is intended for coupling with the PLL syn-

thesizer input. Probe 9 is connected to the two varactors 10 and provides their coupling with resonance TE_{101} mode. It serves as a DC bias voltage line to enable frequency tuning. Position of the probes 6 and 7 at the opposite sides of the broad walls of rectangular resonator provides 180° phase shift between their signals, which is necessary for push-push mode of operation. The proposed structure allows incorporating low cost and high-Q cavity resonator with a planar hybrid-integrated oscillator substrate in a quasi-planar design.

VCO design

Substrates of the microstrip oscillators are made of glass microfiber reinforced PTFE composite laminate RT5880 Duroid, metal base and cover are

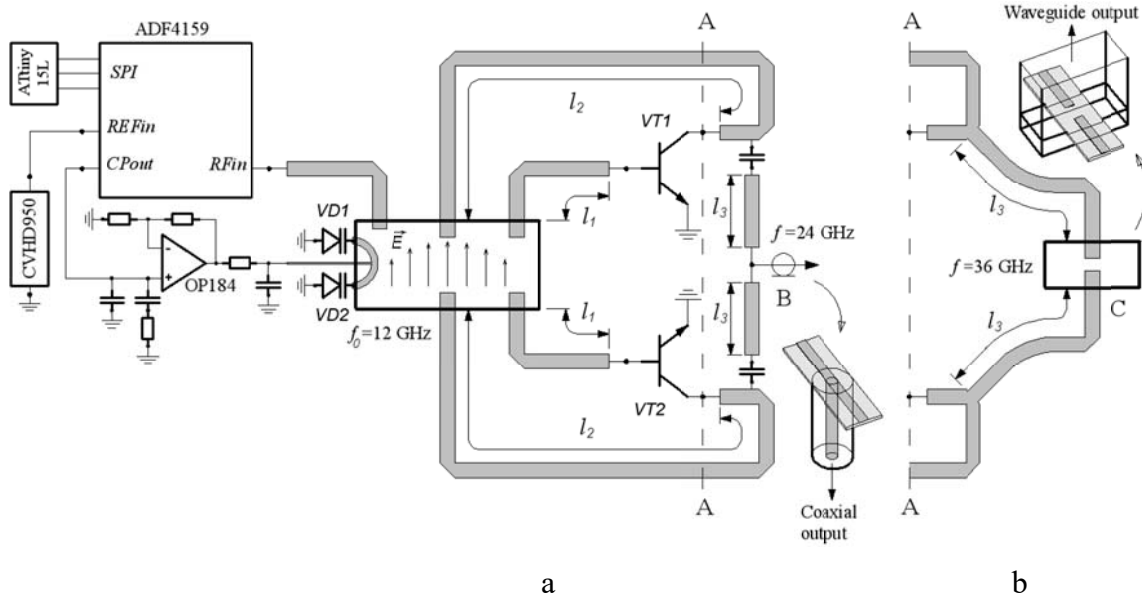

Fig. 2. Topology and key elements of PLL controlled push-push VCOs with second harmonic output at 24 GHz (a) and third harmonic output at 36 GHz (b).

made of D16T aluminum alloy (ENAW-2024). The topology and key elements of the proposed PLL stabilized VCOs are shown in fig. 2. Grey stripes depict microstrip lines on substrates 3, 4 and 5. Power supply circuitry and transistors' active bias networks are not shown for the sake of simplicity. VCO is based on a push-push architecture, it has two suboscillators based on a feedback loop circuit with shared frequency determining network formed by the rectangular cavity resonator. Discrete bipolar transistors $VT1$ and $VT2$ are used as gain blocks. $VT1$ and $VT2$ transistors are heterojunction bipolar devices BFU730F based on Si-Ge:C technology characterized by transition frequency of 110 GHz. Transistors of this type are known for excellent noise performance compared to other technologies [4, 11, 12].

VCOs are implemented in two versions, which are defined by an output power combining network connected at the cutting plane A-A. The version shown in fig. 2, (a) is a push-push oscillator with traditional second harmonic

output at 24 GHz. Line length of its suboscillator feedback loops $l_1 + l_2$ is calculated out of sustained oscillation conditions at small signal and further optimized in nonlinear harmonic balance simulation. Coupling of the probes with the resonator is selected to provide the relation between loaded and unloaded quality factor of $Q_L/Q_U=1/2$ for minimum phase noise level [13]. Oscillations start with increase in amplitude of noise fluctuations in active devices until they become limited by gain compression mechanism. Under large signal conditions transistor gain drops and eventually becomes equal to overall loss of feedback loop that leads to a steady state oscillation mode with stable signal amplitude and frequency. Spectrum of $VT1$ and $VT2$ collector voltages is rich in harmonics due to nonlinear nature of gain compression, assuming that suboscillators are perfectly equal it can be written as:

$$s_{VT1}(t) = \sum_{n=0}^{\infty} a_n \cdot \sin(n\omega_0 t + \varphi_n), \quad (1)$$

$$s_{VT2}(t) = \sum_{n=0}^{\infty} a_n \cdot \sin(n\omega_0 t + \varphi_n + \Delta\varphi_n). \quad (2)$$

Owing to the antiphase operation of suboscillators, the phase differences of the harmonic components of the two signals are given by

$$\Delta\varphi_n = n\pi. \quad (3)$$

By adding together $s_{VT1}(t)$ and $s_{VT2}(t)$ signals, a cancelation of odd harmonics (including fundamental) and increase of even harmonics levels is achieved:

$$s_{OUT}(t) = s_{VT1}(t) + s_{VT2}(t) = \sum_{n=2,4,\dots}^{\infty} 2 \cdot a_n \cdot \sin(n\omega_0 t + \varphi_n). \quad (4)$$

Power combiner network is represented by two coupling capacitors, transmission lines l_3 and coaxial output line B . Due to the odd mode of oscillations at fundamental frequency the point of lines l_3 and B connection is a virtual ground. By selecting its length of $\lambda_0/4$ open-ended impedance is transformed to the points of connection to suboscillators' loops. Thus, the load and suboscillators become isolated at fundamental frequency. Second harmonic in (4) concentrates the most of signal energy and is used as the output signal.

In contrast to traditional push-push approach with second harmonic output, the 36 GHz VCO version implements a third harmonic output concept proposed in [9]. By introducing power combining network, which performs an antiphase addition, levels of odd harmonics of output signal can be increased while even harmonics cancelled out:

$$s_{OUT}(t) = s_{VT1}(t) - s_{VT2}(t) = \sum_{n=1,3,\dots}^{\infty} 2 \cdot a_n \cdot \sin(n\omega_0 t + \varphi_n). \quad (5)$$

This enables the use of third harmonic of fundamental frequency as an output signal. Antiphase power combiner is implemented as a differential mi-

crostrip-to-waveguide transition C with a backshort in a base metal plate. It is connected at the cutting plane A-A (fig. 2, (b)). Output microstrip lines l_3 are connected to the probes of the transition. Given the 180° of phase shift between the signals in the lines l_3 , a TE_{10} mode is excited in the output waveguide of 7.2×3.4 mm cross section (EIA WR28). 3D EM simulation in CST Microwave Studio shows VSWR of the waveguide port of the transition of 1,15 at 36 GHz and less than 1,5 in the range of 33 – 40 GHz. The length of output lines l_3 is close to $\lambda_0/2$ at fundamental frequency in order to provide an open ended impedance at the points of connection with suboscillators' loops. Thus, a strong isolation between the load and the resonant system is achieved at fundamental frequency and is further improved by output waveguide since 12 GHz is well below 20,8 GHz cutoff for TE_{10} in 7.2×3.4 mm waveguide.

The proposed design of third harmonic output VCO provides several advantages compared to traditional push-push approach: three-fold increase in output frequency compared to two-fold increase of conventional push-push design; stronger isolation at below-cutoff fundamental frequency; additional filtering of higher order harmonics due to a bandpass frequency response of the microstrip to waveguide transition. Compared to triple-push approach, the proposed one occupies less space by using two suboscillators instead of three of a traditional triple-push design [14], smaller number of active devices lead to a better balancing of suboscillators.

To address the issue of frequency stability over temperature, a varactor tuning network was added to the designs. A silicon beam-lead hyper-abrupt varactor diodes were used for frequency tuning (marked as $I0$ on fig. 1 and $VD1$, $VD2$ on fig. 2). Diodes have high capacitance ratio of 12,4 with a capacitance range of 1,73 - 0,139 pF and reverse voltage of 0 – 20 V. Varactors are coupled with TE_{101} mode of the resonator by means of U-shaped strip line loop. A narrow-band tuning with low coupling was implemented for lower phase noise degradation (tuning performance is shown in the measurement results section). In the left part of fig. 2 the PLL with active loop filter based on ADF4159 frequency synthesizer is shown. An ultra low noise CVHD-950 reference crystal oscillator at 50 MHz is used to stabilize the frequency drift of the VCOs over temperature.

Phase noise and spectrum components of oscillator signals of the free running push-push oscillator without varactor tuning was simulated using harmonic balance method in Keysight ADS design automation software. The Mextram nonlinear bipolar transistor model [15] of BFU730F was used to properly take into account the device noise sources. The resonator model was imported into ADS as S-parameters block – a result of 3D EM simulation in CST Microwave Studio.

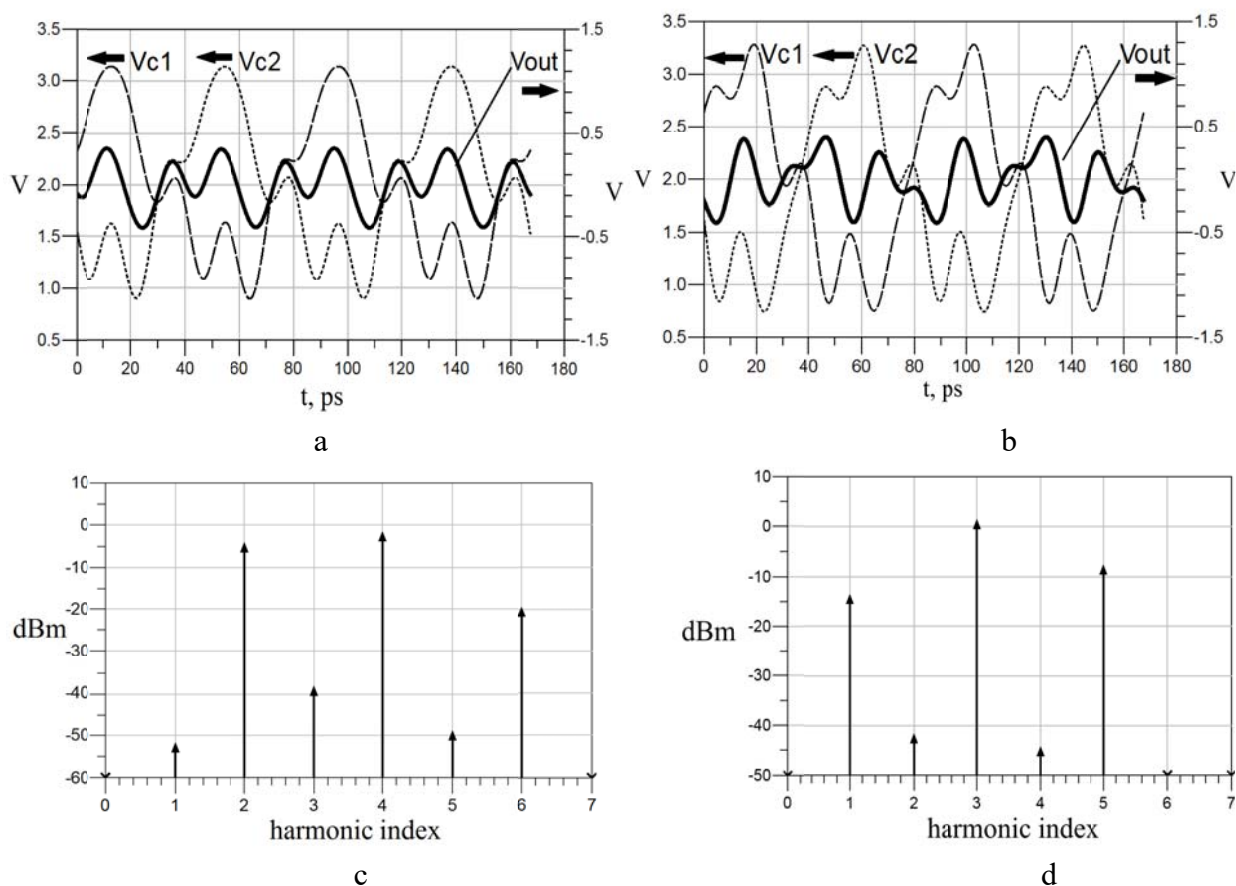

Fig. 3. Simulated collector voltages V_{c1} , V_{c2} and output voltage V_{out} of push-push VCO with second harmonic output at 24GHz (a) and third harmonic output at 36 GHz (b); spectrum of V_{out} of 24 GHz VCO (c); spectrum of V_{out} of 36 GHz VCO (d).

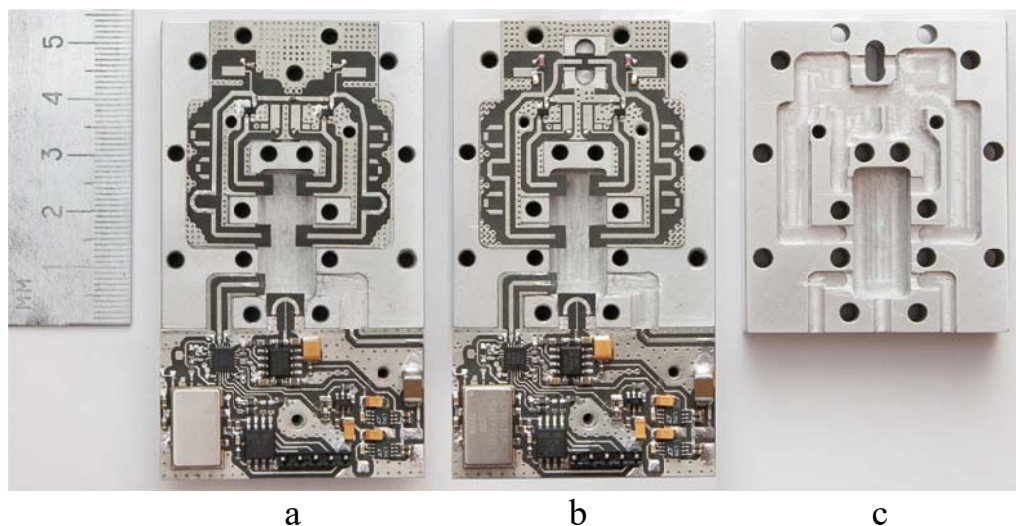

Fig. 4. PLL controlled push-push VCO samples with second harmonic output at 24 GHz (a) and third harmonic output at 36 GHz (b) with metal cover (c) removed.

DC bias of collector-emitter voltage $V_{CE} = 2$ V and collector current $I_C = 10$ mA was found to be the optimum trade-off between harmonic levels and phase noise. Time domain collector voltages and spectrum components of output sig-

nals are shown in fig. 3. Results of the phase noise simulation are shown in fig. 7 next to the measurement results.

The picture of PLL stabilised VCO samples is illustrated in fig. 4. With the cover being removed the metal bases with installed substrates of push-push oscillators and PLL synthesizers are shown. The board with active bias circuits for $VT1$ and $VT2$ transistors is located on the opposite side of the base. The design uses low cost commercial off-the-shelf parts.

Measurement results

The resonator quality factor measurement was performed using a Keysight E5071C network analyzer. The resonator was coupled with external circuit by means of two probes, which were tuned to have coupling factor of $\beta_1 = \beta_2 = 0,5$. The loaded quality factor was calculated from half power bandwidth of S_{21} frequency response at the vicinity of 11,97 GHz resonance frequency: $Q_L = 1489$, which corresponds to unloaded quality factor of $Q_U = 2978$. The significant difference between measured and theoretically obtained values [10] can be explained by poor surface roughness of resonator walls, which was deliberately not controlled in order to estimate the performance of low cost process.

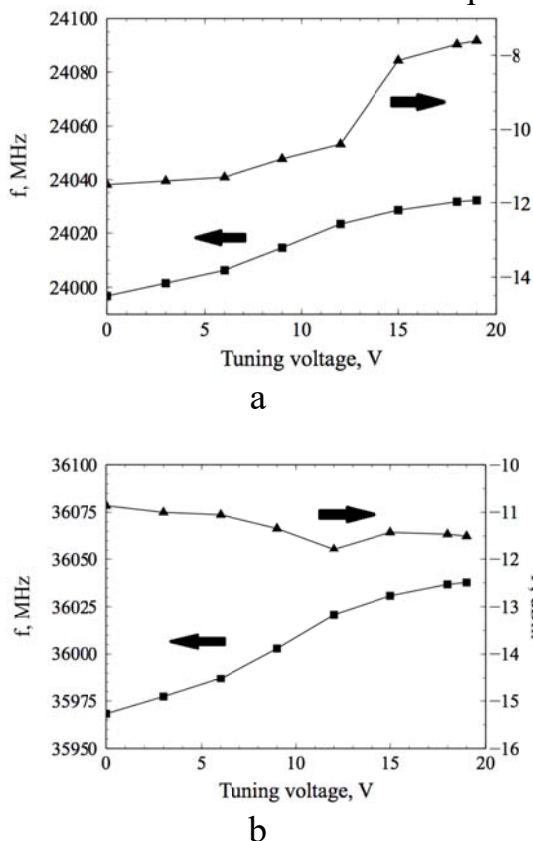

Fig. 5. Output power and frequency versus tuning voltage of push-push VCOs with second harmonic output at 24 GHz (a) and third harmonic output at 36 GHz (b).

Output power and frequency of 24 GHz and 36 GHz VCOs measured across 19 V of tuning range are shown in fig. 5. Output power of 24 GHz push-push VCO varies within the range of $-11,5 - -7,6$ dBm. 36 GHz push-push VCO with third harmonic output demonstrates $-11,8 - -10,9$ dBm of output power.

Frequency tuning range of 24 GHz VCO covers 23,997 - 24,032 GHz (0,15%) with average K_{VCO} of 1,86 MHz/V, 36 GHz version shows 35,968 - 36,038 GHz (0,19%) of frequency control range with average K_{VCO} of 3,65 MHz/V. Both versions are able to compensate frequency drift due to temperature change of $\Delta T = 81^\circ\text{C}$.

Output spectrum of 24 GHz push-push VCO is similar to the one of free running oscillator shown in [10], it demonstrates a level of -21 dBc of fundamental component. Spectral components of the push-push VCO with third harmonic output at 36GHz are shown in fig. 6. Fundamental harmonic is not observable above the noise level of Keysight E4448A spectrum analyzer, it is suppressed at better than -59 dBc.

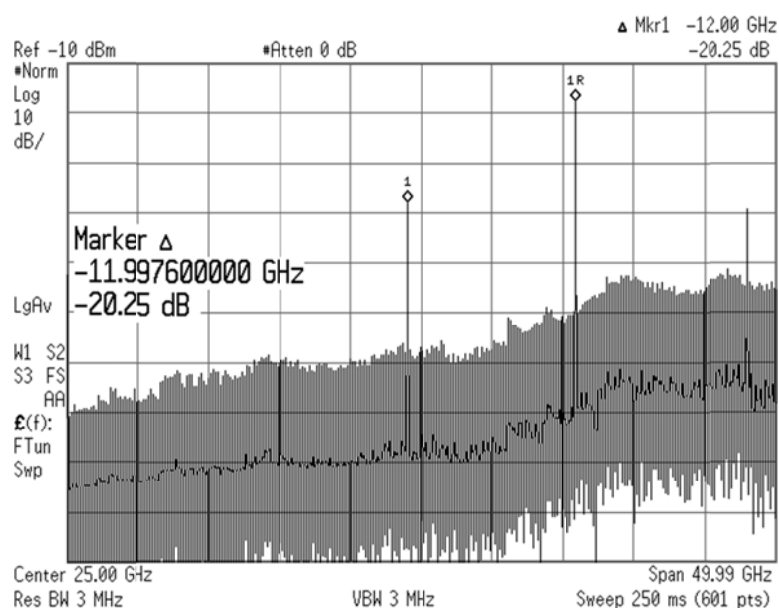

Fig. 6. Harmonic components of PLL controlled push-push VCO with second harmonic output.

Second harmonic level is $-20,2$ dBc and the fourth one has a level of -23 dBc. Second harmonic level can be improved significantly by using $5,2 \times 2,6$ mm output waveguide opening (EIA WR22), which will shift the cutoff frequency to 28,8 GHz and thus strongly suppress component at 24 GHz. A finite levels of fundamental component suppression in 24 GHz VCO and of second and fourth harmonics in 36 GHz VCO (in contrast to formulas (4) and (5)) are observed due to impairments in practical oscillator circuits. Differences between the suboscillators' electrical lengths of feedback loops ($l_1 + l_2$) and output lines l_3 , probes, transistors and their biasing contribute to phase and amplitude disbalance of collector voltages and thus lead to a limited suppression of components with opposite phases.

Phase noise measurements of PLL controlled VCOs are shown in fig. 7. Measurements were performed on Keysight E4448A spectrum analyzer at 36 GHz and on Keysight E5052B signal source analyzer at 24 GHz and 12 GHz. For 36 GHz push-push VCO with third harmonic output achieved levels were –67 dBc/Hz at 1 kHz, –87,4 dBc/Hz at 10 kHz, –107 dBc/Hz at 100 kHz and –120 dBc/Hz at 1 MHz offset. PLL filter bandwidth was set to 1 kHz. However, the measured noise for offsets above 20 kHz was affected by the noise floor of the instrument. For 24 GHz push-push VCO phase noise was measured at –70,2 dBc/Hz at 1 kHz, –91 dBc/Hz at 10 kHz, –123,5 dBc/Hz at 100 kHz and –140,5 dBc/Hz at 1 MHz offset. Phase noise of the PLL controlled push-push VCO measured at fundamental frequency demonstrates consistency with the measurement at second harmonic of 24 GHz.

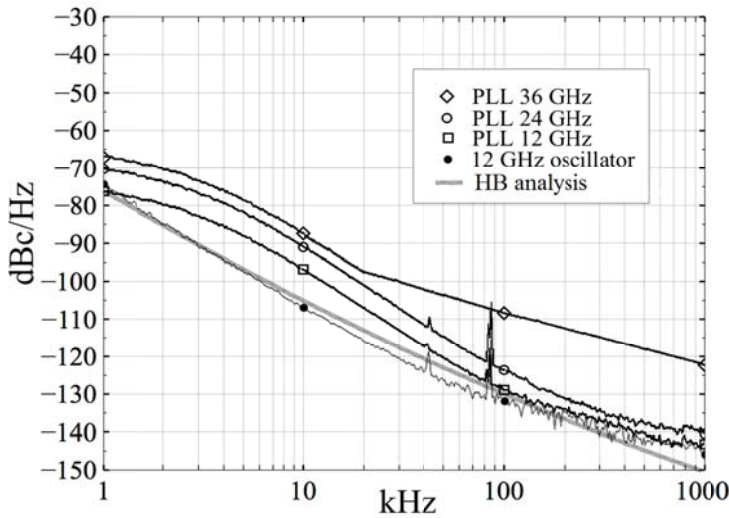

Fig. 7. Measured phase noise of PLL controlled VCOs ; measured and calculated phase noise of free running push-push oscillator at 12 GHz.

frequency. One can observe 11 dB of noise degradation at 10 kHz offset due to impact of tuning varactors (fig. 7).

Conclusion

A low cost and low phase noise quaziplanar PLL controlled push-push VCOs based on a rectangular waveguide cavity resonator at 24 GHz and 36 GHz output frequencies has been designed using off-the-shelf components. Push-push VCO at 36 GHz implements a third harmonic output concept which provides benefits of higher output frequency compared to conventional push-push oscillator design and less occupied space in contrast to triple-push design approach. Phase noise performance of the oscillators is in the same range of more costly dielectric resonator oscillators in K- and Ka-bands. Further improvement of phase noise is possible by using resonator of higher quality factor such as cylindrical cavity at TE₀₁₁ mode.

The PLL controlled VCOs can be used as low phase noise local oscillators in digital communication channels with high order modulation schemes.

References

1. Kobayashi Y., and Minegishi M. (1987) Precise Design of a Bandpass Filter Using High-Q Dielectric Ring Resonators. [*IEEE Transactions on Microwave Theory and Techniques*](#), vol. 35, no. 12, pp. 1156-1160.
2. Zhou L., Yin W.-Y., and Mao J.-F. (2009) Substrate integrated high-Q dielectric resonators for low phase noise oscillator. [*IEEE EDAPS*](#), pp. 1-4.
3. Maree J., De Swardt J.B., and Van der Walt P.W. (2013) Low Phase Noise Cylindrical Cavity Oscillator. [*AFRICON*](#), pp. 1-5.
4. Wanner R., Lachner R., and Olbrich G.R. (2006) Monolithically Integrated SiGe Push-push Oscillators in the Frequency Range 50-190 GHz. [*Spread Spectrum Techniques and Applications, IEEE Ninth Int. Symp.*](#), pp. 26-30.
5. Sinnesbichler F. X. (2003) Hybrid Millimeter-Wave Push-Push Oscillators Using Silicon-Germanium HBTs. [*IEEE Transactions on Microwave Theory and Techniques*](#), vol. 51, no. 2, pp. 422-430.
6. Bender J. R., and Wong C. (1983) Push-Push Design Extends Bipolar Frequency Range. [*Microwaves & RF*](#), pp. 91-98.
7. Sinnesbichler F.X., Geltinger H., and Olbrich G.R. (1999) A 38-GHz push-push oscillator based on 25-GHz fT BJT's. [*IEEE Microwave and Guided Wave Letters*](#), Vol. 9, No. 4, pp. 151-153.
8. Hyun A.-S., Kim H.-S., Park J.-Y., Kim J.-H., Lee J.-C., Kim N.-Y., Kim B.-K., and Hong U.-S. (1999) K-band hair-pin resonator oscillators. [*IEEE MTT-S International Microwave Symposium Digest*](#), vol. 2, pp. 725-728.
9. Kotserzhynskiy B., Omelianenko M., and Tsvelykh I. (2009) A Low Phase Noise Microstrip Push-push Oscillator With Third Harmonic Output. [*International Conference on Antenna Theory and Techniques*](#), pp. 337-339.
10. Tsvelykh I. (2014) Quasi-planar K-band push-push low phase noise oscillator stabilized by cavity resonator. [*Radioelectronics and Communications Systems*](#), vol. 57, no. 9, pp. 428-431.
11. Cressler J. D. (1998) SiGe HBT technology: A new contender for Si-based RF and microwave circuit applications. [*IEEE Transactions on Microwave Theory and Techniques*](#), Vol. 46, pp. 572-589.
12. Russer P. (1998) Si and SiGe millimeter-wave integrated circuits. [*IEEE Transactions on Microwave Theory and Techniques*](#), vol. 46, pp. 590-603.
13. Everard J.K.A. (1997) A Review of Low Noise Oscillator. Theory and Design. [*Proc. of the IEEE International Frequency Control Symposium*](#), pp. 909-918.
14. Yu-Lung Tang, and Huei Wang. (2001) Triple-push oscillator approach: theory and experiments. [*IEEE Journal of Solid-State Circuits*](#), Vol. 36, No. 10, pp. 1472-1479.
15. Van der Toorn R., Paasschens J.C.J., and Kloosterman W.J. (2008) [*The Mextram Bipolar Transistor Model. Level 504.7*](#). Delft University of Technology. Available at: http://www.nxp.com/wcm_documents/models/bipolar-models/mextram/mextram_definition_504.7.pdf

Цвєлих І. С., Коцєржїнський Б. О. Двотактні ГКН К- та Ка- діапазонів на основі об'ємного резонатора, стабілізовані ФАПЧ, з малим рівнем фазового шуму та низькою вартістю. У роботі представлені результати розробки двотактних генераторів, керованих напругою К-діапазона (24 ГГц) з виходом на другій гармоніці та Ка-діапазона (36 ГГц) з виходом на третій гармоніці, а також синтезаторів з ФАПЧ на основі запропонованих генераторів. Генератори стабілізовані об'ємним резонатором на основі відрізка прямокутного хвилевода. Потужність вихідного сигналу в діапазо-

нах перестроювання змінюється в межах $-11,5 - -7,6$ дБм та $-11,8 - -10,9$ дБм для генераторів 24 ГГц та 36 ГГц відповідно. Рівні фазового шуму в боковій смузі для ГКН, стабілізованих петлею з ФАПЧ, складають -91 дБн/Гц для генератора 24 ГГц та $-87,4$ дБн/Гц для генератора 36 ГГц на 10 кГц відстроювання від носійної, що знаходиться на рівні характеристик генераторів на діелектричних резонаторах. Генератори мають малі розміри, високотехнологічну квазіпланарну конструкцію та побудовані з комерційно доступних елементів.

Ключові слова: генератор з малим рівнем фазового шуму; двотактний генератор; двотактний генератор з виходом на третій гармоніці; генератор, керований напругою; генератор на основі об'ємного резонатора; синтезатор з ФАПЧ

Цвелых И. С., Коцержинский Б. А. Двухтактные ГУН К- и Ka- диапазонов на основе объемного резонатора, стабилизированные ФАПЧ, с малым уровнем фазового шума и низкой стоимостью. В работе приведены результаты разработки двухтактных генераторов, управляемых напряжением К-диапазона (24 ГГц) с выходом на второй гармонике и Ka-диапазона (36 ГГц) с выходом на третьей гармонике, а также синтезаторов с ФАПЧ на основе представленных генераторов. Генераторы стабилизированы полым резонатором на основе отрезка прямоугольного волновода. Мощность выходного сигнала в диапазонах перестройки изменяется в пределах $-11,5 - -7,6$ дБм и $-11,8 - -10,9$ дБм для генераторов 24 ГГц и 36 ГГц соответственно. Уровни фазового шума в боковой полосе для ГУН, стабилизированных петлей с ФАПЧ, составляют -91 дБн/Гц для генератора 24 ГГц и $-87,4$ дБн/Гц для генератора 36 ГГц на 10 кГц отстройки от несущей, что находится на уровне характеристик генераторов на диелектрических резонаторах. Генераторы имеют малые размеры, високотехнологичную квазіпланарную конструкцию и построены из коммерчески доступных элементов.

Ключевые слова: генератор с малым уровнем фазового шума; двухтактный генератор; двухтактный генератор с выходом на третьей гармонике; генератор, управляемый напряжением; генератор на основе полого резонатора; синтезатор с ФАПЧ

Tsvelykh I. S., Kotserzhynskiy B. O. Low cost low phase noise PLL controlled push-push VCOs in K- and Ka- bands, stabilized by cavity resonator. This work demonstrates push-push VCOs in K-band (with second harmonic output at 24 GHz) and in Ka-band (with third harmonic output at 36 GHz), and PLL synthesizers on their basis. Oscillators are stabilized by a rectangular resonant metallic cavity. Output signal power within the frequency tuning range changes in the limits of $-11,5 - -7,6$ dBm and $-11,8 - -10,9$ dBm for 24 GHz and 36 GHz oscillators respectively. Single sideband (SSB) phase noise spectral densities of -91 dBc/Hz for 24 GHz oscillator and $-87,4$ dBc/Hz for 36 GHz oscillator at 10 kHz offset from the carrier frequency are at the level of dielectric resonator oscillators (DRO) scaled to the same frequency. The oscillators feature a compact size, low cost quasi-planar design and are built using commercially available off-the-shelf parts.

Keywords: low phase noise oscillator; push-push oscillator; push-push oscillator with third harmonic output; voltage controlled oscillator; cavity stabilized oscillator; PLL synthesizer