

PACS: 61.72.Cc, 61.72.Mm, 61.72.Ff, 61.72.Hh, 68.35.Gy

## The technique of simultaneous investigation of the laws of occurrence and development of rotational and translational modes in situ during plastic deformation of the samples

K.S. Kazachkova, R.V. Shurinov, E.E. Badiyan

*Department of Physics, Department of Solid State Physics,  
Kharkov National University, 4 Svoboda Sq., 61077 Kharkov, Ukraine  
Evgeny.E.Badiyan@univer.kharkov.ua*

The described technique, allowing in situ in the process of plastic deformation of samples at the same time monitor the emergence and development of translational and rotational modes. The first method uses a technique of producing color cards orientation and imaging them colors. In the second - the effect of laser diffraction on quasi-periodic deformation relief in the form of slide steps. The color orientation maps allow to determine the characteristics of the substructure with a linear resolution  $\sim 1$  micron and angular  $\sim 10$  seconds.

Using the laser technique makes it possible is to follow the emergence and development of sliding and determine characteristics such as sliding direction and its change in the deformation of the sample, the minimum distance between slip lines characterizing the intensity of slip and slip lines degree of curvature that characterizes the strengthening investigated sample.

**Keywords:** color orientation map, rotational mode, translational mode, the plastic deformation.

Описана методика, що дає можливість in situ в процесі пластичного деформування зразків одночасно стежити за виникненням і розвитком ротаційної і трансляційної мод. У першому випадку використовується методика отримання кольорових орієнтаційних карт і візуалізації на них відтінків кольорів. У другому - ефект дифракції лазерного випромінювання на квазіперіодичному деформаційному рельєфі в вигляді сходинок ковзання. Кольорові орієнтаційні карти дозволяють визначити характеристики субструктури з лінійною роздільною здатністю  $\sim 1$  мк, і кутовим  $\sim 10$  сек.

Використання лазерної методики дає можливість є простежити за виникненням і розвитком ковзання і визначити такі характеристики як напрямок ковзання і його зміна в процесі деформування зразка, мінімальна відстань між лініями ковзання, що характеризує інтенсивність розвитку ковзання, а також ступінь викривлення ліній ковзання, що характеризує зміцнення досліджуваного зразка.

**Ключові слова:** колірні орієнтаційні карти, ротаційна мода, трансляційна мода, пластична деформація.

Описана методика, позволяющая in situ в процессе пластического деформирования образцов одновременно следить за возникновением и развитием ротационной и трансляционной мод. В первом случае используется методика получения цветowych ориентационных карт и визуализации на них цветowych оттенков. Во втором – эффект дифракции лазерного излучения на квазипериодическом деформационном рельефе в вид ступенек скольжения. Цветовые ориентационные карты позволяют определить характеристики субструктуры с линейным разрешением  $\sim 1$  мк, и угловым  $\sim 10$  сек.

Использование лазерной методики позволяет проследить за возникновением и развитием скольжения и определить такие характеристики как направления скольжения и его изменение в процессе деформирования образца, минимальное расстояние между линиями скольжения, характеризующее интенсивность развития скольжения, а также степень искривления линий скольжения, характеризующих упрочнение исследуемого образца.

**Ключевые слова:** цветowych ориентационные карты, ротационная мода, трансляционная мода, пластическая деформация.

### Introduction

It is well known that the mechanical properties of crystalline samples are structurally highly sensitive. The mechanical characteristics of the sample under study depend not only on the initial structure and substructure, but also on the nature of change in the process of plastic flow. Plastic deformation of crystalline samples is characterized by two modes - translational and rotational. In the first case, as a result of plastic deformation of the elementary event

- slip dislocations on the sample surface at the exit site of dislocation occurs in the form of steps relief whose shape, size, number, orientation, and other parameters can judge and the mechanism of occurrence of plastic deformation. Similarly, in the second case, when the plastic deformation is characterized by a rotary mechanism, there is a reversal of certain parts of the sample, which can significantly change not only share in the plastic deformation of the translation mode, but also to make an independent contribution (in

some cases substantial) in the plastic deformation of the entire sample .

In recent years, developed a number of techniques [1, 2, 3, 4], that allow using color maps to determine the orientation and orientation substructural characteristics of the sample and monitor in situ for their change in the course of its deformation. Using the method of imaging hues [5, 6] it is possible to determine the parameters of the linear substructural  $\sim 1$  micron resolution and angular  $\sim 10$  seconds.

The traditional method of determining the translational component of plastic deformation based on a study of the strain relief in the form of steps slip occurring on the polished surface of the sample [7].

Experimental studies patterns of plastic deformation of polycrystalline samples made in recent years have shown that it is impossible not only to determine and predict the occurrence and sequence of deformation modes, thus characterize a pattern of plastic deformation in the whole sample. The main reason is the lack of experimental techniques which allow the process of plastic deformation synchronously follow the emergence and development of shear and rotation deformation modes.

The simultaneous use methods of obtaining color orientation maps and thus define substructural characteristics and their changes in the process of deformation of the sample to the entire working surface of the sample and methodology of the study of deformation structures in the form of sliding steps will enable to trace the origin and development of different modes of plastic deformation, to determine the role of each of them in the plastic deformation of the whole of the sample and eventually to describe the mechanism of plastic deformation of the specimen.

Aim of this study was to develop a technique for the simultaneous investigation of translational and rotational fashion plastic deformation of the sample in situ during its deformation.

#### Description of the experimental setup

Scheme of the experimental setup is shown in Fig. 1. On the base plate (3) of the deforming device at different sides test sample installed two devices: one for registration color orientation maps, another - for the registration in situ during the plastic deformation of the diffraction pattern formed by diffraction of the laser radiation on elements of the strain relief arising on the surface of the sample during its plastic deformation. For experimental studies it is necessary that one of the working surfaces of the sample (1) was polished, to identify the strain relief on it and recording the diffraction patterns on this relief by laser using a web camera (4), the other for the purpose of chemically etched identifying on it a quasiperiodic relief with which the interaction of white light leads to the effect of diffraction of [2] and, consequently, to the

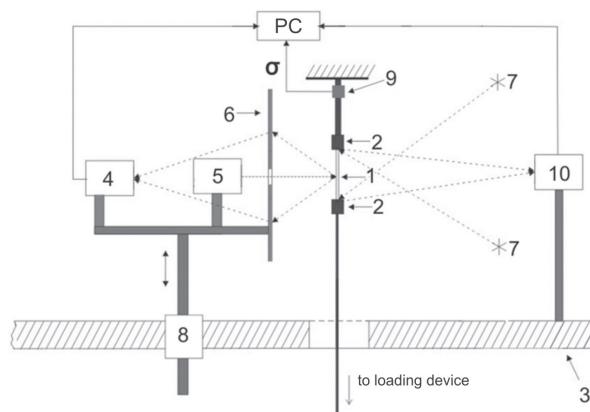

Fig. 1. The experimental setup.

appearance of color orientation maps recorded by using a Web camera (10). Due to the fact that the size of the laser beam on the sample surface are insignificant ( $2 \times 2$  mm<sup>2</sup>) in the installation has a device (8) for scanning the laser beam across the sample surface. The scanning speed was 10 mm / sec. Special screen (6) is transparent to the laser radiation ( $\lambda=630$  nm) allows to record diffraction patterns with a digital camera. Voltage measuring deformation unused specially made elastic element (9) with adhesive on it, and strain gauges connected in a bridge circuit. The deformation of the sample was carried out using a special loading device, which was the ultimate force  $\sim 5$  kg. The rate of deformation of the sample -  $\sim 10^{-5}$  s<sup>-1</sup>. All information about the sample in the form of color orientation maps, laser diffraction patterns and the deformation curve in coordinates  $\sigma = \sigma(\epsilon)$  synchronous recorded with a PC with a period of 0,01 seconds.

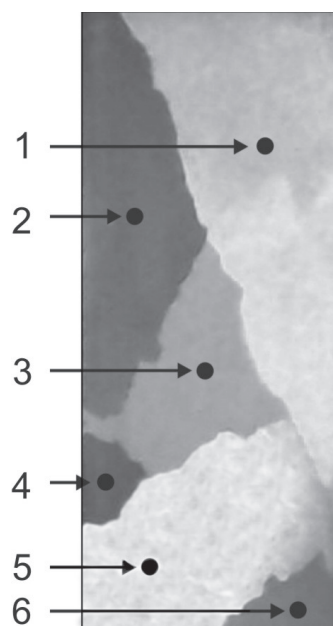

Fig. 2. The color orientation map of the surface of the individual grains of the polycrystalline sample aluminum after deformation by 17%.

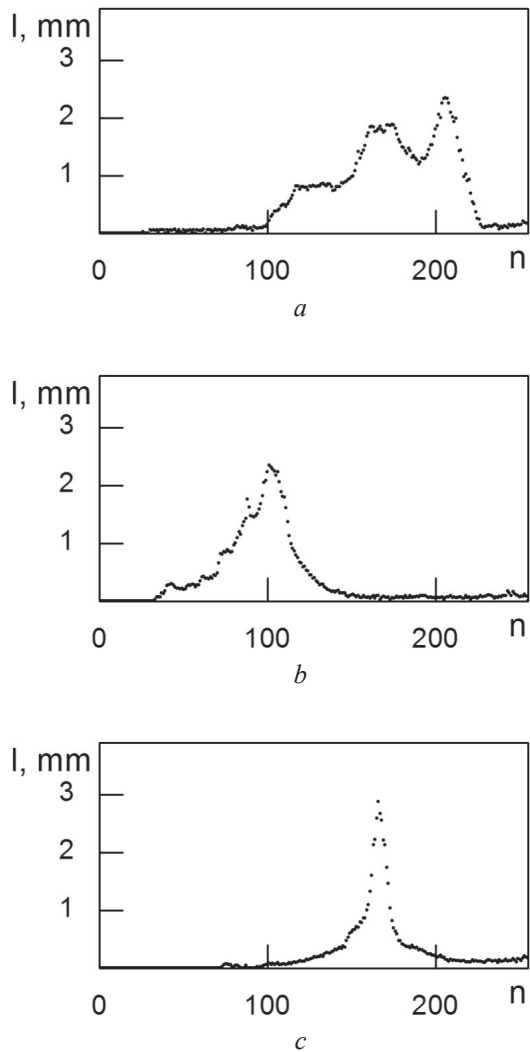

Fig. 3. Distribution of the elements of the substructure in various size grains of a polycrystalline sample after 17% deformation (a - grain 1, b - grain 2, c - 3 grain).

### Research results and their discussion

As an example, in Fig. 2. Bring the color orientation map of the surface of the individual grains of a

polycrystalline sample of aluminum after deformation by 17%.

Color image of the surface of the grains uniform, which indicates the presence in the sample of the substructure elements [3]. Fig. 3. provide information on the distribution of elements of the substructure for the size of the sample before and after the deformation of 17%, obtained using the method of visualization [5] The colors in the COM. From Fig. 3 that when the deformation of 17% in the 1-st (a) and 2-nd (b) the grain is its division into blocks with a decrease in the average block size, and expanding the range of their disorientation. In the 3-rd grain (c) in the process of deformation of the sample, and the average size of the block range of misorientation not changed. This grain is in the process of plastic deformation unfolding as a whole.

Distribution curves subgrain size and crystallographic orientation to third grain deformation to the sample and after deformation of 17% are shown in Fig. 3 c.

Thus, effects rotation of the first and second grain manifested in a change in orientation of the sample during deformation substructure elements, their crushing and spreading of these changes, and the third average grain size subgrain disorientation and their spectra remain practically unchanged. In the process of deformation of the grain subgrain orientation change occurs, leading to a change in the orientation of the grain as a whole.

Here, in Fig. 4 shows typical laser diffraction patterns obtained from the grains mentioned above, after the deformation of the sample by 17%.

For grain 1 with a well-developed structure of a rotary slip traces are found almost, so there is no diffraction pattern (Fig. 3 a). On the surface of grain 3 after the deformation of the sample at 17% deformation relief formed in the form of steps at the exit site slip dislocations. This is evidenced by the form of the diffraction pattern resulting from the interaction of the laser beam with the relief (Fig. 3 c). Analysis color maps of the orientation obtained from the surface of the grain, showing that the effect of grain in the crushing process of deformation of the sample takes place.

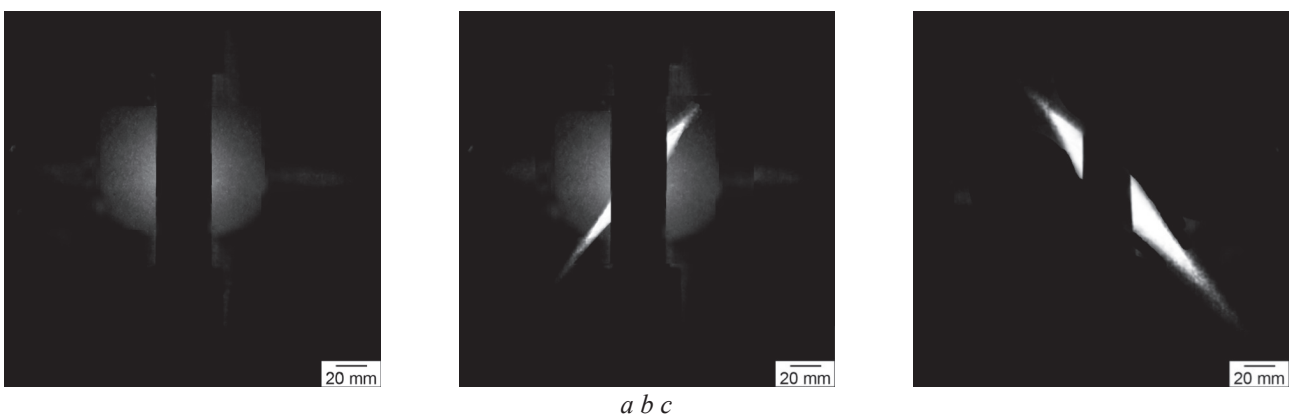

Fig. 4. Laser diffraction patterns from the surface of the grains of the polycrystalline sample 1,2,3 after deformation by 17%.

### **Conclusions**

1. The technique allows to simultaneously investigate the emergence and development of translational and rotational deformation modes of the sample in situ in the process of deformation has been proposed.

2. Using a laser technique [8] allows not only to register the occurrence of strain relief, but also the character of its development in the process of deformation of the sample. By the form of the diffraction pattern can determine the direction of the slide and the change in the deformation process. The shape and size of the diffraction pattern (in view of its reflexes) can be defined such substructural characteristics of plastic flow [8] as the minimum distance between slip lines, characterized by intensive development of plastic deformation and the character of the curvature of the slip lines defining the pattern of hardening of the sample.

1. Patent 89743 UKRAINE, the IPC G01B 11/16. E.E. Badiyan, A.G. Tonkopyrad, O.V. Shekhovtsov, R.V. Shurinov; The applicant and patent owner V.N. Karazin KNU. - № a 2009 06455; appl. 22.06.09; publ. 25.02.10, Bul. №4.
2. E.E. Badiyan, A.G. Tonkopyrad, O.V. Shekhovtsov, R.V. Shurinov. *Functional Materials*, 3, 3, 411, 2006
3. E.E. Badiyan, A.G. Tonkopyrad, O.V. Shekhovtsov, R.V. Shurinov, T.R. Zetova. *Inorganic Materials*, 15, 1663 (2011).
4. E.E. Badiyan, A.G. Tonkopyrad, O.V. Shekhovtsov, R.V. Shurinov, T.R. Zetova. *Factory Laboratory. Diagnosis materials*, 76, 8, 34, (2010).
5. Patent 104249 UKRAINE, the IPC (2013.01), G01N 21/00, G01N 33/20 (2006.1). E. E. Badiyan, A. G. Tonkopyrad, O. V. Shekhovtsov, R. V. Shurinov, T. R. Zetova, K. S. Kazachkova; The applicant and patent owner V.N. Karazin KNU. – № a 2012 14845; appl. 24.12.12.; publ.10.01.14, Bul. №1.
6. E. E. Badiyan, A. G. Tonkopyrad, O. V. Shekhovtsov, R. V. Shurinov, T. R. Zetova, K. S. Kazachkova. *Functional Materials*, 21, 3, 307 (2014).
7. G.A. Malygin. *Solid State Physics*, 43, 2, 248 (2001).
8. E. E. Badiyan, A. G. Tonkopyrad, O. V. Shekhovtsov, R. V. Shurinov, T. R. Zetova, K. S. Kazachkova. *Functional Materials*, 22, 3 (2015).