

V. Mazur, D. Yaremchuk
Lviv Polytechnic National University,
CAD Department

DEVELOPMENT OF SOFTWARE AND HARDWARE FOR PRIMARY DIAGNOSTICS OF CARDIOVASCULAR DISEASES

Ó Mazur V., Yaremchuk D., 2018

The software and hardware for the primary diagnostics of cardiovascular diseases at home are presented in this paper. The model of the diagnostic laboratory as a system of mass service is proposed. The results of the research of the cardiovascular system by the developed means are presented.

Key words: primary diagnostics at home, computer diagnostics, cardiovascular diseases, software and hardware.

РОЗРОБЛЕННЯ АПАРАТНОГО ТА ПРОГРАМНОГО ЗАБЕЗПЕЧЕННЯ ДЛЯ ПЕРВИННОЇ ДІАГНОСТИКИ СЕРЦЕВО-СУДИННИХ ЗАХВОРЮВАНЬ

Ó Mazur V., Яремчук Д., 2018

Описано програмне та апаратне забезпечення для первинної діагностики серцево-судинних захворювань у домашніх умовах. Запропонована модель діагностичної лабораторії як системи масового обслуговування. Подано результати досліджень серцево-судинної системи розробленими засобами.

Ключові слова: первинна діагностика вдома, комп'ютерна діагностика, серцево-судинні захворювання, програмне та апаратне забезпечення.

Introduction

Timely diagnosis of diseases in the early stages of development provides their successful treatment. This is especially true of cardiovascular disease (CVD), which affects many young patients and most the older patients. However, many of them do not suspect the presence of the disease.

For early detection of these diseases, mass prophylactic examinations are required. However, the existing number of medical devices and diagnostic laboratories cannot provide such surveys due to their lack of bandwidth. In addition, a significant number of patients cannot make such examinations during working hours through employment at work or training. Therefore, an approach, based on conducting a patient's self-primary diagnostics at home, by using available (at a price) devices and a personal computer is being developed. The data collected during the survey process are processed by a computer program, and the results obtained and documented are grounds for referring to the doctor for in-depth diagnostic research in outpatient settings and appointment of treatment. The perspective of this approach is confirmed by the widespread use of thermometers, tonometers, glucometers at home. Therefore, the task of developing available hardware and software for the primary diagnosis of CVD at home condition is definitely relevant.

The purpose of the work is to develop the means for the primary diagnostics of CVD at home.

To achieve this goal, the following tasks are solved:

1. Analysis and evaluation of the functioning of the diagnostic laboratory as a system of mass service.
2. Development of hardware and software for primary diagnostics of CVD at home condition.

Analysis and evaluation of diagnostic laboratory as a mass service system

Possibility of carrying out mass diagnostic surveys of the population is determined by the availability of necessary medical equipment and the capacity of diagnostic centers and laboratories. When conducting diagnostic studies of a specific type (cardiography, radiography, etc.), the diagnostic laboratory can be considered as a mass service system. The dependencies indicated in [1] are used to determine the bandwidth and evaluate the functioning of such a system. It is assumed that for a certain time interval during a day, the flow of patients is Poisson and is characterized by the intensity λ . To determine the parameters, characterizing the functioning of the laboratory, the number of devices k , that can be used to perform a specific test, the mean time of one survey $E(s)$ and the intensity of the patients flow λ are indicated. The values of these parameters can be obtained as a result of experimental laboratory examinations (Table. 1).

Table 1

The results of the cardio-graphic laboratory examination

№	Ta	Tp	Te	ΔT	Tw	Tm	Ts
1	10.34	10.56	11.03	6	22	7	29
2	10.39	11.03	11.10	5	24	7	31
3	10.45	11.10	11.16	6	25	6	31
4	11.02	11.16	11.21	17	14	5	19
5	11.05	11.21	11.26	3	16	5	21
6	11.12	11.26	11.31	7	14	5	19
7	11.15	11.31	11.36	3	16	5	21
8	11.28	11.36	11.41	13	8	5	13
Average value				7.5	17.4	5.6	23

Where: Ta – the time of the patient arrival;
 Tp – the time of the procedure beginning;
 Te – the time of the procedure completion;
 ΔT – the time interval between the arrival of the $i-1$ and i patient;
 Tw – waiting time;
 Tm – the duration of the procedure;
 Ts – the total time spent by the patient;
 $\lambda = 8/(11.28-10.28) = 8$ patients/hour.

The parameters that characterize the laboratory, as a system of mass service, are given in Table 2.

Table 2

Parameters of the mass service system

E(s)=5.5, k=1, $\lambda=8$		E(s)=5.5, k=2, $\lambda=8$		E(s)=5.5, k=2, $\lambda=16$	
Parameter name	Value	Parameter name	Value	Parameter name	Value
Average time interval between arrival of patients, minutes	7.5	Average time interval between arrival of patients, minutes	7.5	Average time interval between arrival of patients, minutes	3.75
Relative intensity	0.73	Relative intensity	0.73	Relative intensity	1.47
Loading	0.73	Loading	0.37	Loading	0.73
Probability of employment	0.73	Probability of employment	0.2	Probability of employment	0.62
Average waiting time, minutes	15.1	Average waiting time, minutes	0.85	Average waiting time, minutes	6.4
Total spent time, minutes	20.6	Total spent time, minutes	6.4	Total spent time, minutes	11.9

The obtained calculation parameters are close to those determined experimentally. Using two cardiographs at $\lambda = 8$ is inappropriate due to the low utilization coefficient. With a significant increase in

the flow of patients ($\lambda = 16$), it is advisable to use two cardiographs with their combined use (the cardiogram is obtained on any free cardiograph and only when the two of them are employment then patient waits in the queue).

Development of hardware and software for primary diagnostics of CVD at home

The development of microelectronics and computer technology provides the creation of modern medical devices for the implementation of diagnostic methods of CVD. Among such methods electrocardiography, echocardiography, arteriography, dopplerography, and others are most often used. These methods are used for in-depth surveys in outpatient settings and require expensive medical equipment and qualified medical personnel. However, the bandwidth of diagnostic laboratories does not provide conducting of mass surveys for primary diagnosis of CVD in the early stages of their development.

One of the manifestations of CVD is arterial hypertension. For measurement of blood pressure in outpatient and home conditions, mechanical tonometers are used that implement the Korotkov's method. They provide greater accuracy compared to the oscilloscopic method in automatic devices. In addition, Korotkov's method is officially approved for measuring pressure in medical institutions during diagnostics. Therefore, the proposed device for primary diagnostics at home is implemented on the basis of a mechanical tonometer.

The block diagram of the designed device is shown in Fig. 1.

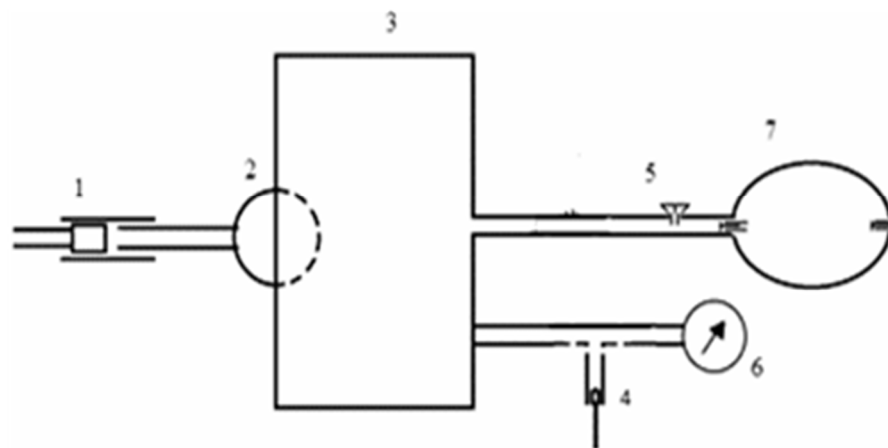

Fig. 1. Block diagram of the designed device

It consists of two high-sensitivity miniature microphones, a dual-channel pre-amplifier and a stereo power amplifier to which two speakers are connected. The use of amplifiers and speakers allows patients with hearing impairment to independently measure their pressures. Each microphone (1) is mounted in a rubber tube connected to the head of the phonendoscope (2). This head is inserted under the cuff of the tonometer. A coupler, equipped with a calibrated medical needle (4), is attached between the cuff (3) and the pressure gauge (6) to provide the recommended pressure drop (5 mm Hg) during the measurement. A valve (5) is installed between the cuff (3) and the pear (7) to quickly lower the pressure after the measurements are completed. The output signal from the linear output of the previous amplifier is fed to the input of the sound card of the personal computer. The analogue-to-digital converters located on the sound card converts analog signals from both microphones into digit codes, which are recorded on a magnetic disk in the form of a WAV file. The sampling rate of 8000 bits per second provides a frequency range of 20–3500 Hz and the number of quanta ± 127 provides an accuracy of 0.4 %, while the Stereo mode provides dual-channel recording and playback. The general view of the device is presented in Fig. 2.



Fig. 2. General view of the proposed device

The resulting digital data is transmitted to the developed program for processing, analysis and visualization. Graphic representation of the five phases of the Korotkov's tones in changing of the cuff pressure from 170 to 80 millimeters of mercury column is presented in Fig. 3.

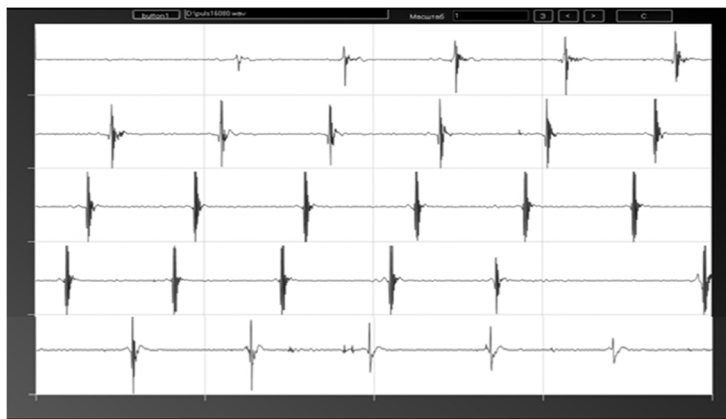

Fig. 3. Graph of the Korotkov's tones

A more detailed graph of Korotkov's tones in case of arrhythmia is presented in Fig. 4.

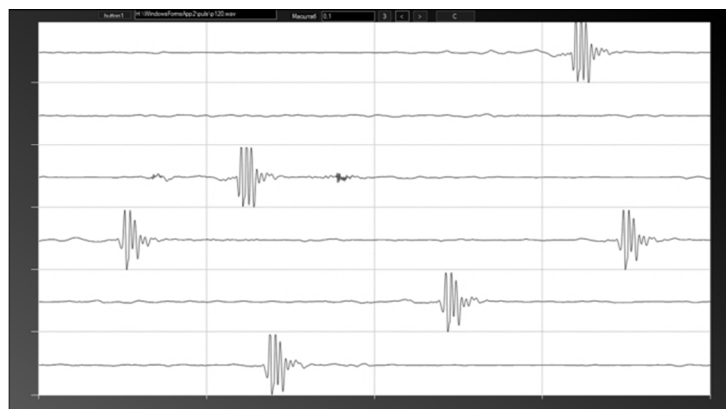

Fig. 4. Graph of Korotkov's tones in case of arrhythmia

In the process of visualization and analysis of the obtained graphs (by computer or physician), the following pathologies of the cardiac system can be detected: arrhythmia, tachycardia, bradycardia, and heart rhythm disturbances in the presence of extra-systoles.

When applying the two cuffs (on forearm and wrist) on base the graphs for two channels, one can determine the delay between the Korotkov's tones ΔT (with cuff pressure of 100 millimeters of mercury column). If delay ΔT and distance between cuffs ΔL (0.3–0.35 m) is known, it is possible to determine the rate of pulse wave propagation $V = \Delta L / \Delta T$, which can be used for diagnostic purposes (Fig. 5).

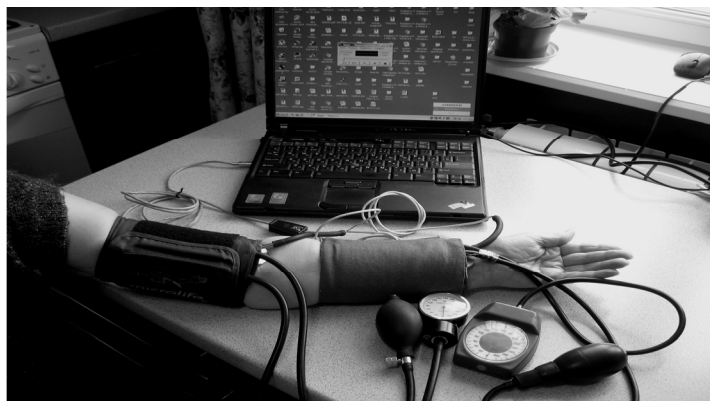

Fig. 5. Determination of the rate of pulse wave propagation

In outpatient settings, recording on one of the channels the sound sync pulse of the electrocardiograph can synchronize charts of the electrocardiogram and Korotkov's tones for their joint use in the diagnosis of diseases. The developed device also provides registration of pulse oscillations for obtaining a sifzogramme. For this, the tube with the microphone joins the splitter between the cuff and the pressure gauge. In this case, the pressure in the cuff should be about 100 millimeters of mercury column.

The computer program informs the patient about the revealed pathology and recommends referring to the doctor (with the received data and graphs) for carrying out (in an outpatient condition) of in-depth diagnostics and appointment of treatment.

The primary diagnostics of vascular diseases on the basis of body's temperature analysis at characteristic points.

For the diagnosis of vascular diseases in the home environment, a hypothesis was put forward for the relationship between the state of the circulatory system and the body temperature of the patient in the characteristic points. To test this hypothesis, at the indicated points (Fig. 6), the body surface temperature was measured with the infrared pyrometer TLD-100 (accuracy of measurements - 0.1 °C).

The analysis of the obtained temperature values confirmed the hypothesis and the possibility of primary diagnostics of the vascular system at home. The sharp difference in temperature between some points of the body surface (3–5 °C) or significant asymmetry of the temperature of the left and right side of the body indicates possible pathologies of the vascular system and circulatory disorders. For example, a decrease in the temperature of the fingers of the extremities can be a manifestation of diabetic angiopathy or atherosclerosis.

It is expedient to measure the temperature of the body surface with the help of a pyrometer in an outpatient setting. But this method is not suitable for a moving body or for long-term monitoring. Therefore, in the work, a mobile multichannel digital thermometer-registrar was developed, the structure of which is shown in Fig. 7. This thermometer is developed on the basis of the Atmel microcontroller, using the digital thermometers DS18B20 with the 1-Wire interface. During monitoring, the temperature values (measured by the contact method) are recorded on a Micro-SD card for further processing on a personal computer.

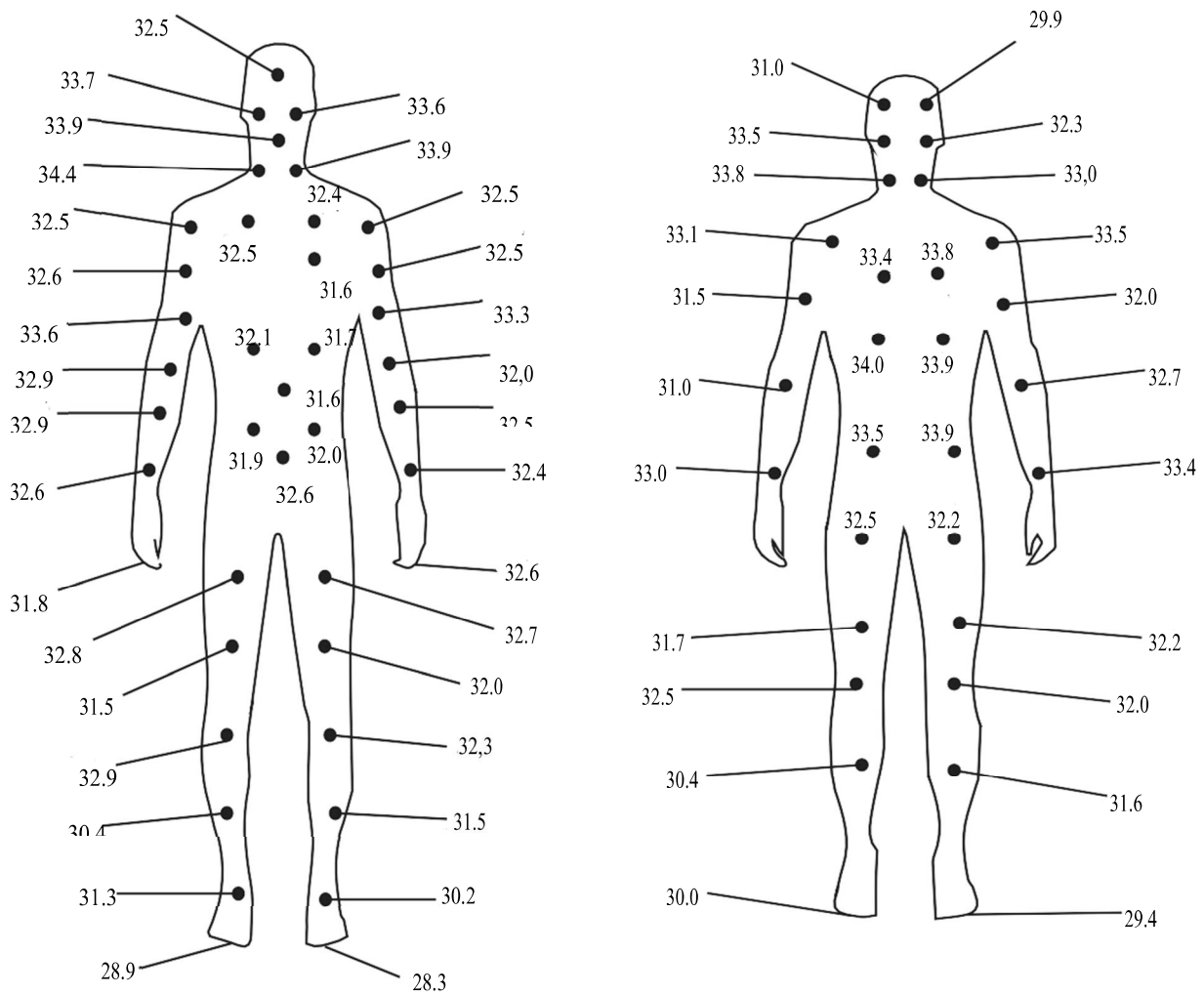

Fig. 6. The points temperature on the patient's body surface (front and rear view)

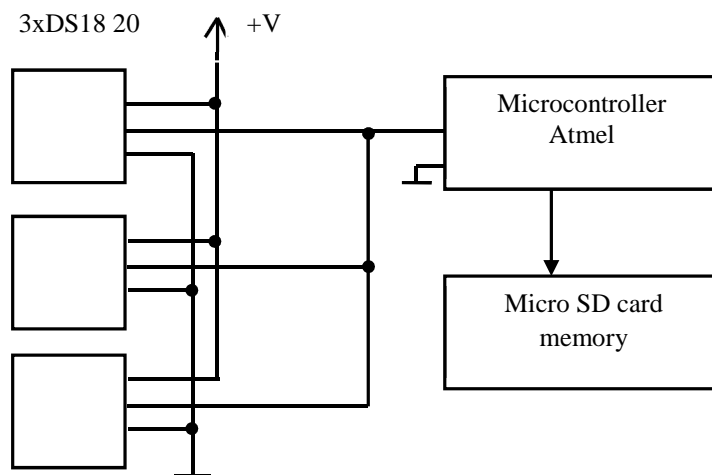

Fig. 7. Block diagram of a mobile multichannel digital thermometer-registrar

The experimental version of the device was implemented on the basis of the digital thermometer-thermostat MP707R (Fig. 8). The graphs of temperature under the armpit and on the fingers of the upper and lower extremities are presented in Fig. 9.

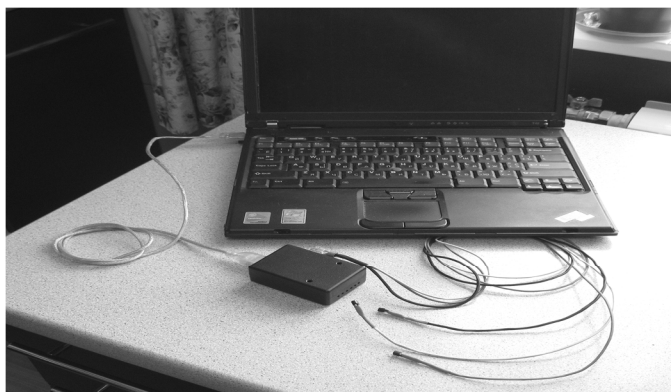

Fig. 8. Experimental variant of the device

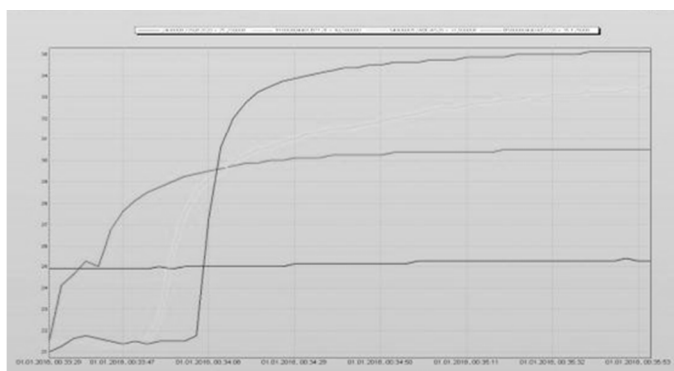

Fig. 9. Graph of temperature under the armpit and on the fingers

Conclusion

The following scientific and practical results were obtained in this work:

1. The development and identification of the model of the diagnostic laboratory and evaluation of its functioning, as a system of mass service, are carried out.
2. The operating characteristics of the diagnostic laboratory are determined and the necessity of developing available means is substantiated for the preliminary diagnostics of cardiovascular diseases at the home condition.
3. Developed hardware and software for the primary computer diagnostics of cardiovascular diseases.
4. Developed means for the primary computer diagnostics of vascular diseases on the basis of analysis of body temperature in the characteristic points.

1. Deitel H. M. "An Introduction to Operating System", Addison-Wesley, 1984.