

6. Тугунов, П. И. Типовые расчеты при проектировании и эксплуатации нефтебаз и нефтепроводов: учебное пособие для вузов [Текст] / П. И. Тугунов, В. Ф. Новоселов, А. А. Коршак, А. М. Шаммазов. - Уфа: ДизайнПолиграфСервис, 2008. – 658 с.
7. Ивченко, Е. Г. Сернистые и высокосернистые нефти Башкирской АССР (Справочная книга) [Текст] / Е. Г. Ивченко, Г. В. Севастьянова. – М. : Государственное научно-техническое издательство нефтяной и горно-топливной литературы, 1963. - 232 с.
8. Мазепа, Б. А. Парафинизация нефтесбросных систем и промышленного оборудования [Текст] / Б. А. Мазепа. – М. : Недра, 1966. - 185 с.
9. Тронов, В. П. Системы нефтегазосбора и гидродинамика основных технологических процессов [Текст] / В. П. Тронов. – Казань : Изд-во «ФЭН», 2002. - 512 с.
10. Полищук, Ю. М., Яценко И. Г. Физико-химические свойства нефтей: статистический анализ пространственных и временных изменений [Текст] / Ю. М. Полищук, И. Г. Яценко. – Новосибирск : Изд-во СО РАН, филиал «Гео», 2004. – 109 с.

УДК 62-854

# RESEARCH WORKFLOW OF VERTICAL AXIS WIND TURBINES BY NUMERICAL EXPERIMENTATION

*В статті наведено результати чисельного моделювання робочого процесу ортогональних вітроподвигунів за допомогою розрахункового комплексу ANSYS CFX. Виконано аналіз адекватності результатів чисельного експерименту, отриманих з використанням різних моделей турбулентності. Шляхом порівняння розрахункових даних та результатів фізичного експерименту доведено, що найбільш адекватні результати забезпечує використання SSG моделі турбулентності*

*Ключові слова: чисельний експеримент, аеродинамічні характеристики, ортогональний вітроподвигун, модель турбулентності, криловий профіль*

*В статье приведены результаты численного моделирования рабочего процесса ортогональных ветродвигателей с помощью расчетного комплекса ANSYS CFX. Выполнен анализ адекватности результатов численного эксперимента, полученных с использованием разных моделей турбулентности. Путем сравнения расчетных данных и результатов физического эксперимента доказано, что наиболее адекватные результаты обеспечивают использование SSG модели турбулентности*

*Ключевые слова: численный эксперимент, аэродинамические характеристики, ортогональный ветродвигатель, модель турбулентности, крыловой профиль*

**V. Lipoviy**

Post graduate student\*

E-mail: vitaliy.lupoviy@gmail.com

**A. Papchenko**

Research associate

E-mail: papchenkoa@mail.ru

\*Department of Applied Hydro- and Aeromechanics

Sumy state university

2 Rimsky-Korsakov Str, Sumy, Ukraine, 40007

## 1. Introduction

Research results of creation of methodology for orthogonal windmills characteristics determination by means of numerical experiment are presented in this paper. Diagrams of integral dependences obtained using different turbulence models are shown, their comparative characteristic is given and choice of proper calculation models is proved.

## 2. Work objective

Creation of methodology for orthogonal windmills aerodynamic characteristic, comparison of obtained data with experimental characteristics and proof of ANSYS CFX software package efficiency for determination of major orthogonal windmills aerodynamic characteristic.

## 3. Problem statement

Determination of major aerodynamic characteristics of orthogonal windmills is connected with specified difficulties. The most accurate method of construction of windmill operational characteristic is full-scale test. But for realization of this method significant material costs are necessary: existence of test model of windmill; existence of installation for axisymmetric air flow with constant velocity creation; usage of measurement technology for gathering values of rotation speed and power on the windmill shaft.

Besides there is range of numerical methods, which are based on pulse and vortex aerodynamic theories. But one of disadvantages of such method is non-accuracy of finite results and it is necessary to test profiles in aerodynamic tunnel to get more accurate results.

Possibility of Navier-Stokes equations solution using software packages occurred by means of microtechnology development. The major theme of this paper is determination

of orthogonal windmills aerodynamic characteristics by means of ANSYS CFX software package.

Nowadays this software package is widely used for modeling and calculation of hydraulic flow parts of pump equipment and shows quite reliable data in practice.

Usage of this method for determination of major characteristics of hydraulic machines gives an opportunity to decrease power inputs for research and manufacture of finite aggregate and to predict working area of installation.

As far as information about implemented numerical experiments for windmills was not found, it was defined to test mentioned software package for windmills calculation and comparison of obtained results with experimental data, derived in the wind-power engineering laboratory in Sumy State University.

Research object – working process of orthogonal windmill [1] (Fig. 1).

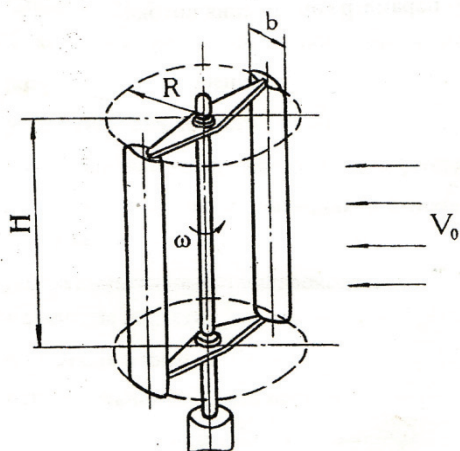

Fig. 1. Orthogonal windmill

One of significant features of orthogonal windmill blades work in air flow is constant change of angles of attack, values and direction of aerodynamic forces on blade along entire path of circular motion.

Even for constant vector of incident flow and inleakage steadiness along blade spread, loads vary according to complex cyclic dependence, which is determined by wind velocity, circular velocities and blade angles, their position relative to flow rate vector. Angles of attack of blades vary cyclic by azimuth angle during windmill rotation.

Theses features of orthogonal windmill work determine algorithm of their major characteristic  $C_p=f(\theta)$  construction. It is necessary to obtain computational points for determination of graphical dependence. Each point is characterized by definite wind energy use coefficient  $C_p$  and specific speed  $\theta$ . Possibilities of ANSYS CFX software package permits to determine torque moment on windmill shaft during analysis of implemented calculation results. Later this value permits to determine wind energy use coefficient. That is why for this research variable initial factor is windmill rotation speed (which determines its specific speed).

Experimental data obtained in the wind-power engineering laboratory in Sumy State University by professor V.M.Kovalenko were accepted as theoretical basis for this paper [2, 3].

Two construction diagrams of rotors with wing-shaped open profiles of KH-4 and KH-6 types were considered for comparison obtained data and for decreasing of accidental result obtaining probability.

Table 1

Comparison of rotors with KH-4 and KH-6 blade profiles

Profile standard size	KH-4	KH-6
Rotor diameter, m	0,3	0,4
Rotor height, m	0,24	0,24
Number of blades	3	3
Blade chord, m	0,05	0,1

4. Methodology of  $C_p=f(\theta)$  dependence construction

It is necessary to determine coordinates of working points of researched windmill for construction of major characteristic of orthogonal windmills  $C_p=f(\theta)$ .

Each point is specified by the value of wind energy use coefficient  $C_p$  for given specific speed  $\theta$ . Value of specific speed  $\theta$  is initial data for calculation. It is determined by rotation speed of windmill, which is numerically specified during windmill research using ANSYS CFX software package.

As far as shaft moment of orthogonal windmill is variable value by azimuth angle of rotor placement, it is necessary to calculate torque moment for different azimuth angles and to average obtained data for working point determination. Results for 12 rotor placements on circular motion path were used to obtain averaged value in this paper. Therefore research was carried out by 30°.

Initial position of rotor is shown in Fig. 2. Torque moment of air flow side effects on the rotor for this placement. Value of this moment recorded in the table.

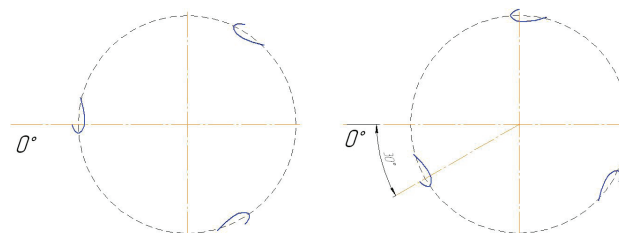

Fig. 2. Position of windmill rotor during calculations

Later rotor rotates relative to rotation axis by 30° and torque moment is determined. Such actions continue until rotor pass entire circle of 360°. At last there is the table with 12 values of torque moment and data is averaged.

Exactly this averaged value of moment determines wind energy use coefficient  $C_{p1}$ , which corresponds to the given coefficient  $\theta_1$  and coordinates of working point are determined.

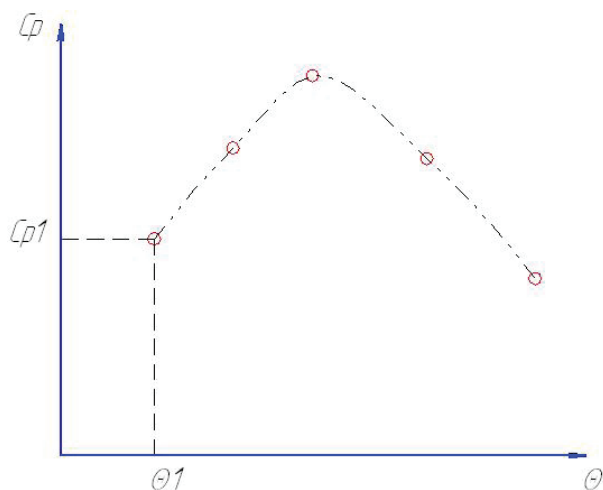

Fig. 3. Construction of graphic dependence  $C_p=f(\theta)$

It is necessary to repeat this algorithm for five points at least to construct total characteristic  $C_p=f(\theta)$ .

### 5. Calculation algorithm

Using of software for liquid flow calculation allows decreasing material and energetic costs on research implementation. This method is rational and reliable if the right methodology of calculation was chosen. It is necessary to use experience and calculation methodologies, confirmed by experimental data to obtain reliable results.

As to orthogonal windmills, there is no scientific basis for calculation of this type aggregates nowadays, that is why it is necessary to analyse and increase knowledge of mentioned problematic sector of renewable energy sources.

Calculation implementation consists of the following stages:

**- construction of computational domain spatial model** – creation of solid 3D model of liquid (air) volume, in which calculation is carried out. In this case the domain is in the form of parallelepiped, which is a volume of air around rotor and in which the part of space for rotor is cut off. Rotor is placed in 1 meter from inlet surface and in 0,5 meter from lateral and outlet surfaces of operational domain to increase influence of solid wall on calculation results. Accuracy of spatial model construction is of great importance because even minimum deviation from initial geometrical dimensions of profile leads to great changes in the further calculation and therefore obtaining non-reliable characteristics of flow. Construction of spatial model was carried out by means of such programs as Compass3D, SolidWorks, AutoCAD.

**- creation of computational grid of separate small elements.** It is necessary to divide computational domain on separate elements as the research is carried out by method of gradual approximation and solution of Navier-Stokes equations. Liquid flow equations will be solved and velocity fields will be defined for each of these elements. Quality of their mutual placement is major factor when grid dividing. Calculation of grid independence was not carried out in this paper, because computational grid with such number of cells that allows carrying out calculation by means of computer was used. Surface names (air flow inlet, outlet, solid walls) are

specified at this stage to simplify end results analysis. Grid construction is implemented by means of ANSYS WORKBENCH software package.

**- determination of boundary conditions** – introduction of initial data for calculation, for example velocity of incident flow, pressure before rotor, rotor speed. Model calculation will be carried out on basis of this data. One of the major factors, which influences on calculation quality is choice of working fluid model and turbulence model for closure of Reynolds equations. Calculation is carried out for air with temperature of 25°C in this case.

**- computer direct calculation** – includes time necessary for computer solution of Navier-Stokes equations in each elementary domain and determination of flow characteristics in each point of computational domain. Time of this stage entirely depends on computer parameters and computational grid dimensions. Necessary and enough condition for engineer calculation is diagram convergence of domain calculation with difference between adjacent calculations of 0,0001.

**- analyse of obtained results** – obtaining of finite parameters of liquid flow and determination of necessary characteristics on basis of these parameters. At this stage amplitude-frequency characteristic of orthogonal windmill is determined, working liquid pattern flow is visualized and as a result reliability of implemented calculation is determined by means of comparison between obtained data and experiment.

### 6. Spatial model of computational domain

Spatial model of computational domain is the volume of liquid around researched object. Taking in to account windmill sizes and influence of bounding walls placement, geometrical sizes of spatial model are: length  $L=1750$  mm, height  $H=1000$  mm, thickness  $B=1000$  mm.

Two principle models of computational domain were chosen for the research: with and without interface between stator and rotor parts (Fig. 4).

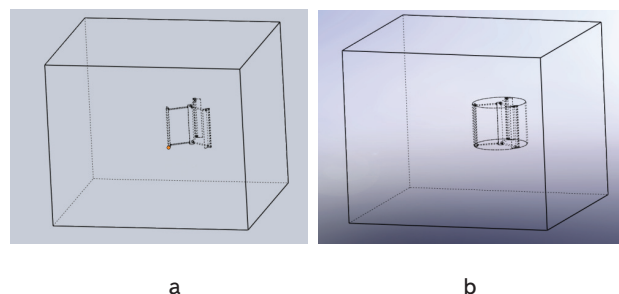

Fig. 4. Spatial model without (a) and with (b) interface between stator and rotor parts

These models differ from number of components. Spatial computational domain without interface consists of one volume of liquid. And model with interface consists of two volumes of liquid. It allows to rotate one part relative to another and to determine shaft torque moment for different azimuth angles of blades arrangement during calculation. Computational domain without interface allows calculation of flow only for fixed rotor placement.

Direct construction of computational domain spatial model was implemented by means of SolidWorks software package.

**7. Construction of computational grid**

Computational grid was constructed by means of ANSYS Workbench. It is unstructured grid, generated of tetrahedrons. Boundary layer was separated during grid construction, it consists of prismatic cells. Total height of prismatic layer equals 1 mm. Number of prisms along layer thickness is 5. Distance from solid wall to the first node of prismatic cell equals  $1,74 \times 10^{-4}$  mm. It allows to obtain variable  $Y^+$  value within the scope of 0,8-1,2.

Total amount of grid elements for KH-4 profile windmill with stationary computational domain equals 1589383 cells, for windmill with non-stationary domain – 1698772.

To obtain more reliable results of research, one size grid was constructed by conjugate cylinders in the domain of future interface.

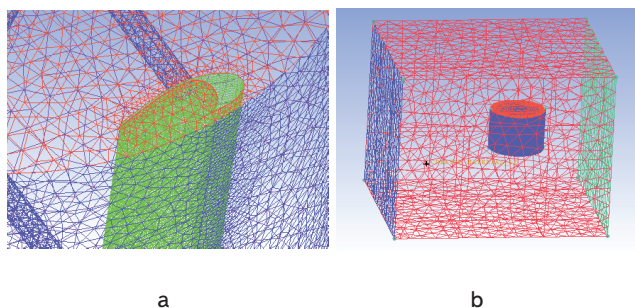

Fig. 5. Computational grid of rotor (a) and stator (b) parts for computational domain with interface KH-4 rotor

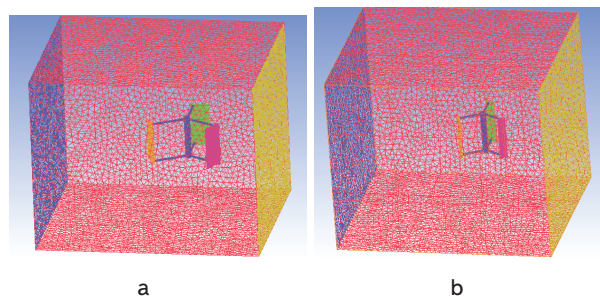

Fig. 6. Computational grid of spatial model KH-4 (a) and KH-6 (b) rotor without interface

**8. Boundary conditions**

Velocity of air incident flow was set at the inlet of computational domains. Its value equals 5,6 m/s. It is the value of averaged flow velocity at the outlet of aerodynamic tunnel during windmills experimental tests in the laboratory of Sumy Applied Physics Institute.

Backflows can occur at the outlet of computational domain. That is why boundary conditions type at the outlet was set as “Opening” with averaged static pressure value of 0,1 MPa.

Roughness of rotor surface was set equal to Ra 1,6 to obtain more accurate data.

Besides rotor speed was set and it was variable for each point of computational characteristic.

**8. Numerical modelling results analysis of orthogonal windmill operation comparison of results obtained using computational domain with and without interface**

The primary task was determination of calculation implementation accuracy dependence on computational domain model. Comparative characteristic of two calculations with similar boundary conditions but with different computational domains (stationary and non-stationary) is shown in the diagram.

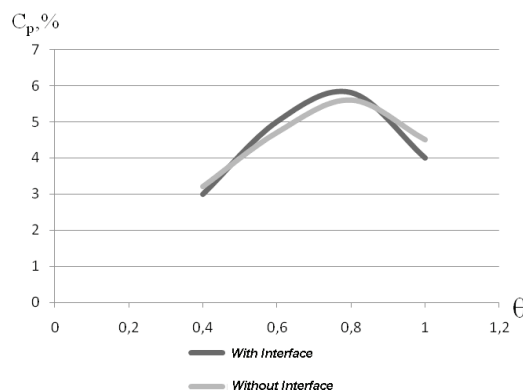

Fig. 7. Comparison of  $C_p=f(\theta)$  characteristics using different types of spatial

From this diagram it is obvious that characteristics are similar. We may draw a conclusion that calculation results do not significantly depend on computational domain model. But time for one computational point determination using stationary computational domain is twice less than using non-stationary domain. That is why the following calculations will be implemented using stationary calculation.

**9. Comparison of  $C_p=f(\theta)$  dependences obtained using different turbulence models**

Initial attempts to obtain orthogonal windmill operational characteristic similar to experimental data using  $k-\epsilon$  turbulence model (the most widespread for hydraulic calculations) didn't show expected results. That is why necessity to study different turbulence models, to take into account their features and to construct dependence  $C_p=f(\theta)$  for windmill using them occurred. Initial calculations were implemented for rotor with KH-6 type blades. Diagrams showing orthogonal windmill characteristics constructed using six turbulence models are presented below:

- K-Epsilon;
- Shear Stress Transport;
- RNG K-Epsilon;
- K-Omega;
- BSL;
- SSG Reynolds Stress.

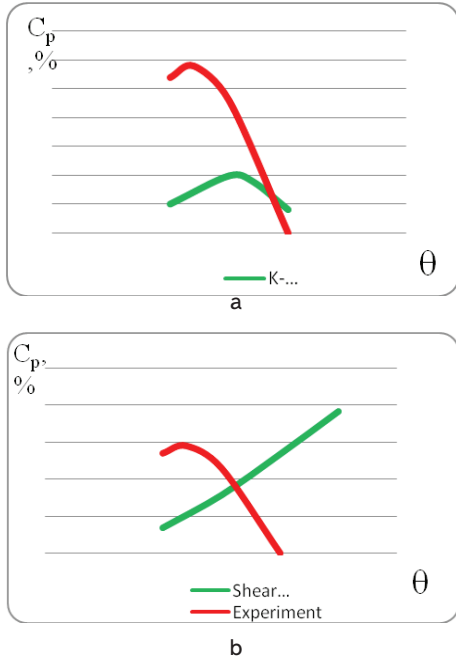

Fig. 8. Comparison of experimental and obtained using K-Epsilon (a) and Shear Stress Transport (b) turbulence model  $C_p=f(\theta)$  characteristics for KH-6 rotor

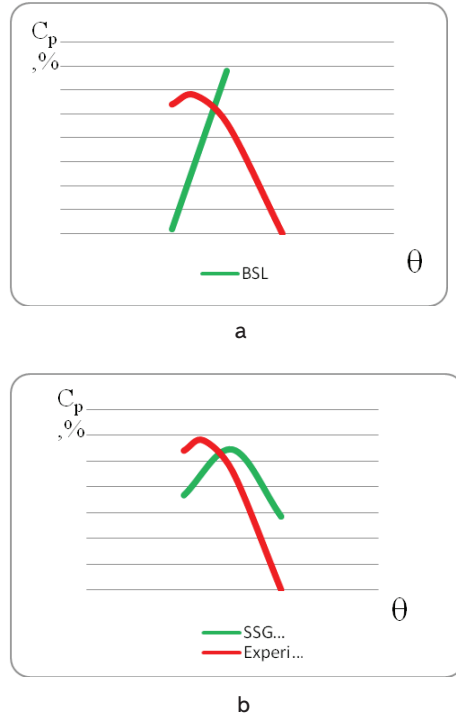

Fig. 10. Comparison of experimental and obtained using BSL (a) and SSG Reynolds Stress (b) turbulence model  $C_p=f(\theta)$  characteristics for KH-6 rotor

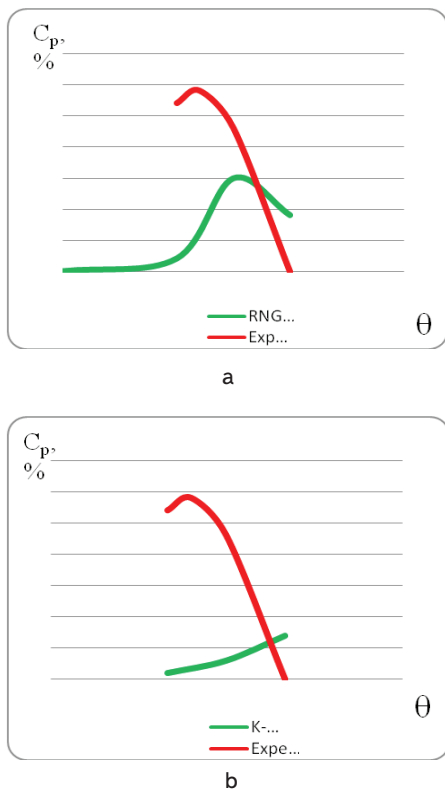

Fig. 9. Comparison of experimental and obtained using RNG K-Epsilon (a) and K-Omega (b) turbulence model  $C_p=f(\theta)$  characteristics for KH-6 rotor

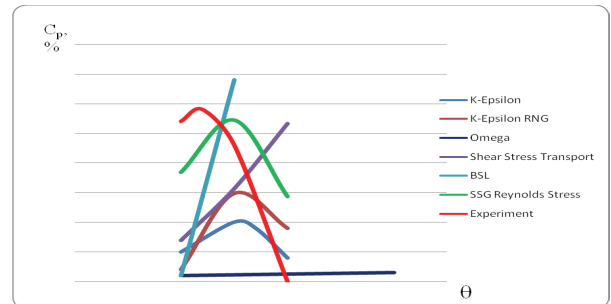

Fig. 11. Comparison of  $C_p=f(\theta)$  characteristics, constructed using different turbulence models

Correcting coefficient  $k$  was introduced for more accurate affinity of characteristics. Characteristic becomes of the following type (Fig. 12) for this coefficient value  $k=0,8$ .

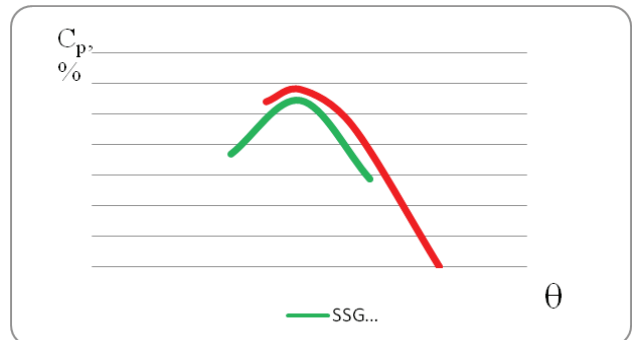

Fig. 12. Comparison of experimental and obtained using SSG Reynolds Stress turbulence model  $C_p=f(\theta)$  characteristics for KN-6 rotor taking into account correcting coefficient

By diagrams analysis we may draw a conclusion that the most similar to experimental is characteristic which was constructed by means of SSG Reynolds Stress turbulence model.

Dependence  $C_p=f(\theta)$  for KH-4 rotor was constructed using SSG Reynolds Stress turbulence model for obtained data accuracy confirmation.

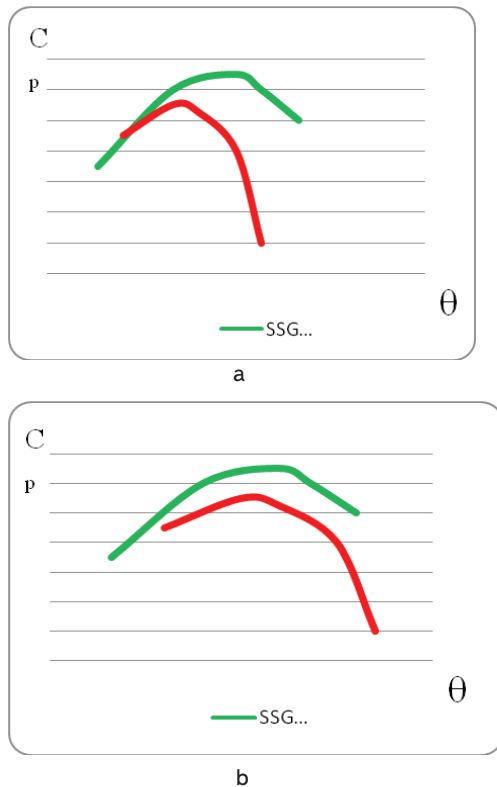

Fig. 13. Comparison of experimental and obtained using SSG Reynolds Stress turbulence model  $C_p=f(\theta)$  characteristics for KH-4 rotor (a), (b) taking into account correcting coefficient

Obtained characteristic becomes of the following type (Fig. 13) when taking into account correcting coefficient.

### 5. Conclusions

Major orthogonal windmills operational characteristics by means of numerical experiment were obtained during this work implementation. Different types of computational domain and different turbulence models were analyzed during creation of the methodology. Comparison of obtained data with experimental dependences gave an opportunity to determine proper type of computational domain and to choose turbulence model, which shows the most similar to experimental results.

By means of implemented research we may draw a conclusion that SSG Reynolds Stress turbulence model allows to determine orthogonal windmill characteristic

accurately, but to get more reliable data and more accurate coordinates of function optimum, correcting coefficient for specific speed  $k=0,8$  is introduced.

### References

1. А.с. 1765493 СССР, МПК F03D3/06. Ветроколесо [Текст] / Коваленко В.М., Волков Н.И., Рожкова Л.Г., Денисенко С.В., Токаренко О.В. (СССР). – 4779414: заявл. 09.01.1990, опубл. 30.09.1992- 4с.
2. А.с. 1733680 СССР, МПК F03D1/06. Лопасть вітроколеса [Текст] / Коваленко В.М., Волков Н.И., Рожкова Л.Г., Бурлака В.Б., Пшик Р.Б. (СССР). – 4776348: заявл. 03.01.1990, опубл. 15.05.1992, Бюл. № 5. – 2 с.
3. Совершенствование аэродинамических форм и аэродинамические способы управления вращением роторов вертикально-осевых ветроустановок [Текст]: отчет о НИР (промежуточ.) / СумГУ: рук. Коваленко В.М. – Сумы, 1997. – 81с.
4. Волков, М.И. Аэродинаміка ортогональних вітродвигунів (деякі математичні моделі та їх чисельна реалізація) [Текст] / Волков М.И. – Суми: ВВП «Мрія-1»ЛТД, 1996.-198с.
5. Шевченко, Ю.В., Методика расчета аэродинамических характеристик быстроходных ветродвигателей [Текст] / Шевченко Ю.В., Ефремов Н.Н., Халай Ю.Л. – К.: 1988.
6. Ляхтер, В.М. Аэродинамика ортогональных ветродвигателей [Текст] / Ляхтер В.М., Шполянский Ю.Б. // Сб.науч.тр. Гидропроекта, - 1988, вып 129, С. 113-127.
7. Гончаренко, С.В. Численное моделирование работы ветроэнергетической установки с вертикальной осью вращения [Текст] / Гончаренко С.В. // Сб. науч. тр. «Математические методы расчета гидрогазодинамических течений» - Днепропетровск, 1990, С. 54-62.
8. Волков, Н.И. Расчет обтекания вращающихся круговых решеток профилей [Текст] / Волков Н.И // Труды VIII междуна. науч. конф. «Насосы -96» - Сумы, 1996, т.1, С. 246-253.
9. Волков, Н.И. Исследование аэродинамики ортогональных ветродвигателей на базе математических моделей [Текст] / Волков Н.И. // тез. докл. научн.-техн. конф. «Гидромеханика в инженерной практике». – К.: 1996, с.11.
10. Волков, Н.И. Математические модели течений в ортогональных ветродвигателях [Текст]/ Волков Н.И.// Тез. докл. X всерос. межвуз. научн.-техн. конф. «Газотурбинные и комбинированные установки и двигатели», – М.: ГИИТБ, 1996, с. 42-42.