

Проблема забезпечення працездатності деталей і вузлів автомобілів є однією з актуальних сучасного автомобілебудування. Більшість деталей автомобілів відчують циклічні навантаження, що призводять до руйнування матеріалів. Тому одним з важливих факторів, що впливає на працездатність виробів, є втомна міцність матеріалу. В роботі проведено аналіз існуючих методик втомних випробувань, представлені їхні переваги і недоліки. Розроблено методик проведення іспитів з втомленості листових автомобільних матеріалів. Її суть полягає в тому, що вона дозволяє вивчати опір втомного руйнування листових металевих матеріалів за схемою чистого вигину в одній площині. Ця схема максимально наближена до умов реального навантаження корпусних елементів конструкції автомобіля. Результати дослідження втомної міцності, отримані реалізацією цієї методики, дають можливість вивчати кінетику процесу руйнування, фіксувати початок макроруйнування, швидкість росту тріщини і, як наслідок, ремонтпридатність конструкції.

Порівняльні випробування дозволяють визначити матеріал, який найбільшою мірою відповідає експлуатаційним вимогам і забезпечує зниження аварійності металоконструкцій автомобіля.

В роботі отримані важливі характеристики опору втомного руйнування ряду автомобільних конструкційних сталей 08 кп і 20 кп: довговічність до повного руйнування, межа витривалості, тривалість періоду до зародження втомних тріщин і швидкість їх подальшого розвитку та, як наслідок, ремонтпридатність конструкції. Так, наприклад, у сталі 08 кп число циклів до повного руйнування (262000 циклів) і період до зародження втомної тріщини (82000 циклів) більше, а швидкість її подальшого зростання ($5.38 \cdot 10^{-5}$ мм/цикл), ніж у сталі 20 кп (174000, 68000 циклів і $8.86 \cdot 10^{-5}$ мм/цикл, відповідно). Хоча ці параметри отримані при більшому (265 МПа) напруженні для сталі 08 кп проти лише 235 МПа для сталі 20 кп. Це обумовлює експлуатаційне перевагу в процесі конструювання автомобіля вибору сталі 08 кп проти сталі 20 кп.

Отримані дані дозволяють на стадії технічного обслуговування автомобіля запобігти руйнуванню елементів конструкції і деталей під дією циклічних навантажень і, як наслідок, підвищити безпеку експлуатації автомобіля, знизити витрати на ремонт.

Ключові слова: втомні випробування, циклічна довговічність, автомобільні конструкційні матеріали, поточний прогин зразка

INFLUENCE OF THE ALLOY COMPOSITION ON DETERMINING THE MILLESIMAL FINENESS OF GOLD BY X-RAY FLUORESCENT AND ASSAY ANALYSIS

G. Pachurin

Doctor of Technical Sciences*

D. Goncharova**

A. Filippov

PhD*

S. Shevchenko

PhD****

M. Mukhina

PhD****

E-mail: mariyamuhina@yandex.ru

N. Kuzmin

Doctor of Technical Sciences**

V. Pachurin

Executive Director

LLC "NAU standard"

Gaugelya str., 21/59, Nizhny Novgorod, Russia, 603139

Yu. Matveyev

Doctor of Technical Sciences

Volga state university of water transport

Nesterova str., 5, Nizhny Novgorod, Russia, 603950

L. Kutepova

PhD****

Zh. Smirnova

PhD****

*Department of Industrial Safety, Ecology and Chemistry***

Department of Automobile Transport*

***Nizhny Novgorod State Technical

University named after R. A. Alekseev

Minina str., 24, Nizhny Novgorod, Russia, 603950

****Department of Technology Service and

Technological Education

Minin Nizhny Novgorod State Pedagogical University

Ulyanova str., 1, Nizhny Novgorod, Russia, 603002

1. Introduction

The major part of all types of steel structure failure are of fatigue nature [1]. In this regard, the problem of

ensuring the necessary performance characteristics of the car parts and elements is a priority direction of modern science and one of the most important tasks of the automotive industry.

The operating parameters of the structural materials, designated for manufacturing of the automotive metal parts, are formed at all the stages of metal conversion: from the selection of charging materials for metal smelting until obtaining of the finished parts [2, 3]. In addition to other factors, the body frame, as well as other elements of the car structure, is also subjected; to fatigue failure in the process of operation, which may lead to a decrease of the working efficiency of the part, and to the irrecoverable consequences and even to loss of lives.

The reason of the necessity to increase the fatigue strength is also a high cost of the metal parts. That is why the performing of fatigue tests in order to reduce metal consumption of the parts, to develop new methods of metal treatment, and to select other material is very important in the modern automotive industry.

At present, metal parts from different structural materials are used in the automotive industry, obtained by different types and regimes of process treatment [4–6]. The main factors which influence on their operating properties, except for the nature of the material, are structural status and surface quality [7, 8], which to a great extent are determined by the conditions of their manufacturing process. These factors, as stress risers, contribute to the initiation and propagation of fatigue cracks. Under cyclic loading in the surface layers of the metal, all processes associated with the nucleation of fatigue cracks go ahead and the entire structural damage is initiated near the surface [9, 10].

In the automotive industry and machine-building industry, stamped sheet low-carbon structural steels are widely used. However, the data on the impact of types and regimes of the process treatment on mechanical properties at different temperatures are limited and scattered. This predetermines the necessity of finding optimal structural decisions and using technologies, which provide high operating characteristics of parts and structures. So, the goal of increasing of the cyclic reliability of automotive parts with possible reduction of their metal consumption taking into consideration the methods of their manufacturing is rather challenging. The reaching of this goal assumes study of the kinetics of the fatigue fracture process of the car materials at different schemes of loads and temperatures, fixing the beginning of fatigue crack nucleation and the rate of crack growth. This will enable to select the material, which corresponds to the operating requirements, and, as a consequence, to prevent the failure of structural elements and parts at cyclic loads, and to reduce the cost of car repair.

2. Literature review and problem statement

In paper [3], it has been shown that, in order to assess the performance of metal products, in addition to static failure parameters, it is necessary to know the characteristics of fatigue strength, which are significantly dependent on the types and modes of technological treatment. It is noted [4] that it is important not only to develop the technological process of manufacturing of a car element, but also to take into account the totality of all factors that affect service life in the process of subsequent operation [5].

Various types of testing machines are used to study the fatigue properties of samples from structural materials [9]. According to [11], the requirements for the choice of parameters of fatigue machines and their dynamic scheme

are determined by test methods, metrology, reliability and efficiency. These properties are largely determined by the dynamic characteristics of the machines and test samples.

Depending on the loads created, fatigue equipment can be subdivided into machines for torsion test samples, bending test and compression test samples. In this case, the sample can be subjected to a force at a constant amplitude (with controlled loading) or with a constant amplitude of deformation (with controlled deformation). In the first case, the failure after the initiation of the first crack is observed earlier [12] than in the second case, since the open area of the sample decreases with increasing size of the fatigue crack and, as a result, is affected by a higher stress [13]. The basic schemes and principles for creating and calculating fatigue machines are described in detail in the special literature [9].

As seen from the review, not all modern fatigue testing machines are sufficiently automated and, as a rule, do not provide control of accelerated testing processes. They can not always meet the requirements of the researcher and are often large-sized, difficult to maintain and quite expensive [1]. Thus, at the present time there are no relatively small and inexpensive test fatigue machines with fixation of changes in the current deflection under cyclic loading. However, it is necessary to study the kinetics of the fracture process, register the beginning of macrofracture, crack growth rate and, as a result, optimize the choice of competing materials and maintainability of the structure.

3. The aim and objectives of the study

The aim of the paper is to develop a method of fatigue testing of flat samples of automotive structural materials using software-hardware compact desktop complex EMU-5-PC (electromagnetic accelerator).

To achieve it, the following objectives were set:

- to modernize the EMU-5 installation;
- to conduct research and development of fatigue tests of flat samples from 08 kp and 20kp steels, construct their fatigue curves and curves of changes of current deflection;
- to determine the characteristics of fatigue strength of 08kp and 20kp steels.

4. Software-hardware compact desktop complex EMU-5-PK for fatigue testing

The complex includes a desktop instrument-hardware automated EMU-5 installation and a personal computer with a built-in DAC-ADC card and software. The complex is designed for carrying out standard, accelerated, and special fatigue tests of flat samples and structural elements, as well as for growing fatigue cracks.

The loading device of the complex contains a universal electromagnetic force actuator, allowing non-contact loading of the sample with force or moment. The design of the loading device provides fatigue testing according to the scheme of pure bending in one plane.

The complex operates in the autoresonance mode, that is, the excitation system automatically tracks own frequency of the sample. The required amplitude of oscillations is also maintained automatically at a pre-programmed level. There is an automatic shutdown of the complex at any stage of the fatigue crack propagation in the sample. The measurement

system controls the amplitude, frequency and number of loading cycles of the sample. Registration of the measured parameters is carried out in digital form with their output on the front panel of the instrumentation unit of the EMU-5 installation and on the PC monitor screen. Autonomous operation of the EMU-5 installation is possible without connecting to a PC.

The advantages of this complex include:

- small dimensions and weight;
- no rotating parts;
- quietness and complete ecological cleanness;
- simplicity of maintenance;
- low power consumption and cost.

The disadvantages of EMU-5 include:

- the need for constant visual monitoring of the test;
- low informational content of experimental data;
- manual adjustment of loading parameters during accelerated fatigue tests.

In order to eliminate these disadvantages, a PS/AT-type PC is connected to the complex via a discrete-analog processor.

The EmuLab program together with the data files provides the simplicity of the input /output operations of the information: selection of the test method, input of the necessary basic data required for each method. In addition, it also provides the output of research results presented in a convenient form in text files with the possibility of viewing and printing them. Moreover, some data are presented in graphical format.

The hardware-software compact complex EMU-5-PC for testing materials for fatigue is an electromagnetic device for fatigue testing according to the scheme of pure bending in one plane (Fig. 1).

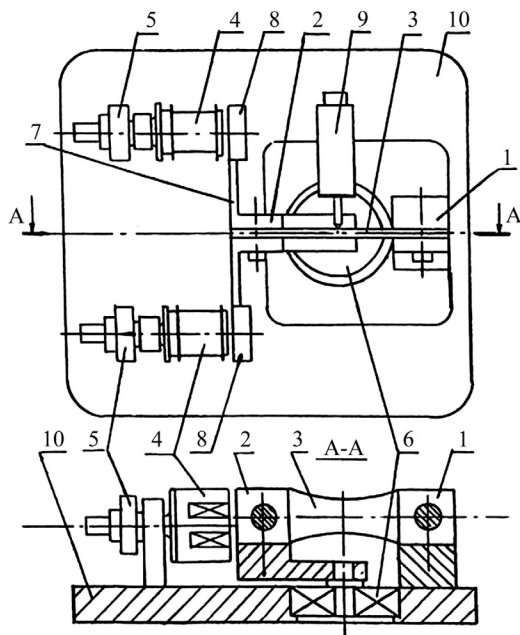

Fig. 1. Device for fatigue tests: 1 – fixed catch; 2 – movable catch, 3 – sample, 4 – electromagnet, 5 – screw mechanisms, 6 – bearing unit, 7 – transverse beam, 8 – anchors, 9 – transverse beam, 10 – base plate

This device contains a fixed 1 and a movable 2 catches, to which the sample 3 is attached with the help of bolts. As

a force actuator, two electromagnets 4, located on the screw mechanisms 5 are used. On the movable catch 2, the axis of rotation of which is located in the bearing joint 6, a traverse beam 9 with anchors 8 is installed. Screw mechanisms are used to set the required clearance between the anchors and electromagnets, depending on the size of the sample and the amplitude of its oscillations. The measurement of the oscillation amplitude of the sample is produced by an induction sensor 9, the movable element of which is pressed against the sample by a spring. All installation units are fixed on the foundation 10.

The difference from other installations is that the traverse beam 7 is made in the form of a two-arm lever and mounted on an eccentric swivel pad, the axis of which is perpendicular to the axis of the sample and intersects it in the middle of the working section. In this case, the moving masses of the device make a rotational motion, as a result of which only the moment of inertia forces affects the sample, and the transverse inertia forces are zero. The rotation of the traverse beam 9, made in the form of a two-arm lever, together with a movable catch 2 relative to the axis passing strictly through the middle of the working section of the sample, ensures its bending along the arc of the circle. This eliminates the longitudinal normal and transverse tangential stresses, and the bending stresses in any section of the sample will be the same.

Consequently, the fatigue tests of the sample will be carried out according to the scheme of pure bending in one plane. The installation provides an induction sensor for measuring the amplitude of loading.

5. Methods of fatigue testing of plane samples of automobile structural materials

With rigid requirements to reduction in metal consumption of automobiles and technical equipment, sometimes it is difficult to avoid initiation of fatigue cracks on essential parts. But in some materials, they can appear comparatively early and the most part of their "life" components operate with cracks. So, for full performance evaluation of components, it is necessary to know not only the parameters of fatigue strength, but also have maximum information about failure on all stages of their fatigue failure: stage of crack initiation, propagation till total failure.

In connection with this, important characteristics of material behavior with cyclic loading are curves of cyclic hardening (softening) that have an effect on curves of change of current bending deflection during fatigue testing [14, 15]. Curves of cycling hardening (softening) reflect processes of structural variations that happen in the metal with fatigue.

In some materials, for example, normalized structural steels, under cyclic loading and amplitude more than macroscopic yield strength, continuous cyclic hardening is observed. However, continuous cyclic softening is customary for high-impact and cold-shaping metallic materials with stress amplitudes of the yield strength. Continuous softening with the following cyclic hardening is customary for normalized structural steels provided that the amount of applied load is within macroscopic yield strength. Basically, hardening is a preliminary stage of material fatigue, after which with definite alternate stress values and definite number of cycles, loosening appears that ends with initiation and propagation of fatigue failure.

Using the curves, it is possible to determine the moment of fatigue crack initiation (point “b,” Fig. 2), which leads to deflection increasing, and also estimate its propagation rate. Deflection of the cylindrical sample with fatigue has three sections: 1 – decreasing for annealed or increasing for cold rolled materials; 2 – deflection stabilizing and 3 – its sharp increasing due to failure.

In addition, deflection increasing of the sample after the stabilizing stage corresponds to the moment of initiation (Fig. 2, point b) of the macro-crack on its surface with the length of ~1.0 mm.

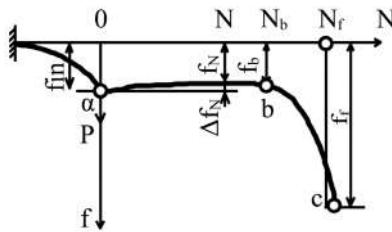

Fig. 2. Curve of sample deflection measurement [8]:
N_f – number of cycles to sample failure; *f_{in}* – initial deflection value; *f_f* – deflection in the moment of failure; *f_N* – current deflection; Δf_N – alteration of current deflection; *b* – point that corresponds to the moment of fatigue crack initiation; (*ab*) – section of the deflection curve before crack initiation; (*b-c*) – section of crack propagation; *f_b* – deflection in the moment of fatigue crack initiation

Such information is especially important for cyclic loading of materials during testing when direct observation of the sample surface is problematic. Therefore, the decision was made to modernize EMU-5. Modernization consisted in the installation of the dial gauge for correct measurement of the amplitude of the sample loading (Fig. 3.)

The hardware and software system allows performing fatigue testing automatically. Equipping test machines with automation devices enables to intensify the process of mechanical test and to increase the quality of the obtained results. Complexity in this case is in providing necessary modes of loading, especially with continuous growing amplitude of stresses and with block loading. Application of automated complexes with close-cycle allows realization of process control of fatigue tests. Using computing machines allows realization of virtually any load program. For example, they allow displaying results of tests in real-time mode, automation of the processing of the attained results and presentation of them in an appropriate form.

EMU-5 electromagnetic device for fatigue testing has two levels of automation. The first level ensures supporting of the autoresonant mode and set amplitude of oscillation. The second level allows carrying out tests with any program of loading, operation control and processing of test results. The hardware system of EMU-5 contains two feedback channels: frequency channel and oscillation amplitude channel.

The frequency feedback channel ensures operation in the autoresonant mode, in other words, the control system traces and supports automatically the natural frequency of the sample regardless of its shape, size and material. Also the required amplitude of oscillation is supported automatically on the set level within the accuracy of 1 μm (second feedback channel). The block diagram of the EMU-5 automated complex is provided in Fig. 4.

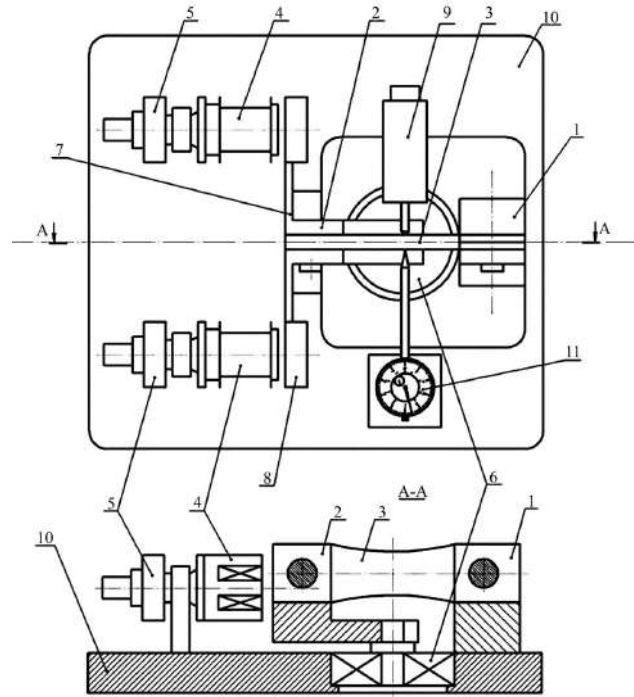

Fig. 3. Modernized EMU-5 fatigue electromagnetic device:
 1 – fixed catch; 2 – movable catch; 3 – sample;
 4 – electromagnets; 5 – screw mechanisms; 6 – bearing unit; 7 – reverser; 8 – anchor; 9 – induction sensor; 10 – base plate; 11 – dial gauge

The strain gauge signal 2 of the sample moving 1 is fit in the block 3 to the symmetrical state, and as a result, excluding the need for zero adjustment of the gauge.

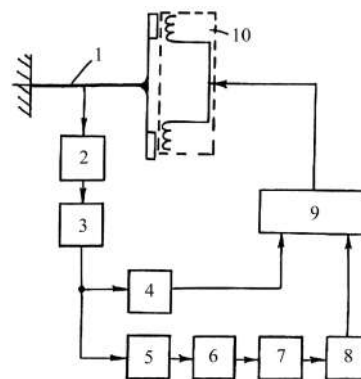

Fig. 4. Block diagram of the EMU-5 automated complex

The phase changer 4 in the frequency feedback circuit supports an optimized phase balance between the electromagnetic excitation system 10 and the mechanical oscillating system with the sample 1. The feedback circuit for the oscillation amplitude of the sample includes the peak detector 5, comparator 6, setter of the necessary amplitude level (control law) 7 and control signal forming block 8. Both feedback signals from block 4 and 8 output are transmitted to the amplifier 9 and form there a powerful control signal, which is sent to the coils of the electromagnetic excitation system 10.

The setting of the control law of in the EMU-5 device is done in two ways: manual with handles “Amplitude. Coarsely” and “Amplitude. Finely” and also using a computing machine. In the latter case, the EMU-5 device is a

fully automated hardware-software system, allowing fatigue testing by any law of stress changes in the sample over time: standard, accelerated, block and others.

Study and practicing of methods of fatigue testing of plane samples of automobile structural materials are conducted based on the car frame GAZ-3302. 20kp and 08kp steels are used for automobile frame structures. Chemical composition and mechanical characteristics of the studied steels are represented in Table 1 and 2.

Table 1

Chemical composition of 08kp and 20kp steels

Steel grade	Mass content of elements, %							
	C	Si	Mn	P	S	Cr	Ni	Cu
08kp	0.05–0.12	No more than 0.03	0.25–0.50	0.030	0.035	0.10	0.30	0.30
20kp	0.17–0.24	No more than 0.07	0.25–0.50	0.030	0.035	0.25	0.30	0.30

Table 2

Mechanical characteristics of 08kp and 20kp steels

Steel grade	Mechanical characteristics, not less than				
	$\sigma_T, N/mm^2$	σ_B, MPa	$\delta_5, \%$	$\psi, \%$	$E \cdot 10^5, MPa$
08	196	320	33	60	2.12
20	245	410	25	55	2.03

The study of fatigue crack surfaces of the samples was conducted using an optical comparator with a tenfold increase, and also photographs with an increase of up to 7 times.

6. Results of kinetics study of fatigue failure of steel sheet materials

Fig. 5 represents the fatigue curve in the coordinates “stress amplitude – number of cycles to destruction”, its equation and value of the correlation coefficient for 08kp steel. The fatigue limit is defined by the Lokati method ($\sigma_{-1} = 176$ MPa).

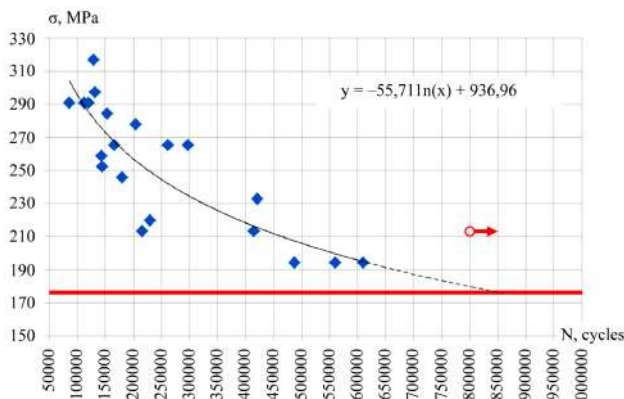

Fig. 5. Fatigue curve for 08kp steel in $\sigma-N$ coordinates. Coefficient of correlation $r = -0.829$

Fig. 6 represents the fatigue curve in the coordinates “stress amplitude – number of cycles to failure”, its equa-

tion and value of the correlation coefficient for 20 kp steel. The fatigue limit is also defined by the Lokati method ($\sigma_{-1} = 190$ MPa).

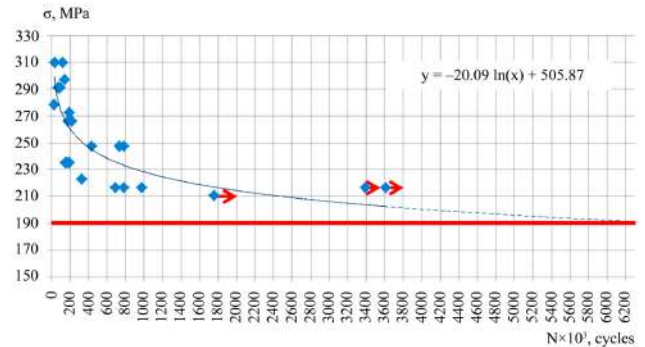

Fig. 6. Fatigue curve for 20 kp steel in $\sigma-N$ coordinates. Coefficient of correlation $r = -0.781$

Curves of the changing of the samples current deflection in the process of cyclic loading were developed in $\Delta f - N$ coordinates. Curves of changing are a reflection of the process of material fatigue from fatigue crack initiation till the total destruction failure of the sample. As an example, the curves of deflection changing with fatigue of the samples from 08kp (Fig. 7) and 20kp (Fig. 8.) steels are provided.

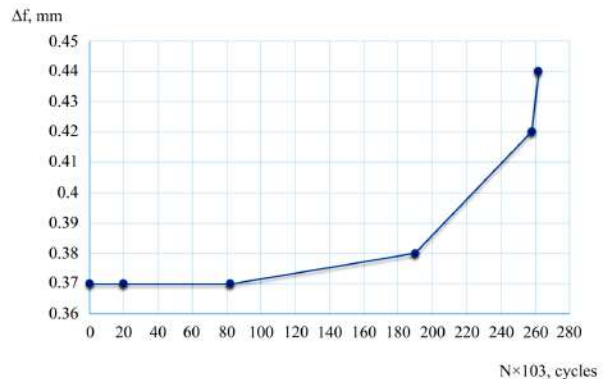

Fig. 7. Curve of changing of current sample deflection from 08kp steel in the process of cyclic loading $\sigma = 265$ MPa; plane bending with the frequency of 27 Hz; $N_f = 262.000$ cycles

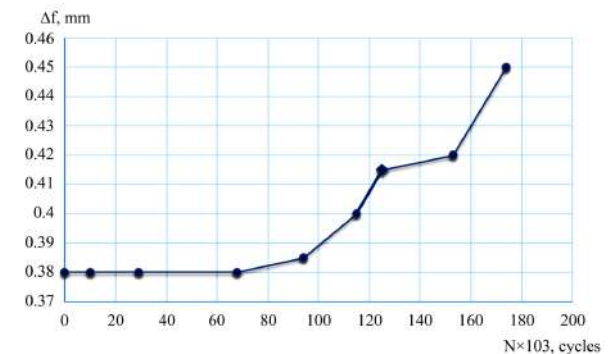

Fig. 8. Curve of changing of current sample deflection from 20 kp steel in the process of cyclic loading $\sigma = 235.2$ MPa; plane bending with the frequency of 27 Hz; $N_f = 174,000$ cycles

The horizontal part on the curve of current deflection testifies that the sample is not destroyed and keeps its

strength characteristics. The inflection point testifies about the initiation of the growing fatigue macrocrack and testifies about sample failure on the last section of the curve of sharp amplitude increase.

Fig. 9 represents photographs of the surface of the fatigue sample from 08kp steel after cyclic loading, at $\sigma=265$ MPa ($N_f=262,000$ cycles).

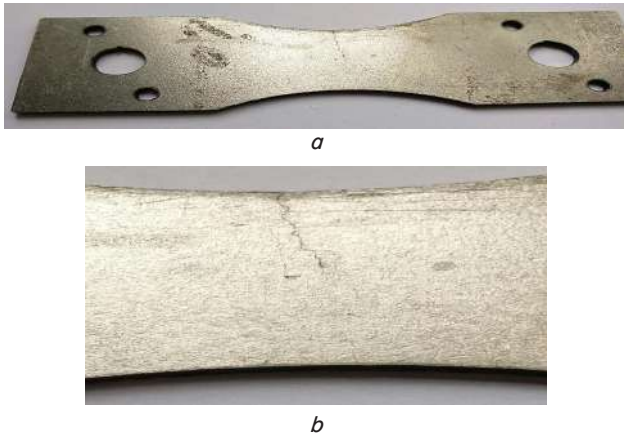

Fig. 9 Fatigue crack on the surface of the sample from 08kp steel, at $\sigma=265$ MPa ($N_f=262,000$ loading cycles): a – general view; b – crack

Fig. 10 represents photographs of the surface of the fatigue sample from 20kp steel after cyclic loading, at $\sigma=235.2$ MPa ($N_f=174,000$ cycles).

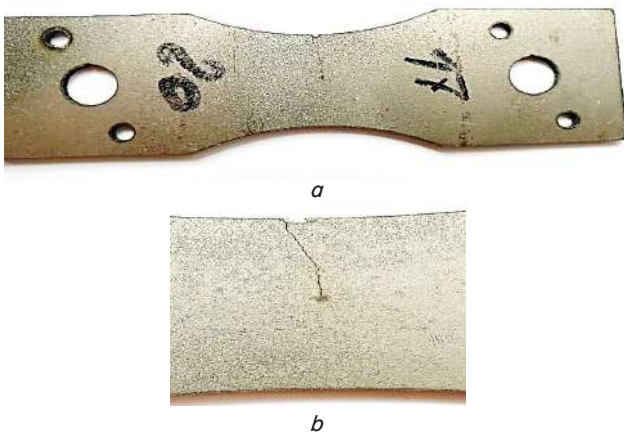

Fig. 10 Fatigue crack on the surface of the sample from 20kp steel, at $\sigma=235.2$ MPa ($N_f=174,000$ loading cycles): a – general view; b – crack

Correlations of the curves parameters of the sample current deflection in the process of cyclic loading with observation of the moment of initiation of the fatigue crack and fixation of its further propagation are represented in Table 3.

Analysis of the obtained results shows that the fatigue limit by the Lokati method for 20kp steel is a little bit higher than for 08kp steel. However, the fatigue macrocrack is initiated earlier in 08kp steel and grows with a much lower rate. Therefore, 08kp steel can be more preferable for essential parts than 20kp steel, because the opportunity for fatigue damage detection during maintenance is high, which decreases the probability of car accidents.

7. Discussion of the results of the study of sheet automobile materials

As a result of the study of fatigue failure of plane samples of 08kp and 20kp steels, total cyclic-life, period of initiation of fatigue cracks and rates of their further propagation were defined.

The obtained characteristics of fatigue strength for the studied structural steels showed preference of 08kp steel against 20kp steel during automobile construction. For example, 08kp steel showed better results than 20kp steel, so the number of cycles to total failure (08kp – $2.62 \cdot 10^5$, 20kp – $1.74 \cdot 10^5$) and the period till fatigue crack initiation (08kp – $8.2 \cdot 10^4$, 20kp – $6.8 \cdot 10^4$) are greater, and the rate of further crack growth (08kp – $5.38 \cdot 10^{-5}$ mm/cycle, 20kp – $8.86 \cdot 10^{-5}$ mm/cycle) is lower. Although these parameters are obtained with the stress of 265 MPa for 08kp steel and 235 MPa for 20kp steel.

The choice of 08kp steel improves the safety of the automobile, level of its maintenance and cuts expenses for repair, because based on the obtained data, the failure of structural elements and parts that are in operation under cyclic loading can be prevented at the stage of maintenance.

The results of the study can be used in other fields of science and manufacturing, where evaluation of the behavior of sheet materials in operation is needed.

In the future, it is planned to conduct monitoring of kinetics of fatigue failure of materials using digital analogs.

8. Conclusions

1. Modernization of the EMU-5 device for fatigue testing of plane samples was made. It consisted in the installation of the dial gauge for correct measurement of the amplitude of sample loading. This allows fixing changes of current sample deflection with fatigue, so the possibility emerges for studying the kinetics of failure process, fixing the beginning of macrofailure, crack growth rate, and consequently optimizing the choice of competing materials and maintainability of the structure.

2. The studies of 08kp and 20kp sheet steels widely used in automobile manufacturing were conducted, and curves of fatigue and curves of changing of current samples deflection were plotted.

Table 3

Parameters of fatigue failure of 08kp and 20kp automobile steels

Material	N_f , cycle.	$n_{cr.in.}$, cycle.	$n_{cr.gr.}$, cycle.	$l_{cr.}$, mm	$V_{m.cr.}$, mm/cycle	$n_{cr.in.}$, % from N_f	$n_{cr.gr.}$, % from N_f	σ_{-1} , MPa
08kp steel	262,000	82,000	180,000	9.8	$5.38 \cdot 10^{-5}$	31.3	68.7	176
20kp steel	174,000	68,000	106,000	9.4	$8.86 \cdot 10^{-5}$	39.8	60.2	190

Notes: N_f – total number of cycles to sample failure; $n_{cr.in.}$ – number of cycles to fatigue crack initiation; $n_{cr.gr.}$ – number of cycles of fatigue crack growth; $l_{cr.}$ – total fatigue crack length; $V_{m.cr.}$ – medium fatigue crack growth rate; $n_{cr.in.}$ – portion of life to fatigue crack initiation from life to total sample failure; $n_{cr.gr.}$ – portion of life of fatigue crack growth from life to total sample failure; σ_{-1} – fatigue limit by the Lokati method

3. Characteristics of fatigue strength of these steels were obtained: service life to total failure, length of the period till fatigue cracks initiation, growth rate, which allows making a reasonable choice the material on the design stage of the automobile and enhancing its maintainability.

As a result, the implemented methods of fatigue testing of plane samples of automobile structural materials allow

drawing conclusions about the fatigue strength of plane samples of automobile structural materials of 08kp and 20kp steels. Based on the obtained data, an optimal choice of materials can be made on the construction stage, and on the maintenance stage, failure of structural elements and parts that are in operation under cyclic loading can be prevented.

References

1. Terent'ev V. F. *Ustalost' vysokoprochnykh metallicheskih materialov*. Moscow: IMET RAN – CIAM, 2013. 515 p.
2. Bunatyan G. V. *Krepezhnye izdeliya. Perspektivy – v konsolidacii* // *Metizy*. 2010. Issue 01 (22). P. 12–15.
3. Low-Cost Treatment of Rolled Products Used to Make Long High-Strength Bolts / Filippov A. A., Pachurin G. V., Naumov V. I., Kuz'min N. A. // *Metallurgist*. 2016. Vol. 59, Issue 9-10. P. 810–817. doi: <https://doi.org/10.1007/s11015-016-0177-y>
4. Galkin V. V. *Strukturno-deformatsionnaya ocenka uprochneniya metalla v mnogooperatsionnykh processah holodnogo deformirovaniya* // *Uprochnyayushchie tekhnologii i pokrytiya*. 2014. Issue 8. P. 13–20.
5. The Factor of Structure and Mechanical Properties in the Production of Critical Fixing Hardware 38XA / Pachurin G. V., Shevchenko S. M., Mukhina M. V., Kutepova L. I., Smirnova J. V. // *Tribology in Industry*. 2016. Vol. 38, Issue 3. P. 385–391.
6. Pachurin G. V., Vlasov V. A. *Mechanical Properties of Sheet Structural Steels at Operating Temperatures* // *Metal Science and Heat Treatment*. 2014. Vol. 56, Issue 3-4. P. 219–223. doi: <https://doi.org/10.1007/s11041-014-9735-8>
7. Galkin V. V. *K voprosu mikrostrukturnoy ocenki raspredeleniya plasticheskikh deformatsiy metalla holodno-vysazhennykh krepezhnykh izdeliy* // *Kuznechno-shtampovochnoe proizvodstvo. Obrabotka materialov davleniem*. 2014. Issue 8. P. 11–14.
8. Gurov V. D., Vladimirov A. G. *Uluchshenie kachestva krepezhnykh izdeliy i snizhenie rashkoda metalla pri proizvodstve* // *Stal'*. 2005. Issue 12. P. 52–54.
9. *Metallovedenie*. Vol. 1 / Novikov I. I., Zolotarevskiy V. S., Portnoy V. K., Belov N. A., Livanov D. V., Medvedeva S. V. et. al. Moscow: Izdatel'skiy Dom MISiS, 2009. 496 p.
10. Defining rolled metal performance for cold bolt upsetting (bolt head) / Pachurin G. V., Shevchenko S. M., Filippov A. A., Mukhina M. V., Kuzmin N. A. // *IOP Conference Series: Materials Science and Engineering*. 2018. Vol. 327. P. 032040. doi: <https://doi.org/10.1088/1757-899x/327/3/032040>
11. Romanovskaya E. V. *Sozdanie novogo produkta na osnove sobstvennykh NIOKR* // *Vestnik of Minin University*. 2014. Issue 1.
12. Furuya Y. *Visualization of internal small fatigue crack growth* // *Materials Letters*. 2013. Vol. 112. P. 139–141. doi: <https://doi.org/10.1016/j.matlet.2013.09.015>
13. Furuya Y., Matsuoka S. *The Effect of Modified-ausforming on Giga-cycle Fatigue Properties in Si-Mn Steels* // *Tetsu-to-Hagane*. 2003. Vol. 89, Issue 10. P. 1082–1089. doi: https://doi.org/10.2355/tetsutohagane1955.89.10_1082
14. Estrin Y., Vinogradov A. *Extreme grain refinement by severe plastic deformation: A wealth of challenging science* // *Acta Materialia*. 2013. Vol. 61, Issue 3. P. 782–817. doi: <https://doi.org/10.1016/j.actamat.2012.10.038>
15. *Fatigue damage of ultrafine-grain copper in very-high cycle fatigue region* / Lukáš P., Kunz L., Navrátilová L., Bokůvka O. // *Materials Science and Engineering: A*. 2011. Vol. 528, Issue 22-23. P. 7036–7040. doi: <https://doi.org/10.1016/j.msea.2011.06.001>