

DESIGN OF WORKING BODIES FOR TILLAGE TOOLS USING THE METHODS OF BIONICS

H. Tesliuk

PhD, Associate Professor*

E-mail: super-shm@ukr.net

B. Volik

PhD, Associate Professor*

E-mail: volikb@ukr.net

S. Sokol

PhD, Associate Professor*

E-mail: sokol.sp.63@gmail.com

N. Ponomarenko

PhD, Associate Professor*

E-mail: nanagieva@ukr.net

*Department of Tractors and

Agricultural Machinery

Dnipro State Agrarian and

Economic University

Serhiya Yefremova str., 25,

Dnipro, Ukraine, 49600

В роботі наведена методика запозичення принципів будови тіла морських істот для розробки ґрунтообробних знарядь. Робота ґрунтообробних знарядь в умовах заниженої консолідації ґрунту вимагає саме покращення обтічності, тобто кришення та розпушення треба забезпечити не за рахунок підпірного різання, а за рахунок різання з ковзанням. За критерій раціональності конструкції прийнята величина тягового опору. Аналітична частина загальної методики дозволяє обчислити його величину. Новизна полягає в тому, що загальний тяговий опір розбитий на складові елементи, величина яких обчислюється окремо. Цей елемент є важливим, бо дозволяє при розрахунках перейти до прямолінійних нескінченно малих ділянок периметра і окремо виконувати адаптацію складових ріжучого периметра до оброблюваного середовища.

Наведені елементи подібності біологічного аналогу і технічного прототипу: лобова частина (рильце) → долотоподібний наконечник розпушувача; бокові плавники → стрільчасті крила; вертикальний кильовий плавник → комкоподрібновач. В результаті ідентифікації біологічного аналогу і технічного прототипу була отримана регресійна модель ріжучого периметра і робочої поверхні.

За результатами аналітичних досліджень запропонована математична модель взаємодії робочого органа з ґрунтом. Особливість аналітичної моделі взаємодії з ґрунтовим середовищем полягає в тому, що вона базується на умовах безпідпірного різання. Основні положення виконаних аналітичних досліджень підтверджені результатами модельних експериментальних досліджень, які показали зниження тягового опору у порівнянні з моделлю серійного робочого органа в середньому на 20 %. Такий результат можна отримати тільки за рахунок зменшення сил тертя, тобто покращенням обтічності робочої поверхні. Оригінальність отриманих наукових результатів полягає в повній адаптації робочих поверхонь біологічного аналогу до роботи в умовах ґрунтового середовища

Ключові слова: обробіток ґрунту, робоча поверхня, тяговий опір, обтічність форми, методи біоніки, ґрунтообробні знаряддя

1. Introduction

The design of tillage working bodies is defined by soil conditions under which they are planned to be used, as well as by the anticipated result of their interaction, and by the quality of crushing and loosening, as well as traction resistance. The working body under consideration is planned to be used under conditions of organic farming.

Organic agriculture is characterized by the presence in a surface layer of 0–15 cm of large amounts of plant residue, which have not yet fully undergone the stage of humification. Therefore, the surface layer demonstrates weak consolidation and its mechanical properties differ significantly from deeper horizons. Thus, there is a differentiation of soil layers by depth; this differentiation has clear boundaries. This point is important because a deep-ripper gives rise to cleavage lines that propagate along longitudinally-vertical and transversely-vertical planes. The character of the propagation of these cracks defines the crushing and loosening of a tilled environment.

Organic farming implies vertical tillage to a depth of 10 cm; at the same time, the root system of such crops as

corn, sunflower, sugar beet needs deep loosening. Annual use of screw shelf working organs is not appropriate because they plow plant debris for deep tillage thereby compromising the very essence of the farming system. Thus, chisel cultivation is mandatory.

2. Literature review and problem statement

Paper [3] reports results from analytical studies into the interaction between soil and the cutting perimeter of an arbitrary geometric shape. Underlying the research is the theory of internal stress. The theory makes it possible to estimate a value for the predicted traction resistance. However, the very notion of a cutting perimeter does not make it possible to describe the design in detail, which prevents its adaptation to operation in a specific soil environment. In study [4], the shortcoming was partially eliminated by the transition to the infinitely small, but the integrated shape of working surface must satisfy a series of requirements: it must be described by standard algebraic equations, that is, the stochastic models are not applicable. This significantly limits the possibilities

to adapt the working body to soil conditions. Paper [2] proposed a mathematical model that relates to the chisel-shaped working body; however, the working surface is imposed with an essential constraint: a model must be rectilinear. The model proposed in [5] does not account for branching in cleavage lines, which is why the derived estimated values for traction resistance and crushing are typically underestimated by 25–30 %. Study [6] describes the elements of a mathematical model for soil loosening based on the volumetric action of a force field created by a working body. However, the model cannot take into consideration changes in the curvature of the surface while passing the neutral position of a supporting wall. In paper [7], the estimated model was constructed based on building a continuous closed working perimeter of the tool, that is, by method of fitting. Article [8] reports a model of the directional wear of a working surface of the pointed paw. That provides opportunities to form a rational cutting surface, including the substantiation based on methods of bionics. The reported procedure can be extended to working surfaces of almost any shape. Thus, article [8] is the closest to the considered tasks.

Feature of the modern technologies of soil cultivation is an effort to minimize the mechanical effect on the tilted environment. Such an approach retains the biological activity of soil environment that increases the yield of farmed crops [9]. Especially sensitive to cultivation is corn [10]. A hallmark of the structure of its root system is that it requires that soil should be loose to depth of up to 25 cm. In this case, crushing should be within the range of obtaining the maximum possible amount of agronomically valuable units, with a reduced diameter of 0.25–10 mm. Working bodies with enhanced streamlining capacity enable the minimization of mechanical action while maintaining the required quality of crushing. Somewhat similar problems arise in the process of cultivating rice and wheat [11], but these crops require a smaller cultivation depth, which is 10–12 cm.

Among the recent significant innovations, one should note a system of organic farming. A special feature of this system is as follows. During conventional tillage by screw-shelf working bodies (ploughs), vegetable remnants of predecessor, or siderite, are plowed to a great depth of up to 25 cm. The system of organic farming implies that plant residue is immersed by vertical working bodies (turbo-disks) to a depth of 10–12 cm. The consequence is the presence in the soil environment of a large amount of plant remains, which have not undergone the stage of humification in full, that is the amount of sticky substances decreases. This leads to a corresponding reduction of soil consolidation, which is characterized by the specific particle adhesion [12]. The study conducted has confirmed a decrease in C_p under conditions of the black earth in Ukraine’s steppe zone from 2.5–3 kN/m² to 1.1–1.2 kN/m².

The essence relates to that the proper use of organic farming can reduce the need for fertilizers of inorganic origin and partially refuse the means of chemical protection. The result could mean obtaining environmentally-friendly produce.

The above analysis makes it possible to assert that it is necessary to change approaches to designing tillage tools. Therefore, an option for solving the specified tasks could be to design tillage working bodies applying the methods of bionics.

3. The aim and objectives of the study

The aim of this study is to adapt a tillage working body to an environment with the design parameters to be substantiated on the basis of an analysis into the structure of a biological analog’s body. That would make it possible to improve the technical and economic indicators for the technological process of soil cultivation.

The study objectives:

- to establish the elements of functional similarity;
- to construct the geometric, numeric, and regression model of the surface of a biological analog;
- to derive a mathematical model of the interaction between soil and the working surface of a tillage tool;
- to design an effective prototype and to test it practically.

4. Mathematical model of a working body’s surface

A comparative analysis of the design of deep-rippers and the structure of a body of marine animals has revealed that the biological analog that could be used is the body of a hammerhead fish [14].

Based on results of the visual analysis of a series of photographic images of the body of a biological analog, in accordance with the basic criteria of similarity, we have designed a structural scheme of the chisel (Fig. 1).

A mathematical model can be only regressive in character. Why so? The fact is that the equation should be modified in accordance with calculations based on the analytical model of interaction between a blade and soil. Modification is based on a numerical method, and a regression equation is derived exactly in this way. The input parameter is coordinate X_i , or the length of a body from the frontal part to the i -th cross-section, the output parameter is Y_i , or the working width of the i -th cross-section (Fig. 1).

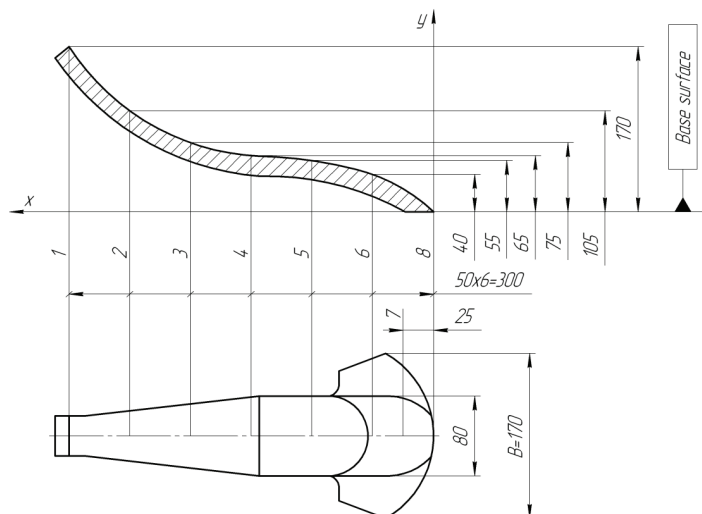

Fig. 1. Estimation scheme for designing a regression model of the surface of a working body

The dimensions of the body of a biological analog in Fig. 1 are scaled to the adopted working width of 170 mm based on the results from a dimensional analysis into the series of photographic images of an actual animal, they are therefore conditional.

The resulting numerical array (Table 1) is processed by the method of least squares to derive a regression equation of the surface profile.

Table 1

Numerical model of the surface profile of a biological analog

X, mm	Measured value	1.0	50	100	150	200	250	300
Y, mm	Measured value	1.0	40	55	65	75	105	170
	Estimated value	0.88	39.85	56.32	63.35	75.11	105.82	169.92
Criterion of similarity		0.006	0.24	0.32	0.35	0.44	0.62	1.0

The number of gradations of a cell grid is 8. Based on the results of calculations from [16], the cubic regression equation has high correlation coefficients, greater than 0.99, increasing the number of gradations to 12 leads to that the correlation coefficient increases by not more than 0.002. It should be noted that there is no need for a complete match between the profile of a prototype's blade and the analog. Bodies operate under different environments, and therefore one needs only an approximate dependence, which, further, at the next step, based on the analytical model of interaction with soil, would be adapted to work in the soil environment. Thus, the chosen cell size of the grid is enough.

A model would adequately reproduce an analog only if it is constructed in accordance with the criteria of similarity. In order to obtain a geometric model, it would suffice to use the trivial criteria that represent the ratio of two basic dimensions. For a given level of modeling, the trivial criterion of similarity is:

$$K_{BT} = \frac{B}{Y_i}, \tag{1}$$

where B is the structural working width of a working body; Y_i is the width of an analog at the i -th cross-section.

To derive an estimation scheme, one must use the integrated criteria of similarity, which is obtained using the method of analysis of dimensionalities of the analytical model of interaction between soil and a cutting perimeter of arbitrary geometrical shape [4],

$$\left(\frac{C_p \cdot P_g \cdot b}{\gamma_g \cdot V^2 \cdot P_{VR} \cdot a} \right)_H^n = \left(\frac{C_p \cdot P_g \cdot b}{\gamma_g \cdot V^2 \cdot P_{VR} \cdot a} \right)_M^m = K_p, \tag{2}$$

where C_p is the specific adhesion among soil particles; γ_g is the specific weight of soil; V is the operating speed of a tillage tool; P_g is the horizontal component of the traction resistance of a working body; P_{VR} is the vertical component of traction resistance; B is the reduced working width of a working body [4]; a is the depth of stroke by a tillage tool.

The calculation result is the derived cubic regression equation (3).

$$Y = -0.00001892X^3 - 0.007564X^2 + 1.1328X - 0.2377. \tag{3}$$

Correlation coefficient $K_C=0.9995$; determination coefficient $K_d=0.999$; systematic error $E=4.9\%$.

For the estimated scheme, we accept the basic structural element to be a working width $B=170$ mm; according to the second theorem of similarity, equation (3) is represented in the form of a criterial equation – it will act as a working equation hereafter.

$$K_{\Pi} = (0.11X^3 - 43.74X^2 + 0.6446X + 3515) \cdot 10^{-6}. \tag{4}$$

The essence is the fact that, when proceeding to design an actual tool, it would suffice to adopt the size of a base element, that is, its working width, and, according to the criterial equation, to build the entire working surface.

5. Mathematical model of interaction between soil and the designed working body

There is a model [4], which makes it possible to calculate the predicted traction resistance of a tool, although it relates to a group of tools of a specific geometric shape, which is why it does not seem possible to extend the procedure for an arbitrary geometric shape.

Underlying the procedure proposed here is the theory of internal stress [3], which in turn is continuation of research [1].

The essence of the model is as follows. The process of interaction that involves a working body of an arbitrary geometrical shape is divided into two stages:

- the cutting perimeter of a tool separates a prism of soil from the entire array;
- the subsequent crushing of a chipped prism occurs by overcoming the internal stress with working surfaces of the tool; internal stress has previously existed in the consolidated soil.

Thus, we introduce two concepts:

- the cutting perimeter as a projection of all cutting edges of the tool onto the plane perpendicular to motion direction [1];
- the internal stress, which is defined as the vector sum of all adhesion forces operating in an environment, from the molecular to aggregate level [4].

A working body is regarded to be a geometrical sum of surfaces, oriented in space in a certain manner.

Traction resistance of the cutting perimeter is conditionally divided into the following components: P_{CK} is the strength of chipping a prism of soil by a frontal part; P_T is the force of soil pressure on working surfaces; P_{TR} are the forces of soil friction against working surfaces; P_D is the dynamic component of resistance force.

Next, we determine analytically those forces that were applied to the working body.

5.1. The strength of chipping a prism of soil by a frontal part

A prism of soil is chipped by the cutting edge of the chisel. Other elements of the working surface, including the wings, do not participate in chipping because cleavage lines overlap their working width.

A procedure for determining the chipping force was thoroughly analyzed in papers [3, 6, 15].

The procedure implies that the profile of the blade of a working body is divided into infinitesimal sections that give rise to the propagation of cleavage lines that form a prism.

The strength of chipping a prism is determined from formula:

$$P_{CK} = C_p F_{CK}, \tag{5}$$

where F_{CK} is the total chipped area.

Thus, determining the strength implies defining the area of the chipped prism [4].

5. 2. Force of pressure and friction of soil against working surfaces

For the designed tool, one must separately consider the surface of the chisel and the surface of the wings. For both components, in line with recommendations from [3], one can applied the equation of a supporting wall [6].

For the positive angle β of the wall tilt, the pressure along the normal to the surface E_a is determined from formula [13]:

$$E_a = \frac{\gamma \cdot H^2}{2} \cdot \left[\operatorname{tg} \left(45 - \frac{\varphi + \beta}{2} \right) + \operatorname{tg} \beta \right]^2 \cdot \cos \beta, \tag{6}$$

where γ is the specific weight of soil; H is the depth of the wall immersion; β is the wall inclination angle to the vertical; φ is the angle of internal friction.

Consider the estimation scheme (Fig. 2) relative to the designed tillage tool. Coordinate origin is at a chisel's tip.

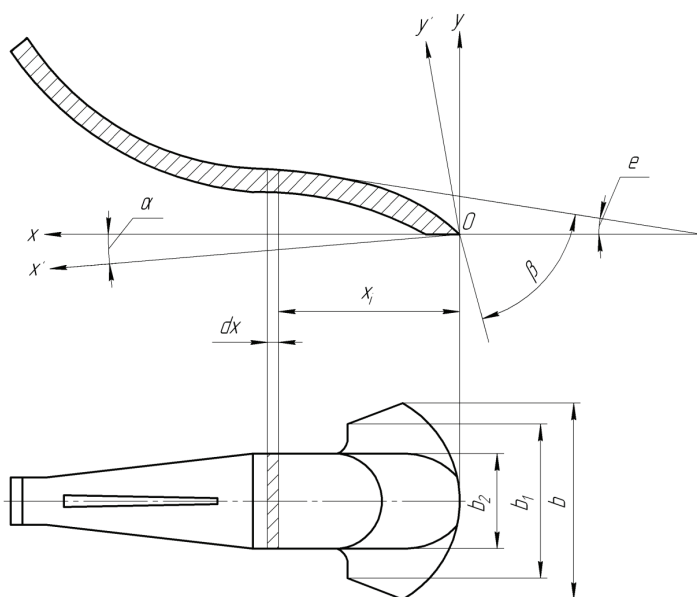

Fig. 2. Estimation scheme for determining soil pressure on the tool's working surfaces: α is the angle of attack

The surface regression equation (3) was derived in the XOY coordinates. We represent the surface of the chisel as a sum of infinitesimal sections dx . Such sections can be considered flat with the angles of setting them up vertically and the motion direction.

In the XOY coordinates, the tangent of angle ε of the section's tilt to the bottom of the furrow would equal the first derivative at point X_i :

$$\varepsilon = \operatorname{arctg}(dY/dX). \tag{7}$$

However, the working body is installed at angle of attack α to the bottom of the furrow. Let us turn coordinate

axes at angle α – the angle of attack of the working body in general, and obtain a new coordinate system $X'OY'$ in which the X' axis coincides with the motion direction of the chisel.

Then the angle of setting an elementary section to the vertical in a moving coordinate system is:

$$\beta = 0.5\pi - \varepsilon - \alpha. \tag{8}$$

Determine the force acting on a randomly selected section, located at a distance X_i from the tip:

$$dP_T = \frac{\gamma \cdot Y_i^2 \cdot b_2}{2} \cdot \left[\operatorname{tg} \left(45 - \frac{\varphi + \beta}{2} \right) + \operatorname{tg} \beta \right]^2 \cdot \cos \beta \cdot dx. \tag{9}$$

The general surface response is:

$$P_T = \int_{x=0}^{x=L} \frac{\gamma \cdot Y_i^2 \cdot b_2}{2} \cdot \left[\operatorname{tg} \left(45 - \frac{\varphi + \beta}{2} \right) + \operatorname{tg} \beta \right]^2 \cdot \cos \beta \cdot dx, \tag{10}$$

$$P_{TP} = P_T \operatorname{tg} \varphi, \tag{11}$$

where L is the total length of the working section; φ is the angle of the external soil friction against steel.

The instantaneous direction of action of force P_T is the normal to the surface profile; force P_{TR} – tangentially to the profile. Knowledge of the predicted value for forces P_{CK} , P_T , P_{TR} according to the theory of internal stress [3] is a necessary and sufficient condition for the project calculation of the degree of soil crushing by a tool.

6. Results of studying the model of an experimental sample of a tillage tool

The experimental study was performed under conditions of a soil channel the size of $50 \times 500 \times 7,000$ m, filled with a model environment (Fig. 3). The model environment was a mixture of sand of different fractional composition. The mechanical-technological properties were evaluated based on the specific adhesion of particles, which was taken as an integrated index [12].

A design feature of the channel is that the riser of the examined working body is fixed on a cart with two springs, which makes it possible to measure both longitudinal and transverse components of the forces of traction resistance. The components of traction resistance were measured using a tensor chain in line with common procedures.

For this experiment, we printed, at a 3D printer, the experimental and standard deep-rippers with a scale ratio M1:2. The experimental study has confirmed the proper choice of a biological analog, as well as the research concept in general. The accepted criterion of rationality was the measured value for traction resistance of the experimental and standard deep-rippers. The models were made from plastic material, that is the coefficients of external friction did not match actual conditions, but the simulation of interaction was conducted in full compliance with the criteria of similarity [1]; in other words, they are easily reproduced. The research results are given in Table 2. The procedures for determining soil properties are given in [12].



Fig. 3. A stage of research in a soil channel

Table 2

Results of research into the traction resistance of models

Variant of the model of a deep-ripper	C, kN/m ²	V, m/s	P, H (measured value)	P, H (estimated value)
Experimental sample	1.05	0.35	120	138
	1.3	0.36	136	144
Standard	1.05	0.35	155	163
	1.3	0.36	170	181

Notes: C – specific adhesion of soil particles; V – operating velocity; P – traction resistance

An analysis of data from the Table reveals that the designed model of a deep-ripper ensures a decrease in the absolute value for traction resistance in the range of 20 %, and improves the structure of tilled soil by 7%. According to the theory of similarity, it can be argued that the specified trend would also be valid for the field sample of a working body.

7. Discussion of results of studying the interaction between soil and the experimental sample of a deep-ripper

A decrease in the traction resistance of the model of an experimental sample of a working body in comparison with a standard model is explained by that soil streamlines the working surfaces better. The result is the reduced forces of pressure and friction. The positive effect is that it reduces the total traction resistance of a unit and, consequently, fuel consumption. In addition, we predict improvement in performance due to the possibility to increase working velocity. However, this issue requires additional research into the feasibility of velocity acceleration in terms of compliance with farming operations.

An analysis of data from Table 2 shows that the estimated values outperform, by 5–7 % on average, those that were obtained experimentally. This can be explained

by certain assumptions, adopted in the model, such as the introduction of an integrated index for mechanical-technological properties [4]. The quality of crushing was estimated based on the coefficient of structure arrangement, which was defined as a ratio of the mass of agronomically valuable units to the total mass of an individual sample. For a standard paw, this indicator is 0.57–0.62, for the designed one – 0.65–0.75.

The limitations of the study that should be noted relate to that the resulting shape of the surface of a working body is complex and would change under the influence of abrasive wear, which could decrease the efficiency of the design. However, under conditions of industrial production the issue of a shape is easily solved. Abrasive wear can be minimized by cementing the surface or by applying a wear-resistant coating. It should be noted that the current work has solved the task on the basic, that is deep, tillage, which is performed in autumn. As regards the surface, that is spring, tillage, then, subject to maintaining the basic principles, as well as the substantiation of an appropriate biological analog, the current procedure could be extended to the tools of surface cultivation.

Regarding the further advancement of our research, there are the following considerations. First, it is promising to generalize the procedure for the entire group of marine animals. Second, it is necessary to extend the procedure for earth-moving animals. Third, it is necessary to summarize the methodology of experimental research, aimed at adapting the tools to soil conditions.

8. Conclusions

1. By means of a visual analysis of body structure of the most common species of marine animals it was found that the body structure of hammerhead fish corresponds best, in terms of functionally, to the structure of a deep-ripper of the chisel type; and, therefore, hammerhead fish can be accepted as a biological analog. The elements of identification are: analog’s body → riser; vertical fin → crumbler; side fins – blades-razors.

2. The geometric model of a working body corresponds to the area of the wetted surface of the analog. The regression model of the cutting perimeter: $Y=0.00001892X^3-0.007564X^2+1.1328X-0.2377$, where Y is the transverse, X is the longitudinal coordinates.

3. We have designed an analytical model of interaction between a soil environment and a working body with elevated streamlining capacity. The main differences of the model are in the representation of the cutting perimeter of a working body as the totality of infinitely small rectilinear sections, in determining the response of soil to the effect of these sections, and their subsequent integration along the actual profile of the cutting perimeter.

4. Based on the model, we have designed an actual structure of a deep-ripper. The main difference from the prototype is that we rejected the straightness of working sections and passed to the profiles that were obtained based on a regression analysis of the body of a marine animal. The performed model study in a soil channel confirms that our design makes it possible to lower, by up to 20 %, the overall traction resistance when working under soil conditions of the model environment in comparison with the prototype.

References

1. Vetrov Yu. A. Rezanie gruntov zemleroynymi mashinami: monografiya. Moscow: Mashinostroenie, 1971. 357 p.
2. Vetokhin V., Getman O., Bilytska N. To the issue of creating the form of working surface taking into account the exchange of the volume between the working body and a soil // Pratsi Tavriyskoho derzhavnoho ahrotekhnolohichnoho universytetu. 2011. Vol. 51, Issue 4. P. 87–94.
3. Modeliuvannia yakosti rozpushennia hruntu dolotom / Kobets O., Tesliuk H., Volyk B., Lepet Ye. // Tekhnika i tekhnolohiyi APK. 2015. Issue 6. P. 31–33.
4. Panchenko A. N. Teoriya izmel'cheniya pochv pochvoobrabatyvayuschimi orudiyami. Dnepropetrovsk: DGAU, 1999. 140 p.
5. Kobets A. S., Volyk B. A., Puhach A. M. Gruntoobrobni mashyny: teoriya, konstruktsiya, rozrakhunok: monografiya. Dnipropetrovsk: Svidler A. L., 2011. 140 p.
6. Semeniuta A. M., Bilokopytov O. V., Volyk B. A. Metodyka rozrakhunku zahalnoi reaktsiyi rizannia gruntu poverkhneiu dovilnoi heometrychnoi formy // Pratsi Tavriyskoho derzhavnoho ahrotekhnolohichnoho universytetu. 2010. Vol. 2, Issue 10. P. 161–167.
7. Chuyko I. S., Volik B. A., Kolbasin V. A. Obosnovanie konstruktivnih parametrov V-obraznogo orudiya dlya chizelevaniya pochvy // Problemy ta perspektyvy rozvytku ahrarynoi mekhaniky. Materialy Mizhnarodnoi naukovo-praktychnoi konferentsiyi. Dnipropetrovsk: DDAU, 2004. P. 29–33.
8. Kobets A. S., Pugach A. M., Kharytonov M. M. Justification of the cultivator sweep and strengthening elements on the working surface // INMATEG Agricultural Engineering. 2018. Vol. 54, Issue 1. P. 161–170.
9. Conservation tillage impacts on soil, crop and the environment / Busari M. A., Kukul S. S., Kaur A., Bhatt R., Dulazi A. A. // International Soil and Water Conservation Research. 2015. Vol. 3, Issue 2. P. 119–129. doi: <https://doi.org/10.1016/j.iswcr.2015.05.002>
10. Rotary zone tillage improves corn establishment in a kura clover living mulch / Dobbratz M., Baker J. M., Grossman J., Wells M. S., Ginakes P. // Soil and Tillage Research. 2019. Vol. 189. P. 229–235. doi: <https://doi.org/10.1016/j.still.2019.02.007>
11. Sustainability issues on rice–wheat cropping system / Bhatt R., Kukul S. S., Busari M. A., Arora S., Yadav M. // International Soil and Water Conservation Research. 2016. Vol. 4, Issue 1. P. 64–74. doi: <https://doi.org/10.1016/j.iswcr.2015.12.001>
12. Mekhaniko-tekhnolohichni vlastyvoli silskohospodarskykh materialiv: navch. pos. / Kobets A. S., Ishchenko T. D., Volyk B. A., Demydov O. A. Dnipropetrovsk: RVV DDAU, 2009. 84 p.
13. Tsytoich N. A. Mekhanika gruntov (kratkiy kurs): ucheb. 4-e izd., pererab. i dop. Moscow: Vysshaya shkola, 1983. 288 p.
14. An analysis of the structure of the body of marine animals for the possibility of accepting it as a biological analogue / Volyk B., Tesliuk H., Zolotovska O., Maistryshyn R. // Tekhnika i tekhnolohiyi v APK: naukovo-vyrobnychyi zhurnal. 2018. Issue 5 (104). P. 7–9.
15. Tesluk G. V., Volik B. A., Maistryshyn R. M. Improvement of technological processes and technical means soil treatment in organic farming system // Inzheneriya pryrodokorystuvannia. 2016. Issue 1. P. 48–52.
16. Aproksimatsiya funktsii odnoy peremennoy. URL: <https://planetcalc.ru/5992/>