

DEVELOPMENT OF NEURAL-NETWORK AND FUZZY MODELS OF MULTIMASS ELECTRO-MECHANICAL SYSTEMS

G. Kaniuk

Doctor of Technical Sciences, Professor*

E-mail: art-studio_diana_@ukr.net

T. Vasylets

PhD, Associate Professor*

E-mail: tatyana.vasilets@gmail.com

O. Varfolomiyev

PhD

DeVry University

Madison ave., 180, New York, USA, 10016

E-mail: ov5@njit.edu

A. Mezeria

PhD, Associate Professor*

E-mail: mezz@mezz@mail.ru

N. Antonenko

PhD, Associate Professor*

E-mail: nsantonenko2015@gmail.com

*Department of Heat Power Engineering and

Energy Saving Technologies

Ukrainian Engineering Pedagogics Academy

Universytetska str., 16,

Kharkiv, Ukraine, 61003

Метою роботи є побудова моделей багатомасових електромеханічних систем з застосуванням нейронних мереж, систем нечіткого висновку і гібридних мереж інструментальними засобами MATLAB. Модель системи у вигляді нейронної мережі або системи нейро-нечіткого висновку будується на основі відомих вхідних сигналів і вимірних сигналів на виході системи. При проведенні досліджень використані методи теорії штучних нейронних мереж і методи технології нечіткого моделювання.

Виконано синтез нейронної мережі для вирішення завдання ідентифікації електромеханічної системи із складними кінематичними зв'язками з застосуванням пакету прикладних програм Neural-network Toolbox системи MATLAB. Розглянуто можливість вирішення задачі ідентифікації за допомогою нечіткої апроксимуючої системи з використанням пакету Fuzzy Logic Toolbox. Проведено синтез гібридні мережі, реалізованої у формі адаптивної систем нейро-нечіткого висновку з застосуванням редактора ANFIS. Надано рекомендації з вибору параметрів, що найбільш суттєво впливають на точності ідентифікації при застосуванні розглянутих методів. Показано, що використання нейронних мереж і адаптивних систем нейро-нечіткого висновку дозволяє виконувати ідентифікацію систем з точністю 2–4 %.

В результаті проведених досліджень показана ефективність застосування нейронних мереж, систем нечіткого висновку і гібридних мереж для ідентифікації систем із складними кінематичними зв'язками при наявності інформації "вхід-вихід". Виконано синтез нейромережевої, нечіткої і нейро-нечіткої моделей двомасової електромеханічної системи з використанням сучасних програмних засобів.

Розглянутий підхід використання технологій штучного інтелекту – нейронних мереж і нечіткої логіки – є перспективним напрямом для побудови відповідних нейромережевих і нейро-нечітких моделей технологічних об'єктів і систем. Результати досліджень можуть бути використані при синтезі регуляторів систем із складними кінематичними зв'язками для забезпечення високих показників якості функціонування систем

Ключові слова: ідентифікація багатомасових систем, нейромережеві моделі, нечіткі апроксимуючі системи, гібридні мережі

1. Introduction

When modern control systems are synthesized, the problem of identification persists to be extremely important. It is impossible to provide high quality control without use of a mathematical model reflecting properties of the control objects with a high degree of accuracy. Analysis of dynamic processes in multimass electromechanical systems presents a considerable complexity which is further aggravated in practice by the lack of precise quantitative characteristics of all elements and connections. Transition processes in such systems may have poor qualitative indicators. For efficient control of multimass electromechanical systems, it is necessary to have their mathematical models that reflect the system properties with a high degree of accuracy. However, the desire to get exhaustive information for constructing an

exact mathematical model of a complex system can result in a loss of time and resources since this can be technically impossible. The lack of complete information on operating conditions, properties and parameters of objects and systems necessitates the use of an adaptive approach to control which tolerates the use of simplified, in particular, linear models. Although this approach makes it possible, in some cases, to significantly reduce a priori uncertainty and implement rather effective control, constriction with linear models does not always ensure obtaining of desired results.

Application of neural-network technologies is one of the promising lines of constructing mathematical models of complex objects and systems based on measured input and output signals. When applied to the systems of control of neural-network regulators, system models are used in a form of neural nets for implementation of control algo-

rithms. The use of neural nets as models can serve as an alternative to classical identification methods since precise knowledge of internal processes is not a prerequisite for modeling in this case.

In addition to neural nets, methods based on the theory of fuzzy sets and fuzzy logic, namely the technologies of fuzzy modeling have found wide application in solving problems of identification. These methods are effective when information about the subject under study is incomplete or inaccurate.

Currently, structures are developed that combine the best properties of neural-network and fuzzy methods: hybrid networks in which the fuzzy inference system is presented as a neural net which can be taught by the methods applicable to neural nets. This makes it possible to use computing power of neural nets in fuzzy logic systems and enhance intellectual capabilities of neural nets using fuzzy rules of decision making.

Therefore, current studies on application of the neural-network technologies and the fuzzy modeling technology to improve accuracy of identification of electromechanical systems with complex kinematic connections are urgent in the absence of complete information about their structure and parameters.

2. Literature review and problem statement

As is known, the mechanical part of electromechanical systems is a system of interconnected masses moving at different speeds, that is, a multimass system. Presence of elastic connections and nonlinear elements in electromechanical systems complicates application of classical methods of system analysis and synthesis. A procedure of non-conventional choice of parameters of speed regulators of subordinate regulation systems is proposed in [1]. The studies [2, 3] address the synthesis of followers and regulators that are robust and optimal by various criteria and make it possible to satisfy various requirements to operation of multimass electromechanical systems in various modes. Synthesis of such regulators is based on a mathematical model of electromechanical system. However, when regulators are synthesized, simplified models of multimass systems are used which reduces accuracy of regulation. In the case of identification, real electromechanical systems are replaced by equivalent systems with concentrated masses. A mathematical model of an equivalent system is formed and its parameters are determined. These models do not take into consideration all factors that influence the dynamic processes in multimass systems. Studies [4–14] tackle the issues of improving accuracy of identification of parameters of multimass system models. A method for identifying parameters of the mechanical component of the electromechanical system with many masses and elastic connections and viscous friction between them is given in [4]. However, it is necessary to take experimental tachographs of all masses to implement this method which is very difficult to realize in real systems. A method of identification of parameters of a two-mass electromechanical system on the basis of genetic algorithms is presented in [5]. However, it was established by studies that the method based on genetic algorithms makes it possible to identify parameters with accuracy sufficient for practical purposes but only for a simplified linear mathematical model. An analysis of methods for identification of dynamic

systems in relation to electric drives of port transshipment machines which are complex electromechanical systems with mechanical equipment containing elements with elastic connections is presented in [6]. Peculiarities of these systems which require taking into consideration gaps in gear gears, elasticity in shafts, change of moments of inertia in gear rims and stiffness of elastic elements in couplings when solving problems of modeling and identification. However, algorithms of determining parameters of frequency characteristics of only individual elements of the systems are considered in the paper, namely: a PI regulator, a DC motor, and a thyristor converter. An algorithm of parametric identification of electromechanical systems whose mathematical models are described by a system of Cauchy relations is proposed in [7]. As an example, the problem of parametric identification of an asynchronous squirrel-cage induction motor by the transient curve of the direct start process at a specified load is considered. Application of this method to identification of multimass electromechanical systems will lead to significant errors because, as it was noted, the state equations can be written only for an equivalent model with concentrated loads which does not take into consideration all the factors influencing dynamic processes in multimass systems. Methods of identification of parameters of a multimass electromechanical system using the nonlinear least squares method are presented in [8]. However, the presented methods have been applied in parametric identification of a linear system with delays. Paper [9] reports a study into the expediency and usefulness of employing continuous wavelet transformation for estimation of model parameters, such as attenuation factors and eigenfrequencies of two-mass and three-mass electromechanical systems. Identification using a continuous wavelet transform is compared with the Gilbert-Huang transform technique and is evaluated in terms of accuracy and ability to evaluate system parameters. These methods are quite effective but they enable evaluation of just individual parameters of the multimass systems. Methods for determining frequency characteristics of two- and three-mass systems using the Welch method were proposed in [10–12]. However, the frequency characteristics widely used as models of linear dynamic objects do not reflect dynamic processes in actual multimass electromechanical systems. In works [13–16], when approximating properties of two-mass [13–15] and three-mass [16] electromechanical systems, it is proposed to use linear statistical models that have proved to be well-established in practice, namely: an autoregressive model with additional input signals (ARX model) and an output error model (OE model). Such models are simple and can be used to verify their adequacy and the well-developed methods for analyzing frequency characteristics are the main advantage in their application. Methods for identifying parameters of these models are presented in studies. However, application of linear models to complex nonlinear systems, such as multimass electromechanical systems does not provide necessary accuracy for control purposes.

The use of artificial intelligence technologies – neural nets and fuzzy logic – opens up wide opportunities for control of complex systems. Knowledge of exact structure and system parameters is not a prerequisite for realization of control algorithms. A model of a system in a form of a neural net or a system of neuro-fuzzy inference is constructed on the basis of known input signals and the signals measured at the system output. Some papers devoted to identification of complex technological processes and systems using

neural nets [17–26], systems of fuzzy inference [27–35] and neuro-fuzzy systems [36–41] are given in the reference list. However, the problems of synthesis of neural-network and fuzzy models of electromechanical systems with complex kinematic connections were not considered.

Analysis of published data suggests that it is expedient to conduct a study on identification of multimass electromechanical systems using neural nets, fuzzy inference systems and hybrid networks.

3. The aim and objectives of the study

The study objective is to construct models of multimass electromechanical systems using neural nets, fuzzy inference systems and hybrid networks based on measured input and output signals with the help of MATLAB tools. This will enable improvement of accuracy of identification of electromechanical systems with complex kinematic connections in absence of complete information about their structure and parameters and provide high quality of control.

To achieve this objective, the following tasks were solved:

- to synthesize a neural-network model of a two-mass electromechanical system using the GUI interface of the Neural Network Toolbox;
- to develop a fuzzy model of a two-mass electromechanical system presented in a form of fuzzy inference systems with the use of Fuzzy Logic Toolbox;
- to construct a model of a two-mass electromechanical system using hybrid networks realized in a form of adaptive systems of the ANFIS neuro-fuzzy inference.

4. Synthesizing and studying the neural-network model of a two-mass electromechanical system

The MATLAB system includes the Neural Network Toolbox package that is a tool helping users develop design methods and extends the scope of application of neural nets [42]. This package includes an NNTool graphical interface which is very convenient to use and simplifies work with neural nets.

Synthesis of neural-network models of complex systems using NNTool is considered on an example of creation of a neural net for identification of a two-mass electromechanical system whose transient processes have the character of weakly damped oscillations. Next, accuracy of the obtained neural-network model will be evaluated by comparing the model values with the values obtained by modeling a two-mass electromechanical system in the Simulink environment of the MATLAB system.

The DC motor is powered from a thyristor rectifier. The shaft of the motor and rigidly connected elements of the system with the moment of inertia J_d is connected with the working mechanism having moment of inertia J_m by an elastic connection having stiffness coefficient c and viscous friction coefficient β . The control system has an internal current loop and an external electromotive force (EMF) loop. The current loop is tuned to a modular optimum and (taking into consideration compensation of the time constant of the motor rotor loop using the PI regulator) has an integrator and one small non-compensated time constant $T_{\mu T}$. The EMF loop is tuned according to the symmetric criterion.

The system of differential equations of a two-mass electromechanical system has the form:

$$\left\{ \begin{aligned} \frac{d\omega_m(t)}{dt} &= \frac{1}{J_m} M_{pr}(t) + \frac{\beta}{J_m} \omega_d(t) - \frac{1}{J_m} \omega_m(t) - \frac{1}{J_m} M(t); \\ \frac{dM_{pr}(t)}{dt} &= c\omega_d(t) - c\omega_m(t); \\ \frac{d\omega_d(t)}{dt} &= \frac{1}{J_d} M_d(t) - \frac{1}{J_d} M_{pr}(t) - \frac{\beta}{J_d} \omega_d(t) - \frac{\beta}{J_d} \omega_m(t); \\ \frac{dM_d(t)}{dt} &= \frac{1}{k_d} P(t); \\ \frac{dP(t)}{dt} &= \frac{k_{pe}}{2T_{\mu}^2 k_t} E_{zE}(t) - \frac{k_{pe}}{2T_{\mu}^2 k_t} U_{zE}(t) - \\ &\quad - \frac{k_d}{2T_{\mu T}^2} M_d(t) - \frac{1}{T_{\mu T}} P(t) + \frac{1}{2T_{\mu}^2 k_t} U_{iE}(t); \\ \frac{dE_{zE}(t)}{dt} &= \frac{1}{T_a} U_{zE}(t) - \frac{1}{T_a} E_{zE}(t); \\ \frac{dU_{zE}(t)}{dt} &= \frac{k_n}{T_a k_d} \omega_d(t) - \frac{1}{T_a} U_{zE}(t); \\ \frac{dU_{iE}(t)}{dt} &= k_{ie} E_{zE}(t) - k_{ie} U_{zE}(t), \end{aligned} \right.$$

where $\omega_d(t)$, $\omega_m(t)$ are angular speeds of the motor and the mechanism; $M_d(t)$ is the motor torque; $M_c(t)$ is the moment of static load; $M_{pr}(t)$ is the moment of elasticity;

$$P(t) = M_d(t)/dt$$

is the jerk; $U_{zE}(t)$, $E_{zE}(t)$ is voltage and EMF of the task; $U_{zE}(t)$ is voltage of feedback by EMF; $U_{iE}(t)$ is the output voltage of the integrator of the PI regulator of EDF; T_a is electromechanical time constant of the electric motor; k_d is coefficient of motor gain; k_t is coefficient of feedback current gain; k_n is coefficient of feedback voltage gain; k_{pe} , k_{ie} are coefficients of gain of the proportional and integral parts of the PI regulator of the EMF loop.

Before proceeding with development of a neural-network model of a two-mass system, it is necessary to form arrays containing the network training data. To check quality of training, it is expedient to form arrays of control and test sequences. To this end, the model of a two-mass system developed in Simulink can be used (Fig. 1). The arrays formed with this model are then loaded into the NNTool workspace.

To construct a neural-network model of a dynamic object, it is necessary to set the input sequence based on the current value of the input signal of the object and a number of previous values of the input and output signals. The orders of the input n_{in} and output n_{out} signal delays are pre-selected based on a priori knowledge about the object of identification (if any) and the researcher's experience and then refined experimentally in the process of neuromodel's construction. It was established by multiple modeling that the best result for a two-mass electromechanical system is obtained if n_{in} and n_{out} are within the limits of 1–2 and 2–5, respectively.

Let us form the input sequence based on the current value of the input signal of the system, $U_{zE}(k)$, and the input signal delayed by one step of discreteness, $U_{zE}(k-1)$. Also, use the output signal delayed by one step, $\omega_m(k-1)$ and two steps, $\omega_m(k-2)$. Corresponding values of the mechanism speed, $\omega_m(k)$, are the initial sequence.

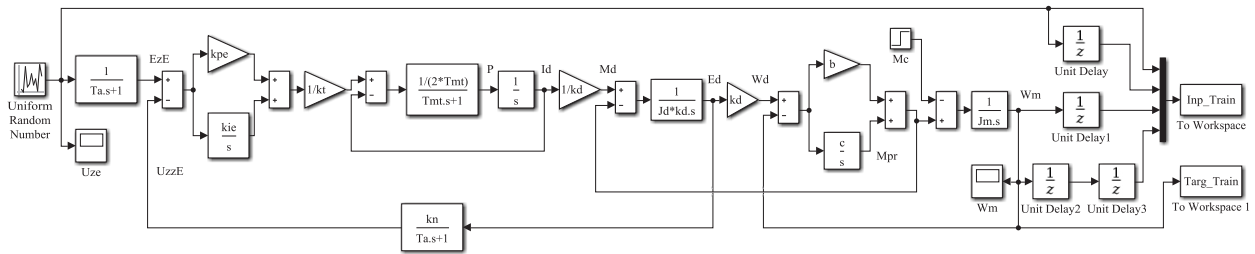

Fig. 1. The Simulink model of a two-mass electromechanical system

To form delayed signals, use Unit Delay units. It is necessary to specify the discreteness cycle in the parameter specification window of the unit. When specifying the value of the discreteness cycle, the following must be considered. Quality of the neural net training depends on the size of the training sample, N_B , and the interval between two consecutive moments of data reading, that is, the discreteness cycle, Δt . With an increase in Δt , the training quality decreases and the difference between the training errors and the errors occurred in the control and test sets increases. When there is a significant decrease in Δt , N_B must be increased accordingly which results in a significant increase in the network training time and a significant reduction of the network training error is not observed. The value of Δt is initially selected roughly for each object of identification proceeding from the available information about the object's dynamic properties and then refined during modeling. For this example, it was established that the training sample N_B must contain at least 8,000–10,000 values and the discreteness cycle, Δt , should be 0.03–0.05 s.

To Workspace and To Workspace1 units are used in the model diagram shown in Fig. 1 to write sequence of values of inputs and targets into the MATLAB system workspace. In this case, these are $U_{zE}(k)$, $U_{zE}(k-1)$, $\omega_m(k-1)$, $\omega_m(k-2)$ signals and the mechanism speed, $\omega_m(k)$, respectively. The discreteness cycle (the same value as for the Unit Delay unit, $\Delta t=0.05$ s) and format of the stored data should be specified in the unit's task window. Data should be saved as an array in which the number of lines is determined by the size of the training sample, N_B , and the number of columns by the number of signals sent to the unit input. In this example, the array of inputs contains 4 columns, and the array of targets contains one column.

The Uniform Random Number unit is used as a signal source in the diagram of Fig. 1. Minimum and maximum signal levels and the identification interval should be specified in the task window of this unit.

The minimum and maximum value of the input signal (the task voltage), $U_{zE}(t)$, is chosen during synthesis of the system of subordinate regulation (+10 V and -10 V, respectively, in the example under consideration).

To get a representative sample, it is necessary to specify correct value of the identification interval t_i , that is, length of the interval during which the task signal remains unchanged. Its value depends on dynamic characteristics of the system. As the study results have shown, to achieve high identification accuracy, only acceleration phases should be contained in the training data. The value of this parameter, and practically of the remaining parameters, is selected roughly and then refined in the modeling process. In this example, the t_i values should be selected from a range of 3–5 s. Take $t=5$ seconds.

If modeling time of 500 s is specified in the window of the Simulink system model and the system modeled, the input and output arrays will contain 10,001 lines. Graphs of the input, $U_{zE}(t)$, and output, $\omega_m(t)$, signals of the system are shown in Fig. 2. When the size of arrays is reduced, that is, value of the training sample, N_B , results of the network training may be unsatisfactory. Similarly, control and test sequences are formed. For their further use, the formed arrays should be saved in the binary MAT files with the Save command.

In order to use the obtained arrays in training of the neural net, they must first be transposed. For this purpose, debugger of the MATLAB m-files can be used. The transposed arrays of inputs contain four lines and the arrays of targets contain one line. The number of array columns corresponds to sizes of the corresponding sequences. Sequences of inputs and targets are loaded into the NNTool workspace.

Following the training data formation in the main window of the NNTool Network/Data Manager interface, create a two-layer neural net with a direct signal transmission.

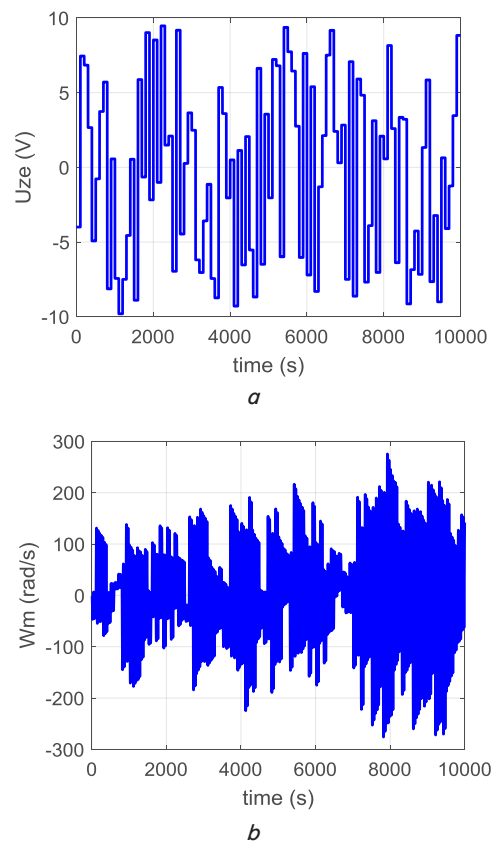

Fig. 2. Graphs of signals at the system input and output: the graph of the input signal, $U_{zE}(t)$ (a); the graph of the output signal, $\omega_m(t)$ (b)

The number of neurons in the first (hidden) layer is one of the main factors influencing the identification result. If the number of neurons is insufficient, then the training results are unsatisfactory. A problem of re-training occurs at a large number of neurons. As the studies have shown, an optimal number of the hidden layer neurons for this task of identification is within the range of 8–12 and the training error as well as errors in the control and test sets do not exceed 2×10^{-2} . The number of neurons is 1 in the second layer.

The functions of neuron activation should be as follows: hyperbolic tangent function in the first layer and linear function in the second layer. The most effective training function is TRAINLM which corresponds to Levenberg-Marquardt algorithm.

The network initialization and training are then performed. The NNTool interface dialog panels provide ranges of initial values and initialization of network weights, input and output sequence names, training process parameters and network training. Dynamics of change of the training error as well as the check in the control and test sets are reflected in the window shown in Fig. 3

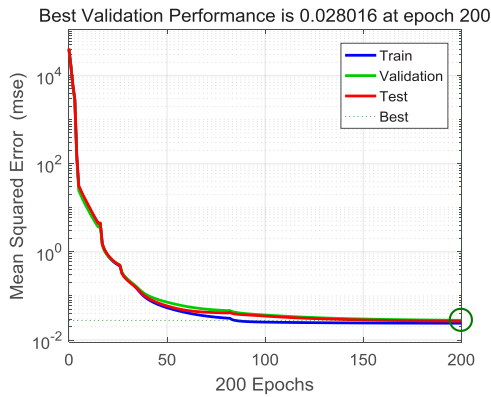

Fig. 3. Window of the training process control

The network training result depends on the initial value of weights of the neural-network, w_{ij} , and the number of

training cycles N_c (epochs). To achieve the global minimum, the training process needs to be repeated many times at different initial values of w_{ij} and N_c . In this task, several dozen starting points of calculation were selected for each network option (that is, the number of neurons in the first layer) and the number of delayed signals. The number of training cycles after which the training error ceased to decrease was 200–300 with an error of training approximately equal to 2×10^{-2} . If results are unsatisfactory, new training sequences should be generated for other values of N_B , Δt , t_i and the process of network training should be repeated.

For clarity, Fig. 4 shows graphs of the input and output signals of the two-mass system, the output signal of the neural-network model and the graph of instantaneous value of the network training error for the first 2,001 values of the indicated signals corresponding to the time of 100 seconds. As can be seen from Fig. 4, the instantaneous value of the training error does not exceed 1.5 s^{-1} .

To review the neural net structure, a network model can be constructed in Simulink. To do this, the Gensim statement with the name of the synthesized network should be used. The neural-network diagram is constructed (Fig. 5) in the appearing Simulink window by activating all elements of the neural net and connecting them with each other.

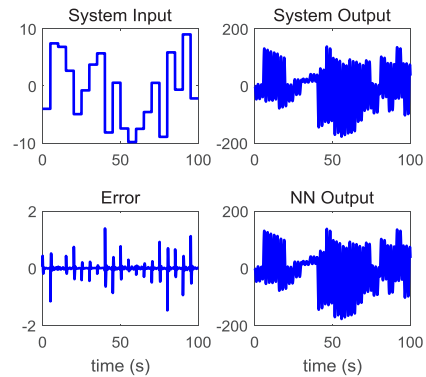

Fig. 4. Results of the network training

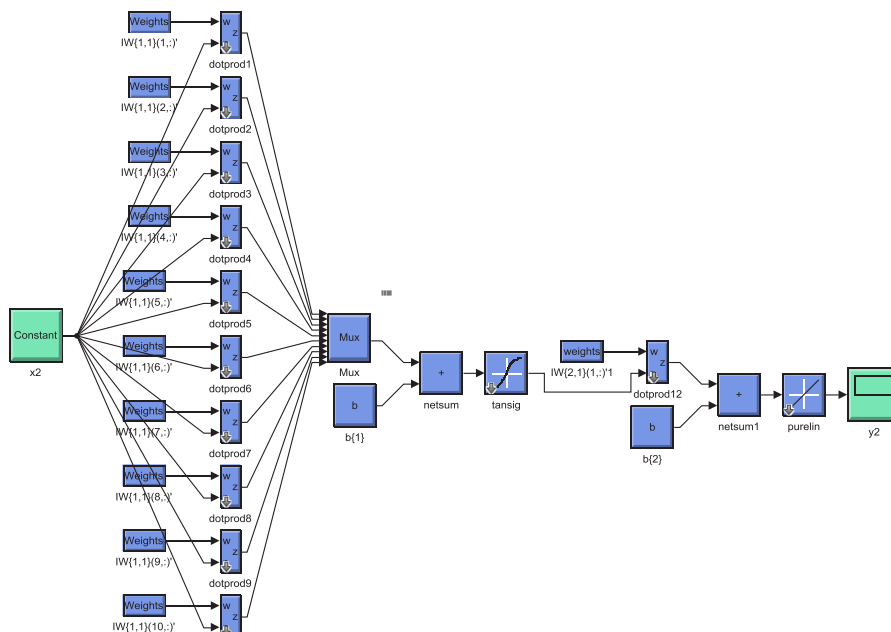

Fig. 5. Model of the neural net with direct signal transmission

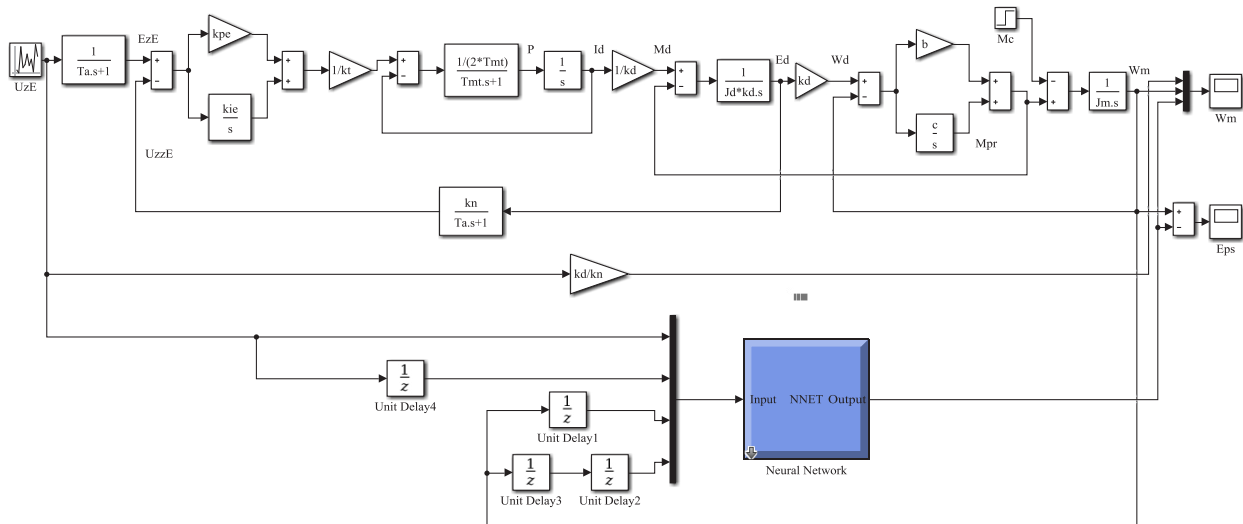

Fig. 6. The Simulink diagram for checking adequacy of the synthesized neural-network model of the two-mass system

Adequacy of the built neural-network model is checked using the diagram shown in Fig. 6. The diagram consists of a model of a two-mass electromechanical system and a Neural Network unit in which name of the synthesized neural-network model of the system is specified. The Unit Delay units are used to specify the delayed signals.

The modeling results are shown in Fig. 7, 8.

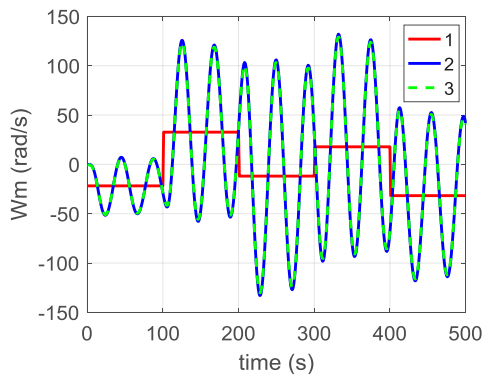

Fig. 7. Results of testing the neural-network model: the specified value of speed (1); speed at the output of the two-mass system (2); the output coordinate of the neural-network model (3)

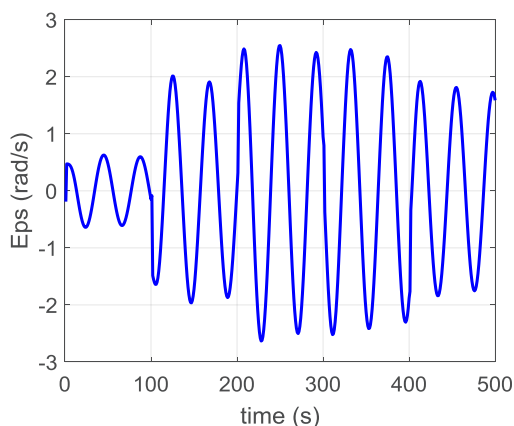

Fig. 8. The graph of identification error of the neural-network model

Graphs of the output coordinate of the system are given in Fig. 7: the mechanism speed, $\omega_m(t)$. The graph 1 (the red line) corresponds to the specified speed value, the graph 2 (the blue line) corresponds to the speed at the output of the two-mass system model, the graph 3 (the green line) corresponds to the output coordinate of the constructed neural-network model. As it can be seen, the graphs 2 and 3 practically coincide.

Fig. 8 shows the graph of difference between the indicated speeds $\varepsilon(t)$, that is, the identification error graph. It turns out from analysis of the graphs that when the mechanism speed changes from $+140 \text{ s}^{-1}$ to -140 s^{-1} , the value $\varepsilon(t)$ is in the range from $+2.6 \text{ s}^{-1}$ to -2.6 s^{-1} , that is, the identification error does not exceed 2 %.

5. Synthesizing and studying the fuzzy model of a two-mass electromechanical system represented as a fuzzy inference system

Let us consider the possibility of solving the identification problem using a fuzzy approximating system. To synthesize a fuzzy system, use the Fuzzy Logic Toolbox which is the part of MATLAB. The Fuzzy Logic Toolbox provides the ability to create fuzzy systems in a graphical mode with the use of a fuzzy inference system editor (FIS editor).

Let us construct a fuzzy system that reflects relationship between the input and output variables of a two-mass electromechanical system. When constructing a fuzzy system (as in the case of synthesis of a neural-network model), form the input sequence on the basis of the current value of the input signal of the system and the input signal delayed by one step of discreteness. In addition, use the output signal delayed by one step and two steps. Take these data for a number of characteristic points from the above example of synthesis of a neural-network model of a two-mass system. The points should cover the entire range of changes of the system input and output signals.

It is necessary to choose a fuzzy inference system of Sugeno type in the FIS editor. The system should have four inputs, so it is necessary to add three more inputs to the system with a single input signal specified by default and define their names. Let us set “ $UzE(k)$ ” for the system input signal

$U_{zE}(k)$; “ $U_{zE}(k-1)$ ” for the signal $U_{zE}(k-1)$; “ $Wm(k-1)$ ”, “ $Wm(k-2)$ ” for signals $\omega_m(k-1)$ and $\omega_m(k-2)$ and “ $Wm(k)$ ” for the system output signal, $\omega_m(k)$. The fuzzy system structure formed in the FIS Editor window is shown in Fig. 9.

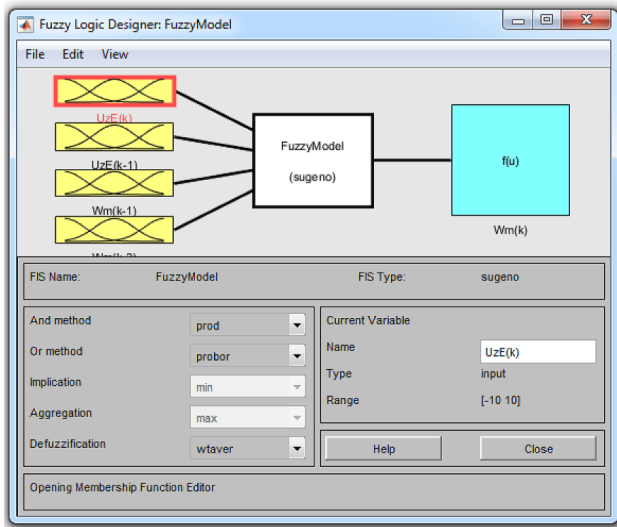

Fig. 9. The fuzzy system structure

Using the Membership Functions Editor window, specify membership functions of the variables. Start specifying and editing the membership functions with the “ $U_{zE}(k)$ ” variable (Fig. 10). Select Gaussian membership functions and set their number to 12 (for the number of characteristic points of the input sequence). Note that the result of the fuzzy model synthesis depends to a large extent on the correct choice of these points. The number of functions, their type and parameters cannot be determined in advance, so they are initially taken roughly and then refined during modeling. Their number for a two-mass electro-mechanical system should be within 10–15. Set the range of the “ $U_{zE}(k)$ ” variable from -10 to $+10$ (as noted above, the range of the input signal change is determined when calculating the system of subordinate regulation). The membership functions must be placed along the abscissa axis so that the ordinates of maxima of these functions coincide with the above-mentioned characteristic points of the “ $U_{zE}(k)$ ” variable. As indicated above, scope of the functions is specified approximately and then refined in the process of multiple modeling.

Similarly, specify and edit membership functions of the “ $U_{zE}(k-1)$ ”, “ $Wm(k-2)$ ”, “ $Wm(k-1)$ ” variables. Specify the range of “ $Wm(k-2)$ ”, “ $Wm(k-1)$ ” variables from -150 to $+150$.

It is necessary to choose constant membership functions for the “ $Wm(k)$ ” output variable ($\omega_m(k)$) and their names should be specified as corresponding numerical values “ $Wm(k)$ ”, for example 29, 43, -19.5 , etc. (Fig. 11).

Using the Rule Editor window, introduce a series of rules of the fuzzy inference system.

When synthesizing a fuzzy system, it is necessary to form a base of rules. Each rule establishes correspondence between membership functions of the input variables and the numerical value of the output variable. The number of rules is refined in the modeling process. It is recommended to form 20–25 rules for a two-mass electromechanical system. Here is an example of formation of one of them. Take

the following values from the formed input and output sequence obtained during the construction of the neural-network model of the system:

$$U_{zE}(k) = -7.17; U_{zE}(k-1) = -7.17;$$

$$\omega_m(k-1) = -61.33; \omega_m(k-2) = -61.59;$$

$$\omega_m(k) = -69.$$

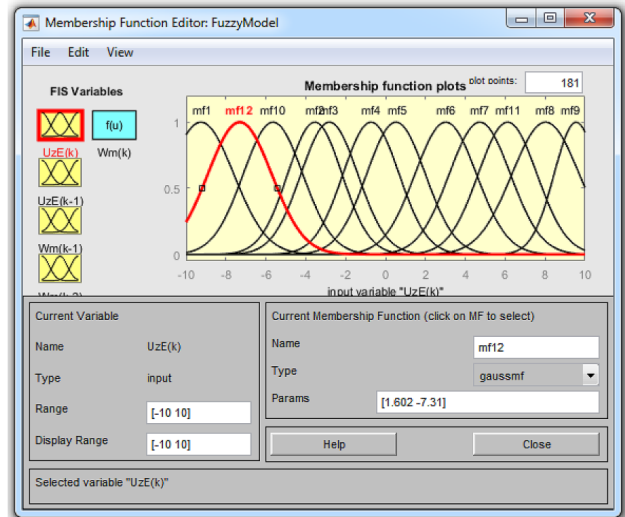

Fig. 10. Specifying the membership functions of the “ $U_{zE}(k)$ ” variable, $U_{zE}(k)$

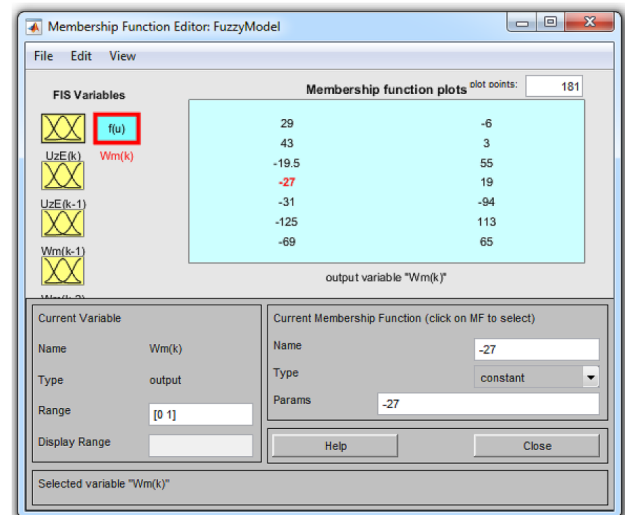

Fig. 11. Specifying the membership functions of the “ $Wm(k)$ ” variable, ($\omega_m(k)$)

The following membership functions correspond to these values:

$$U_{zE}(k) \rightarrow mf12, U_{zE}(k-1) \rightarrow mf12, Wm(k-1) \rightarrow mf1,$$

$$Wm(k-2) \rightarrow mf1, Wm(k) \rightarrow -69.$$

After entering, the rule is displayed in the Rule Editor window and will represent the following entry:

if $UzE(k)$ is *mf12* and $UzE(k-1)$ is *mf12*
 and $Wm(k-1)$ is *mf1*
 and $Wm(k-2)$ is *mf1* then $Wm(k)$ is -69 .

Similarly, another 23 rules have been formed.

Upon specifying the rules, construction of the fuzzy inference system is completed. To check identification accuracy, the Simulink scheme shown in Fig. 12 is used. The fuzzy model of a two-mass system is presented as a Fuzzy Logic Controller unit and the name of the generated fuzzy model is specified in the window of parameter specification.

The modeling results are presented in Fig. 13 where graphs of the output coordinate of a two-mass electromechanical system, $\omega_m(t)$, are given.

Analysis of graphs in Fig. 13 shows that the identification accuracy is not high and the identification error reaches 40 %. This is explained by the fact that the number of experimental points is small and parameters of the membership functions of the input variables are chosen, most likely, not in an optimal way. Achieving high accuracy of identification with the help of a fuzzy system is difficult enough. The use of fuzzy models of hybrid networks is a more promising way of solving the problem of identifying dynamic objects and systems. This issue is discussed further.

6. Synthesizing and studying the model of a two-mass electromechanical system using hybrid networks

Let us consider the possibility of using hybrid networks for identification of electromechanical systems with complex kinematic connections. Hybrid networks are implemented in the Fuzzy Logic Toolbox package of the MATLAB system in a form of adaptive neuro-fuzzy inference systems (ANFIS) [42].

First, prepare training, test and checking data. These data can be generated in different ways. Let us consider one of them which somewhat differs from the method considered above in development of a neural-network model.

Let us create a schematic diagram of the system model (Fig. 14) in the Simulink window. In this model scheme, the To Workspace unit is used to record input and output signals of the system (in this case, the task voltage, $UzE(t)$, and the mechanism speed, $\omega_m(t)$), into the workspace of the MATLAB system. It is necessary to specify the array name (for example, Uz_Wm) in the unit's window of task specification. Data and the discreteness cycle will be recorded to this array. Value of the discreteness cycle is established for the same reasons as when developing a neural-network model, so specify $\Delta t=0.05$ s. The Uniform Random Number unit is used as a signal source in the schematic diagram of Fig. 14. The same parameters should be specified in the task specification window of this unit as in development of the neural-network model of the system.

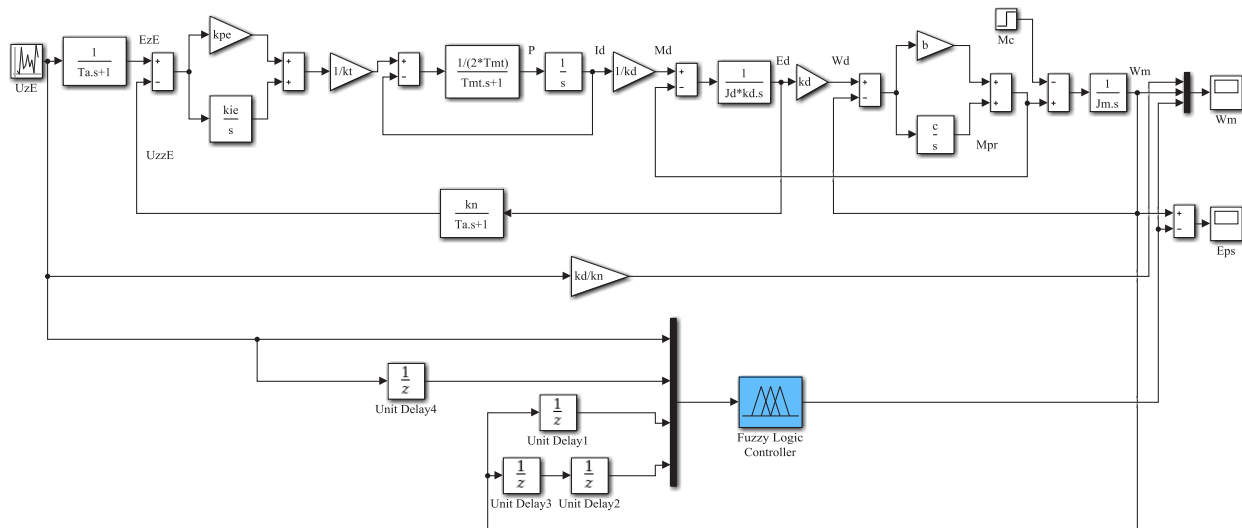

Fig. 12. The Simulink diagram for checking adequacy of the constructed fuzzy model

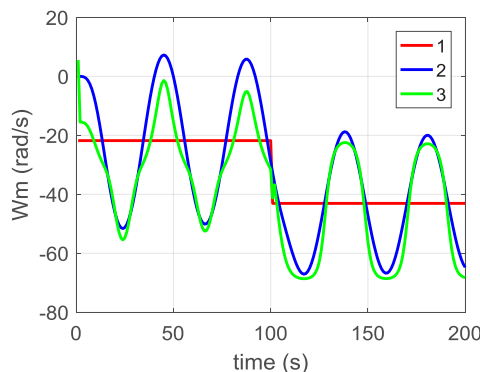

Fig. 13. The results of testing the fuzzy model: the specified speed value (1); speed at the output of the two-mass system (2); output coordinate of the fuzzy model (3)

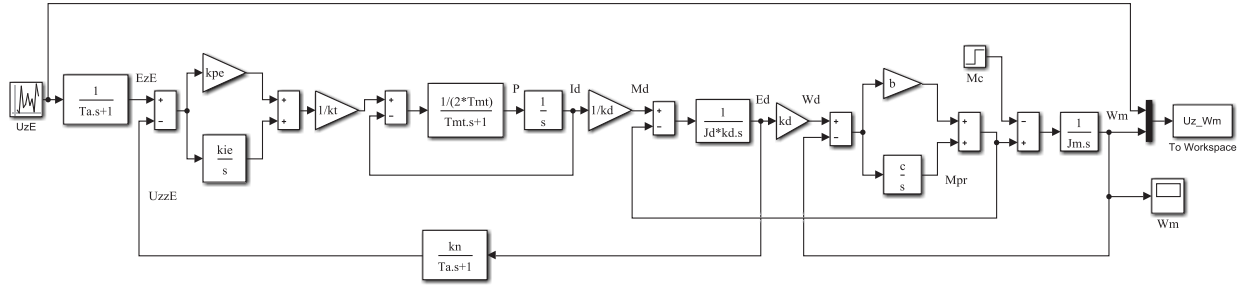

Fig. 14. The schematic diagram of a two-mass system model used for formation of the network training data

Specify the system modeling time of 100 s in the Simulink model window and perform the system modeling. The Uz_Wm array containing values of the input and output signals of the system has two columns and 2001 lines.

Save the Uz_Wm array in a file named Dat_Uz_Wm and place the file in the Fuzzy_Neural_Work folder on disk E. The Save command makes it possible to save contents of the workspace in a binary MAT file which can then be called by the Load command. However, this is unacceptable for solving this identification task since the source data file should be a normal text file with a .dat extension, so the array must be saved in ASCII format.

Next, use the first 1,000 lines of the Uz_Wm array to form the Input_Output_Training training data, the next 500 lines to form the Input_Output_Testing test data and then 500 lines to form the Input_Output_Checking check data.

As in the examples discussed above, form the input sequence on the basis of the current value of the system's input signal $U_{zE}(k)$ and the input signal delayed by one step of discreteness, $U_{zE}(k-1)$, as well as two output signals delayed by one and two steps, that is, $\omega_m(k-1)$ and $\omega_m(k-2)$, respectively.

Any text editor, such as the debugger of m-files of the MATLAB system can be used to form arrays of the above data. Text of the Form_Inp_Outp.m m-file for formation of arrays of training, testing and checking data is shown in Fig. 15. These arrays are saved in the files named Input_Output_Training.dat, Input_Output_Testing.dat and Input_Output_Checking.dat, respectively.

These arrays have 5 columns. The first 4 columns correspond to the values of the input signals of the model ($U_{zE}(k)$, $U_{zE}(k-1)$, $\omega_m(k-1)$, $\omega_m(k-2)$) and the 5th column corresponds to the value of the output signal, $\omega_m(k)$.

Next, the formed arrays are loaded into the ANFIS editor. When loading the training data in the editor window, a graph of the system output signal $\omega_m(t)$ is displayed for the above data (Fig. 16). When loading testing or checking data, this graph is supplemented by corresponding points.

To create a hybrid network, it is necessary to specify the number and type of membership functions for the input and output variables in the appropriate window that appears when clicking the Generate FIS button. These parameters cannot be determined in advance, so they are initially taken roughly and then refined in the modeling process. For this example of development of a neuro-fuzzy model of a two-mass electromechanical system, satisfactory identification accuracy was obtained when specifying 4 to 6 triangular membership functions for input variables (for the sake of clarity, structure of the fuzzy inference system with 2 functions is shown in Fig. 17). A linear function is specified as a membership function of the output variable.

```
clear;clc;echo on;
Dim_Uz_Wm=dlmread('E:\Fuzzy_Neural_Work\Uz_Wm.dat');
for i=1:3
if i==1
n=1; k=1000; j=1000;
File_Name='E:\Fuzzy_Neural_Work\Input_Output_Training.dat';
elseif i==2
n=1001; k=1500; j=500;
File_Name='E:\Fuzzy_Neural_Work\Input_Output_Testing.dat';
else
n=1501; k=2000; j=500;
File_Name='E:\Fuzzy_Neural_Work\Input_Output_Checking.dat';
end
Uz_k(1:j,1)=Dim_Uz_Wm(n:k,1);
Uz_k_1(1,1)=0;
Uz_k_1(2:j,1)=Dim_Uz_Wm(n:k-1,1);

Wm_k(1:j,1)=Dim_Uz_Wm(n:k,2);
Wm_k_1(1,1)=0;
Wm_k_1(2:j,1)=Dim_Uz_Wm(n:k-1,2);
Wm_k_2(1:2,1)=0;
Wm_k_2(3:j,1)=Dim_Uz_Wm(n:k-2,2);

Dim_Input_Output=[Uz_k Uz_k_1 Wm_k_1 Wm_k_2 Wm_k];

dlmwrite(File_Name, Dim_Input_Output, ' ');
end
```

Fig. 15. The m-file text for formation of arrays of training, testing and checking data

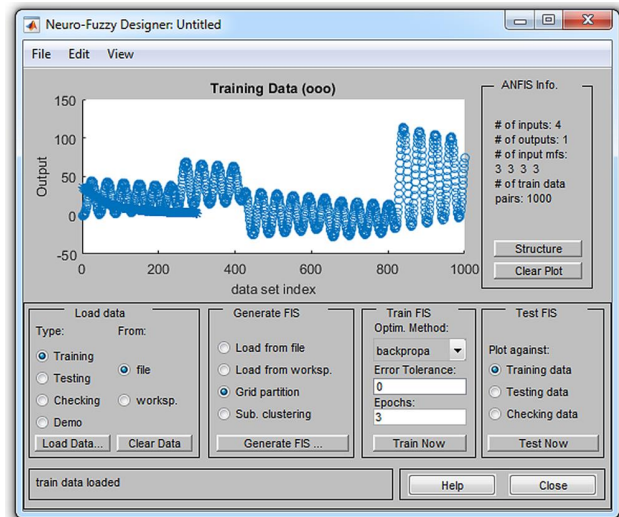

Fig. 16. The graph of the output signal of the system

The neural net is trained by the method of inverse distribution. The course of the training process is displayed in the window shown in Fig. 18. The number of training cycles after which the training error is practically unchanged is 250 to 350.

If the change of the number and type of membership functions does not result in a satisfactory accuracy of identi-

fication, it is necessary to form new training data and repeat the training process.

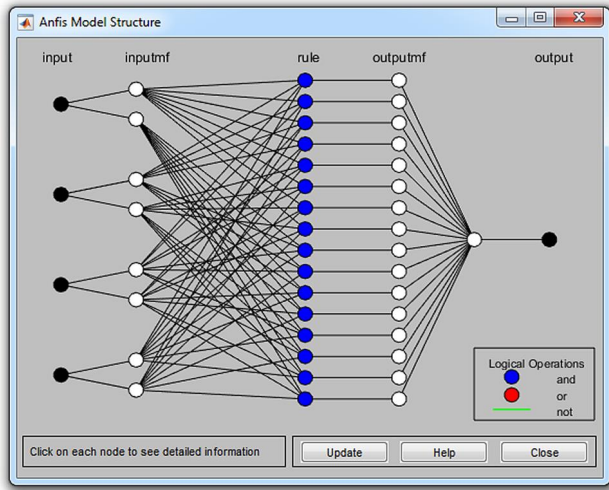

Fig. 17. Structure of the created hybrid network

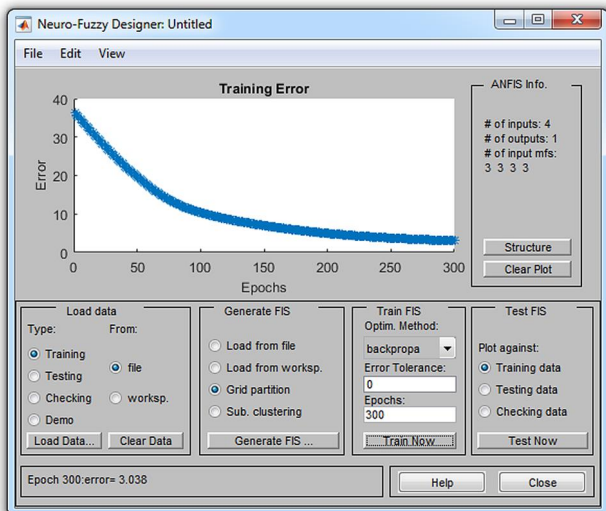

Fig. 18. The graphs of change of the training and checking errors

Because the fuzzy inference system of the Sugeno type is the model of the hybrid network in the MATLAB system, then, if necessary, its correction and study can be done by means of the FIS editor.

With the help of the Test FIS button, the created network can be checked along with displaying graphs for making training, testing and checking samples. These graphs were plotted in the course of the study and it was found that values of signals at the output of the two-mass electromechanical system and the output of the fuzzy model of the hybrid network coincided almost completely. However, testing in the ANFIS editor is performed using the input signals that were used in the network training. For a more accurate checking of the results of identification of a two-mass electromechanical system by means of a hybrid network, the schematic diagram shown in Fig. 12 can be used. In doing this, it is necessary to specify name of the generated neuro-fuzzy inference system in the Fuzzy Logic Controller unit window in which param-

eters are specified. The modeling results are presented in Fig. 19, 20.

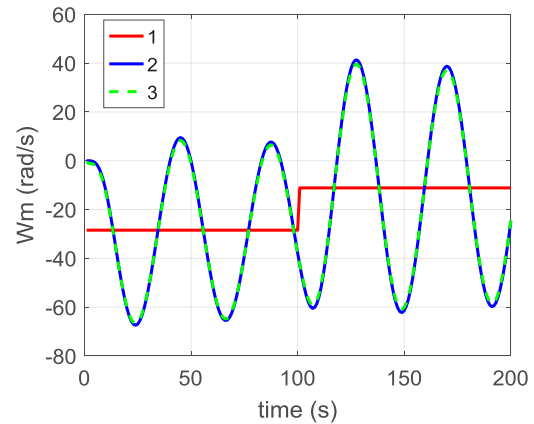

Fig. 19. The results of checking the neuro-fuzzy model: the specified speed value (1); speed at the output of the two-mass system model (2); output coordinate of the neuro-fuzzy model (3)

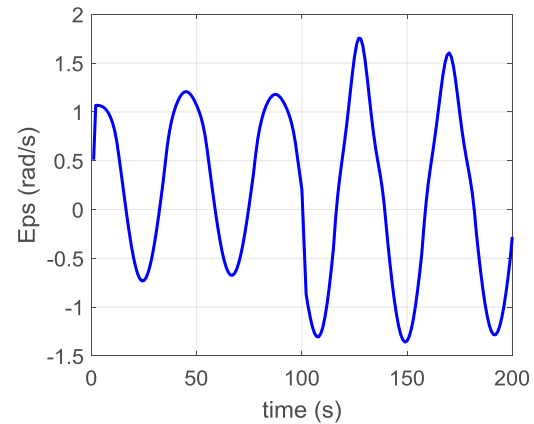

Fig. 20. The graph of identification error of the neuro-fuzzy model

Fig. 19 shows the graphs of the output coordinate of the two-mass electromechanical system, $\omega_m(t)$. Graph 1 corresponds to the specified speed value, graph 2 corresponds to speed at the output of the model of the two-mass system and graph 3 corresponds to the output coordinate of the synthesized neuro-fuzzy model. As can be seen, graphs 2 and 3 practically coincide.

Fig. 20 shows the graph of difference of the above speeds, $\epsilon(t)$, that is, the graph of the identification error. As it follows from analysis of the graphs, when the mechanism speed changes from $+40 \text{ s}^{-1}$ to -60 s^{-1} , the value of $\epsilon(t)$ is in the range from $+1.5 \text{ s}^{-1}$ to -1.5 s^{-1} , that is, identification error does not exceed 4 %.

7. Discussion of the results obtained in studying synthesis of neural-network and fuzzy models of multimass electromechanical systems

Effectiveness of the created systems of real object control depends to a large extent on quality of the mathematical models applied. They should most fully reflect properties of the object under study and be convenient for implementation

of control algorithms. The lack of complete information on operation conditions and properties of the objects necessitates application of an adaptive approach to their control which allows the use of simplified, in particular, linear models. However, such an approach may not provide necessary qualitative control indicators in solving practical problems since the model constructed on the basis of assumption of the system linearity may not reflect its actual properties.

A possibility of using artificial neural nets for identification of multimass electromechanical systems was considered in this study as an alternative to the conventional approaches to identification. Construction of mathematical models of multimass electromechanical systems presents considerable difficulties because of the lack of exact quantitative characteristics of all elements and connections. Knowledge of the exact system structure and parameters is not a prerequisite when using neural-network identification. The system model in a form of a two-layer neural net of direct propagation with delayed input and output signals is constructed based on the known input signals and the signals measured at the system output. As a result of the study, it has been established that neural nets can be successfully applied to construct models of multimass electromechanical systems (Fig. 7). This is due to the fact that the neural-network models are based on approximation of the nonlinear operator of transformation of input signals into output signals by some system of basis functions. In this case, the identification object is represented as a neural net containing one or more hidden layers in addition to the input and output layers. Each layer consists of a certain number of neurons that implement the specified basis function. The purpose of identification consists in the choice of the network structure and training based on presentation of training couples. Measured values of the input variables and corresponding output variables serve as these pairs. As a result of the studies conducted using the MATLAB system, parameters that have the most significant impact on identification quality were identified and recommendations given on the optimal value of these parameters in order to achieve the highest accuracy of identification. Type of the neural net, number of neurons in the hidden layer, number of delay cycles for the input and output signals at the input of the neural model, parameters of the training data were determined for the neural-network model. Accuracy of identification was 2 %.

A model of a two-mass electromechanical system was synthesized with the use of methods of present-day technology, that is, the technology of fuzzy modeling. As noted, conventional methods of model construction do not give satisfactory results when initial description of the problem to be solved is inaccurate or incomplete. The fuzzy methods are specially oriented on construction of the models that take into consideration incompleteness and inaccuracy of initial data. When the fuzzy model of a two-mass electromechanical system was constructed, structure of the fuzzy inference system, number and parameters of membership functions of the input signals and the signal at the output of the system, number and content of fuzzy inference rules were determined. However, the results of modeling the fuzzy model (Fig. 13) have shown that the identification accuracy was not high. It is rather difficult to achieve high accuracy of identification using a fuzzy system since it is impossible to determine in advance the required number and structure of the fuzzy inference rules as well as optimal parameters of membership functions for input variables.

The study results show (Fig. 19) that the promising line of solving the problem of identification of electromechanical systems with complex kinematic connections consists in the use of fuzzy models of hybrid networks implemented as adaptive neuro-fuzzy inference systems. This is determined by the fact that hybrid networks are the structures that combine the best properties of methods of neural-networks and fuzzy logic and at the same time they are free from their problems. Hybrid networks are the decision making systems that realize the idea of fuzzy cogitation together with the ability to training inherited from the neural nets. In the process of synthesis of the model of a two-mass electromechanical system in a form of a hybrid network, the number and parameters of the membership functions for the input variables and the number of hybrid network training cycles ensuring accuracy of identification of 4 % were determined.

Disadvantages of constructing models of multimass electromechanical systems with application of neural-network technologies and fuzzy modeling are as follows. The method of designing neural-network, fuzzy, and neuro-fuzzy models is based more on intuition than on existing laws. Until now, an algorithm for calculating the number of network layers and the number of neurons in each layer for specific applications is unknown for neural-network models. Orders of delays of incoming and outgoing signals are pre-selected on the basis of a priori knowledge about the object of identification (if any) and the researcher's experience and then refined experimentally in the process of constructing the neuro-model through multiple modeling. The same applies to the choice of the number and structure of fuzzy inference rules, determination of parameters of the membership functions of the input variables and other parameters during synthesis of fuzzy and neuro-fuzzy models. Synthesis of neural-network, fuzzy and neuro-fuzzy models requires a deep knowledge and high qualification of the researcher. In addition, the choice of parameters requires a considerable amount of time.

However, the use of neural-network technologies and fuzzy logic opens up wide opportunities for controlling complex multimass systems. Knowledge of exact system structure and parameters is not a prerequisite for implementation of control algorithms since the model of the system in a form of a neural net or a system of neuro-fuzzy inference is built on the basis of known input signals and signals measured at the system output.

It is advisable to continue studies on identification of multimass electromechanical systems taking into consideration nonlinear dependences of external friction and clearance in kinematic links, external perturbing effects and obstacles in measuring the regulated coordinates.

The study results can be used in synthesis of regulators for systems with complex kinematic connections to ensure high system performance.

8. Conclusions

1. A neural-network model of the electromechanical system with complex kinematic connections was synthesized by the NNTool interface of the MATLAB system. A two-layer neural-network has been created and the optimal number of hidden neurons was determined (8–12 neurons) which is the main factor for ensuring high accuracy of identification. It was established that the number of delay cycles for the input and output signals at the input of the neuromodel should be

within the range of 1–2 and 2–5, respectively. By means of varying the training data parameters in a wide range, values were defined that provide minimum errors of the neural-network training. The number of training data must be at least 8,000–100,000, the interval between successive data reading must be 0.03–0.05 s and the training data must contain only the acceleration phases. Computer modeling has shown that the identification error did not exceed 2 %.

2. A possibility of solving the problem of system identification using an approximating fuzzy system using the Fuzzy Logic Toolbox package was considered. Structure of a fuzzy system of Sugeno type with 4 input signals was established. It has been found by means of multiple simulations that the optimum number of membership functions of the input signals and the signal at the output of the system was within 10

to 15. A base of the fuzzy inference rules was formed. The number of rules should be 20 to 25. As a result of the study, it was found that an instant identification error reached 40 %, that is, it is difficult to obtain high accuracy of identification using a fuzzy system.

3. A hybrid network was synthesized as a model of two-mass electromechanical system with the use of the ANFIS editor of the Fuzzy Logic Toolbox package. The order of formation of the hybrid network training sequence was given. It was determined that satisfactory identification accuracy is achieved with 4 to 6 triangular membership functions for input variables. The number of training cycles after which the training error was virtually unchanged was 250 to 350. The error of identification of a two-mass electromechanical system using a hybrid network did not exceed 4 %.

References

1. Akimov L. V., Kolotilo V. I., Markov V. S. *Dinamika dvuhmassovykh sistem s netraditsionnymi regulyatorami skorosti i nablyudatelyami sostoyaniya*. Kharkiv: HGPU, 2000. 93 p.
2. Kotlyarov V. O., Osichev A. V. O rezul'tatah resheniya zadach stabilizatsii sistem s otritsatel'nym vyazkim treniem posredstvom primeneniya nablyudayuschih ustroystv // *Visnyk Natsionalnoho tekhnichnoho universytetu «Kharkivskiy politekhnichnyi instytut»*. 2010. Issue 28. P. 242–248.
3. Bahatokryterialnyi syntezy neliniynykh robstnykh elektromekhanichnykh system / Kuznetsov B. I., Nikitina T. B., Kolomiets V. V., Voloshko O. V., Kobylanskyi B. B. // *Visnyk Natsionalnoho tekhnichnoho universytetu «Kharkivskiy politekhnichnyi instytut»*. 2017. Issue 27 (1249). P. 58–61.
4. Pivniak H. H., Beshta O. S., Tulub S. B. Tsyfrova identyfikatsiya parametriv elektromekhanichnykh system v zadachakh enerho- i resursozberezhennia: monohrafiya / H. H. Pivniak (Ed.). Dnipropetrovsk: Natsionalnyi hirnychiy universytet, 2004. 197 p.
5. Balyuta S., Kopilova L., Klimenko J. Identification of the parameters of electro-mechanical system model based on genetic algorithms // *Naukovi pratsi NUKhT*. 2013. Issue 49. P. 88–97.
6. Saushev A. V., Trojan D. I. Identification of electric drives of port reloading cars // *Vestnik Gosudarstvennogo universiteta morskogo i rechnogo flota imeni admirala S. O. Makarova*. 2015. Issue 5 (33). P. 169–183. doi: <https://doi.org/10.21821/2309-5180-2015-7-5-169-183>
7. Vodovozov A. M., Elyukov A. S. Algorithms of parametrical identification of electromechanical systems protected against hindrance // *Izvestiya vysshikh uchebnykh zavedeniy*. 2009. Vol. 52, Issue 12. P. 40–43.
8. Luczak D., Zawirski K. Parametric identification of multi-mass mechanical systems in electrical drives using nonlinear least squares method // *IECON 2015 - 41st Annual Conference of the IEEE Industrial Electronics Society*. 2015. doi: <https://doi.org/10.1109/iecon.2015.7392730>
9. Nouri K., Loussifi H., Braiek N. B. A comparative study on the identification of the dynamical model of multi-mass electrical drives using wavelet transforms // *International Journal of Systems Science*. 2014. Vol. 45, Issue 11. P. 2223–2241. doi: <https://doi.org/10.1080/00207721.2013.766772>
10. Villwock S., Pacas M. Application of the Welch-Method for the Identification of Two- and Three-Mass-Systems // *IEEE Transactions on Industrial Electronics*. 2008. Vol. 55, Issue 1. P. 457–466. doi: <https://doi.org/10.1109/tie.2007.909753>
11. Zoubek H., Pacas M. An identification method for multi-mass-systems in speed-sensorless operation // *2011 IEEE International Symposium on Industrial Electronics*. 2011. doi: <https://doi.org/10.1109/isie.2011.5984447>
12. Zoubek H., Pacas M. A method for speed-sensorless identification of two-mass-systems // *2010 IEEE Energy Conversion Congress and Exposition*. 2010. doi: <https://doi.org/10.1109/ecce.2010.5618431>
13. Luczak D., Nowopolski K. Identification of multi-mass mechanical systems in electrical drives // *Proceedings of the 16th International Conference on Mechatronics - Mechatronika 2014*. 2014. doi: <https://doi.org/10.1109/mechatronika.2014.7018271>
14. Parameter estimation of two-mass mechanical loads in electric drives / Saarakkala S. E., Leppinen T., Hinkkanen M., Luomi J. // *2012 12th IEEE International Workshop on Advanced Motion Control (AMC)*. 2012. doi: <https://doi.org/10.1109/amc.2012.6197104>
15. Saarakkala S. E., Hinkkanen M. Identification of Two-Mass Mechanical Systems Using Torque Excitation: Design and Experimental Evaluation // *IEEE Transactions on Industry Applications*. 2015. Vol. 51, Issue 5. P. 4180–4189. doi: <https://doi.org/10.1109/tia.2015.2416128>
16. Abou-Zayed U., Ashry M., Breikin T. Experimental open-loop and closed-loop identification of a multi-mass electromechanical servo system // *Proceedings of the Fifth International Conference on Informatics in Control, Automation and Robotics Service*. 2008. P. 188–196. doi: <https://doi.org/10.5220/0001502601880193>
17. Konev V. V. Improved algorithms of teaching of neuronet system of authentication of the safe state of immobile objects of systems of critical application // *Systemy obrobky informatsiyi*. 2016. Issue 3. P. 241–245.

18. Horbiichuk M. I., Humeniuk T. V. Neural network identification technology for manufacturing operations of drilling rig // *Naukovyi visnyk NHU*. 2017. Issue 3. P. 107–113.
19. Lyashenko S. A. Postroenie modeli nelineynogo dinamicheskogo obekta na osnove modifitsirovannoy radial'no-bazisnoy seti // *Vestnik Hersonskogo natsional'nogo tekhnicheskogo universiteta*. 2007. Issue 4 (27). P. 33–35.
20. Kondratenko Yu. P., Hordyenko E. V. Neiromerzhevyi pidkhid do rishennia zadachi identyfikatsiyi nestatsionarnykh parametriv tekhnolohichnykh obektiv // *Visnyk NTU «KhPI»*. Tematychnyi vypusk: Informatyka i modeliuвання. 2010. Issue 21. P. 102–109.
21. Continuous-Time Neural Identification for a 2 DOF Vertical Robot Manipulator / Jurado F., Flores M. A., Santibanez V., Llama M. A., Castaneda C. E. // 2011 IEEE Electronics, Robotics and Automotive Mechanics Conference. 2011. doi: <https://doi.org/10.1109/cerma.2011.20>
22. Castañeda C. E., Esquivel P. Decentralized neural identifier and control for nonlinear systems based on extended Kalman filter // *Neural Networks*. 2012. Vol. 31. P. 81–87. doi: <https://doi.org/10.1016/j.neunet.2012.03.005>
23. System identification using artificial neural network / Nidhil K. J., Sreeraj S., Vijay B., Bagyaveereswaran V. // 2015 International Conference on Circuits, Power and Computing Technologies [ICCPCT-2015]. 2015. doi: <https://doi.org/10.1109/ic-cpct.2015.7159360>
24. Zhang J., Li Y., Wu X. Neural network identification and control for nonlinear dynamic systems with time delay // 2015 34th Chinese Control Conference (CCC). 2015. doi: <https://doi.org/10.1109/chicc.2015.7260183>
25. Ren X. M., Rad A. B. Identification of Nonlinear Systems With Unknown Time Delay Based on Time-Delay Neural Networks // *IEEE Transactions on Neural Networks*. 2007. Vol. 18, Issue 5. P. 1536–1541. doi: <https://doi.org/10.1109/tnn.2007.899702>
26. Neural identifier for unknown discrete-time nonlinear delayed systems / Alanis A. Y., Rios J. D., Arana-Daniel N., Lopez-Franco C. // *Neural Computing and Applications*. 2016. Vol. 27, Issue 8. P. 2453–2464. doi: <https://doi.org/10.1007/s00521-015-2016-7>
27. Viattchenin D. A., Starovoitov V. V. Objects Identification Through Fuzzy Inference System // *Shtuchnyi intelekt*. 2010. Issue 3. P. 312–321.
28. Udovenko S. G., Dibe G., Perepelitsa V. I. Method of fuzzy identification of nonlinear objects of digital control // *Zbirnyk naukovykh prats Kharkivskoho universytetu Povitrianykh Syl*. 2008. Issue 3 (18). P. 131–134.
29. Horbiychuk M., Humeniuk T., Povarchuk D. Fuzzy Identification of Technological Objects // *Energy Engineering and Control Systems*. 2015. Vol. 1, Issue 1. P. 35–42. doi: <https://doi.org/10.23939/jeecs2015.01.035>
30. Dovžan D., Škrjanc I. Recursive fuzzy c-means clustering for recursive fuzzy identification of time-varying processes // *ISA Transactions*. 2011. Vol. 50, Issue 2. P. 159–169. doi: <https://doi.org/10.1016/j.isatra.2011.01.004>
31. Bertone A. M. A., Martins J. B., Yamanaka K. Black-Box Fuzzy Identification of a Nonlinear Hydrogen Fuel Cell Model // *TEMA (São Carlos)*. 2018. Vol. 18, Issue 3. P. 405. doi: <https://doi.org/10.5540/tema.2017.018.03.405>
32. Kim Y., Langari R., Hurlebaus S. MIMO fuzzy identification of building-MR damper systems // *Journal of Intelligent and Fuzzy Systems*. 2011. Vol. 22, Issue 4. P. 185–205. doi: <http://doi.org/10.3233/IFS-2011-0482>
33. Bottura C. P., de Oliveira Serra G. L. An algorithm for fuzzy identification of nonlinear discrete-time systems // 2004 43rd IEEE Conference on Decision and Control (CDC) (IEEE Cat. No.04CH37601). 2004. doi: <https://doi.org/10.1109/cdc.2004.1429670>
34. Fuzzy Identification of the Time- and Space-Dependent Internal Surface Heat Flux of Slab Continuous Casting Mold / Wan G., Wan S., Chen H., Wang K., Lv C. // *Journal of Heat Transfer*. 2018. Vol. 140, Issue 12. P. 122301. doi: <https://doi.org/10.1115/1.4040955>
35. Fuzzy Identification Based on T-S Fuzzy Model and Its Application for SCR System / Zeng F., Zhang B., Zhang L., Ji J., Jin W. // *Mechanical Engineering and Control Systems*. 2016. P. 293–297. doi: https://doi.org/10.1142/9789814740616_0064
36. Sorokina I. V., Tokareva E. V., Sorokin R. V. Identifikatsiya nelineynykh obektov s ispol'zovaniem adaptivnykh nechetkikh modeley // *Tekhnologiya priborostroeniya*. 2015. Issue 2. P. 35–39.
37. Subbotin S. A. The Identification of Neuro-Fuzzy Models for Technical Diagnosis Problem Solving // *Shtuchnyi intelekt*. 2011. Issue 1 (33). P. 251–254.
38. Agamalov O. N. Otsenka tekhnicheskogo sostoyaniya elektrooborudovaniya v real'nom mashtabe vremeni metodom neyro-nechetkoy identifikatsii // *ExponentaPro: Matematika v prilozheniyah*. 2003. Issue 12. P. 36–44.
39. Neural identification of rock parameters using fuzzy adaptive learning parameters / Liang Y. C., Feng D. P., Liu G. R., Yang X. W., Han X. // *Computers & Structures*. 2003. Vol. 81, Issue 24-25. P. 2373–2382. doi: [https://doi.org/10.1016/s0045-7949\(03\)00303-1](https://doi.org/10.1016/s0045-7949(03)00303-1)
40. Yu W., Li X. Fuzzy Identification Using Fuzzy Neural Networks With Stable Learning Algorithms // *IEEE Transactions on Fuzzy Systems*. 2004. Vol. 12, Issue 3. P. 411–420. doi: <https://doi.org/10.1109/tfuzz.2004.825067>
41. Serra G. L. O., Bottura C. P. An IV-QR Algorithm for Neuro-Fuzzy Multivariable On-line Identification // 2005 IEEE International Conference on Systems, Man and Cybernetics. 2005. doi: <https://doi.org/10.1109/icsmc.2005.1571589>
42. D'yakonov V. P., Kruglov V. V. MATLAB 6.5 SR1/7/7 SR1/1 SR2 + Simulink 5/6: Instrumenty iskusstvennogo intellekta i bioinformatiki: seriya "Biblioteka profesionala". Moscow: SOLON-PRESS, 2006. 456 p.