

Для шестипуансонних пресових установок розроблений диференціальний метод вимірювання високих квазігидростатических тисків шляхом побудови характеристик навантаження  $p=f(Q)$ , де  $p$  – значення тиску в квазігидростатичній комірі високого тиску,  $Q$  – зусилля преса. Тиск в осередку вимірюється з використанням вимірювання різниці температури поліморфних перетворень в  $Co(\alpha \rightarrow \beta)$  і  $Fe(\alpha \rightarrow \gamma)$ , плавлення  $Ag$  і  $Cu$ ; вимірювання проведені методом резистометрії. В якості вихідних даних використані, добре вивчені раніше на  $p$ ,  $T$ -діаграмах лінії фазових переходів в залізі і кобальті в діапазонах  $p=4-7$  ГПа і  $T=500-700$  °С. Для цього ж діапазону тисків при температурі 1150–1400 °С криві плавлення міді і срібла.

База вихідних даних представлена в аналітичному вигляді і дозволила застосувати її для визначення тиску в комірі при високих температурах за значеннями величин диференціальної різниці температур  $\Delta T_d$ . Експериментально виміряно для розроблених в даній роботі датчиків  $Co\alpha-\beta-Fe\alpha-\gamma$  і  $Ag/Al$ – $Si/Al$ ; описані особливості складання диференціальних датчиків та їх електричних з'єднань для проведення процесу вимірювання величин  $\Delta T_d$ . Розроблено конструкції комірок високого тиску для проведення експериментів по вимірюванню  $\Delta T_d$  за допомогою термопар та схеми фіксування зміни опору датчиків при фазових перетвореннях.

Застосована методика дозволяє визначати тиск в квазігидростатичних комірках шестипуансонних апаратів шляхом побудови характеристик навантаження. Основними перевагами розробленого методу вимірювання квазігидростатических тисків за допомогою резистометрії є його відносна простота та значне збільшення точності визначення тиску. Точність зростає через взаємне знищення поправок впливу тиску і паразитних складових на величину термо-ЕРС термопар при використанні резистивних датчиків  $Co-Fe$  і  $Ag-Si$ .

Отримані дані можна використовувати для контролю і визначення тисків в комірках шестипуансонних пресових установок з діаметром плунжера 560–950 мм

Ключові слова: високий квазігидростатических тиск, шестипуансонний апарат високого тиску, резистивний датчик тиску

# DETERMINING HIGH QUASI-HYDROSTATIC PRESSURE UP TO 7 hPa AT A TEMPERATURE TO 1,400 °C USING RESISTIVE SENSORS

**S. Ivakhnenko**

Doctor of Technical Sciences, Professor,  
Corresponding Member of NAS of Ukraine,

Head of Department\*

E-mail: Serg1304@bigmir.net

**V. Lysakovskiy**

PhD, Senior Researcher\*\*

**O. Savitskiy**

Postgraduate student\*\*

E-mail: Savitskiy91@gmail.com

**A. Burchenia**

Junior Researcher\*\*

E-mail: burchenia@gmail.com

\*Department of

Monocrystalline Superhard Materials\*\*\*

\*\*Department of

Superhard Single Crystal Materials\*\*\*

\*\*\*V. Bakul Institute for Superhard Materials of the National Academy of Sciences of Ukraine Avtozavodska str., 2, Kyiv, Ukraine, 04074

## 1. Introduction

High quasi-hydrostatic pressures are widely used in science and industry for the manufacture of different superhard materials [1]. To create the quasi-hydrostatic compression conditions, it is required to apply high-pressure units (HPU), most of which operate on the principle of a compressible gasket [2]. When operating HPU of such types as “belt”, “toroid”, “leopard”, a six-punch HPU of cubic type, etc. [3], it is important to build a load characteristic. Its use makes it possible to estimate the level of pressures in a working cell, as well as to determine the compression efficiency of the container. To determine the values for pressure in the working cells of such units, the load characteristics are used that are built at room temperature based on the fixed points of transformations in bismuth,

thallium, barium, as well as in some semiconductors [4]. Such a calibration shows that the pressure magnitudes in this case significantly differ from the values for pressure, created at the same efforts of loading HPU under a hot condition. Thus, at a temperature of 1,000–1,400 °C, pressure values for the high-pressure cells can exceed the pressure, determined from a load characteristic at ambient temperature, by 30–40 % [5]. This circumstance is of special importance when conducting research that necessitates precise control over pressure, for example, when growing the structurally-perfect single crystals of diamonds on the seed. The scientific literature [6, 7] has so far lacked data on earlier research into the construction of load characteristics for six-punch HPU aimed at determining pressure at elevated temperature, as well as its calibration, which renders special relevance to carrying out such a study.

---

## 2. Literature review and problem statement

---

According to a well-known procedure [6], a load characteristic is constructed by registering a change in the electrical resistance of reference materials, predetermined by the progress of phase transitions at high pressure. Typically, the reference materials include bismuth, thallium, barium, as well as some semiconductors (PbTe, PbSe) [4]. Special feature of the procedure reported in work [6] is that it is necessary to determine phase transitions in the reference materials at room temperature. This condition does not make it possible to account for the increase in pressure caused by the thermal expansion of a cell's materials during its resistive heating [7]. According to data set forth in [7], a pressure increase could amount to 30–40 % depending on a cell's materials. The research results, described in [7], show that the magnitudes for pressure in this case may significantly differ from values obtained under the same efforts for loading HPU in a hot condition. Deviations from the standard values for a load-carrying characteristic, as a result of the influence of temperatures on the order of 1,000–1,400 °C, could reach 30–40 %. In this regard, it is evident that the application of this approach does not make it possible to correctly estimate values for high pressures under the action of high temperatures. The reason for this is that in the case of using standard calibrants there is no correction for the influence of high temperatures. And building correcting characteristics at high temperatures for these calibrants requires the development of additional procedures that should take into consideration the multi-level character of phase transitions, which is an extremely tedious and inexpedient task. Particularly important is the construction of a load characteristic for the six-punch HPU of cubic type, since no information is available for HPU of this type. This fact is predetermined by that due to their design features, it is possible to measure high pressures at room temperature in the cells of a given unit only up to ~4 hPa [5, 8]. Given this, a manufacturer of six-punch high-pressure units recommends loading these devices with a parallel heating of the container [8]. Failure to comply with this requirement leads to the destruction of hard-alloyed punches used for compression processes at HPU unloading.

There are also great difficulties when building a measurement circuit for the acquired data when the contacts are removed from a high-pressure container. In most cases, the ends of sensors are connected inside a compressed gasket [9]. However, when operating a six-punch HPU, using this method is not possible. The reason for this is the fact that applying such a wiring circuit disrupts the measurement chain due to large values for elastoplastic deformation in places where a pressed gasket leaks.

Building load characteristics at ambient temperature for some types of single-stage units is not possible at pressure values above 3–4 hPa. Thus, operating Chinese six-punch presses implies that when reaching such magnitudes for pressures at the specified level it is necessary to ensure the heating of containers by raising the temperature in a cell to 600–1 000 °C. Heating the containers in such a way is required to improve the plasticity and fluidity of materials of containers, forming a compressible HPU gasket when loading the unit. In this connection, a manufacturer of six-punch high-pressure equipment does not recommend operation without heating the container [8]. A failure to comply with this requirement leads to the destruction of hard-alloyed punches used for compression processes at HPU unloading. For this reason, the values for pressure above ~4 hPa are uncontrolled and uncertain when operating the equipment of this type.

To build a load characteristic at high temperatures, one can use the thoroughly studied equilibrium lines of polymorphic transformations and melting in their phase  $p$ ,  $T$ -diagrams of such elements as Bi, Fe, Si, Cu, Ag, Au [4]. In this case, there is a need to measure temperature; the accuracy of such measurements influences the determination of pressure values; they depend on the degree of influence of pressure on the thermocouples' thermo-EMF. In addition, the thermocouple indicators also depend on the magnitudes for parasitic EMF arising in cases where the connection of thermocouple sensors' is executed through hard-alloyed punches and other metallic parts, which ensure loading and compaction of the container. For the thermocouples chromel–alumel and platinum–platinum rhodium, such deviations in readings due to application of high pressures could reach the order of ~50° at  $p=5–6$  hPa and  $T=1,000–1,400$  °C [10, 11]. It is extremely difficult to account for the parasitic components of thermo-EMF under such conditions.

A considerably greater accuracy in determining pressure using phase transitions at high temperatures is achieved when one applies a differential method [12]. Underlying it is determining the pressures based on a difference between the phase transitions of two selected elements in the required intervals  $p$  and  $T$  [16–18]. The application of a differential pressure measurement method has up to now employed a differential thermal analysis (DTA). This method implies the use of samples with a volume of several mm<sup>3</sup> in order to register phase transformations in them by using thermocouples, which make it possible to define thermal effects within them [6, 8]. A DTA procedure is quite complicated structurally and time-consuming; for this reason, it has not been widely applied to determine pressure by a differential technique in quasi-hydrostatic equipment that work on the principle of a compressible gasket.

In this regard, it appears appropriate to devise a procedure that would make it possible to facilitate determining the values for high pressures in a cell exposed to high temperatures. Determining high pressures is particularly important to obtain superhard high-quality materials when using a six-punch HPU.

---

## 3. The aim and objectives of the study

---

The aim of this study is to devise a procedure for measuring pressure, taking into consideration the influence of high temperatures, in a multi-punch HPU, using CS-VII as an example [8]. This will make it possible to more accurately estimate the conditions inside a cell of high pressure, which would enable a research under controlled conditions, as well as improve the quality of production of superhard materials.

To accomplish the aim, the following tasks have been set:

- to design a high-pressure sensor wiring circuit, exposed to high temperatures;
- to build a load characteristic for the six-punch HPU CS-VII and to estimate the degree of error when using the proposed procedure for determining pressure.

---

## 4. A method to study phase transitions under high pressure

---

A resistometry procedure makes it possible to register the phase transformation temperatures necessary for determining the pressure by a differential technique at high

temperatures for sensors that represent the pairs of elements Co–Fe and Ag–Cu.

A principal diagram of the high-pressure unit of model CS-VII is shown in Fig. 1. The hard-alloyed punches of the pressing unit of model CS-VII (Fig. 1) represent truncated tetrahedral pyramids with a flat pushing pad of 46x46 mm and four sloping facets. These facets are sequentially adjacent to each side of the pushing plane at an angle of 46°, followed by a change in the angle of up to 41.5° to the punch cylindrical axis.

The container of the pressing unit CS-VII (Fig. 2), designed to compress a high-pressure cell, took the form of a cube with a side of 58 mm; it was made from pressed pyrophyllite. The container had a cylindrical hole with a diameter 44 mm to hold a working high-pressure cell.

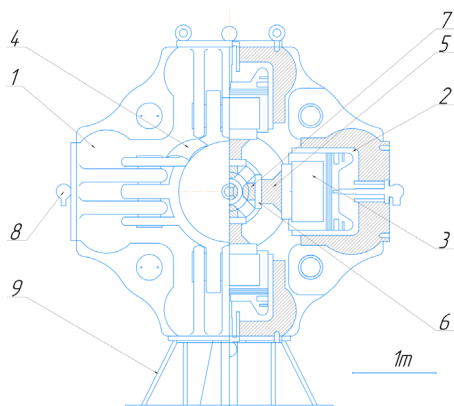

Fig. 1. General view of the pressing unit CS-VII [6]:

- 1 – bed of the press, consisting of six plunger parts of the body, ensuring the displacement of punches along three mutually perpendicular three directions;
- 2 – cylinder to create high pressure of a working substance (oil);
- 3 – piston;
- 4 – protective screen for a workspace;
- 5 – supporting plates;
- 6 – cooling sleeve of the pushing punch;
- 7 – hard-alloyed punch;
- 8 – valve to feed oil;
- 9 – support rack

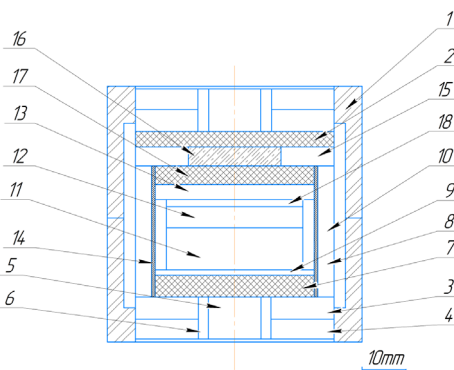

Fig. 2. Schematic of a high-pressure cell in a cubic container of the six-punch HPU CS-VII for determining values for transformations in sensors Co–Fe or Ag–Cu: 1 – semi-cubes 58x58x29 mm a dolomitic insert and an axial hole of Ø44 mm; 2 – graphite current distributing disk; 3 – heat insulating dolomitic ring; 4 – heat insulating pyrophyllite ring; 5 – heat insulating dolomitic disk; 6 – steel current connection; 7, 17 – graphite current distributing disk; 8 – heat insulating bushing made of CsCl; 9, 13 – discs made of CsCl; 10 – ring made of CsCl; 11 – alloy, a carbon solvent; 12 – source of carbon, graphite; 14 – cylinder graphite heater; 15 – heat insulating ring made of CsCl–ZrO<sub>2</sub>; 16 – heating element from a mixture of graphite and ZrO<sub>2</sub>; 18 – sensor placement in a cell

The system to control the pressing unit CS-VII was specifically designed to ensure a possibility to regulate over a wide range the heating rate of working cells, to measure temperatures using the thermocouples K-type and S-type. In addition, the manufacturer implemented a system of programmable cooling of hard-alloyed punches by changing a flow of the refrigerant in the circuit of its circulation.

### 5. Selection of source data and design of measuring cells

To build the load characteristics of the pressing unit, we designed two measuring cells, which make it possible to measure pressure in six-punch units using the sensors that represent the pairs of specially selected elements – Co–Fe and Ag–Cu. These measuring cells were used to determine a high quasi-hydrostatic pressure in the range 4–7 hPa and at high temperatures.

Results from studying [16–19] the temperatures of phase transitions in cobalt and iron under the influence of pressure are given in Table 1.

Table 1

Values for temperatures of phase transitions in Co and Fe under the applied pressure based on results from [16–19]

<i>p</i> , hPa	<i>T</i> (α→β–Co), °C	<i>T</i> (α→γ–Fe), °C
0	455	915.7
4	551	663.7
5	570	633.2
6	587	576.1

Table 1 shows there is an offset of temperature values due to pressure.

It is possible to execute resistive pressure control at high temperatures along the lines of polymorphic transformations α→β–Co and α→γ–Fe using the sensor Co–Fe based on the following considerations.

The dependence of transition α→β in cobalt and α→γ in iron on pressure was rather accurately defined in studies [16–19]. Generalization of these data by their polynomial approximation and extrapolation to 7 hPa provided an analytical form of the lines of these transformations:

$$T_{\alpha-\beta}^{Co} = 455 + 28 \times p - 1 \times p^2, \tag{1}$$

$$T_{\alpha-\gamma}^{Fe} = 915,675 + 33,12 \times p - 109,736 \times p^2 + 39,934 \times p^3 - 5,815 \times p^4 + 0,299 \times p^5, \tag{2}$$

where *T* is the temperature in °C; *p* is the pressure in hPa.

The intersection of curves of functions *T*(*p*) for solid-phases transformations for Co<sup>α-β</sup> and Fe<sup>α-γ</sup> (Fig. 3) was determined based on interpolation data at point *p*=5.86 hPa, *T*=585 °C. Until this value, the magnitude for differential difference Δ*T*<sub>*d*</sub><sup>Co-Fe</sup> decreases, followed by an increase for absolute magnitude.

Based on expressions (1) and (2), we have analytically determined the differential difference Δ*T*<sub>*d*</sub> between transformations in cobalt and iron as a function of pressure:

$$\Delta T_d^{Co-Fe} = -460,675 + 5,127 \times p + 108,736 \times p^2 - 39,934 \times p^3 + 5,815 \times p^4 - 0,299 \times p^5, \tag{3}$$

where *T* is the temperature in °C; *p* is the pressure in hPa.

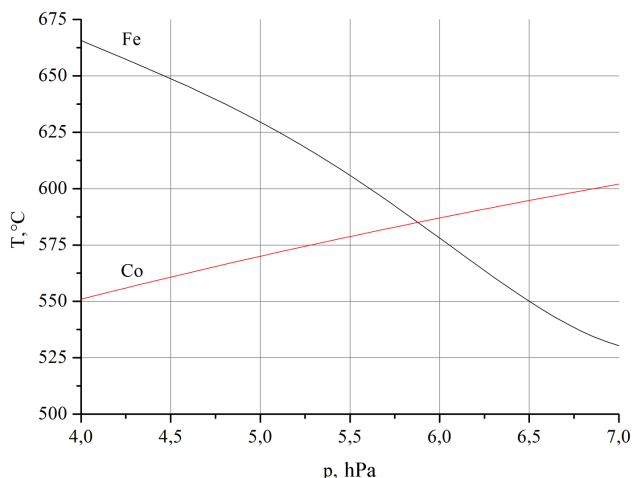

Fig. 3. Temperature dependences of phase transitions in cobalt and iron on pressure, obtained from the generalization and interpolation of experimental data [16–19]

To determine the differential difference  $\Delta T_d^{Ag-Cu}$  as a function of pressure for the melting curves Ag and Cu, we used experimental data from paper [20] (Table 2), which was performed using high-precision equipment of the type piston–cylinder.

Table 2

Values for the melting temperatures of silver and copper under pressure based on results from [20]

$p, \text{ hPa}$	$T_L(\text{Ag}), \text{ }^\circ\text{C}$	$T_L(\text{Cu}), \text{ }^\circ\text{C}$
0	959.0	1,082.8
4	1,184.3	1,231.4
5	1,234.5	1,265.2
6	1,282.4	1,297.6

$$T_L^{Ag} = 958,9 + 61,182 \times p - 1,211 \times p^2, \tag{4}$$

$$T_L^{Cu} = 1082 + 40,179 \times p - 0,707 \times p^2, \tag{5}$$

$$\Delta T_d^{Ag-Cu} = -123,1 + 21,003 \times p - 0,504 \times p^2, \tag{6}$$

where  $T$  is the temperature in  $^\circ\text{C}$ ;  $p$  is the pressure in hPa.

A melting temperature difference between copper and silver in a pressure range 4÷7 hPa is 0.75÷123  $^\circ\text{C}$ , Fig. 4.

Thus, if one uses dependences  $\Delta p=f(T)$  for the sensors  $\text{Co}^{\alpha-\beta}-\text{Fe}^{\alpha-\gamma}$ , the construction of a load characteristic makes it possible to determine the calibration points in the interval  $T=500-670 \text{ }^\circ\text{C}$ . And, for the case of the sensor  $\text{Ag}^L-\text{Cu}^L$ , the application of dependence  $\Delta p=f(T)$  provides a possibility to obtain calibration points in the interval  $T=1,180-1,330 \text{ }^\circ\text{C}$ .

Employing the given formulae (3) and (6) makes it possible to obtain the curves of differential difference between the phase transitions  $\text{Co}^{\alpha-\beta}-\text{Fe}^{\alpha-\gamma}$  and  $\text{Ag}^L-\text{Cu}^L$  due to pressure, which in the range of pressure values 4÷7 hPa take the form shown in Fig. 5.

Equations (1), (2), (4), and (5), as well as dependence charts in Fig. 3–5, were derived by interpolating data from sources [16–20] employing the software OriginPro.

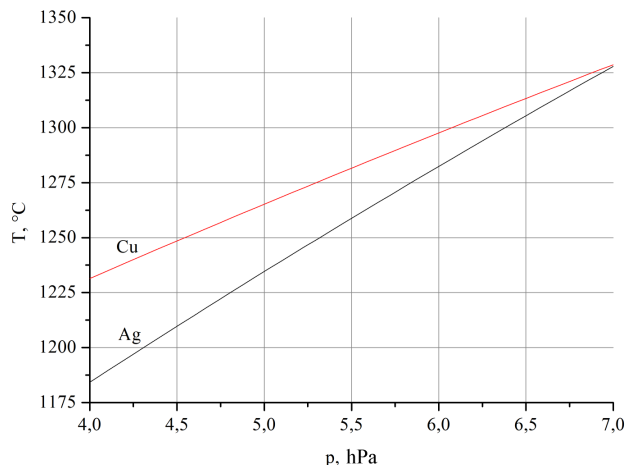

Fig. 4. Dependences of melting temperature on pressure, obtained in paper [20] by the generalization and interpolation of experimental data

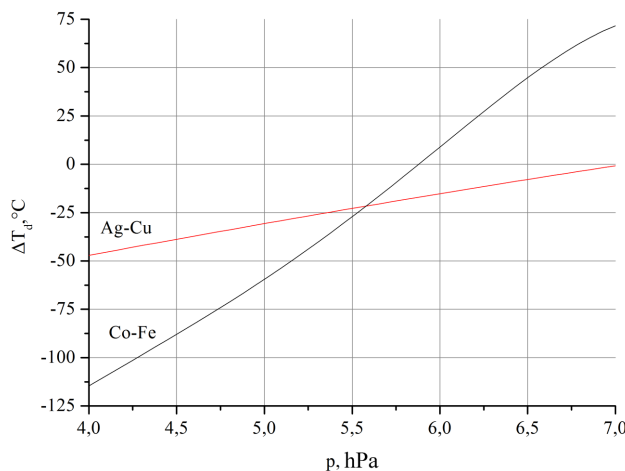

Fig. 5. Dependences of  $\Delta T_d$  on pressure for the pressure sensors Co–Fe and Ag–Cu

All the equations take the following form:

$$T = T_0 + b_1 \times p + b_2 \times p^2 + \dots + b_n \times p^n, \tag{7}$$

where  $T$  is the temperature value in  $^\circ\text{C}$  under pressure,  $p$  is the pressure in hPa,  $T_0$  is the value for temperature under atmospheric pressure,  $b_1, b_2, b_n$  are correction factors for the influence of pressure on temperature [20].

The form of equations (1) to (6) is consistent with the form of equation (7), given in paper [20]; there are also arguments on using a temperature correction of pressure. Table 3 gives selected values from paper [20].

To build a load-carrying characteristic, we have designed measuring cells with the following structures.

*Cell Co–Fe.* The sensor Co–Fe assembly scheme, location of the thermocouple and measuring wires are shown in Fig. 6.

The sensor Co–Fe is the interconnected sections of wire made of iron and cobalt of equal length  $L \sim 60 \text{ mm}$  and 0.3 mm in diameter, located in the same plane at the surface of the disk made of cesium chloride. The ends of the wires are connected to copper contacts, which are insulated from the graphite heater and are connected to two of the six hard-alloyed punches in a high-pressure unit; the heating

circuit of the cell does not pass through them. Inside the circuit, formed in the measuring cell by the Co and Fe wires (Fig. 6), is the thermocouple chromel–alumel (Ø0.3 mm), which is insulated from the sensor wires and the graphite heater. The junction of the thermocouple is at ~1–2 mm from where the wires of cobalt and iron are connected; the ends of the thermocouple are connected to two other hard-alloyed punches of the six-punch unit, which are also not used for the electrical heating of the cell. Four punches that are used for measuring electrical resistivity of the sensor Co–Fe and to register readings from the thermocouple are electrically isolated from all other metallic parts of the pressing unit.

Table 3

Values for the melting temperatures of gold, silver, and copper under pressure with and without a correction [20]

$p$ , hPa	Au		Ag		Cu	
	Cor-rected	Non-cor-rected	Cor-rected	Non-cor-rected	Cor-rected	Non-cor-rected
0	1,062.0	1,062.0	959.0	959	1,082.8	1,082.8
0.5	1,089.5	1,090.9	988.0	989.3	1,100.0	1,101.4
2.0	1,173.1	1,178.0	1,072.0	1,077.0	1,153.0	1,158.5
3.5	1,254.8	1,262.7	1,150.0	1,158.0	1,206.5	1,214.5
5.5	1,352.1	1,362.9	1,248.0	1,259.2	1,271.5	1,282.5
6.5	1,392.4	1,404.2	1,292.0	1,304.4	1,298.0	1,310.0

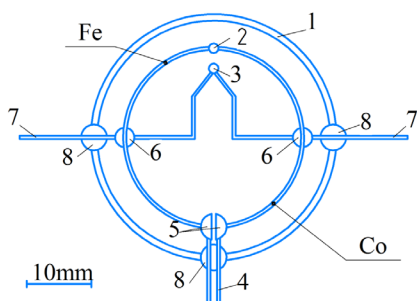

Fig. 6. Schematic of a pressure measuring cell using the sensor Co–Fe (diametrical section of the heater): 1 – graphite heater; 2 – pressure contact of wires Co and Fe; 3 – junction of the thermocouple XA; 4 – connections of the sensor Co–Fe (electrotechnical copper to enable a contact with the pressing unit’s punches); 5 – molybdenum contact; 6 – thermocouple wire insulation from the sensor’s wires (cesium chloride); 7 – connections of the thermocouple to enable a contact with punches; 8 – electrical insulation of the thermocouple’s wires from a graphite heater

A principal electric diagram of the sensor Co–Fe is shown in Fig. 7; the wires of Co and Fe are connected in series and are connected to the punches of the pressing unit through molybdenum contacts and copper wires.

The differential pressure sensor Co–Fe (Fig. 6, 7) is designed to register the structural transformations  $\alpha$ – $\beta$  in cobalt and  $\alpha$ – $\gamma$  in iron by an electrical resistivity measurement method. The serial connection of Co and Fe wires with the output of the measuring circuit through punches makes it possible, by using a two-end method [21], to determine the surges in resistance during transformation of crystal structures  $\text{Co}^{\alpha-\beta}$  (FCC→HCP) and  $\text{Fe}^{\alpha-\gamma}$  (BCC→FCC).

Cell Ag–Cu. Schematic of the melting sensor Ag–Cu is shown in Fig. 8.

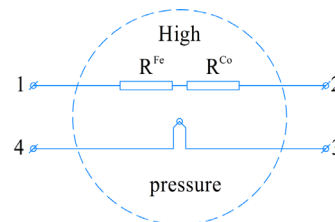

Fig. 7. A principal electric diagram of connecting the wires of iron and cobalt for the sensor Co–Fe: 1, 2 – connection of the sensor Co–Fe to punches 1 and 2 of the pressing unit; 3, 4 – connection of the thermocouple sensor to punches 3 and 4 of the pressing unit

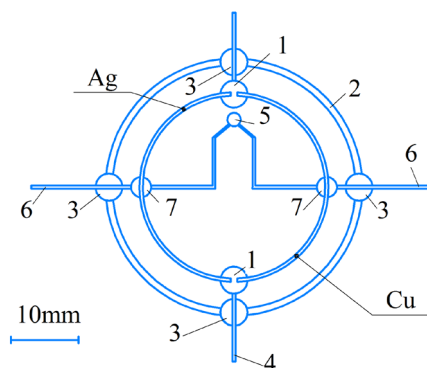

Fig. 8. Schematic of a pressure measuring cell by the sensor Ag–Cu (diametrical section of the heater): 1 – graphite contact of the sensor Ag–Cu and output to the punches; 2 – graphite heater; 3 – electrical insulation (cesium chloride) of wires at places of output through the graphite heater; 4 – connections of the sensor Ag–Cu via electrotechnical copper and a graphite contact; 5 – junction of the thermocouple S-type; 6 – outputs of the thermocouple; 7 – thermocouple wire insulation from the sensor wires (cesium chloride)

The sensor Ag–Cu is the wires of equal length ( $L=60$  mm, Ø0.3 mm), connected in parallel using a graphite contact with outputs made from electrotechnical copper. The latter connect the sensor to two punches, not intended for the resistive heating of a cell in the six-punch pressing unit. The silver and copper wires, as well as graphite contacts and copper outputs from the cell, are insulated from the graphite heater by cesium chloride. The choice of graphite as a material to enable a contact with copper and silver is predetermined by the extremely low solubility of carbon in these metals at temperatures up to metal melting.

The junction of the thermocouple of S-type, made from wires of platinum and the alloy platinum rhodium (PtRh10 %), is at a distance of ~2 mm from graphite contact 1 (Fig. 8). The intersections between the sensor wire and the thermocouple are separated by electrical insulation made of cesium chloride.

A principal electric diagram of the sensor Ag–Cu is shown in Fig. 9; the wires Ag and Cu are connected in parallel and are connected to the punches of the pressing unit through the molybdenum transition elements to copper contacts made from electrotechnical copper.

Fig. 9 shows that the constituent elements  $R^{\text{Ag}}$  and  $R^{\text{Cu}}$  are connected in parallel in the electrical connection circuit; their total resistance  $R$  is determined from:

$$\frac{1}{R} = \frac{1}{R^{Ag}} + \frac{1}{R^{Cu}} \tag{8}$$

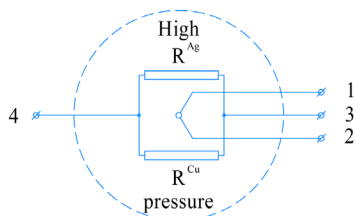

Fig. 9. A principal electric diagram of connecting the wires of copper and silver for the melting sensor: 1, 2 – connection of the thermocouple sensor to punches 1 and 2 in the pressing unit; 3, 4 – connecting the melting sensor Ag–Cu to punches 3 and 4 in the pressing unit

The principle of operation of the melting sensor Ag–Cu is that at the time of copper and silver melting the measuring chain registers a contact break through  $R^{Ag}$  and  $R^{Cu}$  (Fig. 7). A break in the measuring circuit in this case is due to patterns in the performance of conductors under quasi-hydrostatic conditions with such a ratio of their linear dimensions that the length is significantly larger than the diameter. Under these conditions, given the existence of pressure gradients, the liquid phase contracts to drops, there is the discontinuity of wires Ag and Cu, and, as a consequence, the break of the electrical circuit.

### 6. Building a load characteristic based on signals from the high-pressure sensors Co–Fe and Ag–Cu

When using the resistive pressure sensors Co–Fe and Ag–Cu, we determined the temperatures of phase transitions, which made it possible to determine the pressure generated inside the cell of HPU. Signals from the sensor Co–Fe are registered by the device according to the measurement scheme in Fig. 8; the measured change in voltage at transitions  $\alpha \rightarrow \beta$ -Co and  $\alpha \rightarrow \gamma$ -Fe at the sensor's output is approximately  $\sim 0.3$ – $0.5$  and  $\sim 0.2$ – $0.3$  mV, respectively.

The curve that records the Co–Fe sensor signal clearly registers surges in electric resistance with an increase in pressure and temperature (Fig. 10).

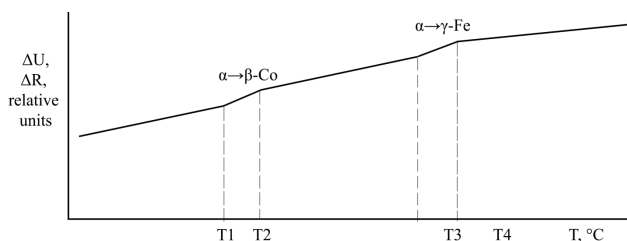

Fig. 10. A general form of change in a signal from the pressure sensor Co–Fe, the loading speed of plungers is 0.035 MN/sec, heating rate is  $\sim 10$ – $12$  deg/s,  $T_1$ – $T_2$  and  $T_3$ – $T_4$  are the temperatures of the onset and end of phase transitions in cobalt and iron, respectively

The difference in intervals  $T_2$ – $T_1$  and  $T_4$ – $T_3$  typically does not exceed 2–3 °C.

For the constituent elements of the melting sensor Ag–Cu, the first to melt is silver  $T_L^{p=6.5 \text{ hPa}} = 1305,7$  °C, the result being the total magnitude of electrical resistance,

determined by a two-end method at a melting point in time, increases in a jump-like manner. The values for temperature according to the readings from a thermocouple correspond to a surge in resistance, registered by the measuring circuit, the first value is required for determining the difference  $\Delta T$ . The second value is the reading from a thermocouple at copper melting  $T_L^{p=6.5 \text{ hPa}} = 1313,5$  °C at a complete break of the measuring circuit for the sensor Ag–Cu (Fig. 8, 9).

A general pattern of change in the resistance of the sensor Ag–Cu is shown in Fig. 11.

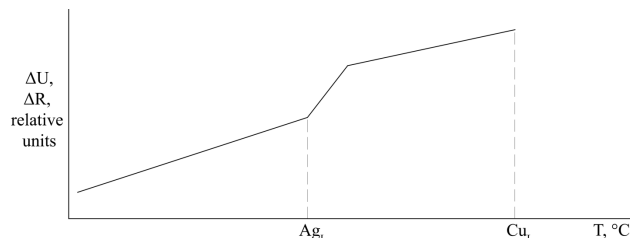

Fig. 11. General pattern of change in the signal from the pressure sensor Ag–Cu, the loading speed of plungers is 0.035 MN/sec, heating rate is  $\sim 10$ – $12$  deg/sec

A pressure sensor signal and the thermocouple sensor readings are recorded by measuring devices with the following accuracy: a change in voltage on the sensor Ag–Cu –  $\pm 2$   $\mu\text{V}$ , thermo-EMF of the thermocouple S-type –  $\pm 5 \times 10^{-4}$  mV.

Thus, the differential method of pressure measurement could be applied for measuring high quasi-hydrostatic pressures in the range of 4–7 hPa in a cell of the six-punch unit at elevated temperatures.

The data obtained were used to build a load characteristic, which takes the form shown in Fig. 12.

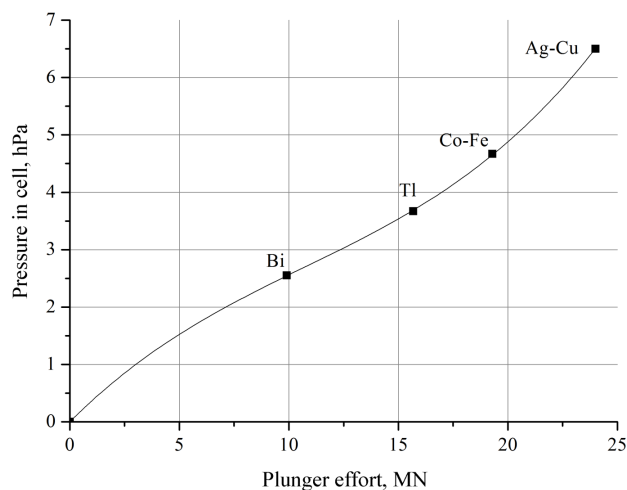

Fig. 12. Load characteristic of the pressing unit CS-VII when using the fixed points of phase transitions in bismuth and thallium at room temperature and differential temperature differences  $\text{Co}^{\alpha-\beta}$ - $\text{Fe}^{\alpha-\gamma}$  and  $\text{Ag}^I$ - $\text{Cu}^I$  (Fig. 5) when  $T = 563.9$ – $642.7$  °C –  $p = 4.67$  hPa and at  $T = 1,305.7$ – $1,313.5$  °C –  $p = 6.5$  hPa, respectively

When determining a load characteristic, each calibration point (Fig. 12) corresponds to a separate cycle of loading a high-pressure calibration cell. We determined pressure at room temperature based on phase transformations in Bi (I–II)  $2.55 \pm 0.01$  hPa and Tl (II–III),  $3.67 \pm 0.03$  hPa, using resistometry by a two-end method. The diameter and length

of the resistance sensor were 0.3 and 2 mm respectively, and the loading speed of plungers was maintained at 0.06–0.061 MN/sec. Registration of pressure during phase transitions was acquired at the onset of a resistance surge in a phase transition.

The heating to increase the temperature of the container and the calibration cell was enabled when reaching an effort of 17.1 MN in each compressing plunger. Next, the loading of a pressing unit to the resulting effort of compression was performed at speed 0.035 MN/sec under a heating rate of 10–12 deg/sec.

### 7. Discussion of results of applying a differential method for determining pressure by the sensors Co–Fe and Ag–Cu

The employed procedure for determining pressure by a differential technique using resistometry at high temperatures enables the construction of load characteristics for six-punch pressing units. Such HPUs have been recently widely used both to obtain the diamond grinding powders and for growing the structurally-perfect single crystals of diamond. Although such pressing units demonstrate high performance and are promising for the development of new technologies and materials, the biggest challenge to use them is the impossibility of determining the magnitudes for pressure in growth cells. Control over pressure magnitudes depending on the materials used for the manufacture of containers and pushing punches, configuration of the working compression elements, is also challenging. The proposed method for constructing load characteristics for six-punch high pressure units makes it possible to easily solve a given problem.

Thus, the results of our research could be used in the field of physics of high pressures. The current work might also prove useful in the design of new, and obtaining already known, superhard materials. The application of the proposed procedure would significantly enhance the accuracy of determining pressure in the cells of HPU, which in turn would improve the qualitative indicators for materials obtained.

The main advantage of using the differential method is that it makes it possible to take into consideration the impact of high temperatures on the process of creating pressure in the cells of HPU. Determining a temperature difference in phase transitions in reference materials under the influence of high pressure makes it possible to perform measurements with a rather low error. This is predetermined by that all the

components of parasitic EMF are self-eliminated owing to the differential scheme. In this regard, the measurement accuracy is limited only by the class of precision of measuring instruments. Consequently, the benefit of a given procedure is the fact that the resistive sensors Co–Fe and Ag–Cu do not need calibration. In this case, the above merits make it possible to determine pressures in the units' cells with a rather complex configuration of pushing parts, as well as in machines where direct connection of reference sensors is impossible due to their structural features.

However, there are certain limitations to the implementation of a given method. The most significant disadvantage is the high cost of pure materials. In addition, there are specific difficulties associated with the manufacturing of a wire with the desired geometrical dimensions, at in most cases the raw materials of high purity (99.99 %) are available in the form of ingots or a powder. In addition, mounting the sensors in a high-pressure cell, as well as connecting them to the measuring system of instruments, is a rather tedious and troublesome task.

Given the above shortcomings, the outlined procedure requires certain refinement in the future. There is a need for additional research to ensure the ease of fabrication of pressure sensors, to select cheaper pairs of reference materials.

### 8. Conclusions

1. The application of Co–Fe sensors of the proposed design makes it possible to determine a value for pressure at temperatures in the range of 500–700 °C based on a difference between the points of phase transitions in reference materials. For a six-punch HPU, we have determined a high pressure value by using a resistive sensor at  $T=563.9\text{--}642.7$  °C, which amounted to 4.67 hPa. Using a sensor manufactured from the materials Ag–Cu allows the determination of values for pressures at high temperatures 1,300–1,400 °C. For a six-punch HPU, we have determined a high pressure value at  $T=1,305.7\text{--}1,313.5$  °C, which amounted to 6.5 hPa.

2. The application of the devised procedure for determining pressures using resistometry has allowed us to build a load characteristic for the six-punch high-pressure unit of model CS-VII at high temperatures generated inside a high-pressure cell. Using the outlined procedure makes it possible to measure pressures in the cells of HPU with an accuracy that is limited only by the precision class of instrumentation.

### References

1. Novikov N. V. Sinteticheskie sverhtverdye materialy. Vol. 1. Sintez sverhtverdyh materialov. Kyiv: Naukova dumka, 1986. 280 p.
2. The deformation-DIA: A new apparatus for high temperature triaxial deformation to pressures up to 15 GPa / Wang Y., Durham W. B., Getting I. C., Weidner D. J. // Review of Scientific Instruments. 2003. Vol. 74, Issue 6. P. 3002–3011. doi: <https://doi.org/10.1063/1.1570948>
3. Pressure generation to 25 GPa using a cubic anvil apparatus with a multi-anvil 6-6 assembly / Kawazoe T., Nishiyama N., Nishihara Y., Irifune T. // High Pressure Research. 2010. Vol. 30, Issue 1. P. 167–174. doi: <https://doi.org/10.1080/08957950903503912>
4. Tonkov E. Yu. Fazovyie diagrammy elementov pri vysokom davlenii. Moscow: Nauka, Glavnaya redaktsiya fiziko-matematicheskoy literatury, 1979. 192 p.
5. Liebermann R. C. Multi-anvil, high pressure apparatus: a half-century of development and progress // High Pressure Research. 2011. Vol. 31, Issue 4. P. 493–532. doi: <https://doi.org/10.1080/08957959.2011.618698>
6. Stupnikov V. A., Bulychev B. M. Vysokie davleniya v himii. Almaz ialmazopodobnye materialy, tekhnicheskie i sinteticheskie aspekty. Moscow: MGU im. M. V. Lomonosova, 2012. 112 p.

7. Bogdanov S. P. Rol' razmera kristallitov grafitopodobnogo nitrída bora pri nukleatsii kubicheskogo nitrída bora // Fizika i himiya stekla. 2008. Vol. 34, Issue 2. P. 274–280.
8. Cubic Press Machine Catalog. Guilin Guiye Machinery Co., Ltd. URL: <https://glguiye.en.made-in-china.com/Product-Catalogs/>
9. Metodika differentsial'nogo termicheskogo analiza pri davleniyah do 8GPa. Kyiv, 1989. 16 p.
10. Getting I. C., Kennedy G. C. Effect of Pressure on the emf of Chromel-Alumel and Platinum-Platinum 10% Rhodium Thermocouples // Journal of Applied Physics. 1970. Vol. 41, Issue 11. P. 4552–4562. doi: <https://doi.org/10.1063/1.1658495>
11. Hanneman R. E., Strong H. M. Pressure Dependence of the emf of Thermocouples // Journal of Applied Physics. 1966. Vol. 37, Issue 2. P. 612–614. doi: <https://doi.org/10.1063/1.1708224>
12. Sposib kalibruvannia vysokoho tysku do 6,5Hpa v konteinerakh iz kvazihidrostatychnymy peredavalnymy seredovyshchamy shestypuansonnnykh kubichnykh presiv: Pat. No. 132612 UA. MPK B01J 3/06. No. u201806114; declared: 01.06.2018; published: 11.03.2019, Bul. No. 5.
13. Sonin V. M., Sokol A. G. Razrabotka DTA na monogopuansonnom aparate vysokogo davleniya // Eksperimental'nye issledovaniya kristallizatsii almaza v metallicheskih sistemah. Novosibirsk, 1993. P. 78–82.
14. Izmerenie vysokih kvazigidrostaticheskikh davleniy do 7 GPa differentsial'nym metodom pri temperaturah do 1400 °C / Novikov N. V., Ivahenko C. A., Chipenko G. V., Belousov I. S. // Dokl. AN SSSR. 1990. Vol. 311, Issue 6. P. 1368–1371.
15. Izmerenie davleniya differentsial'nym metodom po krivym plavleniya svintsá i tsinka. Obrabotka materialov pri vysokom davlenii / Ivahnenko S. I., Chipenko G. V., Belouov I. S., Zanevskiy O. A. // Sbornik nauchnyh trudov AN USSR, IPM AN USSR. 1987.
16. Claussen W. F. High Pressure Measurement / A. A. Giardini, E. C. Lloyd (Eds.). Washington: Butterworths, 1963. P. 125.
17. Kenedi D., N'yuton R. V. Tverdye tela pod vysokim davleniem / A. P. Vinogradov (Ed.). Moscow: Mir, 1966. 167 p.
18. Kaufman L., Clougherty E. V., Weiss R. J. The lattice stability of metals – III. Iron // Acta Metallurgica. 1963. Vol. 11, Issue 5. P. 323–335. doi: [https://doi.org/10.1016/0001-6160\(63\)90157-3](https://doi.org/10.1016/0001-6160(63)90157-3)
19. Bundy F. P., Strong H. M. Behavior of Metals at High Temperatures and Pressures // Solid State Physics. 1962. P. 81–146. doi: [https://doi.org/10.1016/s0081-1947\(08\)60456-7](https://doi.org/10.1016/s0081-1947(08)60456-7)
20. Akella J., Kennedy G. C. Melting of gold, silver, and copper-proposal for a new high-pressure calibration scale // Journal of Geophysical Research. 1971. Vol. 76, Issue 20. P. 4969–4977. doi: <https://doi.org/10.1029/jb076i020p04969>
21. Batavin V. V., Kontsevoy Yu. A., Fedorovich Yu. V. Izmerenie parametrov poluprovodnikovyyh materialov i struktur. Moscow: Radio i svyaz', 1985. 264 p.