

Представлено дані міжлабораторних порівнянь результатів калібрування генераторів сигналів в трьох точках калібрування. Здійснено вибір методології оброблення результатів міжлабораторних порівнянь результатів з урахуванням довготривалого дрейфу зразка порівняння. Проведено модернізацію і дослідження зразка порівняння для міжлабораторних порівнянь результатів з калібрування генераторів сигналів. Визначені приписані значення для трьох точок калібрування та їх розширені невизначеності. Отримано вирази для апроксимації довготривалого дрейфу зразка порівняння і складено бюджети невизначеностей для всіх його приписаних значень зразка порівняння на частотах 130 МГц, 168 МГц і 223 МГц.

Визначені міжлабораторні відхилення отриманих лабораторіями результатів та оцінено узгодженість отриманих ними даних за допомогою показників E_p та z . Це характеризує достовірність та точність результатів вимірювань лабораторій, а також є важливим для підтвердження технічної компетентності. Представлені результати міжлабораторних порівнянь результатів калібрування генераторів сигналів показують, що всі лабораторії-учасниці задовольняють вимогам щодо показника E_p -індексу. В той же час дві лабораторії з десяти потребують як суттєвих, так і певних заходів корегування, так як не задовольняють вимогам щодо показника z .

Встановлено, що показник E_p не завжди є самодостатнім. Він в більшій мірі характеризує лише достовірність результатів вимірювань лабораторій. Для цього більш інформативним є показник z , який дає кращу інформативність щодо точності вимірювань в лабораторіях, тобто наближеності результатів вимірювань до істинного значення

Ключові слова: міжлабораторні порівняння, калібрувальна лабораторія, невизначеність вимірювань, генератор сигналів, зразок порівняння

UDC 389:14:621.317:354

DOI: 10.15587/1729-4061.2019.166504

INTERLABORATORY COMPARISONS OF THE CALIBRATION RESULTS OF SIGNAL GENERATOR

O. Velychko

Doctor of Technical Sciences, Professor, Director*

S. Shevkun

PhD, Head of Department**

O. Mescheriak

Head of Research Laboratory Measurements of Time and Frequency**

T. Gordiyenko

Doctor of Technical Sciences, Professor, Head of Department

Department of Standardization, Conformity Assessment and Educational Measurements

Odessa State Academy

of Technical Regulation and Quality

Kovalska str., 15, Odessa, Ukraine, 65020

E-mail: t_gord@hotmail.com

S. Kursin

PhD, Head of Laboratory*

*Scientific and Production Institute of Electromagnetic Measurements***

Department of State Standards of Electromagnetic Quantity, Time and Frequency*

***State Enterprise «All-Ukrainian State Scientific and Production Centre for Standardization,

Metrology, Certification and Protection of Consumer», (SE «Ukrmetrteststandard»)

Metrolohichna str., 4, Kyiv, Ukraine, 03143

1. Introduction

The role of measurement and metrology in scientific research, testing of measuring instruments (MI) and other diversified products is constantly increasing. Requirements for the accuracy and reliability of the results of measurements and tests are significantly increased and their ranges are expanded. The achievement of the competitiveness of national commodity producers in the world market is impossible without taking into account modern metrological norms and rules, rules of conformity assessment of products, set forth in modern regulatory legal acts and normative documents. At the present stage of the development of society, the mutual international recognition of the results of measurements carried out in different countries becomes critical for the removal of technical barriers to trade and, as a consequence, for participation in multilateral trade agreements.

Metrological traceability is extremely important for applied metrology [1]. It allows comparing the accuracy of measurements in accordance with the standardized procedure for estimating measurement uncertainty [2]. For the implementation of metrological traceability in accordance with [3], an important role is played by calibration laboratories (CL). Interlaboratory comparisons (IC) are one form of experimental verification of the activities of accredited laboratories. IC must meet the requirements of national standards DSTU ISO/IEC 17025 [4] and DSTU EN ISO/IEC 17043 [5], which are harmonized with the relevant international and European standards. DSTU ISO/IEC 17025 [4] regulates the provisions regarding the technical competence of accredited laboratories and traceability of measurements. The purpose of IC is to establish interlaboratory differences among their participants [6]. Successful results of IC are confirmation of the laboratory competence in carrying out

certain types of measurements by a particular specialist on specific equipment [7].

The use of appropriate methods for processing results is important for obtaining reliable data about IC of accredited laboratories. These methods are based on various data processing algorithms in accordance with the requirements of international and regional guidelines and standards [8, 9]. However, in addition to the data processing method, other factors that may influence IC should be taken into account. In particular, unsatisfactory results of IC may be related to: a large time drift of the comparison sample (CS); deviation from the normal state of the laboratory's competence; problems with the laboratory equipment; insufficient competence of the specialist who worked with it, etc. [7].

IC are conducted by competent coordinators of such tests, reference laboratories (RL). The results of participation in a particular IC are assessed using the criteria set by the IC coordinators. The IC coordinator: sets the assigned value of the measured quantity; determines the uncertainty of the assigned value; carries out the necessary processing of the results obtained; establishes interlaboratory deviations and formulates conclusions for all participating laboratories. The choice of a particular method for processing the IC results depends on the type of the studied comparison sample, the characteristics of the tests or calibrations, and the number of IC participating laboratories. The stability of the CS is a qualitative characteristic that reflects the immutability of its metrological characteristics (MC) over time. Instability of the CS means a change in the measurement result at a given value of the environmental characteristic, which includes drift and fluctuations as a result of the change of a calibration function during the period of absence of constant maintenance. Moreover, drift and fluctuations over time determine, respectively, the monotonous and stochastic changes in the output signal.

The urgency of the study is due to the need for IC to ensure recognition of the results obtained both at the national and international levels. Publications devoted to the organization of IC, methods for processing the obtained data and increasing the reliability are of considerable interest. This question is extremely relevant in view of the lack of conducted IC for calibrating signal generators.

2. Literature review and problem statement

A thorough analysis of normative documents concerning the processing of data obtained in IC, based on statistical methods, is made in [6–9]. In particular, a procedure for linking the results of IC of national standards and IC at the national level, using the example of AC/DC voltage standards was proposed in [6]. This will improve the identification of interlaboratory differences and the level of certainty for statements of equivalency of participating laboratories. In [7], a universal algorithm for processing the primary data of IC, obtained during calibration of a time meter, which allows the RL to take into account all the features of reporting on conducted IC was proposed. [8] analyzed the international and regional guidelines and standards on which the methods for processing of IC results are based. In [9], the application of a data processing method that has a minimal number of restrictions and allows for reliable results was justified. It should be noted that the available scientific publications on the topic of the study cover the peculiarities of conducting IC for analytical (physical and

chemical) test laboratories or the issues of the specificity of IC for CL for specific types of measurements [6, 7].

In work [10], two methods of IC data processing are considered, but they are based on the application of the same procedure. In the works [11–13], the algorithms and results of IC for assessing the measurement capabilities of laboratories and obtaining highly accurate and precise data are given. However, these works do not take into account such an important element as the time and temperature drifts of CS, which significantly affects the results of the test.

Some works [14–19] are devoted to the study of the features of IC. In particular, [14] considers approaches to improving the methods for measuring and estimating the uncertainty of the laboratories participating in IC for active power measurement, and [15] evaluates the IC data of laboratories with further calculation of the uncertainty of measurement results. The data of each participating laboratory was evaluated using a criterion such as the *z*-index. However, the paper [14] does not substantiate the advantage of choosing the *z*-index criterion in comparison with other statistical performance criteria. In [16–19], approaches to establishing a long-term drift of the comparison standard for international comparisons of national standards was presented. This approach can also be applied to IC, determining the long-term CS drift. In addition, it is also advisable to define a short-term CS drift to establish an appropriate component of the general uncertainty for the calibration of the CS.

The studies have shown the urgent need to develop and improve available processing techniques of IC data taking into account the CS drift. This will contribute to enhancing the accuracy of the CS study to reduce the uncertainty of measurements conducted by IC participating laboratories.

3. The aim and objectives of the study

The aim of the study is to improve the available methods of IC data processing taking into account the time and temperature drift of the CS. It is necessary during processing of data received from participating laboratories to take into account the provision of metrological traceability of different levels in relation to the CS used, minimization of the uncertainty of the assigned value when conducting IC.

To achieve the aim, the following objectives were set:

- to create a special CS to participate in IC for calibrating signal generators;
- to investigate the CS for IC to calibrate signal generators, determine the assigned value and expanded uncertainty for IC;
- to evaluate the results of the CS study by IC participating laboratories for calibrating signal generators;
- to evaluate the consistency of the obtained IC results on the calibration of signal generators.

4. Materials and methods of researching approaches to estimating IC for calibrating the signal generator

Calculation of the interlaboratory deviation of measurement results and consistency verification of the data are carried out during processing the primary data from IC participating laboratories. To verify the consistency of the data, a comparative analysis of the relevant statistical performance criteria is made and the most effective one for use in data processing is chosen.

Interlaboratory deviations of measurement results of IC participating laboratories are determined by:

$$D_{labj} = x_{labj} - X_{AV}, \tag{1}$$

where x_{labj} – frequency value measured by the IC participating laboratory; X_{AV} – assigned frequency value calculated by the RL.

An evaluation of the results of each IC participant is traditionally carried out using a modified statistical performance criterion by the E_n indicator, which is defined by the expression:

$$E_n = \frac{D_{lab}}{\sqrt{U^2(x_{lab}) - U^2(X_{AV})}}, \tag{2}$$

where $U(x_{lab})$ – expanded uncertainty of measurements in determining the frequency values by the IC participating laboratory; $U(X_{AV})$ – expanded uncertainty of measurements in determining the assigned value frequency by the RL.

At the same time, if:

- $|E_n| \leq 1.0$ – the result does not require correction or response measures;
- $|E_n| > 1.0$ – the result requires correction or response measures.

The consistency assessment of the data of IC participating laboratories can also be carried out using the statistical performance criterion by the z indicator which is determined by:

$$z = (D_{labj} - x^*) / s^*, \tag{3}$$

where D_{labj} – deviation of laboratory measurement results; x^* and s^* – correspondingly robust mean value and robust standard deviation calculated in accordance with the algorithm A of DSTU ISO 13528 [20].

At the same time, if:

- $|z| \leq 2.0$ – the result does not require correction or response measures;
- $2.0 < |z| < 3.0$ – the result requires some correction or response measures;
- $|z| > 3.0$ – the result needs substantial correction or response measures.

To calculate the robust mean x^* and the robust standard deviation s^* , their initial values x_{init}^* and s_{init}^* for $i=1, 2, \dots, p$ (where p – the number of IC participants) are calculated initially by the expressions:

$$x_{init}^* = \text{median } x_i, \tag{4}$$

$$s_{init}^* = 1.483 \text{ median } |x_i - x_{init}^*|, \tag{5}$$

where x_i – deviation of frequency measurement results of IC participants from the assigned frequency value calculated by the reference laboratory.

Then the value of the correlated robust mean $x_{cor i}^*$ for each x_i ($i=1, 2, \dots, p$) is calculated by the expression:

$$x_{cor i}^* = \begin{cases} x_{cor i}^* - \delta, & \text{if } x_i < x_{init}^* - \delta, \\ x_{cor i}^* + \delta, & \text{if } x_i > x_{init}^* + \delta, \\ x_{cor i}^* & \text{in other cases,} \end{cases} \tag{6}$$

where δ – clarified value s_{init}^* , calculated by:

$$\delta = 1.5s_{init}^*. \tag{7}$$

The final values x^* and s^* are calculated by:

$$x^* = \sum_{i=1}^p \left(\frac{x_{cor i}^*}{p} \right), \tag{8}$$

$$s^* = 1.134 \sqrt{\sum_{i=1}^p \frac{(x_{cor i}^* - \bar{x}_{cor}^*)^2}{p-1}}, \tag{9}$$

where \bar{x}_{cor}^* – the average value of all $x_{cor i}^*$, $i=1, 2, \dots, p$.

If the data are inconsistent, an analysis is made with a view to their rejection or further concordance by clarifying the applied indicators.

5. Results of the interlaboratory comparison of signal generator calibration

5.1. Creating a comparison sample for interlaboratory comparisons of results

The RL (Ukrmetrteststandart, Kyiv, Ukraine) upgraded the BPSG6 OEM signal generator from Aaronia AG (Germany) for the technical support of IC by the type of time and frequency measurement. The purpose of the modernization was to create a compact CS for IC based on a panel device. The CS is a stable trinomial measure of high frequency with autonomous power and resistance to external mechanical and climatic factors.

The block diagram of the CS for IC is shown in Fig. 1.

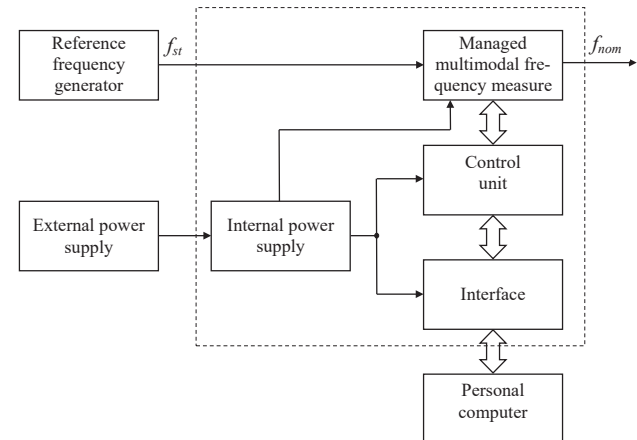

Fig. 1. Block diagram of the CS for IC

A special program file was created to set necessary generating regimes with a sequential change of the nominal frequency 130 MHz→168 MHz→223 MHz (every hour). This program file from a personal computer (with Aaronia software installed) via the USB interface is written to the internal memory of the controlled multi-valued frequency measure – upgraded BPSG6 OEM signal generator. This generator is powered by an external power supply or an internal rechargeable backup power supply with the controller. The controller allows charging the battery, both from the external power supply and from the USB interface.

Basic technical characteristics (TC) of the BPSG6 OEM signal generator, regarding its use as a CS for IC:

- frequency range from 130 MHz to 223 MHz;
- output signal level – 1.5 V;
- interface – USB;
- power – 12 V from the power supply or USB.

During upgrading the BPSG6 OEM signal generator, the following changes were made:

- a new ergonomic compact body of aluminum alloy, resistant to external mechanical factors under the conditions of IC was made;
- all the elements of switching and control required for IC were placed on the front panel;
- connectors and interfaces – USB required for IC were placed on the back panel;
- the external switching power supply was replaced with the transformer one to reduce the effect of high-frequency noise during the study by IC participants;
- a special program control file for the generator was created to specify the required frequency generation modes with successive frequency changes 130 MHz→168 MHz→223 MHz.

The standard SMA connector was replaced with the output of the measuring signal with the type N connector for the possibility of using the BPSG6 OEM signal generator in IC as a CS. The use of the standard SMA connector complicated its connection in many IC laboratories that use the N connector for high-frequency measurements. In this case, the use of various adapters introduces an additional component of the overall uncertainty to the measurement result. The generator also uses the BNC connector instead of the SMA connector to input the synchronization signal from an external reference frequency source, which allowed IC laboratories to implement their own CS study procedure.

5. 2. Results of researching a comparison sample for IC

During 2018, the RL organized and conducted IC for calibrating the upgraded BPSG6 OEM signal generator in accordance with the requirements of DSTU ISO/IEC 17025 [4], DSTU EN ISO/IEC 17043 [5] and DSTU ISO 13528 [20]. The main purpose of IC was to conduct a qualification check of the CL based on the type of time and frequency measurement. The qualification check program was implemented in accordance with the requirements of DSTU EN ISO/IEC 17043 [5].

11 laboratories that conducted calibration according to their own calibration techniques participated in IC with the radial scheme. The RL prepared a transported CS, defined its value before, during, and after comparisons, determined the CS drift and relevant uncertainties.

Three calibration frequencies were selected as calibration points: 130 MHz, 168 MHz and 223 MHz.

Frequency values were programmed by the RL and were not subject to changes throughout the IC.

The CS signals of a given frequency were fed through the same CS output permanently after switching it on, replacing one another every hour in the order of 130 MHz, 168 MHz and 223 MHz.

Calibration was carried out under normal conditions in accordance with the requirements: air temperature (23±3) °C; relative humidity (50±20) %.

Similar approaches to the establishment of long-term CS drift, which are presented in [16–19], can also be used for IC. So, this task was entrusted to the IC RL.

Graphs of the long-term drift of frequencies received by the RL are shown in Fig. 2–4.

The values of the frequency difference Δf (Fig. 2–4) on the vertical axis are given and calculated by:

$$\Delta f = f_{AV} - f_{nom}, \tag{10}$$

where f_{AV} – frequency value (assigned value) measured by the RL; f_{nom} – nominal frequency value (calibration point).

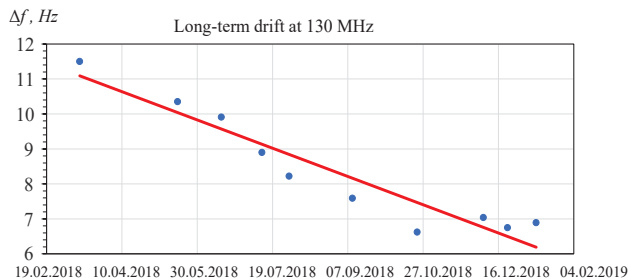

Fig. 2. Long-term drift of assigned value for 130 MHz frequency

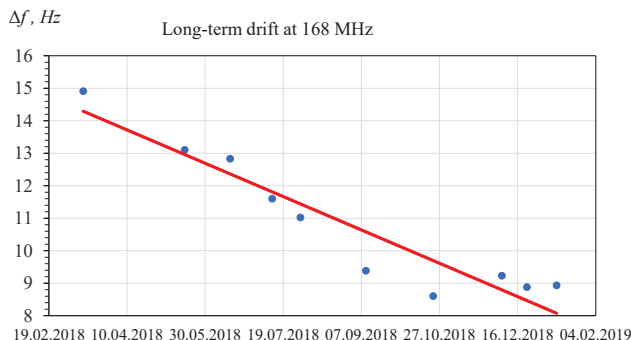

Fig. 3. Long-term drift of assigned value for 168 MHz frequency

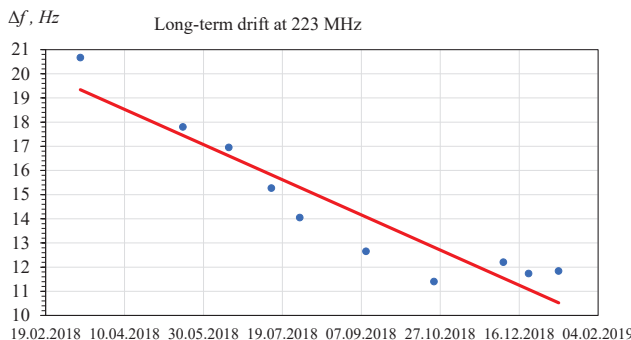

Fig. 4. Long-term drift of assigned value for 223 MHz frequency

To calculate the assigned frequency, the RL performed 10 calibrations during IC (after each IC participant). The expressions for the drift of the assigned CS value for all three calibration points are defined. The assigned frequency values for the date of calibration of each participant are approximated.

The expressions obtained by the RL for long-term drift approximation are:

$$y_1 = -0.0162x + 709.15, \tag{11}$$

$$y_2 = -0.0205x + 900.39, \tag{12}$$

$$y_3 = -0.0291x + 1276.5, \tag{13}$$

where y_1, y_2, y_3 – the corresponding approximated assigned values of 130 MHz, 168 MHz and 223 MHz; x – the natural number corresponding to the date of approximation. For the first participant $x=43.225$, which corresponds to 05.05.2018 (beginning of IC). Every next day adds one to the number x .

Frequency drift values are calculated by:

$$f_{dr} = f_{max} - f_{min}, \tag{14}$$

where f_{max} and f_{min} – respectively, the maximum and minimum frequency values calculated by the RL for the entire duration of IC.

Calculated by the expression (14), the frequency drift values for the corresponding calibration point are: 130 MHz – $f_{dr}=5$ Hz; 168 MHz – $f_{dr}=6$ Hz; 223 MHz – $f_{dr}=9$ Hz.

The frequency drift of the CS for a short time (less than 10,000 s), as well as its short-term frequency instability, is shown in Fig. 5.

As an example of short-term instability, measurement results of the RL at the 168 MHz calibration point are taken. The CS has short-term instability with a value close to 1 Hz as can be seen from Fig. 5. For other calibration points, short-term instability charts are of the same character, therefore, are not given.

In order to evaluate the specified instability, it is necessary to investigate the CS at each calibration point within a certain time interval, which corresponds to at least one complete period of growth or decrease of frequency. The laboratories that took into account the short-term instability of the CS have got better measurement accuracy.

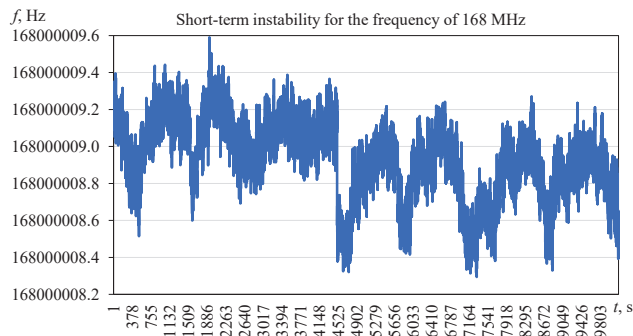

Fig. 5. Comparison sample frequency drift for a short time interval and short-term instability for a frequency of 168 MHz

5.3. Assessment of measurement uncertainty of assigned value

The measurement model has the following form:

$$f_x = \bar{f} + \delta f_s + \delta f_{sY} + \delta f_{SD} + \delta f_\tau, \tag{15}$$

where f_x – unknown actual value of frequency; \bar{f} – average value of the measured quantity (indications of the standard frequency meter); δf_s – correction due to deviations of the indications of the standard frequency meter (from the calibration certificate); δf_{sY} – correction due to the drift of the standard frequency meter since its last calibration; δf_{SD} – correction due to the discreteness of the indications of the standard frequency meter; δf_τ – correction due to the environmental impact.

The uncertainty budget of the assigned value is shown in Table 1. Extended uncertainties that are defined by the expression $U = ku(f_x)$ are for the frequency: 130 MHz – $U=0.24$ Hz; 168 MHz – $U=0.34$ Hz; 223 MHz – $U=0.38$ Hz. Measured values are respectively: 130000011.5 ± 0.24 Hz; 168000014.9 ± 0.34 Hz; 223000020.7 ± 0.38 Hz. These values are used by the RL to establish interlaboratory deviations of IC participants.

Table 1

The uncertainty budget of the assigned value

Quantity, X_i	Estimate x_i , Hz	Standard uncertainty, $u(x_i)$, Hz	Distribution	Sensitivity ratio, c_i	Contribution to uncertainty, $u_i(y)$, Hz
Frequency 130 MHz					
\bar{f}	130000011.5	0.12	normal	1.0	0.12
δf_s	-0.009	0.0013	normal	1.0	0.0013
δf_{sY}	0	0.01	normal	1.0	0.01
δf_{SD}	0	0.00000006	rectangular	1.0	0.00000006
δf_τ	0	0.01	normal	1.0	0.01
f_x	130000011.5	–	–	–	0.12
Frequency 168 MHz					
\bar{f}	168000014.9	0.17	normal	1.0	0.17
δf_s	-0.009	0.0013	normal	1.0	0.0013
δf_{sY}	0	0.01	normal	1.0	0.01
δf_{SD}	0	0.00000006	rectangular	1.0	0.00000006
δf_τ	0	0.01	normal	1.0	0.01
f_x	168000014.9	–	–	–	0.17
Frequency 223 MHz					
\bar{f}	223000020.7	0.19	normal	1.0	0.19
δf_s	-0.009	0.0013	normal	1.0	0.0013
δf_{sY}	0	0.01	normal	1.0	0.01
δf_{SD}	0	0.00000006	rectangular	1.0	0.00000006
δf_τ	0	0.01	normal	1.0	0.01
f_x	223000020.7	–	–	–	0.19

5.4. Results of the study of the comparison sample by IC participating laboratories

Table 2 and Fig. 6–8 show the results of IC: deviation of laboratory measurement results, extended uncertainty, E_n and z indicators.

Table 2

CS calibration results

Laboratory	Ref	Lab 1	Lab 2	Lab 3	Lab 4	Lab 5	Lab 6	Lab 7	Lab 8	Lab 9	Lab 10
Frequency 130 MHz											
D_{lab} , Hz	0.00	3.50	8.69	-1.81	-1.34	4.21	1.37	0.57	0.66	2.82	1.81
U_{lab} , Hz	0.27	80.09	13.01	30.99	80.42	4.30	2.42	4.94	52.10	32.00	11.33
E_n	–	0.04	0.67	-0.06	-0.02	0.98	0.56	0.12	0.01	0.09	0.16
z	–	0.83	2.98	-1.36	-1.17	1.12	-0.05	-0.38	-0.34	0.55	0.13
Frequency 168 MHz											
D_{lab} , Hz	0.00	2.12	8.48	-5.30	-4.64	2.40	-1.32	-2.83	-3.93	1.44	0.67
U_{lab} , Hz	0.45	82.63	12.22	40.06	80.42	4.30	3.13	6.70	67.26	30.00	12.27
E_n	–	0.03	0.69	-0.13	-0.06	0.56	-0.42	-0.42	-0.06	0.05	0.05
z	–	0.70	2.37	-1.25	-1.07	0.77	-0.20	-0.60	-0.89	0.52	0.32
Frequency 223 MHz											
D_{lab} , Hz	0.00	1.15	11.42	-6.31	-6.24	0.17	-0.73	-1.74	-0.58	2.04	1.12
U_{lab} , Hz	0.45	86.80	12.81	53.21	80.42	5.10	4.16	4.50	51.56	32.00	13.54
E_n	–	0.01	0.89	-0.12	-0.08	0.03	-0.17	-0.38	-0.01	0.06	0.08
z	–	0.42	5.07	-2.95	-2.92	-0.02	-0.43	-0.88	-0.36	0.83	0.41

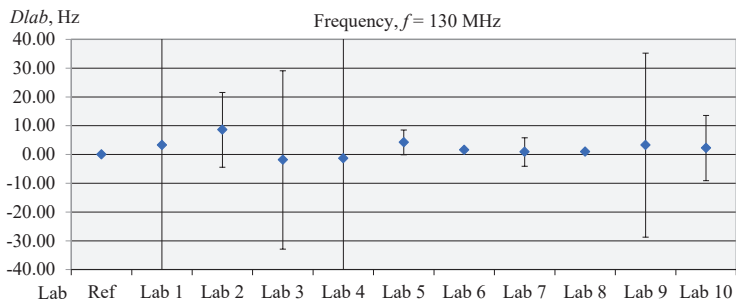

Fig. 6. Calibration results at a frequency of 130 MHz

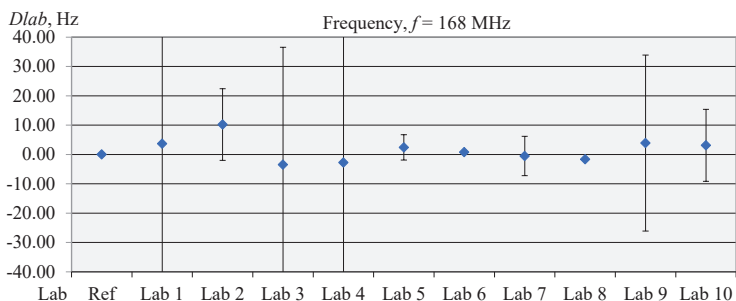

Fig. 7. Calibration results at a frequency of 168 MHz

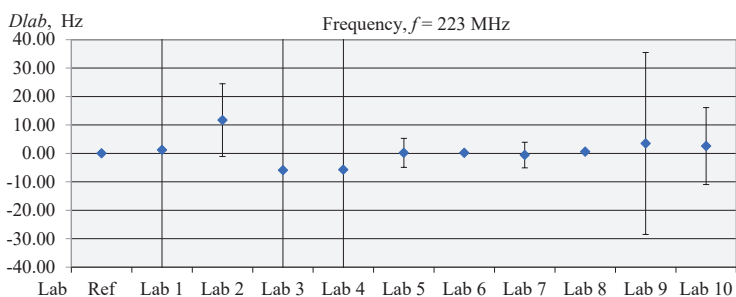

Fig. 8. Calibration results at a frequency of 223 MHz

IC results (Table 2 and Fig. 6–8) allow the development of specific recommendations for improving the performance of each IC participating laboratory.

6. Discussion of the results of the interlaboratory comparison of the calibration of the signal generator

Special BPSG6 OEM signal generator from Aaronia AG (Germany) was upgraded and calibrated as a CS in IC. The values of frequency drifts obtained by the expression (14) completely satisfy the requirements for these IC, since they do not exceed $3.4 \cdot 10^{-6} - 4.0 \cdot 10^{-6} \%$ of the frequency value of the calibration point (extremely small value). The long-term frequency drift for all three calibration points is negative (Fig. 2–4), insignificant and can be neglected when processing the IC results. The CS has short-term instability with a value close to 1 Hz (Fig. 5).

The coherence of the data obtained with the E_n and z indicators was evaluated. All IC participants, Lab 1–10 (Table 2) meet E_n indicator performance requirements at all calibration points (130 MHz, 168 MHz, and 223 MHz). This confirms the qualification of IC participants when performing calibration in accordance with the requirements of DSTU ISO/IEC 17025 [4].

Lab 3, Lab 4 at the 223 MHz calibration point have absolute z indicator values in the range of 2.0 to 3.0. Lab 2 has absolute values of the z indicator in the range from 2.0 to 3.0 at the calibration points of 130 MHz and 168 MHz and more than 3.0 at a calibration point of 223 MHz.

As can be seen, by the z indicator Lab 2 at one calibration point has a completely unsatisfactory result, and Lab 3 and Lab 4 have a satisfactory result. Accordingly, Lab 2 requires more significant correction measures to implement calibration of signal generators than Lab 3 and Lab 4, which also require some correction. That is, the indicated laboratories are advised to reconsider their corrections when calculating the measured frequency value and to take them into account in their own calibration methodologies.

Thus, it can be stated that the E_n indicator more closely characterizes the reliability of laboratory measurement results but is not always sufficient for determining the accuracy of measurement results, that is, the proximity of measurement results to the true value.

For this, the z indicator is more suitable, which compares measurement results of all laboratories and gives more information regarding the accuracy of laboratory measurements.

The assessment of data consistency using the E_n and z indicators is important not only for confirming the technical competence of IC participating laboratories in calibration in accordance with the requirements of DSTU ISO/IEC 17025. This will also contribute to enhancing the accuracy of the CS study for reducing the uncertainty of measurements carried out by IC participating laboratories.

7. Conclusions

1. The choice of methodology for processing the IC results based on long-term CS drift was made. The modernization and research of the CS are carried out by the RL for IC on the calibration of signal generators. Assigned values and their extended uncertainties for IC were determined. Expressions were obtained for the approximation of the long-term CS drift and uncertainty budgets for all assigned values of CS at 130 MHz, 168 MHz and 223 MHz were compiled.
2. The RL selected the necessary statistical performance criteria and evaluated the results of the CS study by IC participating laboratories. This is necessary to confirm the technical competence of IC participating laboratories in calibration in accordance with the requirements of DSTU ISO/IEC 17025.
3. The IC results on the signal generator calibration show that all IC participating laboratories meet the requirements of the E_n indicator. At the same time, one laboratory at one calibration point has a completely unsatisfactory result, while the other two – satisfactory result for the z indicator. This laboratory needs certain substantial corrective measures to implement calibration of signal generators. The other two laboratories at the same calibration point have a satisfactory result by the z indicator but need some correction to calibrate signal generators.

4. By the results of IC, we can conclude that the E_n indicator is not always self-sufficient. The E_n indicator more closely characterizes the reliability of laboratory measurement results, but is not always sufficient for determining the accuracy of measurement results, that is,

the proximity of measurement results to the true value. For this, the z indicator is more informative, which compares the results of measurements of all laboratories and gives more information about the accuracy of laboratory measurements.

References

1. International vocabulary of metrology. Basic and general concepts and associated terms (VIM). 3-rd ed. JCGM, 2012. URL: https://www.bipm.org/utis/common/documents/jcgm/JCGM_200_2012.pdf
2. ISO/IEC Guide 98-3:2008. Uncertainty of measurement. Part 3. Guide to the expression of uncertainty in measurement (GUM:1995). ISO/IEC, 2008. 130 p.
3. ILAC Policy on the Traceability of Measurement Results. ILAC. 2013. URL: http://www.enao-eth.org/publication_documents/ILAC_P10_01_2013%20ILAC%20Policy%20on%20Traceability%20of%20Measurement%20Results.pdf
4. DSTU ISO/IEC 17025:2006. General requirements for the competence of testing and calibration laboratories (ISO/IEC 17025:2005, IDT). Kyiv: Derzhspozhyvstandart Ukrainy, 2007. 32 p.
5. DSTU EN ISO/IEC 17043:2014. Otsinka vidpovidnosti. Zahalni vymohy do perevirky kvalifikatsiyi laboratoriy (EN ISO/IEC 17043:2010, IDT). Kyiv: Minekonomrozwytku Ukrainy, 2014. 21 p.
6. Velychko O., Gordiyenko T. Linking Results of International Comparisons of the National Standard and the National Inter-Laboratory Comparisons // *Journal of Physics: Conference Series*. 2018. Vol. 1065. P. 072004. doi: <https://doi.org/10.1088/1742-6596/1065/7/072004>
7. Interlaboratory comparisons of the calibration results of time meters / Velychko O., Shevkun S., Gordiyenko T., Mescheriak O. // *Eastern-European Journal of Enterprise Technologies*. 2018. Vol. 1, Issue 9 (91). P. 4–11. doi: <https://doi.org/10.15587/1729-4061.2018.121089>
8. Velychko O., Gordiyenko T. The implementation of general international guides and standards on regional level in the field of metrology // *Journal of Physics: Conference Series*. 2010. Vol. 238. P. 012044. doi: <https://doi.org/10.1088/1742-6596/238/1/012044>
9. Velychko O., Gordiyenko T. The estimation of the measurement results with using statistical methods // *Journal of Physics: Conference Series*. 2015. Vol. 588. P. 012017. doi: <https://doi.org/10.1088/1742-6596/588/1/012017>
10. Efremova N. Yu., Chunovkina A. G. Opyt ocenivaniya dannyh mezhlaboratornykh slicheniy kalibrovochnykh i poverochnykh laboratoriy // *Izmeritel'naya tekhnika*. 2007. Issue 6. P. 15–21.
11. Claudio J., Costa M. Brazilian energy interlaboratory program applicative // XX IMEKO World Congress «Metrology for Green Growth». Busan, 2012. 6 p.
12. Sandu I., Dragomir L., Pantelimon B. Interlaboratory comparison // 15th IMEKO TC 4 Symposium on Novelties in Electrical Measurements and Instrumentations. Iasi, 2007. 4 p.
13. Considerations on the influence of travelling standards instability in an interlaboratory comparison program / Sousa J. J. L., Leitão L. T. S., Costa M. M., Faria M. C. // XX IMEKO World Congress «Metrology for Green Growth». Busan, 2012. 4 p.
14. Active power quality assessment through interlaboratories comparison / Poenaru M. M., Iacobescu E., Anghel A.-C., Sălceanu A., Anghel M.-A. // 21th IMEKO TC4 International Symposium «Understanding the World through Electrical and Electronic Measurement». Budapest, 2016. P. 224–228.
15. Poenaru M. M., Iacobescu E., Anghel M.-A. Length calibration Quality assessment through Interlaboratories Comparison // 22th IMEKO TC 4 Symposium «Supporting World development through electrical and electronic measurements». Iasi, 2017. P. 20–26.
16. Final report on the supplementary comparison EURAMET.EM-S26: inductance measurements of 100 mH at 1 kHz (EURAMET project 816) / Dierixx E., Nestor A., Melcher J., Kölling A., Callegaro L. // *Metrologia*. 2012. Vol. 49, Issue 1A. P. 01002–01002. doi: <https://doi.org/10.1088/0026-1394/49/1a/01002>
17. Çaycı H. Final report on key comparison EURAMET.EM-K5.1 (EURAMET Project No. 687): Comparison of 50/60 Hz power // *Metrologia*. 2011. Vol. 48, Issue 1A. P. 01009–01009. doi: <https://doi.org/10.1088/0026-1394/48/1a/01009>
18. Final report on the APMP comparison of capacitance at 100 pF (APMP supplementary comparison APMP.EM-S7) / Johnson L., Chua W., Corney A., Hsu J., Sardjono H., Lee R. D. et. al. // *Metrologia*. 2008. Vol. 45, Issue 1A. P. 01003–01003. doi: <https://doi.org/10.1088/0026-1394/45/1a/01003>
19. CCEM-K5 Comparison of 50/60 Hz power / Oldham N., Nelson T., Zhang N. F., Liu H. // *Metrologia*. 2003. Vol. 40, Issue 1A. P. 01003–01003. doi: <https://doi.org/10.1088/0026-1394/40/1a/01003>
20. DSTU ISO 13528:2014. Statystychni metody, shcho zastosovuiutsia pry perevirtsi kvalifikatsiyi laboratoriyi shliakhom mizh-laboratornykh porivnian (ISO 13528:2005, IDT). Kyiv: Minekonomrozwytku Ukrainy, 2014. 29 p.