

**Обґрунтована доцільність системної діяльності транскордонних оперативно-рятувальних підрозділів завдяки створенню дуальних систем транскордонного пожежогашіння. Дуальні системи пожежогашіння – це тимчасово створені системи (на період ліквідації пожеж на кордонах) із ресурсів двох сусідніх держав для обмеження розвитку та ліквідації пожеж, а також захисту від них людей та матеріальних цінностей. Об'єктами конфігурації таких систем є кількість та склад технічних засобів для ліквідації пожеж, чисельність та фах пожежників-рятувальників, а також витратні матеріали для ліквідації пожеж. Виконано аналіз взаємозв'язків між об'єктами конфігурації дуальних систем транскордонного пожежогашіння та обґрунтована доцільність розроблення інструментарію для визначення результативності проектів створення дуальних систем.**

**Запропоновано три варіанти визначення результативності проектів створення дуальних систем транскордонного пожежогашіння. Вони лежать в основі розробленої геометричної моделі обґрунтування конфігурації проектів створення дуальних систем транскордонного пожежогашіння. Встановлено, що діапазон зміни параметрів пожежно-рятувальних підрозділів двох держав змінюється від 0 до 1, що впливає на результативність проектів створення дуальних систем транскордонного пожежогашіння.**

**Встановлено відсутність екстремуму залежності результативності проектів створення дуальних систем транскордонного пожежогашіння від кількості залучених сил і засобів двох сусідніх держав. Обґрунтована залежність максимального значення результативності проектів створення дуальних систем транскордонного пожежогашіння від її параметрів вказує на потребу врахування характеристик мінливого проектного середовища, а також організаційних складових цих проектів.**

**За результатами геометричного моделювання обґрунтовано взаємний вплив п'яти показників на результативність проектів створення дуальних систем транскордонного пожежогашіння**

**Ключові слова: проект, результативність, дуальна система пожежогашіння, транскордонний рятувальний підрозділ**

UDC 005.8+62-78+004.89

DOI: 10.15587/1729-4061.2019.175275

# SUBSTANTIATING THE EFFECTIVENESS OF PROJECTS FOR THE CONSTRUCTION OF DUAL SYSTEMS OF FIRE SUPPRESSION

**R. Ratushnyi**

PhD, Associate Professor, First Vice-Rector\*

E-mail: ratushnyi@ldubgd.edu.ua

**P. Khmel\***

E-mail: kafedra.itts@gmail.com

**A. Tryhuba**

Doctor of Technical Sciences, Professor

Department of Information Systems and Technologies

Lviv National Agrarian University

V. Velykoho str., 1, Dublyany, Ukraine, 80381

E-mail: trianamik@gmail.com

**E. Martyn**

Doctor of Technical Sciences, Professor\*

E-mail: evmartun@gmail.com

**O. Prydatko**

PhD\*

E-mail: o\_prydatko@ukr.net

\*Department of Project Management, Information

Technologies and Telecommunications

Lviv State University of Life Safety

Kleparivska str., 35, Lviv, Ukraine, 79007

Received date 07.06.2019

Accepted date 25.07.2019

Published date 30.08.2019

Copyright © 2019, R. Ratushnyi, P. Khmel, A. Tryhuba, E. Martyn, O. Prydatko.

This is an open access article under the CC BY license

(<http://creativecommons.org/licenses/by/4.0>)

## 1. Introduction

Enhancement of the activity of cross-border cooperation is accompanied by an increase in the risk of occurrence of emergency situations. This is especially true of fires of both natural and anthropogenic origin. At the same time, growth and complications of potential threats of occurrence of emergency situations at the borders requires the solution of the problem of ensuring the life security on both sides of the border. This is possible due to the interaction between mobile cross-border fire-rescue units of two countries.

Each of the two neighboring countries tries to solve independently the problems associated both with prevention, with the localization and liquidation of fires in their border area. Border areas and their sites are under the supervision of fire-rescue units that guard the nearby settlements and technical facilities. During the emergence of large-scale fires, their liquidation is complicated and becomes impossible due to the lack of forces and facilities of a fire rescue unit of a separate country. To ensure timely elimination of fires and saving lives and wealth, it is necessary to implement the projects of creation of temporary dual systems of cross-border fire suppression. By a dual system of cross-border fire suppression, we im-

ply temporarily created systems (for the period of liquidation of fires at the borders) from the resources of two neighboring states to restrict the development and elimination of fires, as well as to protect people and wealth from them.

The projects of creation of dual systems of cross-border fire suppression are implemented using the resources of fire-rescue units of two countries that border on each other. Completeness of fire-rescue units with forces and facilities is carried out taking into consideration the current requirements of the EU regulations. However, the resources available in each of the cross-border fire-rescue unit are different by their parameters. At the same time, both the duration of fire liquidation at the borders and its effectiveness depend on the parameters of the resources involved for implementing the projects of creation of dual systems of cross-border fire suppression. There occurs the managerial problem of substantiation of the effectiveness of the projects of creation of dual systems of cross-border fire suppression, which is solved at the stage of initiation of such projects. The characteristics of the obtained product of each project of creation of dual systems of cross-border fire suppression largely depend on the quality of its solution.

Toolset for the solution of the problem concerning substantiation of efficiency of the projects of creation of dual systems of cross-border fire suppression, unlike other kinds of projects, require consideration of a series of specific features. In particular, one should take into account the completeness of cross-border firefighting-rescue units, which are the main suppliers of resources for the implementation of the projects for creation of the dual systems of cross-border fire-fighting. The time and scale of projects of creation of dual systems of cross-border fire suppression depends on changing characteristics of the project environment, which for each cross-border territory is specific and predictable. The effectiveness of the projects of creation of dual systems of cross-border fire suppression largely depends on the duration and the quality of implementation of the processes of initiation of such projects.

Today, a series of projects relating to prevention and elimination of fires in border areas, as well as organization of training of representatives of fire-rescue units of stakeholders of the neighboring states in the region, have been implemented. At the same time, during the implementation of these projects, the above defined features of the projects of creation of dual systems of cross-border fire suppression were not taken into account. In addition, during their initiation, their effectiveness was not substantiated and the probable course of liquidation of an emergency (fire) of varying scale was not evaluated. All this points out the lack of a practical toolkit to support the effectiveness of projects of creating dual systems of cross-border fire suppression.

---

## 2. Literature review and problem statement

---

Today, in many countries of the world a considerable attention is paid to the problems of security of their population and territories thanks to the implementation of relevant projects. To do this, a series of regulations and standards were adopted. At the same time, scientists pay due attention to developing the toolkit (methods, models, algorithms, and computer programs) for design-oriented management. In particular, the well-known scientific papers deal with the

projects of protection of timber [1] and the woodlands [2, 3]. Scientific papers highlight new approaches to creating fire-rescue units that take into consideration specific features of their activity. However, it is impossible to use them during the implementation of the projects of creation of dual systems of cross-border fire suppression, since they do not take into account the features of resourcing, as well as the peculiarities of the project environment.

There are the known methods and models of substantiation of configuration of the projects and their project environment, which are the basis for making effective managerial decisions in the projects of creating fire-rescue units. Paper [4] examined the conditions of creation of fire-rescue departments of certain regions that carry out preventative supervision and liquidation of fires by available forces and facilities. However, they do not imply the involvement of additional forces and capabilities to enhance the effectiveness of the process of fire suppression.

Papers [5, 6] contain the results of solving the task of enhancing the quality of management of the processes of projects of creation of fire-fighting systems of separate regions. Thanks to the formulation of the system-value principles, models, methods and information media, a new toolkit of project management was proposed, however, it was only for the conditions of the regional development.

Paper [7], which presents the toolkit to support the portfolios of the projects of reengineering of the system of rural settlements, is worth paying attention. In this work, it is proposed to evaluate the characteristics of products for performing modeling of the projects of creation of fire-fighting units in rural settlements. However, the models and methods developed in this work cannot be used during the implementation of the projects of creation of dual systems of cross-border fire suppression, due to the fact that they do not take into account the features of cross-border cooperation and the formation of appropriate fire-rescue units.

There are known studies related to the development of models and information systems for management of the projects [8] and multi-parameter technical systems in the field of civil defense [9]. They partially consider the issues of project initiating and allocate the time for performing separate works as the main indicator of evaluation of performance of certain processes. However, these studies do not address the specifics of determining the duration of the execution of separate works in the projects of creation of dual systems of cross-border fire suppression.

In the projects of creation of dual systems of cross-border fire suppression, the quality of the substantiation of their configuration is quite important. The issue of substantiation of configuration of fire suppression systems for effective operation of the system is tackled in a series of scientific papers [10, 11]. The analysis indicates that the existing methods and models of substantiation of configuration of firefighting systems, including those in the border areas, are characterized by many shortcomings. In particular, they do not take into account the peculiarities of the changing project environment, which is specific for each administrative-territorial unit. These issues are also widely explored in the studies of the issues of proper organization of the population evacuation in the event of emergencies and disasters [12–14].

In general, it should be noted that the conducted analysis did not reveal any papers relating to the substantiation of the toolkit of management of the projects of creating dual systems of cross-border fire suppression. No studies focus-

ing on the substantiation of productivity of the projects of creation of cross-border firefighting units were found either. This suggests the need to develop the toolkit to substantiate the effectiveness of the projects of creation of dual systems of cross-border firefighting, since they differ from other types of projects both in content and resource support, and are characterized by the changing project environment.

### 3. The aim and objectives of the study

The aim of this study is to substantiate the effectiveness of the projects of the creation of dual systems of cross-border fire suppression, taking into account the peculiarities of realization based on modeling the operation of their products.

To accomplish the aim, the following tasks have been set:

- to represent the structure of the projects of creation of dual systems of cross-border fire suppression and to develop the model of substantiation of their effectiveness;
- to substantiate the tendencies of a change in the productivity of projects of creation of dual systems of cross-border fire suppression.

### 4. The structure of projects for construction of dual systems of cross-border fire suppression and the model of substantiation of their effectiveness

To ensure the elimination of separate fires on cross-border territories, temporary dual systems of cross-border fire suppression based on the implementation of relevant projects are created. These projects have the features of non-repeatability, restriction in resources and time. Their scope and life cycle are determined by the type and scope of fires on cross-border territories. The structural model and features of resourcing of the projects of creation of dual systems of cross-border fire suppression are shown in Fig. 1.

In order to ensure the elimination of a cross-border fire, it is necessary to realize the project of creation of a dual system of cross-border fire suppression, which is treated as an organizational and technical system. Such projects include hybrid projects, i.e. the projects that occur during the operation of cross-border firefighting-rescue units [5]. They consist of three interrelated subsystems “project management”, “project” and “project environment”. There are informational and material relationships among them. Specifically, information ( $I_n$ ) about the fire on the border enters the subsystem “project management”. After that project managers analyze information ( $I_1, I_2$ ) about the state of firefighting-rescue units of the one and the other state and on this basis take managerial decisions regarding the initiation of the project and involvement of resources ( $R_{e1}, R_{e2}$ ) of these two units for the implementation of the project. In addition, managerial decisions ( $U_d$ ) concerning actions in the project, as well as management decisions ( $U_1, U_2$ ) on the involvement of firefighting-rescue units of the one and the other state are substantiated in the subsystem “project management”.

The generalizing indicator for the estimation of projects to construct dual systems of

cross-border fire suppression is their effectiveness ( $R$ ). It is determined by the duration of suppression of a fire ( $t$ ), which causes the need for resources ( $R_{e1}, R_{e2}$ ) and the loss of human lives and wealth. The time of fire suppression is formed from its two components: the time of free combustion from the ignition moment to the beginning of its elimination by a firefighting-rescue unit, as well as the time of the fire suppression. In general, the first component is objective in nature and, to great extent, is determined by the information and the organizational component of getting ready (readiness) to the liquidation of emergencies. The time of being informed about a fire, the time of preparation of a firefighting-rescue unit and the time of being on the way are substantiated by the regulating documents that are aimed at its reduction.

The second component is fully determined by the readiness of a firefighting-rescue unit to extinguish a fire, that is, sufficient forces and facilities taking into account the scale of a fire. During the fire on the bordering territory on the sites for special purposes, a fire-rescue unit often lacks forces and facilities: the process of fire suppression can be completed with the involvement of additional forces and means of the neighboring state. Their involvement can result into time of delay  $\Delta t$  when eliminating a fire. Additional facilities may be given according to the project implementation immediately and to the full, or gradually, by a specific law, in the order determined by the situation. A joint organized cross-border operational-rescue unit appears during the time of the shared interaction of a fire-rescue department of neighboring states. It is obvious that the effectiveness of  $u$  and  $v$  of each unit is a component of effectiveness  $R$  of the elimination of a fire by a cross-border operational-rescue unit. The conducted analysis indicates the existence of five parameters of a cross-border operational-rescue unit that determine the result of its activity: time  $t$  of the elimination of a fire, forces and facilities of firefighting-rescue units of one  $x$  and the other  $y$  state. Accordingly, components  $u$  and  $v$  describe effectiveness  $R$  of its activity. In general, such parameters, like those for technical systems [9], are related by the visual dependences, manifold  $w$  of five-dimensional space of the state of the created dual system of cross-border fire suppression (Fig. 2).

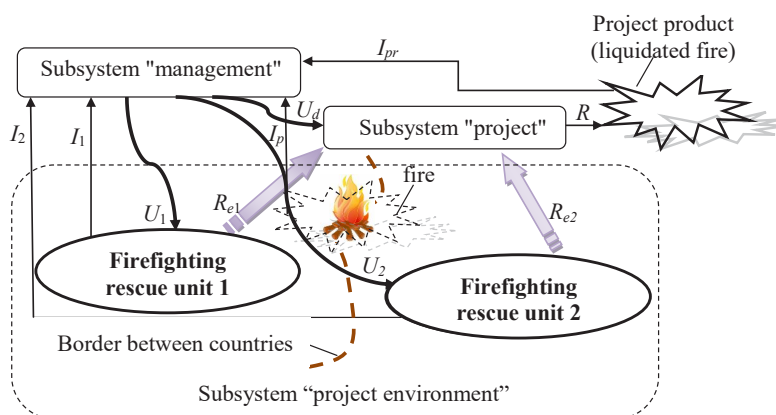

Fig. 1. The structure of projects of creation of dual systems of cross-border fire-suppression:  $R_{e1}, R_{e2}$  are respectively the resources of firefighting-rescue units of one and the other country;  $I_1, I_2$  are respectively the information about the site of fire-rescue units of one and the other country;  $I_p, I_{pr}$  are, respectively, the information about the cross-border fire and the results of project implementation;  $U_1, U_2$  are respectively managerial decisions about involvement of fire-rescue units of one and the other country;  $U_d$  is the managerial decisions on the actions in the project;  $R$  is project effectiveness

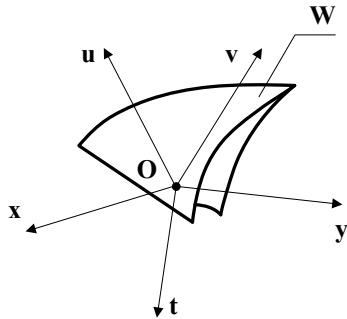

Fig. 2. Graphic interpretation of the dependence of parameters of the created dual system of cross-border fire suppression

It is possible to decrease the dimensionality of space by projecting manifold  $w$  onto subspace  $Oxyuv$  in the direction parallel to axis  $Ot$ . We obtain the phase space  $Oxyuv$  of the system, each point  $A_j$  of manifold  $R$  of which is determined for five studied parameters at the same time (Fig. 3).

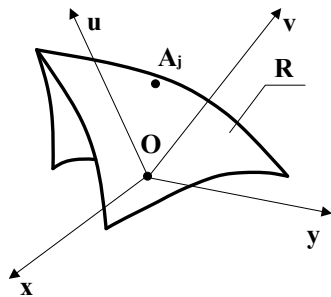

Fig. 3. Phase space of parameters of the created dual system of cross-border fire-suppression

Four-dimensionality of the phase space of the parameters of the created dual system of cross-border fire suppression allows using the geometry of two-dimensional complex space taking into account the characteristics of the system to study their effectiveness. Then the relationships  $x$  and  $y$  of forces and facilities will be represented by complex number  $Z=x+iy$  of extended complex plane, where  $i^2=-1$  is the imagined unit. Temporal dependences of effectiveness  $R$  and numbers  $x$  or  $y$  of a firefighting-rescue unit provide an opportunity to construct and establish the relationships of effectiveness of a dual system of fire-suppression and the amount of forces and facilities (Fig. 4).

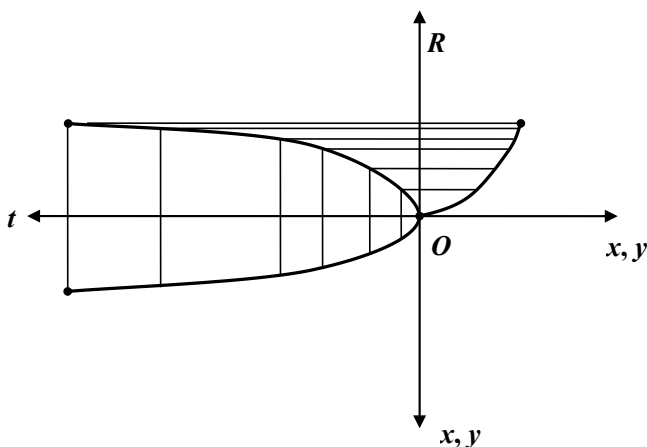

Fig. 4. Relationships between the parameters of the creation of the dual system of cross-border fire suppression

The dependence of effectiveness  $R$  on the amount of forces and facilities is the geometric place of the points of the plane of parameters, each of which determines the numeric value of effectiveness at the corresponding level of provision of units with amount  $x$  or  $y$  of forces and facilities.

We will write down the dependences of effectiveness  $R$  of the created dual system of cross-border fire suppression on the amount of forces and facilities  $Z=x+iy$ , and approximate them with parabolas of higher orders, taking into account the scale of fires, based on analysis (Fig. 4):

– small-scale fires  $M_p$

$$R=u+iv=Z=x+iy; \tag{1}$$

– medium-scale fires  $C_p$

$$R=u+iv=(Z)^2=(x+iy)^2; \tag{2}$$

– large-scale fires  $B_p$

$$R=u+iv=(Z)^3=(x+iy)^3. \tag{3}$$

Note that time  $t$  of fire increasing to the normal level is different and depends on their scale  $M$  (Fig. 5).

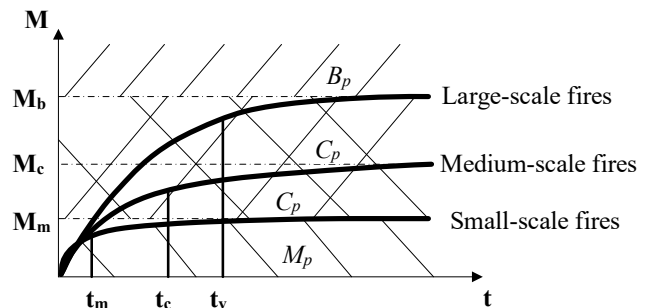

Fig. 5. Character of processes of fires development

Depending on the values for parameters of scalability  $M$  and time  $t$  of the development of fires, the character of the processes of their development can be conditionally divided into three zones: small  $M_p$ , medium  $C_p$  and large  $B_p$ . Taking into account these three zones is a prerequisite for the adequate display of the model of the course of the processes of interaction of a dual system of fire suppression.

Plot a graphical model of the effectiveness of the projects of creation of a dual system of cross-border fire suppression based on the structure of the phase space of the parameters of a dual system (Fig. 6).

The graphic model contains the relationships of the main parameters of the created dual systems of cross-border fire suppression considering the duration of the implementation of projects in zones 1–4, shown in Fig. 6, a. The means of geometric modeling provide wider opportunities for studying the correlations between the parameters of the created dual systems of cross-border fire-suppression (Fig. 6, b) in zones 5–8.

In particular, dependences of the duration of the action of forces and facilities of firefighting-rescue units of one  $x$  and the other  $y$  state are formed in planes 1, 2. Plane 3 gives the phase trajectories of the relationships  $x, y$  of the action of force and facilities of both firefighting-rescue units at the same time. Geometric images of plane 3 are the basis for the formation of reciprocal dependency of components  $u, v$

in plane 4 of integrated variables *Ouv*. The geometric toolset of the multidimensional space gives the opportunity to create additional dependences in planes 7, 8 by the previously constructed dependences in planes 5, 6.

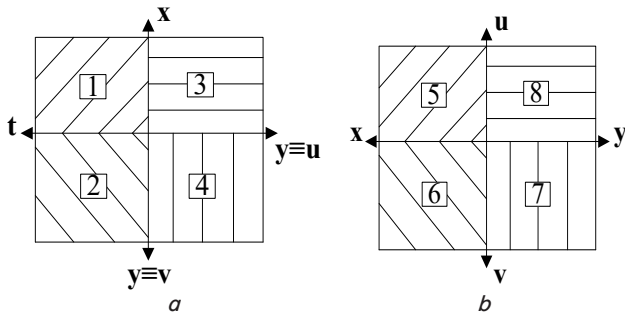

Fig. 6. Graphic model of effectiveness of the projects of creation of a dual system of cross-border fire suppression: *a* – important dependences of parameters of dual fire suppression systems; *b* – additional dependences of the parameters of a dual fire suppression system

**5. Results of substantiation of the tendency of a change in effectiveness of the projects for construction of dual systems of cross-border fire-suppression**

Effectiveness *R* of the projects of creation of dual systems of cross-border fire-suppression is determined by the duration of their implementation, which creates the need for resources and losses from fires. At the same time, we accept nominal values of parameters *x, y* as equal to unity according to the requirements of the regulatory documents. Then, for dependences (1) to (3), the values of effectiveness *R* for one firefighting-rescue unit at the standard amount of forces and facilities in the given project environment are also equal to unity. During the studies, we accept the working range of a change in parameters *x, y* in relation to the amount of forces and facilities, as well as effectiveness *R* as non-negative magnitudes that are within 0...1.

Consider the influence of time  $\Delta t$  of the delay in the arrival of the additional forces and facilities of the other firefighting-rescue unit on the process of suppression of a large-scale fire and effectiveness *R* of a cross-border operational-rescue unit. Accept, for example, the provision of the first operational-rescue unit with forces and facilities  $x=0.9$  of the standard, and the other – in the amount of 0.3 of the required amount (Fig. 6). The times of the delay of the other are equal to, respectively,  $t_1=0.2$  and  $t_2=0.6$  for two cases of liquidation of medium-scale fires (lines 1, 2).

In the absence of the delay of forces and facilities of the first operational-rescue subunit, time components of the delay in arrival of additional forces and facilities for both cases make up, respectively,  $\Delta t_1=0.2$  and  $\Delta t_2=0.6$ .

We have (Fig. 7) the fact that the dependence of two parameters *x, y* of forces and facilities belonging to the components of a cross-border operational-rescue unit is represented by one point A for both values of time  $t_1$  and  $t_2$ .

Effectiveness *R* of the projects of creation of dual systems of cross-border fire suppression can be written down as:

$$R = u + iv = x^2 - y^2 + 2ixy = 0.9^2 - 0.3^2 + 2i \cdot 0.9 \cdot 0.3 = 0.72 + 0.54i \tag{4}$$

The above is represented by point *B* of plane *Ouv*. In this case, the largest value is determined from expression:

$$|R| = \sqrt{u^2 + v^2} = \sqrt{(x^2 - y^2)^2 + 4x^2y^2} = \sqrt{x^4 + y^4 - 2x^2y^2 + 4x^2y^2} = \sqrt{(x^2 + y^2)^2} = x^2 + y^2 \tag{5}$$

Thus, the highest value of effectiveness *R* of the projects of creation of dual systems of cross-border fire suppression does not depend on the time of delay of the arrival of additional forces and facilities.

The absence of the influence of the time of arrival of additional forces and facilities on effectiveness *R* of a cross-border operational-rescue unit can be explained by the fact that its activity starts from moment  $t_1$  or  $t_2$  due to uniting its both components.

Thus, it is very important that time  $\Delta t$  and time constant time  $t_c$  of combustion should be at least co-dimensional for a medium-scale fire. This can be achieved through the improvement of the relationships of separate phases of the implementation of corresponding projects. The important element of decrease  $\Delta t$  is the implementation of organizational and technical measures. Among them, it is necessary to separate the problem of agreement of the configuration of the created cross-border operational-rescue units of different states. The first operational-rescue unit is equipped with such amount of forces and facilities that ensure the elimination of fires in the border area serviced by it. A possible lack of necessary forces and facilities for elimination of fires on separate sites and transport cargo that move across the border requires the implementation of organizational measures at the international level. In this case, it is necessary to harmonize the available forces and facilities, which are involved in implementing the projects of fire suppression. Implementation of the main components of a project configuration is effective on condition of strengthening and development of the information component. Under conditions of the project implementation, it is necessary to predict the state of the transport infrastructure, in particular, the state of cross-border routes, as well as to take into account the technical equipment with firefighting facilities of separate sites and cargoes that moved across the border (Fig. 8).

Consider the character of the change of effectiveness *R* of the projects of creation of dual systems of cross-border fire suppression at the change of the amount of additional forces and facilities within 0...1 for  $x=0.9$ . Dependence  $x=f(y)$  is represented by the set of points belonging to straight line 3 of complex plane *Oxy*. It corresponds to the character of a change in effectiveness *R* of curve 4 in complex plane *Ouv*.

An increase in the amount of the additional forces and facilities *y*, for example,  $y=0.5, y=0.7, y=0.9, y=1$  (Fig. 7), at the constant value *x*, specifically,  $x=0.9$ , is the cause of a decrease in effectiveness of *u* and an increase in effectiveness of *v*. Emphasize that at the equal values  $x=y=0.9$ , component  $u=0$ , and at the same time, component  $v=0$  at value  $y=0$ . At values  $x < y$ , component  $u < 0$ , and component *v* increases.

A decrease in the amount *x* of forces and facilities, which are involved for the realization of projects of creating dual systems of cross-border fire suppression, for example,  $x=0.7$  at  $y=0.3, 0.5, 0.7, 0.9, 1$ , does not affect the nature of changes in effectiveness (curve 5). However, both components of the efficiency decrease, and the transition of *u* to the negative area takes place at corresponding smaller values ( $x=0.7$ ). To ensure the positive values of *u*, it is necessary to satisfy the ratio  $x > y$ : for each value of *x*, corresponding values of *y* are limited

by straight line  $y=x$  (the cross hatched area of plane  $Oxy$ ). A decrease in  $x$ , the amount of forces and facilities of firefighting-rescue unit, is the reason to argue about a decrease in effectiveness  $R$  of the cross-border operational-rescue unit at any values of  $y$ : module of vector  $|\vec{R}|$  decreases, and its transition to the negative region occurs at smaller values of  $x$ . At an increase in the amount of additional forces  $y$  and constant  $x$ , for example,  $x=0.7$ , vector  $\vec{R}$  moves clockwise from the highest value of  $u$  to the highest value of  $v$  (arrows in Fig. 7)

The conducted numerical analyses using a geometrical model gives grounds to substantiate the following principles of the influence of project management of forces and facilities  $x, y$ , of both firefighting-rescue units on effectiveness  $R$  of the projects of creation of dual systems of cross-border fire suppression:

$$R = u + iv = Z^2 = x^2 - y^2 + 2xyi = (x-y) \times (x+y) + 2xyi. \quad (6)$$

Involvement of additional forces and facilities  $y$  has dual influence on the effectiveness  $u = (x-y)(x+y)$  of an operational-rescue unit, their involvement both decreases  $(x-y)$ , and enhances the value of  $u$ :  $u$  gains the highest value at  $y=0, u=x^2$ , and the least at  $x=y$ .

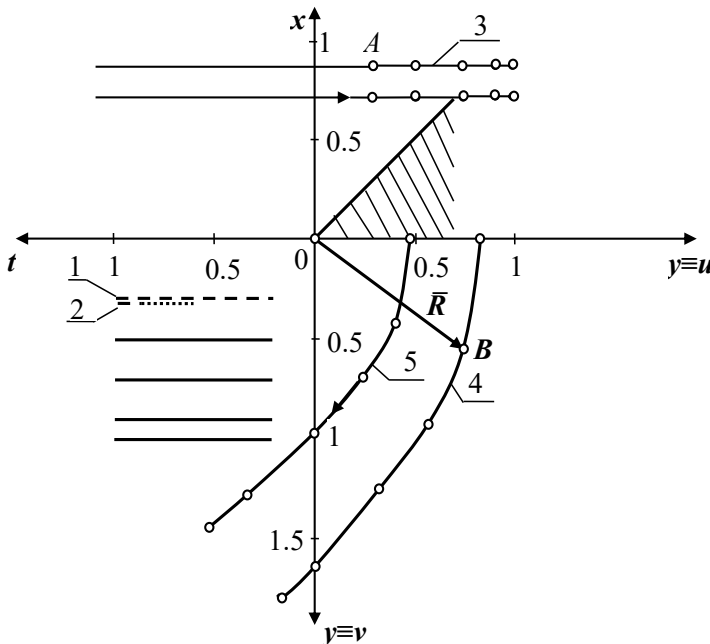

Fig. 7. Graphic dependences of configuration of dual systems of cross-border fire suppression

Additional capabilities in has a twofold impact on the effectiveness of  $u = (x-y)(x+y)$  operational fire units: their involvement as worsens  $(x-y)$ , and  $(x+y)$  values of  $u$ : top value  $u$  gets when  $y=0, u=x^2$ , and the lowest at  $x=y$ :

$$u = (x-x)(x+x) = 2x \cdot 0 = 0. \quad (7)$$

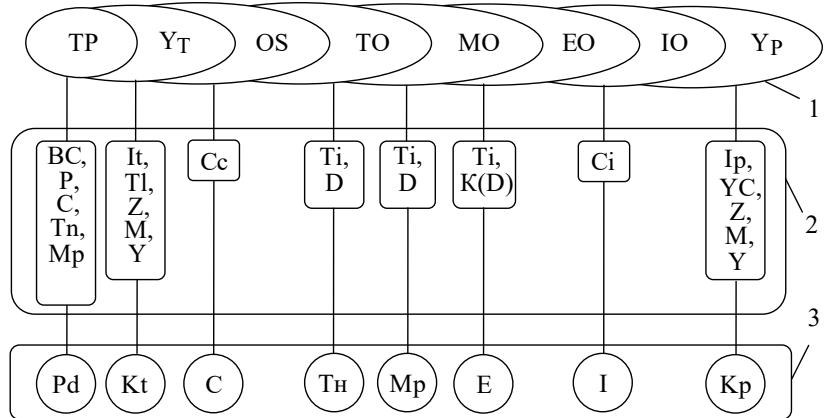

Fig. 8. Reference structure of the processes of projects of creation of dual cross-border fire suppression systems (1), basic functional components (2), which ensure corresponding processes and their results (3): TP, Y<sub>T</sub>, OS are, respectively, the technological processes, processes of their management, processes of provision with executors (firefighters-rescuers); TO, MO, EO, IO, Y<sub>p</sub> are, respectively, the processes of provision with equipment, material, power, financial and information resources, as well as the processes of management of corresponding project (projects); Bc, Pd, C, T<sub>n</sub> are, respectively, project environment, project products, executors (firefighters-rescuers) and technical facilities; M<sub>p</sub>, E, I are, respectively, material, power and information resources; K<sub>t</sub>, K<sub>p</sub> are the orders to implement technological processes and the project (projects); It, Ip are, respectively, the information about the course of technological processes and project (projects) implementation; Tl, YC, Z, M, Y are, respectively, technologies, standards on project management, management tasks, methods for their solution and managers; Cc, Ci, Ti are, respectively, the systems of provision with executors and information, as well as the transport infrastructure; D, K are the roads and communications

In turn, effectiveness  $v = 2xy$  of the involved additional forces and facilities  $y$  has a reverse property: it acquires maximum value at  $x=y, v=2xy=2y^2$ , and the minimum value at  $x=0$ .

### 6. Discussion of results of substantiation of effectiveness of the projects for construction of dual systems of cross-border fire-suppression

The obtained results indicate that the effectiveness of the projects of creation of dual systems of cross-border fire suppression largely depends on the proper training of a firefighting-rescue unit, availability of relevant regulatory documents on the formation of forces and facilities, as well as the opportunity to involve additional forces and facilities. Thus, the proper level of effectiveness can be obtained in the absence of one of the units of:  $u=x^2$  or  $v=y^2$ , and the other variant, obviously, is not cost-effective, given time  $\Delta t$  of the delay of additional capabilities. Analysis of Fig. 7 and dependence (6) shows that it is better to involve additional forces and facilities  $y$  at maximum values of completeness of the first firefighting-rescue unit with forces and facilities  $x$ . Thus, design-oriented management should, above all, ensure coordination of resources in the projects of creation of dual systems of cross-border fire-fighting, provided by separate states, with predictable characteristics of the project environment.

In order to predict the characteristics of the project-based environment, first of all, it is necessary to carry out the project analysis of probable fire situations in border

areas. To do this, it is necessary to identify unusual dangerous sites, loads, structures that require fire protection of the firefighting-rescue units that serve the border region. Considering fire safety, it is essential to implement additional projects of the creation of dual systems of cross-border fire-suppression. In this case, special attention should be paid to the relocation across the border of fire-hazardous substances or objects. Firefighting-rescue units have to be notified in advance and should have reliable information on the way of their moving across the border. These specified projects with the involvement of additional forces and facilities, if necessary, are implemented on their basis. Given the dangerous lack of influence of delay time (Fig. 6), involvement of the own additional capabilities without crossing the border, as well as the coherence of the project configurations with two components (firefighting-rescue units of two states) should be considered the best option.

Effectiveness of the project of creation of the dual system of cross-border firefighting acquires its maximum value  $|R|=2$  at norm values  $x=y=1$ . At the same time, for function (7), extremum is absent both in its three-dimensional projections  $u=f(x, y)$  (Fig. 9, a),  $v=f(x, y)$  (Fig. 9, b), and in the four-dimensional space. This, in turn, indicates the absence of the opportunity to find the optimal values of forces and facilities  $x$  and  $y$  in working range  $[0...1]$  of changes in these parameters or within the norms of their provision.

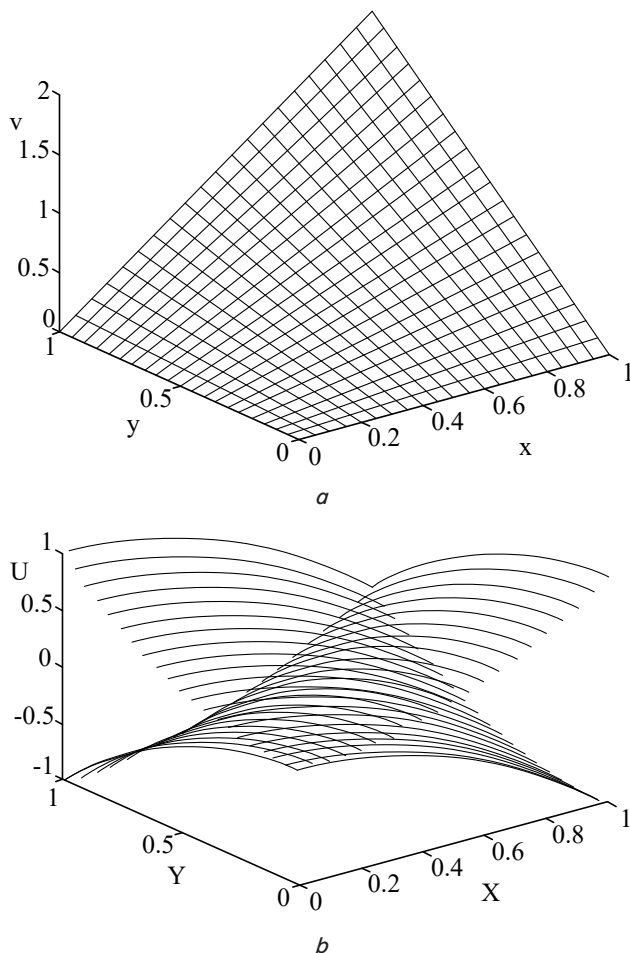

Fig. 9. Projections of effectiveness  $R$  of the projects of creating dual systems of cross-border fire-suppression:  
 a – effectiveness of firefighting-rescue unit 1;  
 b – effectiveness of firefighting-rescue unit 2

Analyzing the relationships between the components of effectiveness of the projects of creation of a dual system of cross-border fire suppression, it is evident that project configuration  $K_{pr}$  depends on the configurations of firefighting-rescue units of one  $K_1$  and the other  $K_2$  state:

$$K_{pr}=f(K_1, K_2). \tag{8}$$

At the same time, configuration  $K_1$  of a separate firefighting-rescue unit of the separate state is conditioned by the configuration of project environment  $K_{ps}$  and configuration  $K_2$  of the other firefighting-rescue unit of the neighboring state:

$$K_1=f(K_2, K_{ps}). \tag{9}$$

These configurations influence the effectiveness  $u$  and  $v$  of the activity of each firefighting-rescue unit:

$$u(v)=f(K_1, K_2, K_{pr}, t, \Delta t), \tag{10}$$

where  $t$  is the duration of fire suppression.

At the same time, the duration of fire suppression depends on:

$$t=f(K_1, K_2, K_{pr}, \Delta t), \tag{11}$$

where  $\Delta t$  is the duration of arrival of additional forces and facilities of the other firefighting-rescue unit. The conducted model analysis proves the coherence of component configurations  $K_{pr}$  of the project of creation of a dual system of cross-border fire-suppression with the involvement of two firefighting-rescue units with amount  $x, y$  of forces and facilities. Hence, coherence of configurations of projects  $K_1$  and  $K_2$  influences directly time components (11) of fire suppression, according to the tuple:

$$t^{-1}=R=f(u, v)=f(u(x, K_1, K_{pr}, \Delta t), v(y, K_2, K_{pr}, \Delta t)). \tag{12}$$

The research was conducted by idealization that firefighting-rescue units of two countries have the same regulatory requirements for the duration of response and the time of delivery of firefighting units to fire sites. In addition, the performed studies are limited to the number of states (two neighboring states) involved in the implementation of projects of creation of dual systems of cross-border fire suppression. However, the identified relationships (8) to (12), as well as dependence (6) are the basis for subsequent development of the scientific-methodological fundamentals of the management of projects of creation of dual systems of cross-border fire suppression. In particular, in practice there are cross-border territories, which determine bordering of three states. This requires further theoretical studies, which will give the opportunity to develop the toolkit and substantiate the tendencies of a change in the effectiveness of the projects of creation of systems of cross-border fire suppression from the resources of three states.

### 7. Conclusions

1. The developed geometrical model of substantiation of the effectiveness of the projects of creation of dual systems of cross-border fire suppression takes into account the

variables of amount  $x$  and  $y$  of involved forces and facilities of cross-border operational-rescue units of both states, duration of project implementation and is the basis of their planning at the stage of initiation. To take into account the reciprocal influence on each of the components  $u$  and  $v$  of the effectiveness of the projects of creation of dual systems of cross-border fire suppression, we used the design-oriented approach and geometric modeling of their operation using the tools of multi-dimensional applied geometry.

2. The tendencies of a change in the components of effectiveness of the projects of creation of dual systems of cross-border fire suppression were substantiated based on

geometric modeling. They indicate that resource provision with cross-border operational-rescue units depends on the type of a fire and characteristics of the project environment. In addition, they have a reciprocal influence on five indicators of the effectiveness of the projects of creation of dual systems of cross-border fire suppression and result in limited use of additional capabilities. A decrease in the duration of the projects of creation of dual systems of cross-border fire suppression is possible at acquiring maximum values  $x$  of provision of a firefighting-rescue unit with the resources belonging to separate components of the cross-border operational-rescue unit.

## References

1. Vasiliev, M. I., Movchan, I. O., Koval, O. M. (2015). Diminishing of ecological risk via optimization of fire-extinguishing system projects in timber-yards. *Scientific Bulletin of National mining university*, 5, 106–113.
2. Zaver, V. B. (2012). Method of management by project configuration of the of fire protection system improvement at the mountain forest district. *Eastern-European Journal of Enterprise Technologies*, 1 (11 (55)), 16–19. Available at: <http://journals.uran.ua/eejet/article/view/3592/3365>
3. Smotr, O., Borzov, Y., Burak, N., Ljaskovska, S. (2018). Implementation of Information Technologies in the Organization of Forest Fire Suppression Process. 2018 IEEE Second International Conference on Data Stream Mining & Processing (DSMP). doi: <https://doi.org/10.1109/dsmp.2018.8478416>
4. Tryhuba, A., Ratushny, R., Bashynsky, O., Shcherbachenko, O. (2018). Identification of firefighting system configuration of rural settlements. *MATEC Web of Conferences*, 247, 00035. doi: <https://doi.org/10.1051/mateconf/201824700035>
5. Shcherbachenko, O. (2017). Organizational and technological backgrounds of project configuration management for firefighting. *TEKA an international quarterly journal on motorization, vehicle operation, energy efficiency and mechanical engineering*, 17 (3), 49–53.
6. Scherbachenko, O. (2018). Establishing scenarios of fire extinguishing systems development in united territorial communities. *Bulletin of Lviv State University of Life Safety*, 17, 14–22. doi: <https://doi.org/10.32447/20784643.17.2018.02>
7. Bondarenko, V. V. (2014). Obgruntuvannya portfeliv proektiv reinzhynirynhu system pozhezhohasinnia silskykh poselen. *Lviv*, 18.
8. Prydatko, O., Pasnak, I. (2017). Investigation of the processes of the information technologies integration into the training of specialists at mine rescue departments. *Scientific Bulletin of National mining university*, 1, 108–113.
9. Ljaskovska, S., Martyn, Y., Malets, I., Prydatko, O. (2018). Information Technology of Process Modeling in the Multiparameter Systems. 2018 IEEE Second International Conference on Data Stream Mining & Processing (DSMP). doi: <https://doi.org/10.1109/dsmp.2018.8478498>
10. Zachko, O. B. (2014). Models of the civil protection system development using engineering infrastructure projects. *Central European journal for science and research*, 4, 33–38.
11. Marrion, C. E. (2016). More effectively addressing fire/disaster challenges to protect our cultural heritage. *Journal of Cultural Heritage*, 20, 746–749. doi: <https://doi.org/10.1016/j.culher.2016.03.013>
12. Zachko, O., Golovatyi, R., Yevdokymova, A. (2017). Development of a simulation model of safety management in the projects for creating sites with mass gathering of people. *Eastern-European Journal of Enterprise Technologies*, 2 (3 (86)), 15–24. doi: <https://doi.org/10.15587/1729-4061.2017.98135>
13. Lovreglio, R., Ronchi, E., Nilsson, D. (2015). A model of the decision-making process during pre-evacuation. *Fire Safety Journal*, 78, 168–179. doi: <https://doi.org/10.1016/j.firesaf.2015.07.001>
14. Hulida, E., Pasnak, I., Koval, O., Tryhuba, A. (2019). Determination of the Critical Time of Fire in the Building and Ensure Successful Evacuation of People. *Periodica Polytechnica Civil Engineering*, 63 (1), 308–316. doi: <https://doi.org/10.3311/ppci.12760>