

*З метою мінімізації реактивної потужності та вищих гармонік струмів, а також поліпшення електромагнітної сумісності мереж тягового електропостачання та систем залізничної автоматики на сучасному електричному рухомому складі змінного струму використовують активні чотириквADRANTні випрямлячі. Класичною топологією даного перетворювача є дворівневий повномостовий активний випрямляч, який забезпечує коефіцієнт потужності близький до одиниці та рекуперацію енергії в мережу живлення. Однак висока частота комутації зумовлює високі динамічні втрати в силових транзисторах та низьке значення ККД.*

*Перспективним є використання трирівневих активних чотириквADRANTних випрямлячів з корекцією коефіцієнта потужності. В роботі запропонована система керування трирівневого активного випрямляча з двоканальною рівне-зсунутою синусоїдальною ШІМ. Перевагою запропонованого алгоритму керування у порівнянні з відомими є покращення якості вхідного струму та зниження частоти комутації силових ключів, що призводить до зменшення втрат потужності та збільшення ККД випрямляча. Представлено результати порівняльного аналізу залежностей втрат потужності та ККД від частоти комутації силових ключів для дворівневого й трирівневого активного випрямляча з запропонованою системою керування, який підтвердив доцільність запропонованої системи керування. У програмі Matlab 2017b проведено імітаційне моделювання дворівневого та трирівневого активного випрямляча, на підставі якого здійснено аналіз параметрів якості електричної енергії, визначено залежність коефіцієнта гармонічних спотворення вхідного струму активного випрямляча від частоти комутації силових ключів. На підставі проведених досліджень доведена технічна та економічна доцільність використання схеми трирівневого активного випрямляча з системою керування на базі двоканальної рівне-зсунутої синусоїдальної ШІМ*

*Ключові слова: трирівневий активний випрямляч, широтно-імпульсна модуляція, частота комутації, коефіцієнт потужності, енергоефективність*

UDC 621.316.1

DOI: 10.15587/1729-4061.2019.174112

## IMPROVING ENERGY CHARACTERISTICS OF AC ELECTRIC ROLLING STOCK BY USING THE THREE-LEVEL ACTIVE FOUR-QUADRANT RECTIFIERS

**O. Plakhtii**

PhD, Electronic Engineer

Limited Liability Company «VO OVEN»

Hvardiitsiv-Shyronivtsiv str., 3A, Kharkiv, Ukraine, 61153

E-mail: a.plakhtiy1989@gmail.com

**V. Nerubatskyi**

PhD, Associate Professor\*

E-mail: NVP9@i.ua

**D. Sushko**

PhD, Associate Professor\*

E-mail: Dimals80@i.ua

**I. Ryshchenko**

Doctor of Technical Sciences, Professor, Director

Institute of Chemical Technology and Engineering

National Technical University «Kharkiv Polytechnic Institute»

Kyrpychova str., 2, Kharkiv, Ukraine, 61002

E-mail: ihtidirection@gmail.com

**V. Tsybulnyk\***

E-mail: naytus2244@gmail.com

**D. Hordiienko**

Engineer

Private JSC «ELAKS»

Ak. Proskury str., 1, Kharkiv, Ukraine, 61085

E-mail: D.Hordiienko@i.ua

\*Department of Electric Power Engineering, Electrical

Engineering and Electromechanics

Ukrainian State University of Railway Transport

Feierbakha sq., 7, Kharkiv, Ukraine, 61050

Received date 23.04.2019

Accepted date 01.07.2019

Published date 19.08.2019

Copyright © 2019, O. Plakhtii, V. Nerubatskyi, D. Sushko, I. Ryshchenko, V. Tsybulnyk, D. Hordiienko

This is an open access article under the CC BY license

(<http://creativecommons.org/licenses/by/4.0>)

### 1. Introduction

The input converters of electric rolling stock (ERS) of alternating current are most typically the diode and thyristor rectifiers. These converters predetermine the supply of reactive power from a power network, as well as

are a cause of a significant emission of higher harmonics of used currents. This leads to an increase in the additional losses in electricity supply systems [1–3], as well as the deterioration of electromagnetic compatibility between electrical traction networks and systems of railroad automation [4, 5].

In recent years, electric rolling stock has increasingly employed the two-level active four-quadrant rectifiers that are referred to as 4QS-rectifiers [6, 7]. The structure of an AC traction electric drive in the electric locomotive with a two-level 4QS-rectifier is shown in Fig. 1. Their advantage in comparison with classic diode and thyristor rectifiers is the possibility to implement a sinusoidal form of the used current, ensuring the value for a power factor close to unity (>99 %) and energy recuperation to a power network. In addition, a possibility to smoothly adjust the start of electric rolling stock makes it possible to reduce dynamic loads on its mechanical component [8]. However, a given topology is not devoid of flaws.

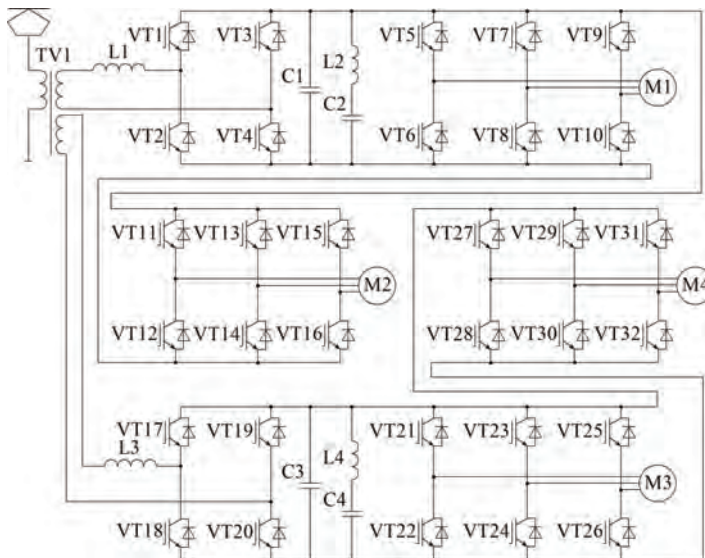

Fig. 1. Structure of the traction electric drive of an AC electric locomotive with the input two-level 4QS-converters

Among the drawbacks of the two-level 4QS-rectifiers that must be paid attention to is the need to apply the high-voltage IGBT switches.

In this case, the necessity for the formation of a high switching frequency of power switches leads to rather large dynamic losses in the power switches with a lower efficiency in comparison with the diode and thyristor rectifiers. In this regard, it is a relevant task to search for solutions aimed at improving the efficiency of active four-quadrant rectifiers.

## 2. Literature review and problem statement

The value for the implemented energy characteristics of active rectifiers largely depends on the chosen algorithm of modulation and the selected power circuit.

Papers [9, 10] report results of research into the two-level active rectifiers the system of control over which is based on the hysteresis modulation. The disadvantage of control systems over active rectifiers with the hysteresis algorithm of key switching is a variable and very high switching frequency of power transistors (exceeding several tens of kHz). The high switching frequency predetermines, on the one hand, the high quality of electricity, but on the other hand

it creates high dynamic losses in power transistors and a low value for efficiency.

Study [11] reports results of research into a two-level active rectifier with the control system (CS), which is built on the pulse width modulation (PWM). The presence of PWM in CS makes it possible to ensure a lower and constant switching frequency of power switches ( $\approx 1$  kHz), which leads to smaller dynamic losses and increased efficiency. However, a decrease in the switching frequency of power switches leads to the pronounced decline in the quality of electricity.

Work [12] investigated an increase in the sinusoidality of the input current in active two-level rectifiers with PWM, which was achieved when implementing the algorithm of interleaving. Interleaving is the mode of mutual compensation of higher harmonics in input currents in two or more converters, which are connected to the same power grid. However, the algorithms of interleaving can be used only in systems that employ several active rectifiers, connected to the same network.

Papers [13, 14] report research into comparative indicators of losses in power IGBT switches of different classes. For ERS, the circuit of the two-level active rectifier of switches must employ switches of a higher class (6.5 kV, or 4.5 kV) in terms of the rated voltage, which have, in comparison to switches of the lower class of voltage, the larger values of static and dynamic losses. This leads to excessive power losses in a converter. Based on these studies, the authors suggested a hypothesis on that the promising way to improve energy efficiency of the AC electric rolling stock is to apply the topology of a three-level active rectifier (Fig. 2).

Fig. 2 shows a current collector, an input step-down transformer, a three-level active rectifier, capacitive filter, and the equivalent RL-load.

Compared to a two-level active rectifier, the circuit of a three-level active rectifier includes twice the number of IGBT-transistors and four additional power diodes. However, the three-level circuit makes it possible to use switches with a rated voltage that is two times lower. Thus, it is the unsolved technical task to study and substantiate the use of a single-phase circuit of the three-level active rectifier for AC ERS.

It is worth noting that up to now the electric rolling stock of alternating current has not used a circuit of the three-level active rectifier.

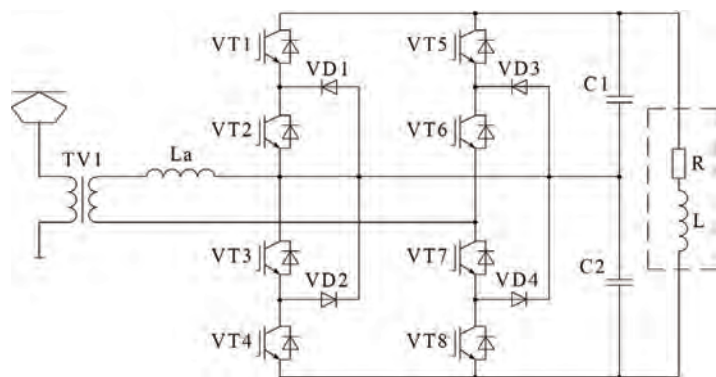

Fig. 2. Circuit of a three-level active rectifier

### 3. The aim and objectives of the study

The aim of this study is to improve the energy efficiency of AC electric rolling stock by using the three-level active rectifiers under a traction mode, which is achieved by decreasing the emission of reactive power, by reducing the emission of higher harmonics of the input current and by enhancing performance efficiency.

To accomplish the aim, the following tasks have been set:

- to determine power losses, energy and cost characteristics of power IGBT-transistors for the two-level or three-level active rectifier;
- to establish the dependence of efficiency of the two-level and three-level active rectifier on the switching frequency of power switches;
- to describe the proposed algorithm for controlling power switches in the three-level active rectifier, which ensures improvements in the sinusoidality of input current;
- to establish the dependence of a harmonic distortion factor of the input current in the active rectifier on the switching frequency of power switches;
- to justify an energy saving effect from the application of a three-level active rectifier's topology with the proposed control system based on the two-channel phase-shifted sinusoidal PWM by the simulation modelling.

### 4. Comparison of power losses in the two-level and three-level active rectifier with a classic sinusoidal pulse-width modulation

It is possible to determine power losses in IGBT-transistors by calculating the static  $P_{DC}$  and dynamic  $P_{SW}$  losses in IGBT-transistors and parallel diodes [14, 15].

$$P = P_{DC} + P_{SW}, \quad (1)$$

where  $P_{DC}$  are the static losses in IGBT-transistors;  $P_{SW}$  are the dynamic losses in IGBT-transistors.

The process of switching the current and voltage in IGBT-switch and the graphical distribution of static and dynamic losses are shown in Fig. 3.

The static losses in IGBT-transistors  $P_{DC}$  are determined from expression:

$$P_{DC} = \frac{1}{2\pi} \cdot \int_0^\pi (I_c \cdot V_{ce}(I_c) \cdot D_{on}) \cdot dt, \quad (2)$$

where  $I_c$  is the current in a collector;  $V_{ce}(I_c)$  is the voltage between a collector and emitter, which depends on the magnitude of current in a collector (dependence  $V_{ce}(I_c)$  is given in the specifications for the transistor);  $D_{on}$  is the PWM fill factor.

The dynamic losses in IGBT-transistors  $P_{SW}$  are determined from expression:

$$P_{SW} = \frac{1}{2\pi} \cdot \int_0^\pi [(E_{ON}(I_c) + E_{OFF}(I_c)) \cdot f] dt, \quad (3)$$

where  $f$  is the frequency of PWM;  $E_{ON}(I_c)$  is the energy dissipated in a transistor at en-

abling it, which depends on the magnitude of current in a collector;  $E_{OFF}(I_c)$  is the energy dissipated in a transistor at disabling it, which depends on the magnitude of current in a collector.

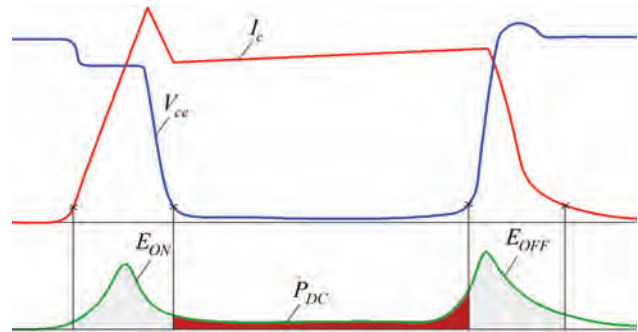

Fig. 3. The process of current and voltage switching in IGBT-switch

Application of the three-level topology of the active rectifier makes it possible to use switches of a lower class to implement the same voltage in a DC circle. In this case, a characteristic feature of switches of a lower class is a smaller drop between the collector and emitter, as well as lower energy for switching [16, 17].

Characteristics of IGBT transistors of different classes, calculated for the same current, are given in Table 1.

The volt-ampere characteristics for transistors  $V_{ce}(I_c)$ , as well as the dependences of switching energy on switching current  $E_{ON}(I_c)$  and  $E_{OFF}(I_c)$  for the IGBT-transistors described in Table 1 are shown in Fig. 4.

Table 1

Characteristics of IGBT transistors of different classes

Type	Current, A	Voltage, V	$V_{ce}$ , V	$E_{ON}$ , J/pulse	$E_{OFF}$ , J/pulse	Price, USD
CM750HG-130R	750	6,600	3.8 (at 25 °C)	3.5 (at 25 °C)	3.4 (at 25 °C)	929
			4.8 (at 125 °C)	4.4 (at 125 °C)	4.9 (at 125 °C)	
CM800HC-90R	800	4,500	3.5 (at 25 °C)	3.1 (at 25 °C)	2.15 (at 25 °C)	714
			4.5 (at 125 °C)	3.8 (at 125 °C)	2.85 (at 125 °C)	
CM800HC-66H	800	3,300	3.3 (at 25 °C)	1.4 (at 25 °C)	2.15 (at 25 °C)	450
			3.6 (at 125 °C)	1.7 (at 125 °C)	2.85 (at 125 °C)	
CM800HB-50H	800	2,500	2.8 (at 25 °C)	0.65 (at 25 °C)	0.75 (at 25 °C)	397
			3.15 (at 125 °C)	0.80 (at 125 °C)	0.96 (at 125 °C)	
CM800HA-34H	800	1,700	2.75 (at 25 °C)	0.3 (at 25 °C)	0.3 (at 25 °C)	285
			3.15 (at 125 °C)	0.37 (at 125 °C)	0.39 (at 125 °C)	
CM800DX-24T1	800	1,200	1.9 (at 25 °C)	0.08 (at 25 °C)	0.084 (at 25 °C)	105
			2.15 (at 125 °C)	0.1 (at 125 °C)	0.11 (at 125 °C)	

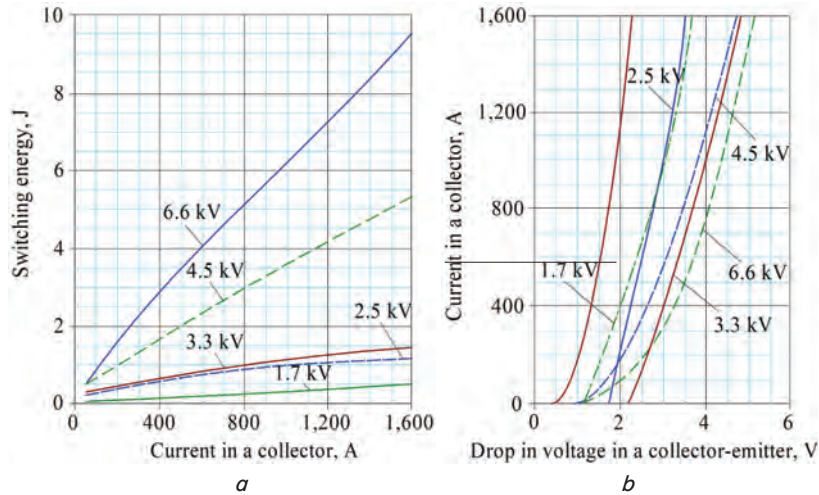

Fig. 4. Characteristics of IGBT-transistors: *a* – dependence of switching energy of IGBT of different classes on current; *b* – dependence of voltage drop in a collector-emitter on current

The dependences shown in Fig. 4 demonstrate that at the same switching frequency and at the same current of load the switches of a twice lower class have much smaller losses for switching.

Numerical calculation of power losses in high-voltage high-power IGBT-transistors included in the two-level and three-level inverters of voltage was conducted using the specialized software MelcoSim 5.4 developed by Mitsubishi company (Fig. 5). The advantage of this software is taking into consideration the actual characteristics of transistors, claimed by the manufacturer Mitsubishi.

We calculated power losses in a three-level active rectifier for IGBT transistors of class 33, the type of CM800HG-90R, and diodes the type of RM1200DB-66S.

For a two-level active rectifier, we calculated losses for transistors of class 65, the type of CM750HG-130R. The calculation was carried out for the following source data: voltage in a DC circle – 3.3 kV, phase current – 400 A, the type of modulation – sinusoidal PWM.

The results from calculating power losses in the specified IGBT modules for the two-level and three-level active rectifier are shown in Fig. 6.

The dependence of efficiency of the two-level and three-level active rectifier (ignoring losses in the active resistance of conductors) on switching frequency is shown in Fig. 7.

Fig. 6 shows that starting at frequency 700 Hz losses in the three-level topology become lower relative to losses in the two-level topology, while efficiency (Fig. 7) grows, indicating the feasibility of applying a given topology at the specified frequencies.

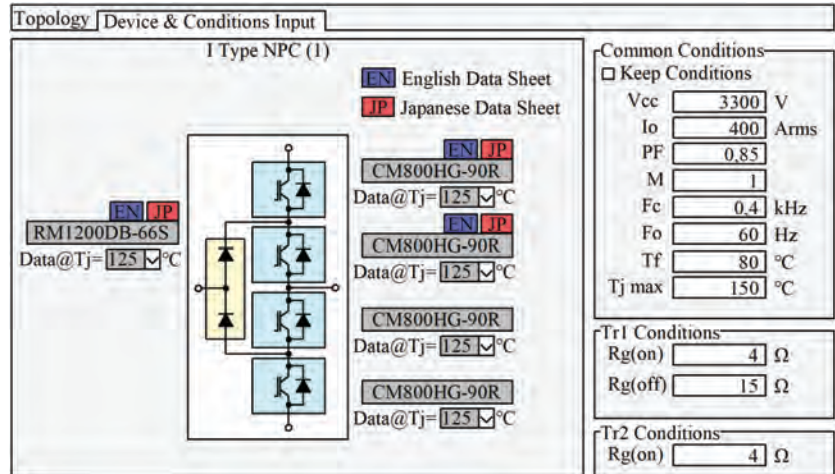

Fig. 5. Interface of software MelcoSim 5.4 when calculating losses in a three-level active rectifier

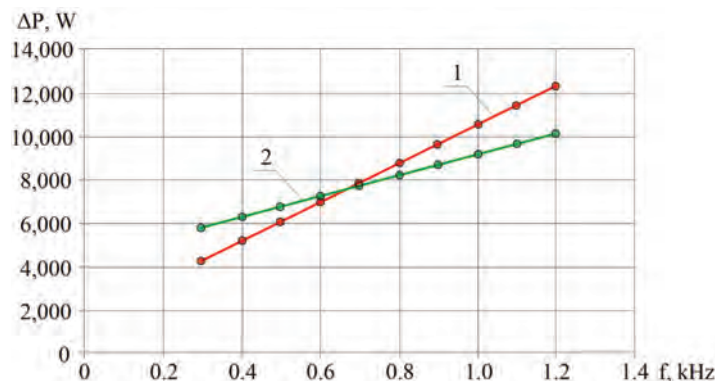

Fig. 6. Dependence of power losses on frequency: 1 – two-level VSI; 2 – three-level VSI

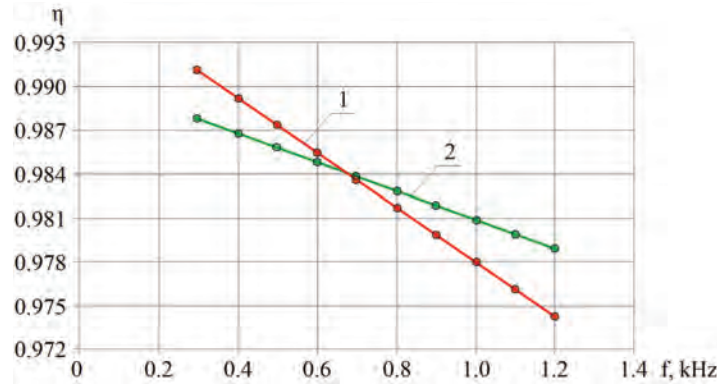

Fig. 7. Dependence of efficiency on switching frequency: 1 – two-level active rectifier; 2 – three-level active rectifier

### 5. Modulation algorithms in three-level active rectifiers

The single-phase three-level active rectifiers, by analogy with the three-level autonomous voltage inverters use the one-channel equal-shifted PWM (Fig. 8).

Feature of such a modulation algorithm is that the input current of a single-phase three-level active rectifier is switched at a reference signal frequency.

We propose using the two-channel equal-shifted pulse width modulation (TES PWM) (Fig. 9).

The essence of the proposed two-level PWM implies the introduction of an additional inverse sinusoidal job signal to the modulation algorithm.

This achieves the following: at the same switching frequency of power switches the frequency of switching the phase current doubles.

That leads to the increased sinusoidality of the current from the power grid.

Increasing the sinusoidality of current leads to decreasing the emission of higher current harmonics.

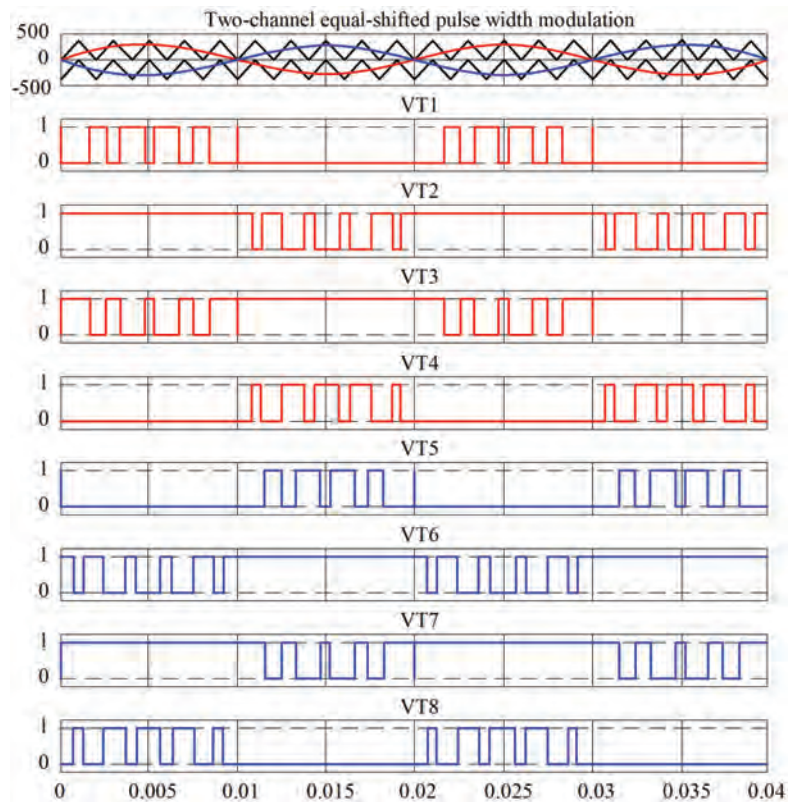

Fig. 9. Two-channel sinusoidal equal-shifted PWM

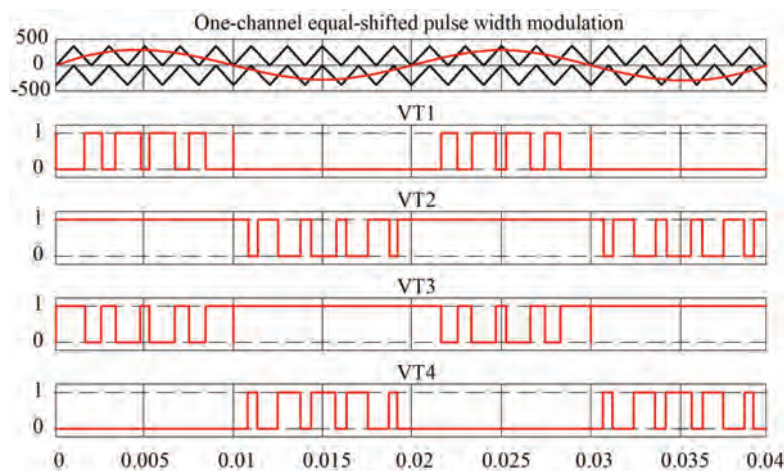

Fig. 8. One-channel sinusoidal equal-shifted PWM

### 6. Simulation modelling

We have developed appropriate simulation models in order to study and compare qualitative indicators for the electromagnetic compatibility of the two-level and three-level active rectifiers with a power grid using the programming environment MATLAB 2017b (Fig. 10).

The parameters of the simulation model are: the amplitude of input voltage – 600 V; inductance of the input reactor – 0.5 mHn, capacity of the output condenser – 24 mF, output voltage – 800 V, power output – 320 kW. The simulation was carried out when solving differential equations that describe the models, using the operator ode23tb, which em-

plies an implicit Runge-Kutta method at the beginning of the solution and the method that subsequently applies the formulae of inverse differentiation of second order. Permissible relative error of calculation is 0.01 %.

An important property of active rectifiers is the possibility of energy recuperation to a power grid. The process of transition by the active three-level active rectifier from a rectification mode to the mode of recuperation is shown in Fig. 11.

Fig. 11 shows that the transition from a rectification mode to a recuperation mode should be performed at the moment of intersecting the instantaneous value for input voltage in the region of zero.

The results from harmonic analysis of the shape of input current in the two-level and three-level active rectifier under a traction mode at switching frequency of IGBT switches 1 kHz are shown in Fig. 12.

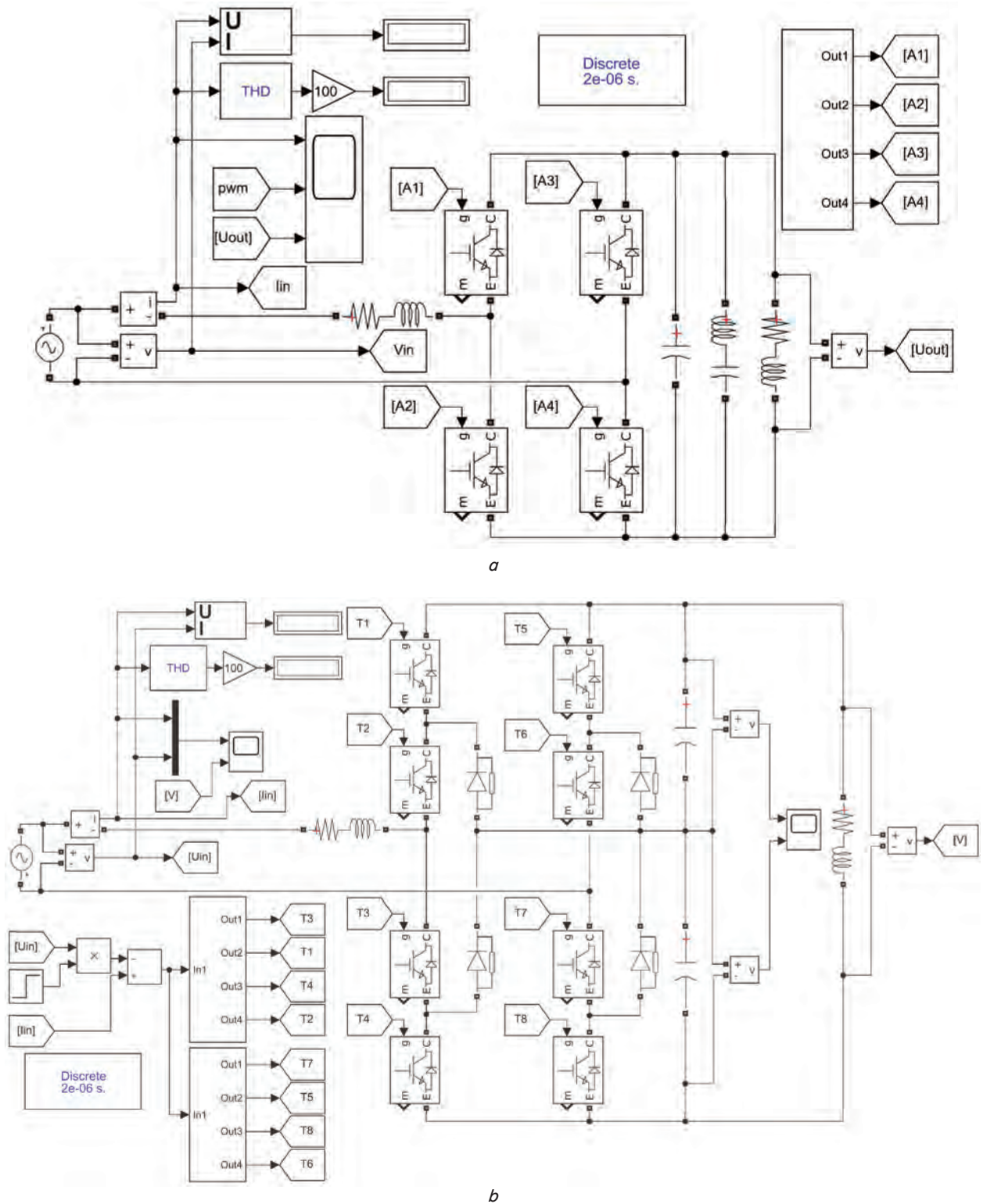

Fig. 10. Simulation models of active rectifiers: *a* – two-level; *b* – three-level

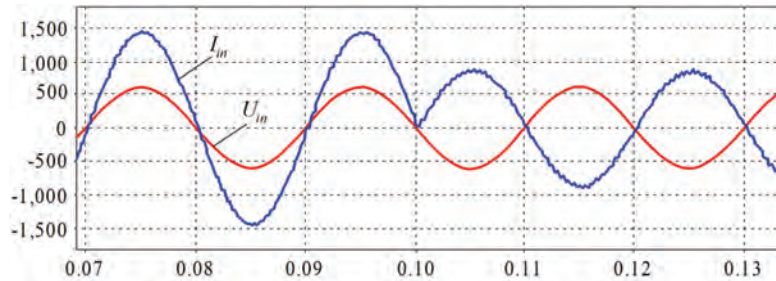

Fig. 11. Oscillograms of the input current and input voltage for a three-level active rectifier in the transition from a rectification mode to a recuperation mode

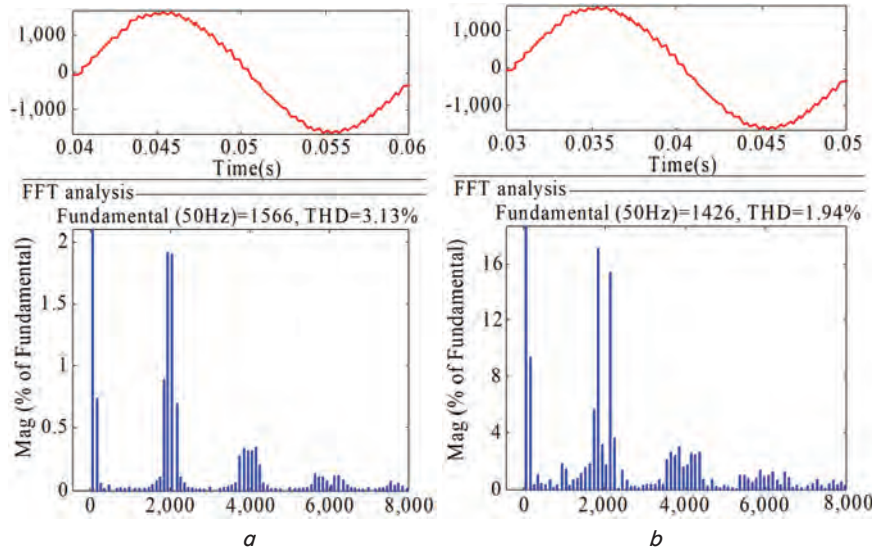

Fig. 12. Simulation results: *a* – two-level active rectifier; *b* – three-level active rectifier

We estimated performance quality of active rectifiers by comparing the values of power factors  $\xi$  and coefficients of total harmonic distortion (THD) for input current. The coefficient of total harmonic distortion of input current is calculated from expression:

$$THD = \frac{I_H}{I_1}, \tag{4}$$

where  $I_H$  is the rms value for the sum of higher current harmonics;  $I_1$  is the rms value for the first current harmonic. The value for  $I_{H\_RMS}$  is determined from expression:

$$I_{H\_RMS} = \sqrt{\sum_{n=2}^{n=m} I_n^2}, \tag{5}$$

where  $m$  is the number of higher harmonics;  $I_n$  is the  $n$ -th higher current harmonic.

Accordingly, the smaller the value for THD, the smaller the content of higher harmonics in current and the lower the additional losses in a network.

The power factor  $\xi$  was calculated from expression:

$$\xi = \frac{P_1}{S} = \frac{U_1 \cdot I_1 \cdot \cos(\alpha)}{U \cdot I}, \tag{6}$$

where  $P_1$  is the rms value for the power of first harmonic;  $U_1$  is the rms value for voltage of the first voltage;  $S$  is the total power.

In the course of simulation, we derived the dependences of values for the coefficients of harmonic values of the input current for the two-level and three-level active rectifier depending on the switching frequency of IGBT, which is shown in Fig. 13.

The derived dependences shown in Fig. 13 demonstrate that over a full range of change in the switching frequency of power transistors the three-level active rectifier implements the improved sinusoidality indicators of the input current and predetermines a lower emission of higher current harmonics.

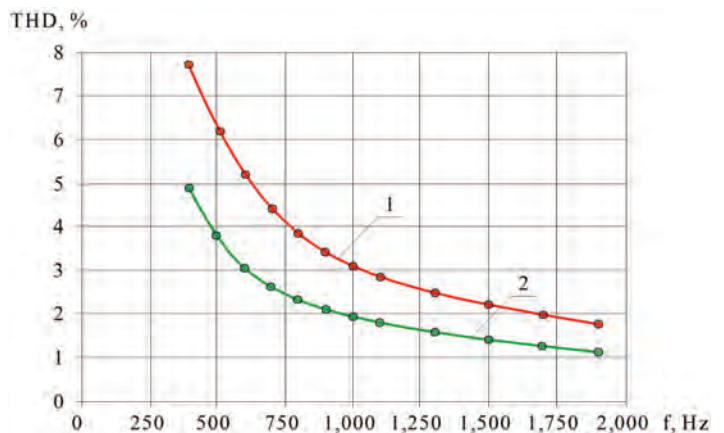

Fig. 13. Dependence of the input current THD in active rectifier on the switching frequency of IGBT switches: 1 – two-level active rectifier; 2 – three-level active rectifier with the two-channel equal-shifted sinusoidal PWM

The obtained energy performance indicators for the two-level and three-level active rectifier at IGBT switching frequency of 1 kHz are given in Table 2.

Table 2

Comparative analysis of performance indicators for the two-level and three-level active rectifier

Indicator	Two-level active rectifier with two-channel PWM	Three-level active rectifier with one-channel PWM	Three-level active rectifier with two-channel PWM
IGBT switching frequency, Hz	1,000	1,000	1,000
Coefficient of harmonic distortions of input current, %	3.13	3.83	1.94
Power factor, %	99.63	99.72	99.77
Coefficient of harmonic distortions of output voltage, %	3.6	5.26	7.2
Efficiency, %	97.8	98.1	98.55

Choosing an actual topology for the active rectifier depends on many factors such as cost, efficiency, and quality indicators of performance, namely the power factor and the harmonic distortion coefficient. In this case, the three-level topology is better in terms of all the above-mentioned parameters, which predetermines the expediency of its application.

### 7. Discussion of results from studying the three-level active rectifier

Our study has proven the feasibility of using, for AC ERS, a circuit of the three-level active rectifier with a control system based on TES PWM. The circuit for the three-level active rectifier, in comparison with the two-level circuit, has a larger efficiency, lower cost of power transistors and predetermines the implementation of a smaller emission of higher harmonics, which is confirmed by calculations and the simulation modelling.

The results obtained are explained by the fact that the circuit for the three-level active rectifier makes it possible to use the IGBT switches at the two-time lower rated voltage, which demonstrate smaller static and dynamic losses.

A special feature of the proposed control system with TES PWM is the possibility to implement the doubling of switching frequency of the input current relative to the clock frequency of PWM. That makes it possible, at the same

power losses in a converter, to obtain the improved quality indicators for the input current.

Certain limitations in the current study are related to the fact that the proposed control system with TES PWM can operate with a modulation coefficient in the range from 0 to 1 and it is not operable under the mode of re-switching.

The disadvantage of our research is that it did not account, during the simulation modelling, for the influence of the pulsed nature of load on the three-level active rectifier. However, subsequent work will take that into consideration.

In order to advance the current research into the three-level active rectifier with TES PWM, it is necessary to construct mathematical models of electromagnetic processes, to synthesize a system of automatic regulation of the output voltage and to study the mode of energy recuperation to a power grid. Upon completion of the theoretical part, it is necessary to build an experimental model of the sample converter.

### 8. Conclusions

1. We have performed a comparative analysis of static and dynamic power losses in the two-level and three-level active rectifier when using the transistors CM800HG-90R (class 33 for the three-level structure) and the transistor CM750HG-130R (class 65 for the two-level structure) manufactured by Mitsubishi. It has been shown that the application of the three-level active rectifier is advisable when implementing the switching frequency above 700 Hz. In this case, the advantage is in obtaining a higher value for efficiency and a smaller value for the content of higher input current harmonics. Our analysis of the cost of power switches has revealed that the circuit for a three-level active rectifier costs less.

2. For the three-level active rectifier, we have proposed the two-channel equal-shifted sinusoidal PWM, which makes it possible, at the same switching frequency of power switches, to ensure the doubling of frequency switching of the input current, which helps achieve the improvement in its sinusoidality.

3. For the two-level and three-level active rectifier, we have established the following energy dependences:

- dependence of the input current THD on switching frequency of IGBT switches;
- the dependence of efficiency on the switching frequency of IGBT switches.

Thus, our study makes it possible to draw a conclusion on that using the circuit for the three-level active rectifier with a control system based on the two-channel equal-shifted sinusoidal PWM is technically and economically justified.

### References

1. Plakhtii, O., Nerubatskyi, V., Ryshchenko, I., Zinchenko, O., Tykhonravov, S., Hordiienko, D. (2019). Determining additional power losses in the electricity supply systems due to current's higher harmonics. *Eastern-European Journal of Enterprise Technologies*, 1 (8 (97)), 6–13. doi: <https://doi.org/10.15587/1729-4061.2019.155672>
2. Zhezhelenko, I. V. (2010). *Vysshie garmoniki v sistemah elektrosnabzheniya promyshlennyh predpriyatiy*. Moscow: Energoatomizdat, 375.
3. Lyutarevich, A. G., Vyrva, A. A., Dolinger, S. Yu., Osipov, D. S., Chetverik, I. N. (2009). Estimation of additional power losses due to higher harmonics in elements of power system. *Omskiy nauchnyy vestnik*, 1, 109–113.
4. Zhezhelenko, I. V., Shidlovskiy, A. K., Pivnyak, G. G. (2012). *Elektromagnitnaya sovместimost' potrebiteley*. Moscow: Mashinostroenie, 351.



5. Bader, M. P. (2014). The analysis and the synthesis of the electromagnetic compatibility of the traction power supply system and infrastructure in the districts with the high-speed traffic. *Elektryfikatsiya transportu*, 7, 78–83.
6. Nerubatskyi, V. P., Plakhtiy, A. A., Gladka, A. V. (2018). EMC improvement research of three-phase active rectifiers with power factor correction in regenerative mode. *Collected scientific works of Ukrainian State University of Railway Transport*, 178, 21–28. doi: <https://doi.org/10.18664/1994-7852.178.2018.138906>
7. Blahnik, V., Talla, J. (2016). Single-phase synchronization for traction active rectifier. *2016 International Conference on Applied Electronics (AE)*. doi: <https://doi.org/10.1109/ae.2016.7577233>
8. Scherback, Y. V., Plakhtiy, O. A., Nerubatskyi, V. P. (2017). Control characteristics of active four-quadrant converter in rectifier and recovery mode. *Tekhnichna Elektrodynamika*, 2017 (6), 26–31. doi: <https://doi.org/10.15407/techned2017.06.026>
9. Fomin, O. V., Lovska, A. O., Plakhtii, O. A., Nerubatskyi, V. P. (2017). The influence of implementation of circular pipes in load-bearing structures of bodies of freight cars on their physico-mechanical properties. *Scientific bulletin of National mining university*, 6, 89–96.
10. Kolmakov, N. M., Bahovtsev, I. A., Garganeev, A. G. (2016). Analiz gisterezisnogo upravleniya po napryazheniyu avtonomnogo invertora napryazheniya. *Doklady Tomskogo gosudarstvennogo universiteta sistem upravleniya i radioelektroniki*, 19 (2), 84–89.
11. Yakupov, D. V., Kazachkovskiy, N. N. (2010). Control principles for PWM-based active rectifier under perturbations from the load. *Vestnik KDU imeni Mihaila Ostrogradskogo*, 4 (63), 16–19.
12. Oleksandr, P., Volodymyr, N. (2018). Analyses of Energy Efficiency of Interleaving in Active Voltage-Source Rectifier. *2018 IEEE 3rd International Conference on Intelligent Energy and Power Systems (IEPS)*. doi: <https://doi.org/10.1109/ieps.2018.8559514>
13. Gervasio, F., Mastromauro, R. A., Liserre, M. (2015). Power losses analysis of two-levels and three-levels PWM inverters handling reactive power. *2015 IEEE International Conference on Industrial Technology (ICIT)*. doi: <https://doi.org/10.1109/icit.2015.7125248>
14. Zhao, L., Wang, Q., Li, G., Chen, Q., Hu, C. (2014). Analyze and compare the efficiency of two-level and three-level inverter in SVPWM. *2014 9th IEEE Conference on Industrial Electronics and Applications*. doi: <https://doi.org/10.1109/iciea.2014.6931488>
15. Vintrih, A., Ul'rih, N., Kolpakov, A. I., Mysak, T. V., Polischuk, S. I. (2017). Analiz dinamicheskikh poter' moschnyh IGBT. *Vestnik Natsional'nogo tekhnicheskogo universiteta «Kharkivskiy politekhnicheskii institut»*, 27, 191–196.
16. Wu, R., Wen, J., Wu, J., Chen, Z., Peng, C., Wang, Y. (2012). Analysis of power losses in voltage source converter with new generation IGBTs. *2012 IEEE International Conference on Computer Science and Automation Engineering (CSAE)*. doi: <https://doi.org/10.1109/csae.2012.6272683>
17. Dai, P., Guo, G., Gong, Z. (2016). A Selection Precharge Method for Modular Multilevel Converter. *International Journal of Control and Automation*, 9 (4), 161–170. doi: <https://doi.org/10.14257/ijca.2016.9.4.16>