

УДК 629.341
UDC 629.341

FINITE ELEMENT ANALYSIS OF DEEP DRAWING OF DDQ AUTO-BODY STEEL SHEET

TRZEPIECINSKI Tomasz, DSc. PhD. Eng., Rzeszow University of Technology, Rzeszow, Poland

АНАЛІЗ ГЛИБОКОЇ ВИТЯЖКИ СТАЛЕВОГО ЛИСТА DDQ AUTO-BODY МЕТОДОМ КІНЦЕВИХ ЕЛЕМЕНТІВ

ТЖЕПІЦІНСКІ Томаш, Доктор інженер, Жешовська Політехніка, Жешув, Польща

Introduction. The deformation mechanism of rectangular cup drawing is very complicated for a theoretical analysis [3]. On the other hand, conventional design processes for sheet metal forming are usually based on an empirical approach. Today, numerical simulation using FEM approach is widely applied in the attempt to have better understanding of sheet metal forming processes. Among others, application of FEM allows predicting the forming defects and provides knowledge of deformed shape, stress and strain distribution and punch loading. The most important elements of numerical simulation is the friction description and constitutive equation that describes the flow stress as a function of the deformation. Plastic anisotropy is the result of the distortion of the yield surface shape due to the material microstructural state [2]. The anisotropy is of two types: normal and planar anisotropy. In normal anisotropy the properties differ in the thickness direction; in planar anisotropy however the properties vary with the orientation in the plane of the sheet. Whereas drawability of sheets increases with normal anisotropy, planar anisotropy leads to the formation of ears in cup drawing [11].

A friction model is completely defined by the friction condition which specify a set of admissible contact forces and the sliding rule which stipulates what directions of sliding are allowed [8, 9]. The limit surface is usually assumed to be isotropic predicting a frictional behavior independent of the sliding direction. For many industrial applications, this assumption seems to be unrealistic and many experimental studies show that the frictional behavior can change drastically with the sliding direction, requiring an anisotropic model. The origin of this anisotropy can be attributed to two different sources. The first one is the material itself where the anisotropies of the materials constituting the bodies manifest themselves on the contact surface [7]. Currently, there are not so many publications focusing on frictional anisotropy and its implementation in numerical simulations of sheet metal forming processes.

Material and test method. The drawing processes presented in this work were achieved with a form of deep drawing quality (DDQ) cold-rolled steel sheet with a sheet thickness of 1 mm. The mechanical properties of the sheet metal have been determined through tensile tests along three directions with respect to the rolling direction. The elastic behavior is specified in numerical simulations by the value of Young's modulus, $E = 210000$ MPa, and of Poisson's ratio $\nu = 0.3$. The isotropic hardening behavior implemented in FEM model uses the Hollomon power-type law. The parameters in Hollomon equation have been fitted on stress-strain curve of the tensile test.

Different material properties working in different directions can have a significant effect on the degree of difficulty of the forming operation. In particular, textures and orientation of the crystal structure to the rolling direction of the sheet metal lead to anisotropic directional behavior. The anisotropy of plastic behavior of sheet metals is characterized by the Lankford's coefficient r [2], which is determined by uniaxial tensile tests. The r value is defined as the ratio of the true strain ε_2 in width and the true strain ε_3 in the thickness direction of a specimen:

$$r = \frac{\varepsilon_2}{\varepsilon_3} \quad (1)$$

Due to the fact that measuring the longitudinal elongation is easier to perform, the condition of volume constancy $\varepsilon_1 + \varepsilon_2 + \varepsilon_3 = 0$ was assumed. Taking into consideration that $\varepsilon_1 = \ln(l/l_0)$ and $\varepsilon_2 = \ln(b/b_0)$, equation (1) can be rewritten as:

$$r = \ln\left(\frac{l}{l_0}\right) \cdot \left(\ln\left(\frac{l_0 b_0}{l \cdot b}\right)\right)^{-1} \quad (2)$$

where b and l are the measured values of the initial (b_0, l_0) and final (b, l) width and length of the

specimen, respectively.

The mechanical parameters of DDQ steel sheet are presented in Table 1.

Table 1. Mechanical properties of the sheet metals

Orientation	Yield stress [MPa]	Ultimate tensile strength [MPa]	Material constant C [MPa]	Hardening exponent n	Lankford's coefficient r
0°	162	310	554	0.21	1.55
45	163	322	542	0.20	1.27
90°	168	312	530	0.21	1.67

In the experiment, deep drawings of cylindrical flat and square punches were performed by a device consisting of a die, a punch and a blank holder (Fig. 1).

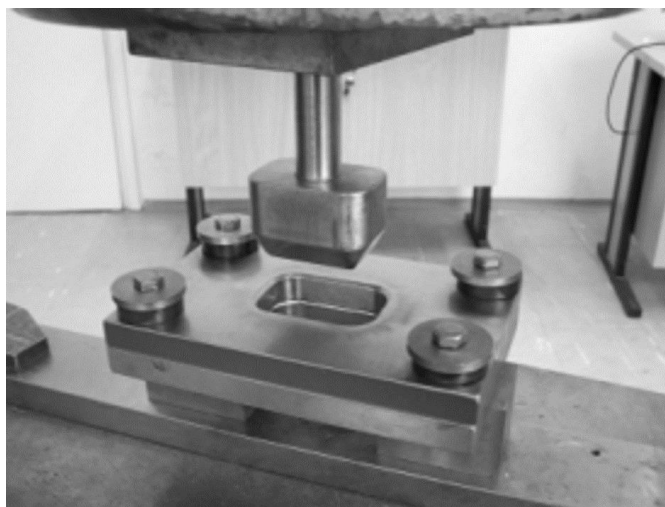

Fig. 1. View of setup in testing machine

The die is a flat surface with a rectangular hole 61.4 mm by 40.4 mm, rounded at the edges with a radius of 3 mm. The rectangular punch with a size 60 mm by 40 mm is chamfered by an angle of 30° and rounded at the edges with the same 12 mm radius. The die set is constructed of cold-worked NC6 tool steel, hardened to a minimum of 58 HRC. The drawing of cups was run in dry friction conditions. The complete drawing apparatus was conducted within the Schenck UTS 100 hydraulic test machine with forming speed of 0.3 mm/s at a room temperature.

Three cups (Fig. 2) with different height corresponding to punch strokes of 7 mm, 11 mm, 16 mm and after full drawing were experimentally carried out. Particular cups were cut along three directions with respect to the rolling direction, transverse, longitudinal and at 45° angle. The distribution of thickness was measured along vertical cross section of the cup formed using a microscope device.

Numerical model. The blank, die and punch were modeled corresponding to the experimental setup. Symmetry of the process was utilized in order to reduce the CPU time, i.e., only one quarter of blank and tool with appropriate boundary conditions were modeled (Fig. 3). The blank was modeled with 4-node reduced integration, doubly curved shell elements, called S4R in ABAQUS terminology [1]. Five integration points through the thickness direction were employed. This shell element type is intentionally applied for analysis of sheet metal forming processes [6], and this element accounts for the change of thickness in its output variables, unlike solid and plane strain elements. As the tools were considered to be rigid, no deformation was assumed in these parts during forming the process. The blank model is composed of 3103 4-node elements. The tools were consisted of 9586 linear quadrilateral elements. To prevent wrinkling, uniform blank holder force of 7850 N corresponding to the experiment was applied on the top surface of a blank holder plate. The boundary conditions applied to the blank holder allow displacement in the normal direction to the blank surface so that the wrinkling formation was prevented and the frictional resistance in flange region was minimized.

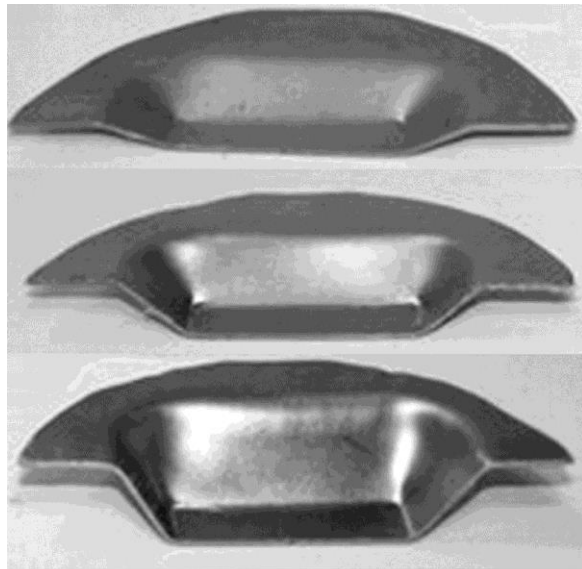

Fig. 2. Cup sections correspond to punch strokes 7, 11 and 16 mm

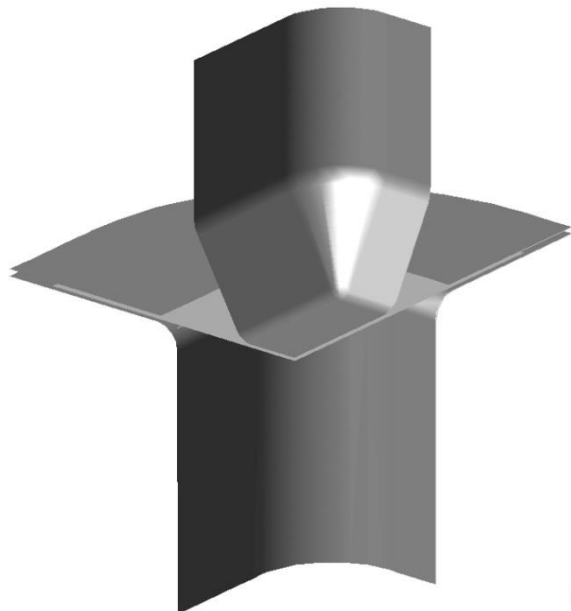

Fig. 3. Schematic illustration of the tools and blank for the FEM model

Numerical simulations were performed with material behavior described by von Mises [12] yield criterion with isotropic hardening and with anisotropic yield condition described by Hill [4]. For ideal case of isotropic materials, von Mises [12] yield condition is expressed as:

$$f = J(\tau - X) - R(p) = 0 \quad (3)$$

where $J(\tau - X)$ is the second invariant of the deviatoric stress; τ and X are second order tensors indicating the deviatoric component of the Cauchy stress and the translation of the yield surface, respectively; and p is a scalar proportional to the effective plastic strain or the plastic work.

As mentioned previously, Hill's [4] formulation is the most frequently used yield function for steel sheet metals. It can be regarded as an extension of the isotropic von Mises function, which can be expressed in terms of rectangular Cartesian stress components as follows:

$$\bar{\sigma} = \sqrt{F(\sigma_{22} - \sigma_{33})^2 + G(\sigma_{33} - \sigma_{11})^2 + H(\sigma_{11} - \sigma_{22})^2 + 2L\sigma_{23}^2 + 2M\sigma_{31}^2 + 2N\sigma_{12}^2} \quad (4)$$

where $\bar{\sigma}$ is the equivalent stress, and indices 1, 2, 3 represent the rolling, transverse and normal direction to the sheet surface. Constants F, G, H, L, M and N defined anisotropy state of material and the method of their determining was shown e.g. in [5].

The friction properties of the deep drawing quality steel sheets used in the experiments were determined by using the pin-on-disc tribometer T01-M. The values of friction coefficient were determined in dry friction conditions. To confirm that steel sheets are characterized by the anisotropy of tribological properties, friction anisotropy on a given surface has to be clearly distinguished from friction anisotropy for different perpendicular orientations between the pin and the surface. As shown in Fig. 3, changes of friction coefficient value exhibit two maxima for a rotation through 360°. They correspond to the measurement of friction coefficient value transverse to the rolling direction.

The anisotropic friction model was implemented by specifying different friction coefficients in two orthogonal directions on the contact surface. These orthogonal directions coincide with the defined slip directions. To use an anisotropic friction model two friction coefficients ($\mu_1 = 0.142$ and $\mu_2 = 0.157$) were specified, where the first is the coefficient of friction in the first slip direction along the rolling direction and second is the coefficient of friction in the perpendicular slip direction. For simulation models with isotropic friction an average friction coefficient value of 0.1495 was received.

The critical shear stress surface in anisotropic friction model is defined by a piece of ellipse defined by Eq. (5):

$$\tau_1 = \tau_1^{max} \cos \alpha, \tau_2 = \tau_2^{max} \sin \alpha, \text{ where } \alpha \in \left\langle 0, \frac{\pi}{2} \right\rangle \quad (5)$$

where α is the angle between the sliding direction and the direction of sheet rolling. This elliptic surface defined by Eq. (3) has two extreme points given by $\tau_1^{crit} = \mu_1 P$ and $\tau_2^{crit} = \mu_2 P$.

Results and discussion. In order to investigate the variations in the wall thicknesses of rectangular cups, several experiments were carried out through gradual increment of the punch displacement. While forming at each grade, thickness distribution was separately investigated. The formation process of the conical wall of the drawpiece satisfied a condition of free stretching of the drawpiece side-wall. Although bending tensions occur on the plate with the first contact of the punch on the sheet plate, these tensions transform into drawing and pressing tensions while moving the punch towards the deeper sections. Furthermore, friction forces appear due to the contact of the sheet plate with the punch and die, and only drawing and bending tensions occur at sections with no contact. With the penetration of the punch into the die, only drawing tensions play an active role at sections of the sheet plate that remains within the die. Verification of numerical results in characteristic sections was then carried out on the basis of the measurements of wall thickness of the drawpieces. Parts formed to examine the thickness changes after the stamping experiments were cut along the rolling and transverse directions starting from the centre of the part. Furthermore, the cups were cut in the corner at an angle of 45° with respect to the rolling direction (Fig. 4).

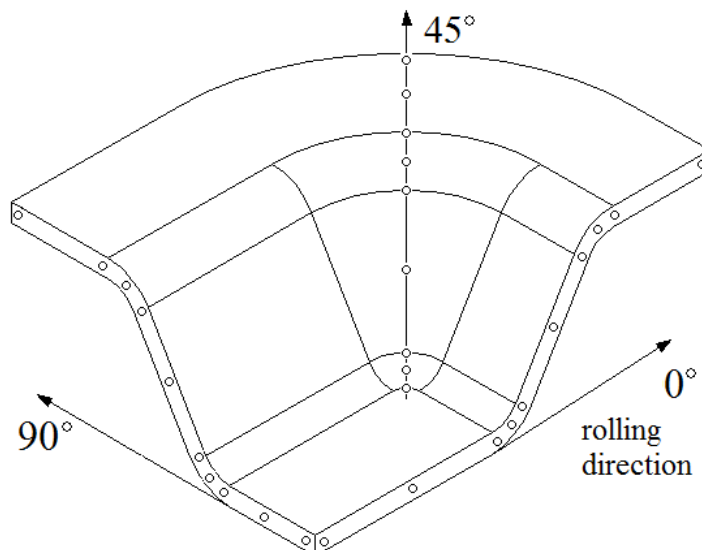

Fig. 4. Scheme of measurement points of wall thickness

The cut sides are trimmed and the changes of thickness were measured by using an optical microscope. The measurement in rolling and transverse directions does not cause difficulties because the nodes under the whole forming process are in the symmetry plane. Besides rectangular shape of the punch and non-axisymmetrical shape of the blank material, the friction anisotropy caused position changes of the nodes in corner cup relative to the perpendicular plane of the blank and inclined angle of 45° with respect to the rolling direction.

The thickness strain distributions along 0° , 45° and 90° directions referred to the rolling direction are shown in Fig. 5. Three deformed profiles determined for true distance along each path were compared with experimental measurements. As expected, the thickness strain distributions are different along these directions for all punch displacements. The decisive impact on this character exerts the non-axisymmetrical shape of parts. The thickness distribution of the sheet under the punch is found to be more or less uniform to the initial sheet thickness. However, the thickness of the sheet, which was above the flat portion of the die, is observed to be slightly larger than the initial thickness. The thickness measured in the rolling direction (the long side) is smaller than that from the transverse direction (the short side) near the punch shoulder. The main reason for this effect is the unsymmetrical shape of the process, where a higher fraction of radial tension stress exists along the short wall of the rectangular drawpiece along the long side wall. Other studies [10] also show that the short side wall of the rectangular drawpiece near the punch edge is the most expose to the fracture.

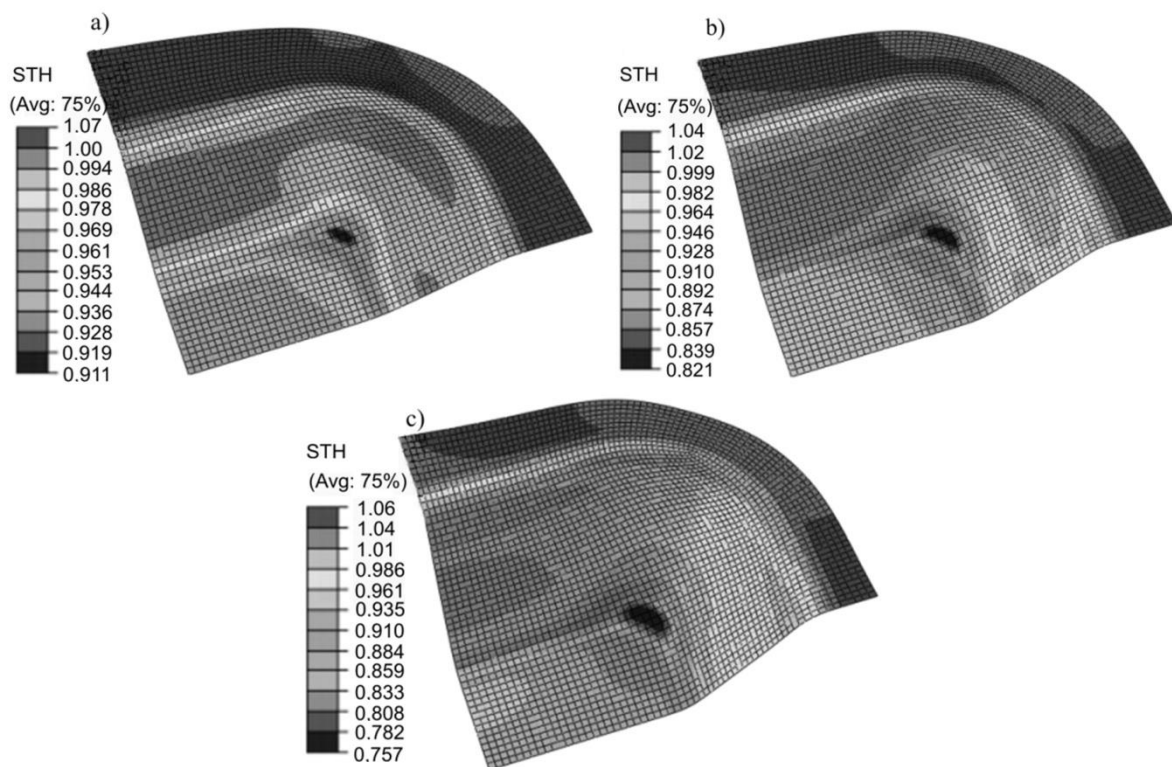

Fig. 5. Contour of the sheet thickness (Hill material model + anisotropic friction) under punch displacement of : a) 7 mm, b) 11 mm and c) 16 mm

The distributions of wall thickness measured and calculated at the end of drawing on the symmetrical lines of long and short sides and the diagonal line passing through the corner, are shown in Fig. 6. The differences of the results obtained from analyzed anisotropy strategies can be seen clearly from the thickness contours of some models. The good predictive capability of the proposed Hill anisotropy model plus anisotropic friction (AF) has been demonstrated. The maximum wall thickness in all directions is observed near the edge of blank, while the minimum thickness is at the punch shoulder. Compared with deformation on the corner, the variation of thickness at bottom of drawpiece is relatively small. Replacement of anisotropy friction model by isotropic friction (IF) model in both models of material causes slight decrease in thickness. It is also clearly visible that the character of the thickness variation is similar at the bottom of drawpiece. In other parts of drawpiece this phenomenon is more complicated.

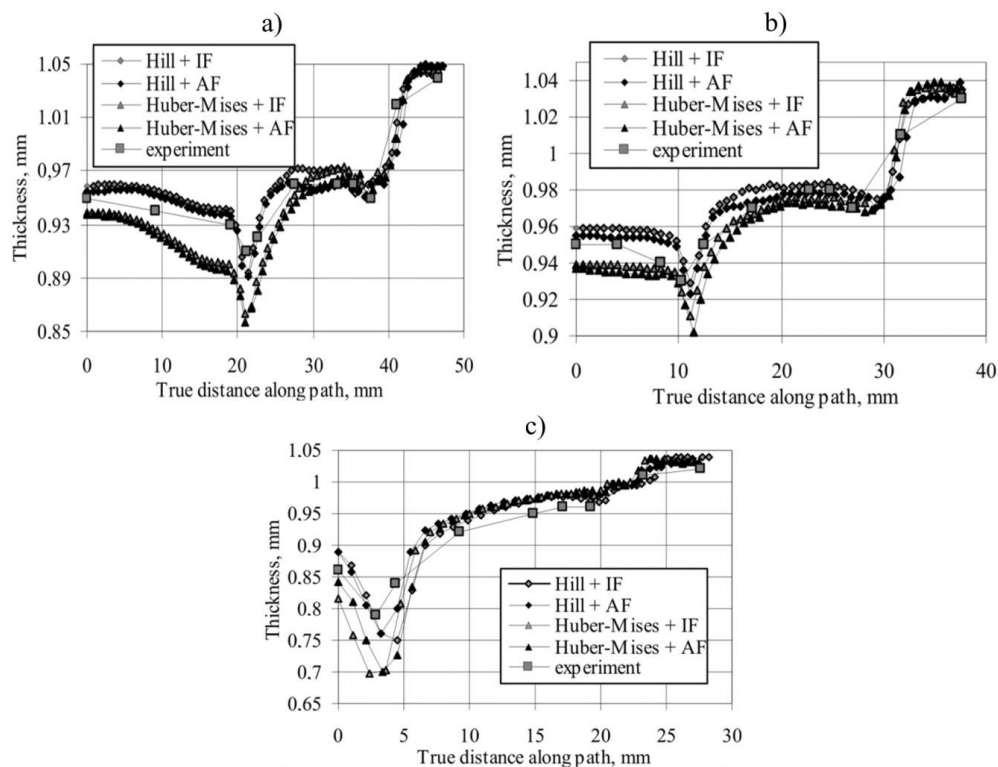

Fig. 6. Plot of the thickness strain under the punch displacement of 16 mm measured in the rolling direction (a), transverse to the rolling direction (b), and at an angle of 45° with respect to the rolling direction (c)

Conclusions. This study has attempted to investigate the anisotropy problem in sheet metal drawing using both experimental and numerical approach. Hill's yield criterion was implemented in the material description of the numerical model. Together with friction anisotropy condition, this model gave simulation results that can better approximate the experimental measurements. It is considered that distribution of wall thicknesses obtained by means of experiments and FEM includes material and friction anisotropy generally demonstrates a great harmony, and that minor differences are due to the fact that conditions in the finite elements method are considered ideal. Although the simulated thickness in the flange area along all directions is slightly overestimated, the agreement between predicted and experimental thickness distributions is generally excellent. Consideration of the anisotropy of resistance to friction slightly influences the numerical results on variation of the thickness and strain distribution compared with isotropic friction model. All in all, this investigation has demonstrated that application of FEM method for optimization of initial blank shape is an attractive approach which eliminates time-consuming experimental methods.

REFERENCES

- [1] ABAQUS version 6.7 - Theory Manual. Hibbit, Karlsson & Sorenson, Dassault Syst`emes, Providence 2007.
- [2] Banabic D., Bunge H.-J., Pohlandt K., Tekkaya A.E.: Formability of metallic materials. Springer-Verlag, Heidelberg 2000.
- [3] Daxin E., Takaji M., Zhiguo L.: Stress analysis of rectangular cup drawing. Journal of Materials Processing Technology, 205, 2005, 469-475.
- [4] Hill R.: A theory of the yielding and plastic flow of anisotropic metals. Proceedings of the Royal Society of London, 193, 1948, 281-297.
- [5] Hjjaj M., Feng Z.-Q., de Saxc G., Mróz Z.: On the modelling of complex anisotropic frictional contact laws. International Journal of Engineering Science, 42, 2004, 1013-1034.
- [6] Ragai I., Lazim D., Nemes J.A.: Anisotropy and springback in draw-bending of stainless steel 410: experimental and numerical study. Journal of Materials Processing Technology, 166, 2005, 116-127.
- [7] Trzepieciński T.: 3D elasto - plastic FEM analysis of the sheet drawing of anisotropic steel sheet metals. Archives of Civil and Mechanical Engineering, 10, 2010, 95-106.
- [8] Trzepieciński T.: Analysis of the friction influence on change of surface topography in strip

drawing test. Tribologia, 44, 2012, 125-134.

[9] Trzepieciński T.: Badanie właściwości tarciovych blach stalowych dla przemysłu motoryzacyjnego. Hutnik Wiadomości Hutnicze, 81, 2014, 446-449.

[10] Trzepieciński, T., Stachowicz, F.: Modelowanie numeryczne procesu kształtowania wytloczek prostokątnych. Rudy Metale Nieżelazne, 50, 2005, 582-585.

[11] Van Houutte P.: Anisotropic plasticity, [in:] Hartley P., Pillingar I., Sturgess C. (eds.), Numerical modeling of material deformation process: research, development and applications, Springer-Verlag, London 1992, pp. 84-111.

[12] Von-Mises R., Mechanik der festen Körper im plastisch deformablen Zustand. Nachrichten von der Gesellschaft der Wissenschaften zu Göttingen, Mathematisch-Physikalische Klasse, 1913, pp. 582-592.

ABSTRACT

TRZEPIECINSKI Tomasz. Finite element analysis of deep drawing of ddq auto-body steel sheet. Visnyk National Transport University. Series “Technical sciences”. Scientific and Technical Collection. - Kyiv. National Transport University, 2015. - Issue 2 (32).

This paper presents the experimental and numerical results of rectangular cup drawing of steel sheets. The aim of the experimental study was to analyze material behavior under deformation. A 3D parametric finite element (FE) model was built using the commercial FE-package ABAQUS. A quadratic Hill anisotropic yield criterion was compared with von Mises yield criterion having isotropic hardening. The sensitivity of constitutive laws to the initial data characterizing material behavior is also presented. If the material and friction anisotropy are taken into account in the finite element analysis, this approach undoubtedly gives the most approximate numerical results to real processes.

РЕФЕРАТ

ТЖЕПІЦІНСЬКИЙ Томаш. Аналіз глибокої витяжки сталевих листів ddq auto-body методом кінцевих елементів / Вісник Національного транспортного університету. Серія “Технічні науки”. Науково-технічний збірник. – К.: НТУ, 2015. - Вип. 2 (32).

В статті наведено експериментальні та чисельні результати прямокутної чашки креслення сталевих листів. Метою експериментального дослідження було проаналізувати поведінку матеріалу при деформації. 3D-параметрична модель кінцевих елементів (FE) була побудована з використанням комерційного FE-паketу ABAQUS. Квадратичний Хілл критерій анізотропної плинності був порівняний з критерієм плинності Мізеса, що є ізотропним. Чутливість залежностей у початковий момент, що характеризують поведінку матеріалу також представлені. Якщо матеріал і тертя анізотропії беруться до уваги при аналізі методом кінцевих елементів, цей підхід, безсумнівно, дає найбільш наближені чисельні результати реальних процесів.

AUTHORS:

TRZEPIECINSKI Tomasz, DSc. PhD. Eng, Rzeszow University of Technology, Department of Materials Forming and Processing, Warsaw Insurgents Boulevard 12, tel.: +48 17 865 1100, 35-959, Rzeszow, Poland

АВТОРИ:

ТЖЕПІЦІНСЬКИЙ Томаш, Доктор габілітований, Жешовська Політехніка, Кафедра формування і обробки матеріалів, Бульвар Повстанців Варшави 12, tel.: +48 17 865 1100,35-59,Жешув, Польща

AUTORZY:

TRZEPIECIŃSKI Tomasz, Dr hab. inż., Politechnika Rzeszowska, Katedra Przeróbki Plastycznej, Al. Powstańców Warszawy 12, tel.: +48 17 865 1100,35-959,Rzeszów, Polska

РЕЦЕНЗЕНТИ:

Посвятенко Е.К., доктор технічних наук, професор, Національний Транспортний Університет, професор кафедри виробництва, ремонту та матеріалознавства, Київ, Україна.

Сахно В.П., доктор технічних наук, професор, Національний Транспортний Університет, завідувач кафедри автомобілів, Київ, Україна.

REVIEWERS:

Posvyatenko E.K., Doctor of Technical Sciences, Professor, National Transport University, Professor of Department of Manufacturing, Repair and Materials Engineering, Kyiv, Ukraine.

Sakhno V.P, Doctor of Technical Sciences, Professor, National Transport University, Head of Department of Automobile, Kyiv, Ukraine.