

*Maliovana O.O., post-graduate
ORCID 0000-0003-3740-3228 alenka_malecha@mail.ru
Poltava National Technical Yuri Kondratyuk University*

STRENGTH OF HIGHER STRENGTH CONCRETE ELEMENTS UNDER SHEAR ACTION

The strength design method of concrete and reinforced concrete elements is expounded in this article. The experimental program included the study of the strain condition and failure load determination for considered types of elements. The strength design method is expounded for concrete and reinforced concrete elements by means of variation method in the concrete plasticity theory that was developed in Poltava National Technical Yuri Kondratyuk University. There are the results of experimental investigation for truncated concrete wedges that simulate work of concrete compressed zone above dangerous inclined crack, Hvozdev specimens and crucial keys as well as beams. Also all elements were made of higher strength concrete in order to test the applicability of given method to these elements. The results of the experimental research have confirmed the applicability of plasticity zones assumed in the theoretical solutions. The theoretical strength is well coordinated with the experimental one. The failure character of reinforced concrete beams has been discovered. It has not differed from the flexure elements failure by cross section made of conventional concrete.

Keywords: *shear action, variation method, truncated wedge, Hvozdev specimen, key, beam, higher strength concrete.*

*Мальована О.О., аспірант
Полтавський національний технічний університет імені Юрія Кондратюка*

МІЦНІСТЬ ЕЛЕМЕНТІВ ІЗ БЕТОНУ ПІДВИЩЕНОЇ МІЦНОСТІ ПРИ ЗРІЗІ

Викладено методику розрахунку міцності бетонних і залізобетонних елементів, котрі перебувають під дією зрізувальних сил, а також програму експериментів, яка містить дослідження деформованого стану та визначення граничного навантаження зазначених типів елементів. Застосовано методику розрахунку, котра базується на варіаційному методі у теорії пластичності бетону, розробленому в ПолтНТУ. Отримано результати експериментального дослідження зрізаних бетонних клинів, які моделюють роботу стиснутої зони бетону над небезпечною похилою тріщиною, зразків Гвоздева та залізобетонних шпонок, а також залізобетонних балок на дію поперечної сили. Дослідні зразки було виготовлено з бетону підвищеної міцності для з'ясування можливості застосування запропонованого методу до розрахунку їх міцності. Виконано порівняльний розрахунок теоретичної міцності з дослідною, котрий показав їх достатню близькість. Виявлено характер руйнування досліджуваних балок, який принципово не відрізняється від руйнування згинальних елементів за похилим перерізом із бетонів середньої міцності.

Ключові слова: *зрізувальні сили, варіаційний метод, зрізаний клин, зразок Гвоздева, шпонка, балка, бетон підвищеної міцності.*

Introduction. Concrete and reinforced concrete elements under the action of shear forces are important and widely used in the practice of construction. The mentioned elements include the beams and slabs, short elements, monolithic massive constructions. They all differ from each other in the construction determination, dimensions, forms and the character of stress-strain state in the shear plane.

Traditional heavy concrete has been replaced by multi-component modified concrete that differs by high strength and corrosion durability, water resistance and freeze-thaw durability. At the same time it characterizes by higher brittle behavior that makes condition for its homogeneous structure.

Analysis of the latest researches and publications. Data concerning main characteristics of high strength concrete made by traditional technology using high mark cement and precise selection of components are given in works of O. Ya. Berg [1], O. Ye. Desov [2], V. I. Sytnyk [3] and others.

Main concepts of high strength concrete development based on high-range water-reducers are observed by V. H. Batrakov [4], S. S. Kaprielov [5], A. V. Korsun [6] and others.

Experimental investigation of deformation and strength characteristics of high strength concrete in Ukraine almost did not go beyond testing small specimens (mainly prisms). Therefore, a comprehensive analysis of the characteristics of high-strength concrete can be done only after testing full-scale structural elements and nodes of their connection. Such investigations are famous abroad [7–11], as well as were carried out in PoltNTU [12–14].

Emphasis of not determined earlier parts of general requirements. Usage of design method which is based on concrete plasticity theory for elements with higher embrittlement raises some questions.

The action of DBN B.2.6-98:2009 is being distributed on the traditional concrete and the development of the normative document «Concrete and reinforced concrete constructions of high-strength concrete (concrete class for compression higher than C 50/60)» is being only envisaged. So, there is a problem of strength design of high-strength concrete elements.

Variation method in the concrete plasticity theory for concrete and reinforced concrete elements was developed in Poltava National Technical Yuri Kondratyuk University [15]. It can be referred to the engineer design methods that bring to really easy relations, don't need an involvement of the complex computer programs and found wide distribution in the design practice. The method is widely tested by strength design of reinforced concrete constructions under shear action using heavy and lightweight concrete [16].

Objective of the work is the attempt to expand the variation method on the strength design of high strength concrete elements by shear.

Summary of main information. Two famous technologies of getting high strength concrete were used by author during conducting experimental investigation. Traditional one is based on high mark cement and precise selection of components. The second one is based on complex application of high-range water-reducer and silica fume.

Following elements were considered as the experimental models: truncated concrete wedges that simulate work of concrete compressed zone above dangerous inclined crack, Hvozdev specimens and crucial keys as well as beams.

Truncated concrete wedges were made of concrete with addition of silica fume and high-range water-reducer [17]. Two series of specimens were tested. The first one consisted of 5 wedges where angle α was constant and equaled to 30° . Angle β with constant α varied in next sequence: -20° (V_c directed to square corner), 10° , 0° , 5° , 20° . The second series included 3 specimens with following parameters: with angle $\alpha = 45^\circ$ angle β was 20° and 30° , and with $\alpha = 15^\circ - \beta = 10^\circ$. The height of compressed zone was $h_w \approx 50$ mm for all specimens and the wedge thickness was $b_w \approx 150$ mm. Low parts of specimens were reinforced for failure prevention.

The concrete deformations of wedges were measured by strain gages that were placed in some distance from the wedge top (fig. 1).

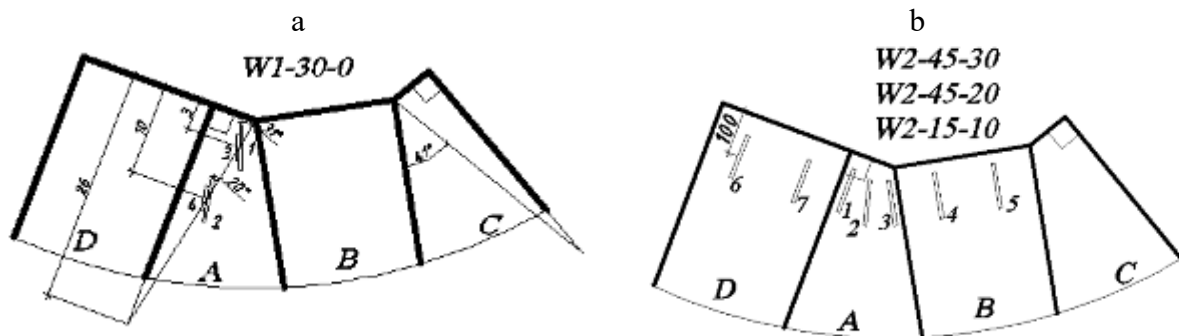
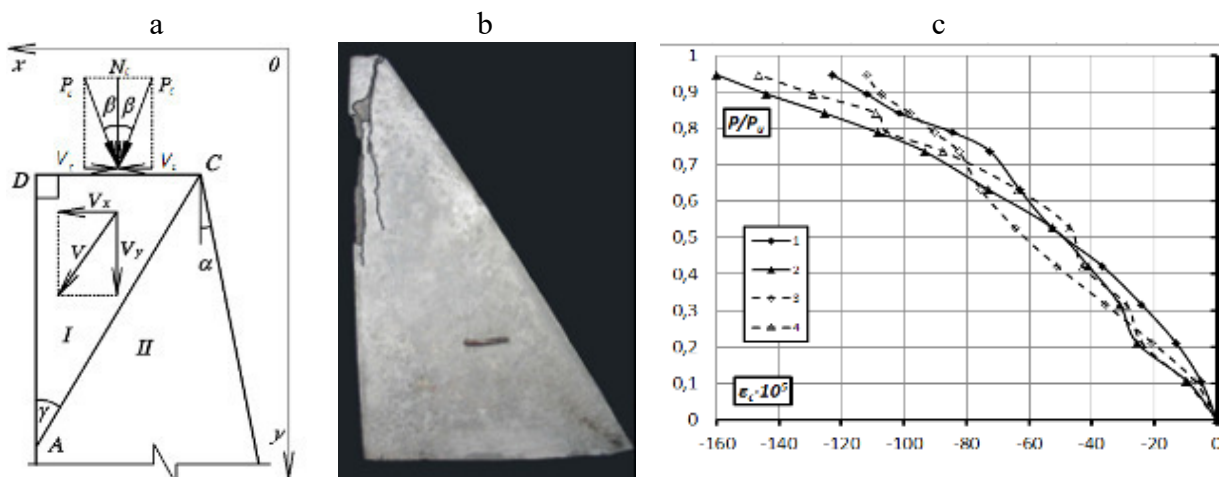

Figure 1 – Placing scheme of tensoresisterson truncated concrete wedges

There were two forms of wedge failure. The first one characterized by the failure area that crossed the top of obtuse angle and facet of the right angle (fig. 2, b). While applying force V_c to the right angle with increasing load angle β wedge strength is decreasing, and it is increasing with force V_c from the right angle.



Given: $h_c=DC$, b_w , α , β , f_{cd} , f_{ctd}

Figure 2 – Kinematically possible scheme (a), the failure character (b) and diagram « $\epsilon_c - P/P_u$ » for wedges that collapsed according to the first case (W1-30-0)

Formula for the ultimate load determination of such wedges is used:

$$P_c = m \left[2B \sqrt{(k - \text{tg}\gamma)^2 + 0,25(\text{ktg}\gamma + 1)^2} - (k - \text{tg}\gamma) \right] \times \frac{h_w b_w}{\text{tg}\gamma \cos \beta (1 \pm k_0 k)}, \quad (1)$$

$$\begin{aligned} \text{where } m &= f_{cd} - f_{ctd}, & B &= \sqrt{(1 + \chi / (1 - \chi)^2) / 3}, \\ \chi &= f_{ctd} / f_{cd}, & k_0 &= V_c / N_c, \\ P_c &= N_c / \cos \beta; \end{aligned}$$

unknown parameters are P_c , $k = V_x / V_y$ and the angle γ (fig. 2, a).

The shear plane crossed the top of right angle and the facet of obtuse angle when the second failure form occurred (fig. 3, b). The failure mode corresponded to the accepted kinematical scheme (fig. 3, a).

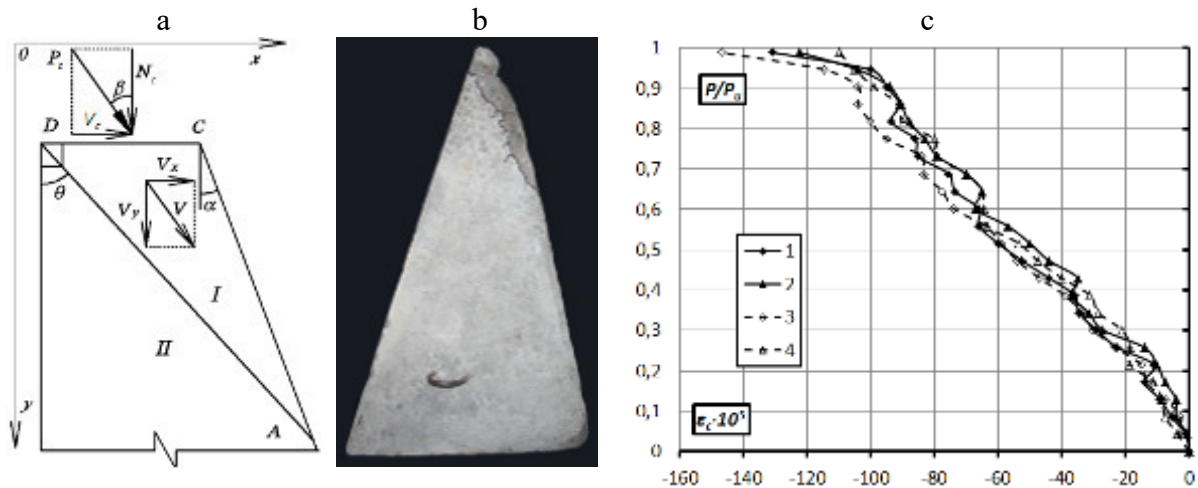

Given: $h_c, b_w, \alpha, \beta, f_{cd}, f_{ctd}$

Figure 3 – Kinematically possible scheme (a), the failure character (b) and diagram « $\epsilon_c - P/P_u$ » for wedges that collapsed according to the second case (W1-30-20)

In this case the strength has being proposed to evaluate as:

$$P_c = m \left[2B \sqrt{(k - \operatorname{tg} \theta)^2 + 0,25(k \operatorname{tg} \theta + 1)^2} - (k - \operatorname{tg} \theta) \right] \times \frac{h_w b_w}{\cos \beta (\operatorname{tg} \theta - \operatorname{tg} \alpha) (1 + k_0 k)}, \quad (2)$$

here unknown variables are P_c , $k = V_x/V_y$, angle θ (fig. 3, a).

Despite the seemingly brittle failure character of wedges the substantial compression deformations were fixed on the failure plane. They are close to ϵ_{cu} values on the diagrams of concrete mechanical state. Diagrams « $\epsilon_c - P/P_u$ » became warped that testified about the local plasticity zones existence (fig. 2, c and 3, c).

Gvozdev specimens (4 twins) were made of the same batch with wedges.

The specimens failure took place by the surface that crossed the shear plane and was almost congruent with it (fig. 4, b). The strain gages (fig. 4, c) indicated the presence of compressed and tensile sections of failure surface: in the middle part of design section tension was fixed, whereas compression has been found near inlet corners.

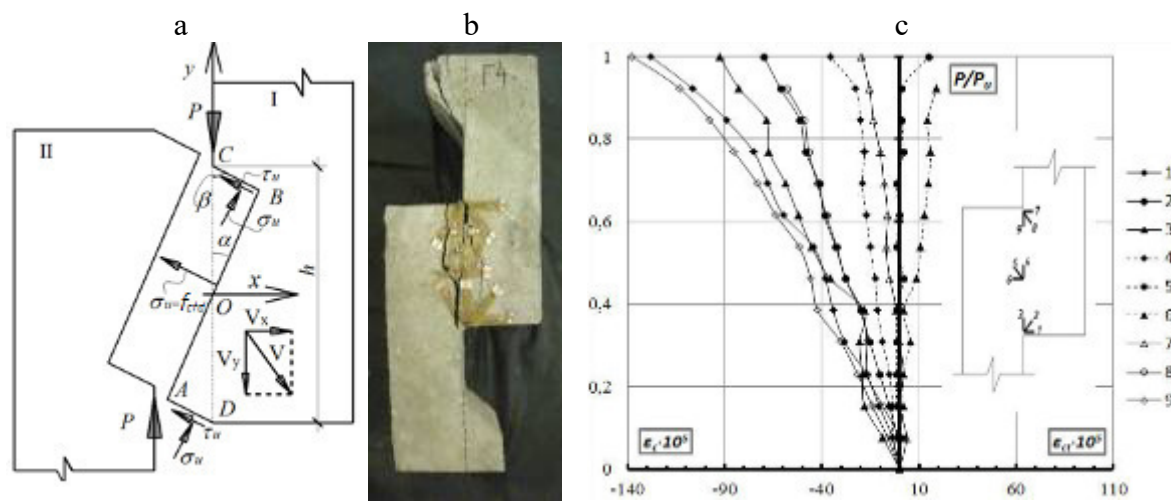

Given: h, b, f_{cd}, f_{ctd}

Figure 4 – Kinematically possible scheme (a), the failure character (b) and the diagram of relative concrete deformations from the load level « $\epsilon_c - P/P_u$ » (c) for Gvozdev specimens

The Gvozdev specimens strength has been calculated as:

$$P = m \left[2B \sqrt{(k - tg\beta)^2 + 0,25(ktg\beta + 1)^2} - (k - tg\beta) \right] \times \frac{hbtg\alpha}{tg\beta + tg\alpha} + \frac{hbf_{cid}tg\beta(k + tg\alpha)}{tg\beta + tg\alpha}, \quad (3)$$

where unknown variables are P , $k = V_x / V_y$ and angles α and β (fig. 4, a).

The limitation $\Sigma X=0$ was used by the task solution.

Crucial keys had the thickness $b_k = 150$ mm and height $h_k = 200$ mm with correlation of their dimensions $l_k/h_k = 0,25$ that provided non-shear failure with maximum strength provision. Bar reinforcement of reinforced concrete keys has been selected so that two bars located in the middle height of key corresponded to the four bars located in the upper and lower parts of the key (for two twin specimens). One sample was concrete.

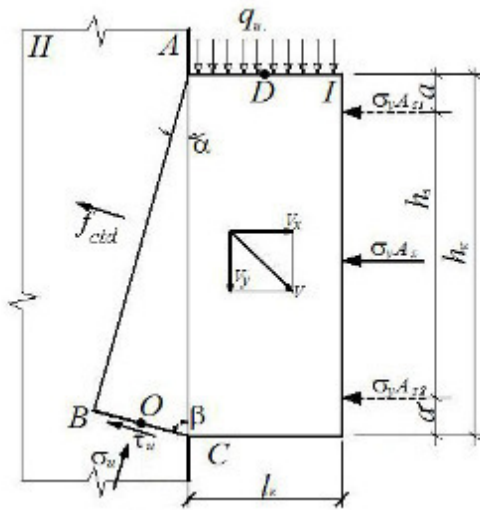

Given:

$h_k, b_k, l_k, A_s, \sigma_y, f_{cd}, f_{cid}$

Find q_u

Figure 5 – Kinematically possible scheme of reinforced concrete keys failure

For making the specimens the concrete of higher strength was used with cement M700 mark addition [18].

The failure character of keys principally didn't differ with different reinforcement distribution by the section height (fig. 6, a, c). Spacing the reinforcement in two levels led to the increasing of concrete compression deformations up to 50% (fig. 6, b, d). Besides the reinforcement of the upper level begins to work earlier comparing to its central placing. In the reinforcement of the lower level the dowel effect has being observed [19]. The keys strength with dual reinforcement is up to 10% bigger comparing with single.

The ultimate load of keys has being proposed to calculate by the formula that answered to the design scheme on the fig. 5:

$$q_u = (m \left[2B \sqrt{(k - tg\beta)^2 + 0,25(ktg\beta + 1)^2} - (k - tg\beta) \right] \times \frac{tg\alpha}{tg\alpha + tg\beta} + f_{cid}(k + tg\alpha) \times \frac{tg\beta}{tg\alpha + tg\beta} + \frac{\sigma_y(A_{s1} + A_{s2})k}{b_k h_k}) \frac{1}{\gamma}, \quad (4)$$

where $\gamma = \frac{l_k}{h_k}$, and the unknown parameters are q_u , $k = V_x / V_y$, angles α , β . Calculating

of q_u is made within the realization of limitations: $\Sigma M_B = 0$, $\Sigma M_O = 0$, $\Sigma M_D = 0$.

In the case of one-level reinforcement placing the space of reinforcement in formula (4) equals $A_s = A_{s1} + A_{s2}$.

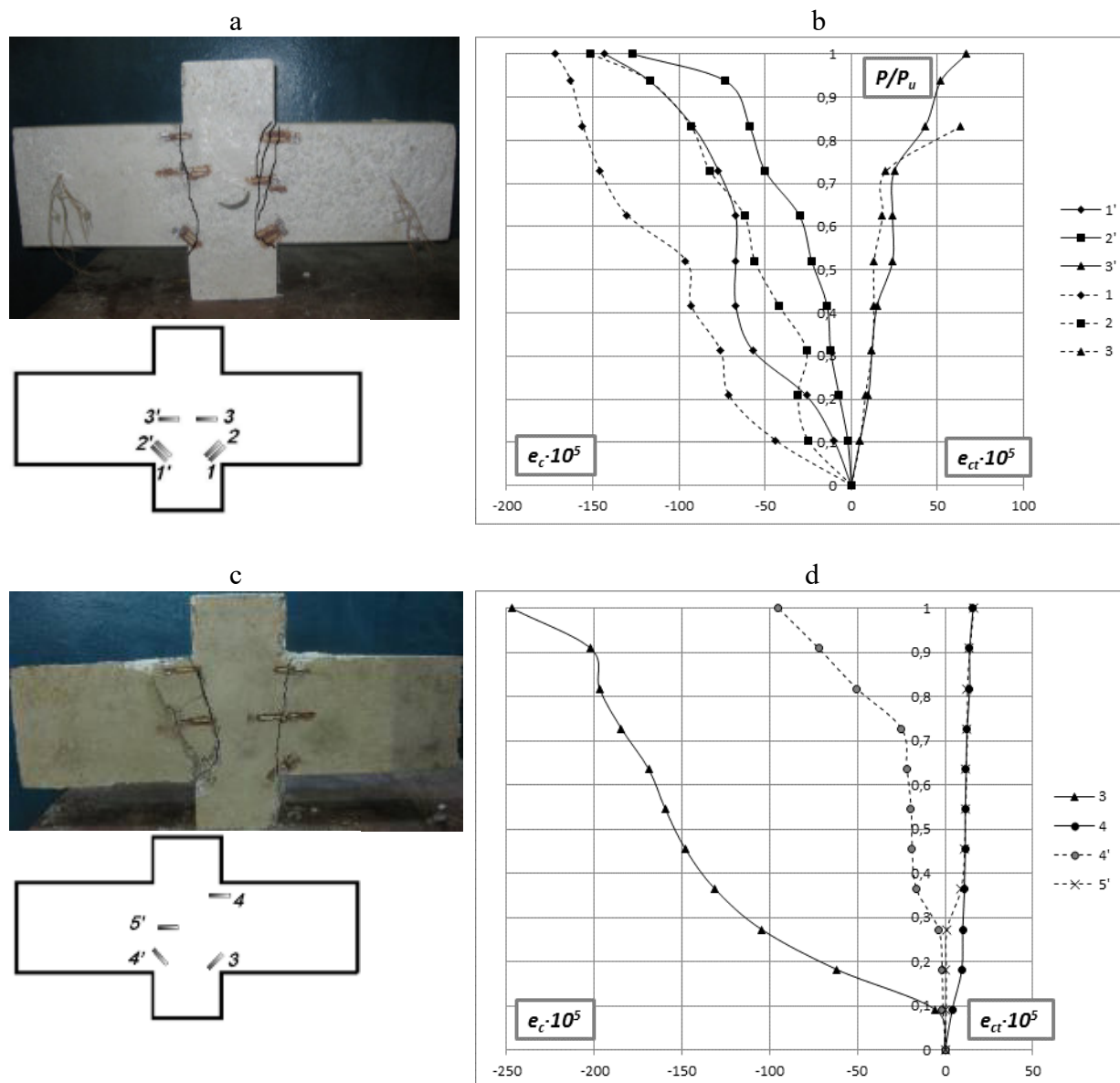

Figure 6 – The failure character (a) and diagram « $\varepsilon_c (\varepsilon_{ct}) - P/P_u$ » (b) for reinforced concrete keys with one-level and two-level (c, d) plating of reinforcement

The ultimate loads of all elements were calculated with the help of variation method of concrete plasticity theory. The method is based on the model of rigid-plastic solid and solution in dissoluble functions of velocities. The main point of the method consists of composition of kinematic scheme of failure (fig. 2, a, fig. 3, a, fig4, a, fig. 5). In terms of the scheme the method function is written. It is positive and on its real stress-strain state reaches its minimum that equals zero. From this condition we have the function for the ultimate load determination (1) – (4).

For each of the shear cases as the failure forms the mean arithmetic relation of theoretical $f_{sh}^{calc} = q_u l_k / h_k$ to experimental f_{sh}^{test} strength $\bar{X} = f_{sh}^{calc} / f_{sh}^{test}$, square mean deviation σ_{n-1} and factor of a variation v specified relation were determined. The general factors are $\bar{X} = 0,958$, $\sigma_{n-1} = 0,051$, $v = 5,3\%$. For better visualization the theoretical and experimental results comparison is represented in fig. 7.

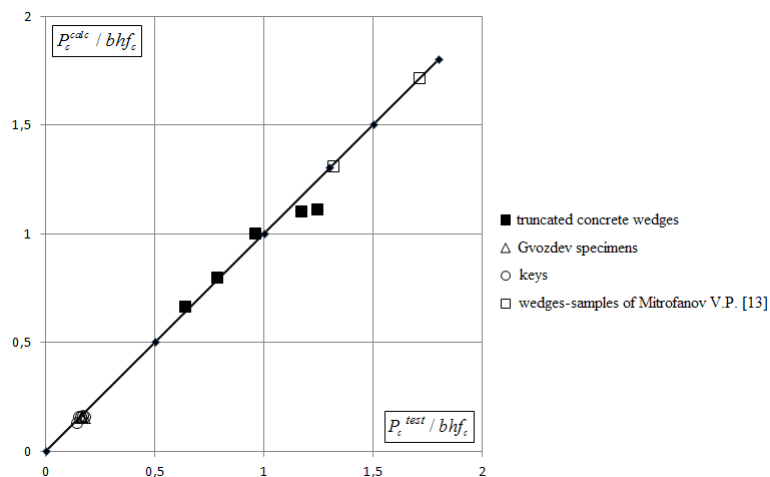

Figure 7 – Comparison of theoretical and experimental strength of specimens

Besides of mentioned above elements the beams investigation was conducted on the shear force in cross section. The first series consisted of 9 samples where concrete of three different classes was used. Concrete placing took place in a climate of «Poltavtransbud» plant within the metal formwork using concrete mixer of constrained action and shaker table for concrete mix packing. The second series consisted of two specimens where concrete of two different types was used: with adding of polypropylene fiber and without it. The aim of this testing series was the verification of possibility of reinforced concrete structures making with higher strength concrete in laboratory conditions.

Testing samples presented the beams of rectangular cross section with the dimensions $b \times h = 120 \times 180$ mm, and length 1500 mm. The first series were reinforced by space frames with longitudinal bars $4\text{Ø}16$ A400C, transverse bars $2\text{Ø}6$ A240C with 200 mm interval. As the assembling reinforcement bars were $2\text{Ø}6$ A240, joint bars were $\text{Ø}6$ A240C. In the beams of second series bars were $2\text{Ø}20$ A400C as the longitudinal reinforcement (fig. 8).

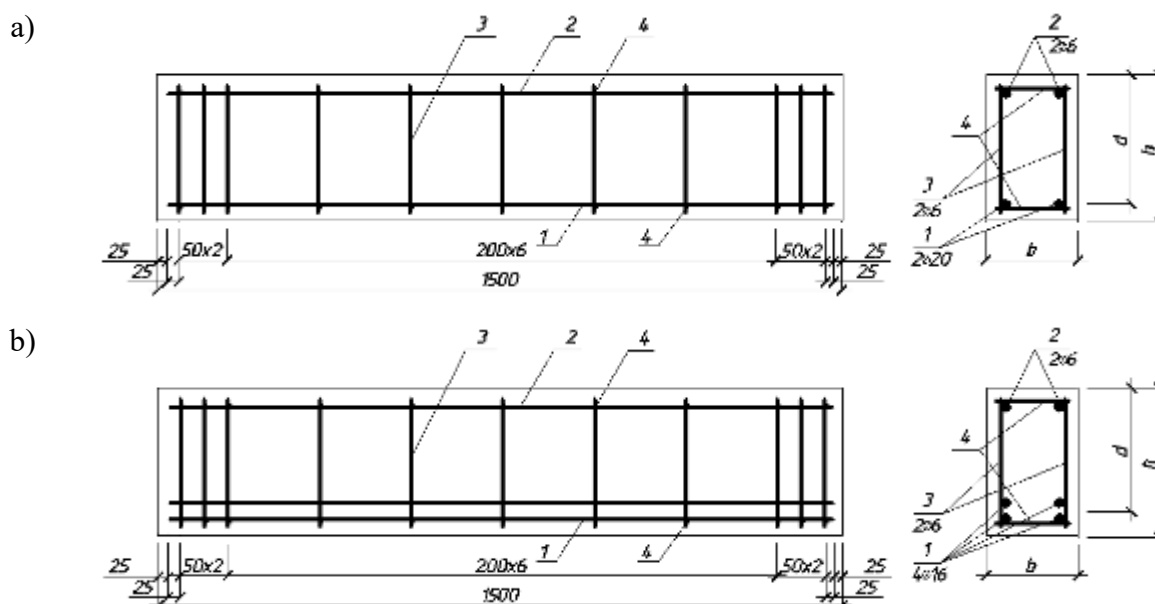

Figure 8 – Geometrical dimensions and reinforcement of beams:

a – first series; б – second series;

1 – longitudinal main reinforcement; 2 – handling reinforcement;

3 – transverse reinforcement; 4 – binding bars

Investigation of testing samples took place in laboratory setup of reinforced concrete and masonry structures and strength of materials chair according to the scheme of «pure bending», the relative span was $a/d= 2,3$ (fig. 9).



Figure 9 – Investigation of beam 1B – FC – 1 on flexure

In all beams by the load level of $V/V_u \approx 0,4$ normal cracks appeared first in the middle third of span. During next load stages their opening width increased, inclined cracks appeared (by $V/V_u \approx 0,55$). Beams failure took place by means of shear of compressed zone above dangerous oblique crack (fig.10). Displacement of certain blocks along the failure plane took place that is being realized only in the presence of non-elastic deformations on it. By holding on the last load level or load decreasing (over-bound state) failure accompanied with concrete breaking and essential bending of longitudinal reinforcement in the place of inclined crack crossing. It confirmed the presence of dowel effect. Ultimate beams deflections were 10 – 13 mm on the average.

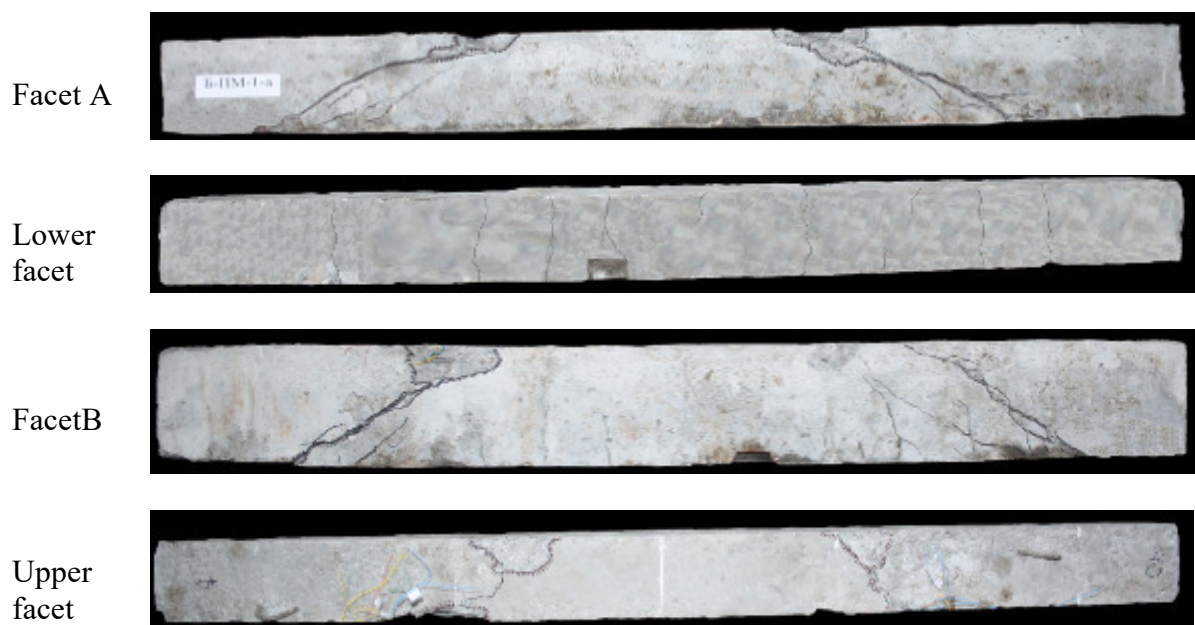

Figure 10 – Failure character of testing beam B-HS-1-a

Theoretical strength of beams was calculated according to the SNiP [20] and DBN [21], results of theoretical and experimental strength comparison are represented in the fig. 11.

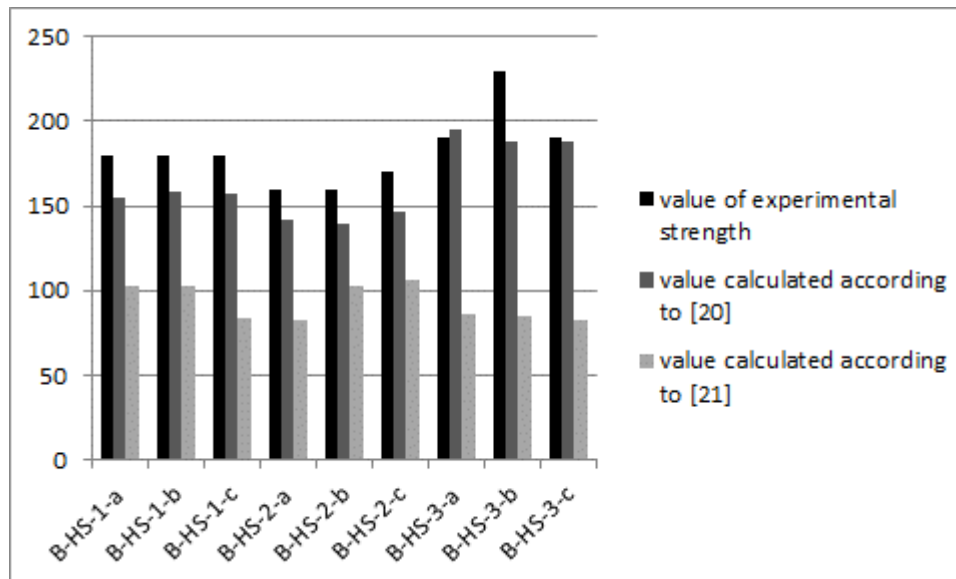

Figure 11 – Comparison of theoretical and experimental strength of beams

Conclusions. Experiments confirmed theoretical kinematical schemes of failure and presence of local plasticity zones regardless of brittle failure character of higher strength concrete elements. Comparing design of theoretical strength calculated with variation method of plasticity theory with experimental strength showed their sufficient proximity. Failure character of testing beams principally didn't differ from failure of bending elements by sloping section of medium strength concrete. Standard design method of beams strength by cross sections showed essential deviation with results of experimental investigation. So, it needs further improvement.

References

1. Берг О. Я. Высокопрочный бетон / О. Я. Берг, Е. Н. Щербаков, Г. Н. Писанко. – М. : Стройиздат, 1971. – 208 с.
2. Десов А. Е. Об эффективности применения высокопрочных и быстротвердеющих бетонов / А. Е. Десов, В. М. Москвин // Бетон и железобетон. – 1966. – №7. – С. 8 – 12.
3. Исследования бетонов на высокопрочных цементах / В. И. Сытник, С. В. Глазкова, П. И. Белик, Г. С. Язова // Высокопрочные бетоны. Сб. науч. тр. – К. : Будівельник, 1967. – С. 23 – 26.
4. Батраков В. Г. Модифицированные бетоны / В. Г. Батраков — М. : Стройиздат, 1998. — 768 с.
5. Каприелов С. С. Общие закономерности формирования структуры цементного камня и бетона с добавкой ультрадисперсных материалов / С. С. Каприелов // Бетон и железобетон. – 1995. – №6. – С. 16 – 20.
6. Корсун А. В. Напружено – деформований стан стиснутих залізобетонних елементів з високоміцних модифікованих бетонів, в тому числі в умовах нагрівання до +200°C: автореф...дис. канд. наук: 05.23.01 / А. В. Корсун. – Макеевка, 2007. – 21 с.
7. Mphonde A. G. Shear tests of high- and low-strength concrete beams without stirrups / A. G. Mphonde, G. C. Frantz // ACI Journal. – 1984. – Vol. 81. – P. 350 – 357.
<https://www.concrete.org/publications/internationalconcreteabstractsportal/m/details/id/10690>
8. Ahmad S. H. Shear capacity of reinforced high-strength concrete beams / S. H. Ahmad, A. R. Khaloo, A. Poveda // ACI Journal. – 1986. – Vol. 83, № 2. – P. 297 – 305.
<https://www.concrete.org/publications/internationalconcreteabstractsportal/m/details/id/10433>
9. Nilson A. H. High strength concrete: an Overview of Cornell Research // Proc. Symp. On Utilization of high strength concrete (June 1987). – Stavanger, Norway, 1987. – P. 85 – 118.

10. Elzanaty A. H. *Shear capacity of reinforced concrete beams using high-strength concrete* / A. H. Elzanaty, A. H. Nilson, F. O. Slate // *ACI Journal*. – 1986. – Vol. 83 – P. 290 – 296.
<https://www.concrete.org>
11. Kaufman M. K. *Structural behavior of high strength concrete prestressed I-beams* / M. K. Kaufman, J. A. Ramirez // *Final Report*. – Purdue Univ., Lafayette.
<http://docs.lib.purdue.edu/cgi/viewcontent.cgi?article=2493&context=jtrp>
12. Лазарева О. М. Міцність нерозрізних балок із високоміцних бетонів: автореф. дис. на здобуття наук. ступеня канд. техн. наук: спец. 05.23.01 – будівельні конструкції, будівлі та споруди / О. М. Лазарева. – Полтава: ПолтНТУ, 2014. – 21 с.
13. Митрофанов П. Б. Розрахунок міцності стиснутих залізобетонних елементів із високоміцних бетонів на основі деформаційної моделі з екстремальним критерієм: автореф. дис. на здобуття наук. ступеня канд. техн. наук: спец. 05.23.01 – будівельні конструкції, будівлі та споруди / П. Б. Митрофанов. – Полтава: ПолтНТУ, 2013. – 24 с.
14. Демченко О. В. Напружено-деформований стан центрально стиснутих трубобетонних елементів із ядрами з високоміцних бетонів: автореф. дис. на здобуття наук. ступеня канд. техн. наук: спец. 05.23.01 – будівельні конструкції, будівлі та споруди / О. В. Демченко. – Полтава: ПолтНТУ, 2015. – 20 с.
15. Митрофанов В. П. Вариационный метод в теории идеальной пластичности бетона / В. П. Митрофанов // *Строительная механика и расчет сооружений*. – 1990. – №6. – С. 23 – 28.
16. Качан Т. Ю. Розрахунок міцності суцільних та склеєних залізобетонних (бетонних) елементів на зріз варіаційним методом: автореф. дис. на здобуття наук. ступеня канд. техн. наук: спец. 05.23.01 – будівельні конструкції, будівлі та споруди / Т. Ю. Качан. – Полтава: ПолтНТУ, 2012. – 23 с.
17. Результати експериментальних досліджень міцності балок із бетону підвищеної міцності за похилими перерізами / О. О. Довженко, Т. Ю. Качан, О. О. Мальована, В. Ю. Борбич // *Будівельні конструкції. Науково-технічні проблеми сучасного залізобетону: Міжвідомчий науково-технічний збірник наукових праць (будівництво)*. – Вип. 78, Кн. 1. – К: НДІБК, 2013. – с. 565 – 571.
www.irbis-nbuv.gov.ua/.../cgiirbis_64.exe?...
18. Довженко О. О. Про можливість застосування теорії пластичності до розрахунку міцності елементів із високоміцного бетону / О. О. Довженко, В. В. Погрібний, О. О. Куриленко // *Комунальне господарство міст: наук.-техн. збірник – Харків, 2012 – Вип. 105. – С. 74 – 82.*
<http://khg.kname.edu.ua/index.php/khg/article/view/813/807>
19. Застосування високоміцних бетонів у стикових з'єднаннях / О. О. Довженко, В. В. Погрібний, Л. В. Карабаш, О. О. Куриленко // *Бетон и железобетон в Украине*. – 2011. – №1. – С. 2 – 4.
20. СНиП 2.03.01-84*. *Бетонные и железобетонные конструкции [Введены с 1986-01-01]*. – М. : ЦИТП Госстроя СССР, 1989. – 88 с. – (Скасовані 2011-07-01).
21. ДБН В.2.6-98:2009. *Бетонні та залізобетонні конструкції. Основні положення [Чинні від 2011-07-01]*. – К. : Мінрегіонбуд України, ДП «Укрархбудінформ», 2011. – 71 с. – (Державні будівельні норми).

© Maliovana O.O.