

O. MARTYNENKO, YU. HUSIEVA, I. CHUMACHENKO

## THE METHOD OF EARNED REQUIREMENTS FOR PROJECT MONITORING

The requirements management processes largely determine the success of a project and should ensure its adaptability to changes in the requirements of stakeholders. Today, these processes are not sufficiently formalized, in particular, for traditional project management. Consequently, management and control requirements should be developed and formalized. The **subject matter** of this study is methods that manage the requirements of stakeholders in projects. The **aim** of the article is to increase the effectiveness of monitoring the requirements of the project stakeholders by developing the method of earned requirements and the model that formalizes this method. To achieve the **goal**, the following tasks are completed: integration of the hierarchical structure of requirements and the classical hierarchical structure of the project activities for obtaining the matrix of control points to meet the requirements of stakeholders linking a certain requirement to the activities that should be carried out to execute the project; development of the method of monitoring requirements; development of a functional model of the suggested method. The **methods** used are: the methods of decomposition, functional modeling and the modified method of earned volume. The following **results** were obtained: the method of requirement monitoring was developed; this method enables monitoring carrying out the requirements of project stakeholders in time according to the volume of actually used resources by analogy with the method of earned volume. The approach based on the integration of the hierarchical structure of requirements and the hierarchical structure of the project activities enables supplementing the existing methods of classification of project stakeholders by the indicator of resource requirements. **Conclusions.** The suggested method formalizes the requirements management processes in the project, enables determining the resource load of requirements, adds this factor to the existing model of requirements. This method is practically supported by the functional model in the IDEF0 notation. The areas of project management (according to the PMBOK standard) where the use of the suggested approach is the most effective are identified. In the process of generating output data for this method use, certain constraints should be considered; these constraints are determined by different types of project stakeholders' requirements and the dimension of the sets of "requirements" and "activities".

**Keywords:** project stakeholders, management processes, functional modelling, PMBOK 5.

### Introduction

All projects face changes that are the results of changes in the requirements of key stakeholders of a project. The project adaptability to changes is ensured by various tools in traditional and "flexible" project management. Traditional project management [1] considers the change management through the process of the integrated change control – the process that continues throughout the whole project and lies in rejecting or approving change requests that are typically generated as monitoring and control outputs. In fact, documenting and controlling changes but not their justification and management are mentioned. Changes complexity and cost in the traditional approach are growing dramatically when the project starts. Agile-methodologies of project management have a greater degree of adaptability due to its iteration, but it is mainly used in IT-projects [2–4]. In turn, Requirements Engineering describes the process of identifying, documenting and fulfilling requirements and is a part of system and computer engineering [5–7]. A characteristic feature of agile methodologies is recording project resources, that is project adaptability to changes is ensured by the changes of the project content (in traditional methodologies the content is fixed).

So there is a motivation to develop more effective methods of managing stakeholder requirements for projects that are executed according to the principles of traditional project management when changes in the project content are undesirable.

The **aim** of this paper is to improve the monitoring requirements of the project stakeholders by means of the development of appropriate methods and models.

### Presenting main material

The execution of any project is accompanied by fulfilling the requirements of its stakeholders. A certain requirement of project stakeholders can be put into correspondence with project activities that ensure carrying out this requirement.

This can put a request in accordance with the project stakeholders and to ensure compliance with this requirement. The work [8] deals with the results of the integration of the hierarchical structure requirements (Requirement Breakdown Structure, RBS) and classical hierarchical structure of the project (Work Breakdown Structure, WBS). The matrix of stakeholders controlled points obtained by their intersection connects a certain requirement with the activities that should be performed to fulfill the requirement. This approach enables monitoring carrying out the stakeholders' requirements with the set level of detalization, which, in turn, is determined by the level of detalization of WBS and RBS.

Certain resources are used while project planning. So, using the matrix of control points for fulfilling stakeholders' requirements all activities can be grouped according to the matrix of control points or according to individual stakeholders defining their resource intensiveness. This is the procedure of WBS development according to proper principles.

Allocating certain requirements to certain project stakeholders enables monitoring their fulfillment over time according to the actual amount of used resources by analogy with the method of earned value [1, 9].

Earned Value Management (EVM) is the methodology that combines the assessment of the content, schedule and resources to measure the project progress and achievement of its efficiency. Three key factors for each work package are monitored with the help of EVM:

- planned volume (PV) that is the authorized budget allocated to the planned activities;
- earned value (EV) that is the amount of work expressed in terms of the authorized budget;
- actual cost (AC) that is the actual costs spent during a certain period of time.

Let's define key factors for analyzing the earned value requirements of the project stakeholders – the factors of the method of monitoring requirements earned requirements method (ERM).

PR is planned volume of requirements that must be fulfilled for a specified time (estimated figure);

ER is the actual volume of requirements which was performed for a certain period of time (determined by the results of monitoring);

AC is the actual volume of resources in terms of money spent on the project for a certain period of time (determined by the results of monitoring);

SR is the scheduled deviation in terms of the requirements of the project stakeholders ( $SR = ER - PR$ ). Positive values are favorable, negative ones are poor. Zero value indicates the performance of targets;

CR is the value deviation in terms of the requirements of the project stakeholders ( $CR = ER - AC$ ). Positive values are favorable, negative ones are poor. Zero value indicates the performance of targets;

SPIR is the scheduled index in terms of the requirements of the project stakeholders ( $SPIR = ER / PR$ ). The value of the factor greater than 1 is favorable, less than 1 is poor. The indicator of value which is equal to one indicates the performance of targets;

CPIR is the value deviation in terms of the requirements of the project stakeholders ( $CPIR = ER / AC$ ). The value of the indicator greater than 1 is favorable, less than 1 is unfavorable. The indicator of value which is equal to one indicates the performance of targets.

Graphical interpretation of the suggested method is shown in Fig. 1: three curves PR, ER and AC are constructed for a conventional design; the schedule deviation (SR) and value deviation (CR) in terms of the requirements of stakeholders are shown. Outstripping the requirements and saving of the planned volume of the project budget occur while performing the project at the moment of time  $T$ .

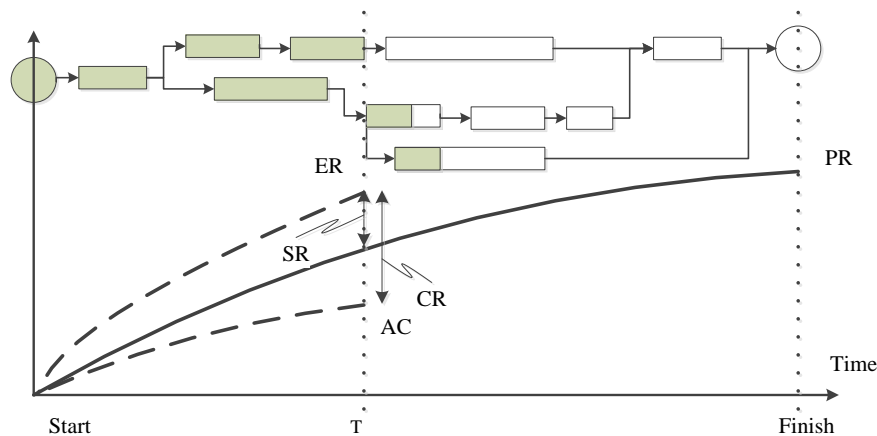

Fig. 1. The analysis of the earned value requirements of project stakeholders

The interpretation of the key indicators of ERM method is shown in Table. 1. It can be noted that the data



shown is the basis not only for monitoring but for the forecast of the project.

Table 1. The interpretation of key factors

The factors of project fulfillment		Requirements		
		SR>0; SPIR>1	SR=0; SPIR=1	SR<0; SPIR<1
Cost	CR>0; CPIR>1	plan outstripping, budget savings	fulfilling the planned requirements, budget savings	lag in fulfilling the requirements, budget savings
	CR=0; CPIR=1	plan outstripping, budgetary compliance	fulfilling the planned requirements, budgetary compliance	lag in fulfilling the requirements, budgetary compliance
	CR<0; CPIR<1	plan outstripping, budget deficit	fulfilling the planned requirements, budget deficit	lag in fulfilling the requirements, budget deficit

Effective implementation of the method of requirements monitoring involves the use of A Guide to the Project Management Body of Knowledge (PMBOK) [1]. To determine the role of the suggested method for effective project management the relationships between requirements and methods of monitoring processes and PMBOK 5 knowledge areas was analyzed. The results of the analysis are given

in fig. 2 which shows the spheres of project management, where this method is the most applicable.

The following designations are used:  is one or more processes where this method can be conceptually used;  is one or more processes for which this method is less important.

Knowledge areas	Project management process groups				
	Initiating Process Group	Planning Process Group	Executing Process Group	Monitoring & Controlling Process Group	Closing Process Group
4. Project Integration Management	4.1 Develop Project Charter ↑	4.2 Develop Project Management Plan ↑↑	4.3 Direct and Manage Project Work ↑↑	4.4 Monitor and Control Project Work 4.5 Perform Integrated Change Control ↑↑	4.6 Close Project or Phase ↑
5. Project Scope Management		5.1 Plan Scope Management 5.2 Collect Requirements 5.3 Define Scope 5.4 Create WBS ↑↑		5.5 Validate Scope 5.6 Control Scope ↑↑	
6. Project Time Management		6.1 Plan Schedule Management 6.2 Define Activities 6.3 Sequence Activities 6.4 Estimate Activity Resources 6.5 Estimate Activity Durations 6.6 Develop Schedule ↑↑		6.7 Control Schedule ↑↑	
7. Project Cost Management		7.1 Plan Cost Management 7.2 Estimate Costs 7.3 Determine Budget ↑↑		7.4 Control Costs ↑↑	
8. Project Quality Management		8.1 Plan Quality Management ↑	8.2 Perform Quality Assurance ↑	8.3 Control Quality ↑	
9. Project Human Resource Management		9.1 Plan Human Resource Management ↑	9.2 Acquire Project Team 9.3 Develop Project Team 9.4 Manage Project Team ↑		
10. Project Communications Management		10.1 Plan Communications Management ↑↑	10.2 Manage Communications ↑↑	10.3 Control Communications ↑↑	
11. Project Risk Management		11.1 Plan Risk Management 11.2 Identify Risks 11.3 Perform Qualitative Risk Analysis 11.4 Perform Quantitative Risk Analysis 11.5 Plan Risk Responses ↑↑		11.6 Control Risks ↑↑	
12. Project Procurement Management		12.1 Plan Procurement Management ↑	12.2 Conduct Procurements ↑	12.3 Control Procurements ↑↑	12.4 Close Procurements ↑
13. Project Stakeholder Management	13.1 Identify Stakeholders ↑↑	13.2 Plan Stakeholder Management ↑↑	13.3 Manage Stakeholder Engagement ↑↑	13.3 Control Stakeholder Engagement ↑↑	

Fig. 2. The method of monitoring requirements and PMBOK 5

For practical use of the suggested method the process of its implementation should be described. Within this work it is done using the methodology of functional design and graphic description of IDEF0

processes, which is designed to formalize and describe business processes.

Fig. 3 shows the contextual level of the suggested model.

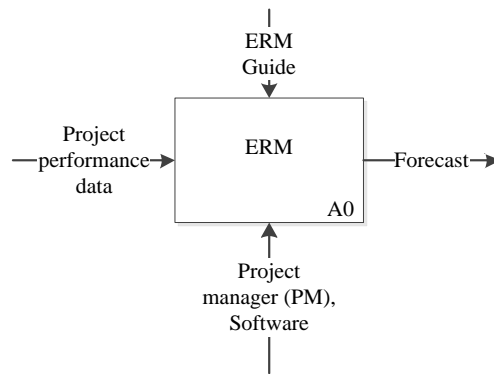

Fig. 3. The contextual model of the suggested method

Fig. 4 shows the decomposition of the process of using the method of monitoring project requirements. The arrows on the model presents inputs, outputs, mechanisms and control for the corresponding process.

Works [10–12] deal with the general approach to such modelling. The process approach to the decomposition of project stakeholders' requirements is also suggested.

The authors compared the hierarchical structure requirements (Requirement Breakdown Structure, RBS) and hierarchical processes (Process Breakdown Structure, PBS). The matrix of control points of fulfilling stakeholders' requirements obtained by their intersection connects a certain requirement with the processes that should be completed for its implementation. This approach enables monitoring the fulfillment the stakeholders' requirements.

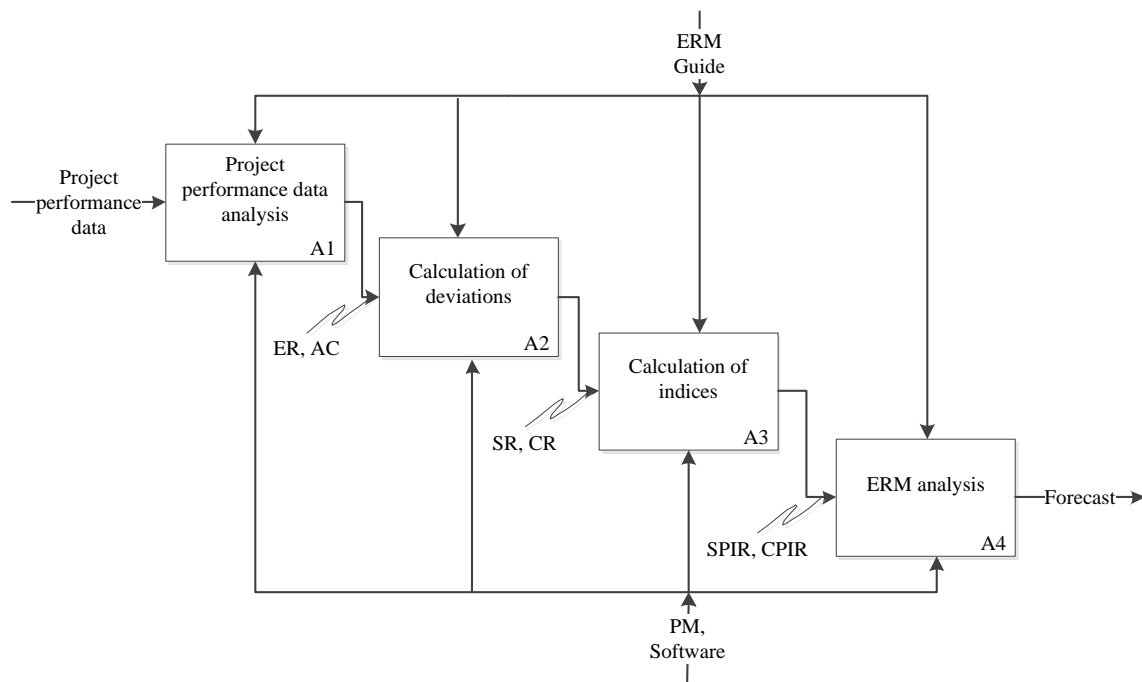

Fig. 4. Decomposition of ERM pattern use

### Conclusions and recommendations for further research

The authors suggested the approach which is based on the integration of the hierarchical structure of requirements and the hierarchical structure of the project and enables adding the factor of resource requirements which can be defined in monetary terms to the existing methods of classifying project stakeholders.

Further, it is necessary to create mechanisms of output data development to use this approach for considering available different types of stakeholder requirements which can be mutually exclusive (two or

more requirements cannot be simultaneously fulfilled within the project); supporting (the fulfillment of one requirement can help through the other one); independent (the fulfillment of a requirement does not affect the fulfillment of the other one); mandatory (requirements that must be met, for example, in accordance with the current legislation) as well as the fact that the ratio of "requirements-activities" looks like  $m \times n$ .

The method of monitoring requirements that enables monitoring the fulfillment of project stakeholders' requirements during proper time according to the actual amount of resources spent by analogy with the method of earned value.

## References

1. *A Guide to the Project Management Body of Knowledge (PMBOK® Guide). Fifth Edition.* (2013), Newtown Square, Pa.: Project Management Institute, Inc., 614 p.
2. Highsmith, J. (2013), *Adaptive software development: a collaborative approach to managing complex systems*, Addison-Wesley.
3. Horkoff, J., Yu, E. (2014), "Interactive goal model analysis for early requirements engineering", *Requirements Engineering*, No. 21(1), pp. 29-61. Doi: 10.1007/s00766-014-0209-8.
4. Darwish, N. R., Megahed, S. (2016), "Requirements Engineering in Scrum Framework". *Requirements Engineering*, Vol. 149, no. 8, pp. 24-29. Doi: 10.5120/ijca2016911530.
5. Kotonya, G, Sommerville, I. (1998), *Requirements Engineering: Processes and Techniques*, John Wiley & Sons, 294 p.
6. Chemuturi, M. (2013), *Requirements Engineering and Management for Software Development Projects*, 266 p. Doi: 10.1007/978-1-4614-5377-2.
7. Miranda, E. (2011), "Time boxing planning: Buffered Moscow Rules", *ACM SIGSOFT Software Engineering Notes*, No. 36(6), pp. 1-5. Doi: 0.1145/2047414.2047428.
8. Husyeva, Yu. Yu., Chumachenko, I. V., Sydorenko, M. V. (2016), "Managing stakeholder education projects", *Bulletin of the NTU "KhPI". Series: strategic management, portfolio, program and project management* ["Upravlinnya zatsikavlenymy storonamy osvitykh proektiv", Visnyk NTU "KhPI". Seriya: Stratehichne upravlinnya, upravlinnya portfelyamy, prohramamy ta proektamy], No 2(1174), pp. 8–12.
9. *Practice Standard for Earned Value Management* (2005), Newtown Square, Pa.: Project Management Institute, Inc., 56 p.
10. Husyeva, Yu. Yu., Martynenko, O. S., Chumachenko, I. V. (2016), "Process approach to modeling and monitoring requirements of stakeholders", *Information technology and innovation in economics, project and program management* ["Protsesny pidkhid do modelyuvannya i monitorynhu vymoh zatsikavlenykh storig", Informatsiyni tekhnolohiyi ta innovatsiyi v ekonomitsi, upravlinni proektamy ta prohramamy], pp. 289–296.
11. Husyeva, Yu. Yu., Martynenko, O. S., Chumachenko, I. V. (2016), "Decomposition and formalizing the requirements of stakeholders in the process model", *International scientific-practical conference "Mathematical modeling of processes in economics and project and program management"* ["Dekompozitsiia ta formalizatsiia vymoh cteikkholderiv u protsesnykh modeliakh", Mezhdunarodnaia nauchno-praktycheskaia konferentsiia "Matematycheskoe modelyrovanye protsessov v ekonomyke y upravlenyy proektamy y prohramamy (MMP-2016)"], pp. 43–44.
12. Kadykova, I. M., Larina, S. O. (2016), "The formalization of processes - the basis of the development of information technology and project management software", *Project Management: Innovation, Nonlinearity, Synergetics: Materials of the VII International Scientific and Practical Conference of Graduate Students, Graduates and Researchers* ["Formalizatsiia procesiv – osnova rozrobky informacijnoyi tekhnologij upravlinnya proektamy ta prohramamy" Upravlinnya proektamy: innovatsiyi, nelineijnist, synergetyka: Materialy VII Mizhnarodnoyi naukovy-praktychnoyi konferentsiyi magistrantiv, aspirantiv ta naukovciv], pp. 44–47.

Receive 14.06.2017

*Відомості про авторів / Сведения об авторах / About the Authors*

**Мартиненко Олександр Сергійович** – Харківський національний університет міського господарства імені О. М. Бекетова, аспірант кафедри управління проектами в міському господарстві і будівництві, м. Харків, Україна; e-mail: asmartynenko@gmail.com, ORCID: 0000-0002-2055-2617.

**Мартыненко Александр Сергеевич** – Харьковский национальный университет городского хозяйства имени А. Н. Бекетова, аспирант кафедры управления проектами в городском хозяйстве и строительстве, г. Харьков, Украина; e-mail: smartynenko@gmail.com, ORCID: 0000-0002-2055-2617.

**Martynenko Oleksandr** – O. M. Beketov National University of Urban Economy in Kharkiv, Postgraduate Student at the Department of Project Management in Urban Economy and Construction, Kharkiv, Ukraine; e-mail: smartynenko@gmail.com, ORCID: 0000-0002-2055-2617.

**Гусева Юлія Юрїївна** – кандидат технічних наук, доцент, Харківський національний університет міського господарства імені О. М. Бекетова, доцент кафедри управління проектами в міському господарстві і будівництві, м. Харків, Україна; e-mail: yulia.guseva@kname.edu.ua, ORCID: 0000-0001-6992-543X.

**Гусева Юлия Юрьевна** – кандидат технических наук, доцент, Харьковский национальный университет городского хозяйства имени А. Н. Бекетова, доцент кафедры управления проектами в городском хозяйстве и строительстве, г. Харьков, Украина; e-mail: yulia.guseva@kname.edu.ua, ORCID: 0000-0001-6992-543X.

**Husieva Yuliia** – PhD. (Engineering Sciences), Associate professor, O. M. Beketov National University of Urban Economy in Kharkiv, Associate Professor at the Department of Project Management in Urban Economy and Construction, Kharkiv, Ukraine; e-mail: yulia.guseva@kname.edu.ua, ORCID: 0000-0001-6992-543X.

**Чумаченко Ігор Володимирович** – доктор технічних наук, професор, Харківський національний університет міського господарства імені О. М. Бекетова, завідувач кафедри управління проектами в міському господарстві і будівництві, м. Харків, Україна; e-mail: ivchumachenko@gmail.com, ORCID: 0000-0003-2312-2011.

**Чумаченко Игорь Владимирович** – доктор технических наук, профессор, Харьковский национальный университет городского хозяйства имени А. Н. Бекетова, заведующий кафедрой управления проектами в городском хозяйстве и строительстве, г. Харьков, Украина; e-mail: ivchumachenko@gmail.com, ORCID: 0000-0003-2312-2011.

**Chumachenko Igor** – Doctor of Sciences (Engineering), Professor, O. M. Beketov National University of Urban Economy in Kharkiv, Head of the Department of Project Management in Urban Economy and Construction, Kharkiv, Ukraine; e-mail: ivchumachenko@gmail.com, ORCID: 0000-0003-2312-2011.

## МЕТОД ОСВОЄНИХ ВИМОГ ДЛЯ МОНІТОРИНГУ ВИКОНАННЯ ПРОЕКТУ

Процеси управління вимогами значною мірою визначають успішність проекту і повинні забезпечувати його адаптивність до змін у вимогах зацікавлених сторін. На сьогодні ці процеси є недостатньо формалізованими, зокрема, для традиційного проектного менеджменту. Отже, є необхідність розробки та формалізації методів управління і контролю вимог. **Предметом** даного дослідження є методи управління вимогами стейкхолдерів у проектах. **Мета** статті – підвищення ефективності моніторингу вимог зацікавлених сторін проекту за рахунок розробки методу освоєних вимог та моделі, що формалізує цей метод. Для досягнення мети реалізовано наступні **завдання**: інтеграція ієрархічної структури вимог і класичної ієрархічної структури робіт проекту з отриманням матриці контрольних точок виконання вимог стейкхолдерів, що пов'язує певну вимогу з роботами, які необхідно здійснити для її виконання; розробка методу моніторингу вимог; побудова функціональної моделі запропонованого методу. Використано **методи** декомпозиції, функціонального моделювання, модифікований метод освоєного обсягу. Отримано такі **результати**: розроблено метод моніторингу вимог, який дозволяє відстежувати виконання вимог зацікавлених сторін проекту у часі у відповідності до обсягу фактично витрачених ресурсів за аналогією з методом освоєного обсягу. Підхід, що засновано на інтеграції ієрархічної структури вимог та ієрархічної структури робіт проекту, дозволяє доповнити існуючі методи класифікації зацікавлених сторін проекту показником ресурсомісткості вимог. **Висновки.** Запропонований метод формалізує процеси управління вимогами у проекті, дозволяє визначати ресурсне навантаження вимог, що доповнює існуючі моделі класифікації вимог цим показником. Підтримкою практичної реалізації методу є розроблена функціональна модель у нотації IDEF0. Визначено галузі проектного менеджменту (за стандартом РМВОК), для яких використання запропонованого підходу буде найбільш ефективним. У процесі формування вихідних даних для використання методу слід враховувати існування певних обмежень, які визначаються існуванням різних типів вимог зацікавлених сторін проекту і розмірністю множин "вимоги" та "роботи".

**Ключові слова:** стейкхолдери проекту, процеси управління, функціональне моделювання, РМВОК 5.

## МЕТОД ОСВОЕННЫХ ТРЕБОВАНИЙ ДЛЯ МОНИТОРИНГА ВЫПОЛНЕНИЯ ПРОЕКТА

Процессы управления требованиями в значительной степени определяют успешность проекта и должны обеспечивать его адаптивность к изменениям требований заинтересованных сторон. На сегодня эти процессы недостаточно формализованы, в частности, для традиционного проектного менеджмента. Следовательно, есть необходимость разработки и формализации методов управления и контроля требований. **Предметом** данного исследования являются методы управления требованиями стейкхолдеров в проектах. **Цель** статьи – повышение эффективности мониторинга требований заинтересованных сторон проекта за счет разработки метода освоённых требований и модели, которая формализует этот метод. Для достижения цели реализованы следующие **задачи**: интеграция иерархической структуры требований и классической иерархической структуры работ проекта с получением матрицы контрольных точек требований стейкхолдеров, связывающей определенное требование с работами, которые необходимо осуществить для его выполнения; разработка метода мониторинга требований; построение функциональной модели предложенного метода. Используются **методы** декомпозиции, функционального моделирования, модифицированный метод освоённого объема. Получены следующие **результаты**: разработан метод мониторинга требований, который позволяет отслеживать выполнение требований заинтересованных сторон проекта во времени в соответствии с объемом фактически израсходованных ресурсов по аналогии с методом освоённого объема. Подход, основанный на интеграции иерархической структуры требований и иерархической структуры работ проекта, позволяет дополнить существующие методы классификации заинтересованных сторон проекта показателем ресурсоемкости требований. **Выводы.** Предложенный метод формализует процессы управления требованиями в проекте, позволяет определять ресурсную нагрузку требований, дополняет существующие модели классификации требований этим показателем. Поддержкой практической реализации метода является разработанная функциональная модель в нотации IDEF0. Определены области проектного менеджмента (по стандарту РМВОК), для которых использование предложенного подхода будет наиболее эффективным. В процессе формирования исходных данных для использования метода следует учитывать существование определенных ограничений, которые определяются существованием различных типов требований заинтересованных сторон проекта и размерностью множеств "требования" и "работы".

**Ключевые слова:** информационно-телекоммуникационная сеть, факторы, риски, последствия, причинно-следственная диаграмма, коэффициенты влияния.

*Бібліографічні описи / Библиографические описания / Bibliographic descriptions*

**Мартиненко О. С., Гусева Ю. Ю., Чумаченко І. В. Метод освоєних вимог для моніторингу виконання проекту.** *Сучасний стан наукових досліджень та технологій в промисловості.* Харків. 2017. № 1 (1). С. 58–63.

**Мартыненко А. С., Гусева Ю. Ю., Чумаченко И. В. Метод освоённых требований для мониторинга выполнения проекта.** *Сучасний стан наукових досліджень та технологій в промисловості.* Харків. 2017. № 1 (1). С. 58–63.

**Martynenko O., Husieva Y., Chumachenko I. The method of earned requirements for project monitoring.** *Innovative technologies and scientific solutions for industries.* Kharkiv. 2017. No. 1 (1). P. 58–63.