

VS

VS

Ovcharenko Ye.I. – Candidate of Economic Sciences, associate professor, doctoral student, Management and Economic Security Department, Volodymyr Dahl East Ukrainian National University, Luhansk, Ukraine. evgen_ov@rambler.ru

PURPOSEFULNESS vs EXPEDIENCY PRAGMATICS IN MANAGEMENT IN SYSTEM OF ECONOMIC SECURITY OF THE ENTERPRISE

Background: Allocation and the description of the procedural principles of management in such system has to become an important point of studying of properties of system of economic security of the enterprise. Right establishment and the description of such principles allows to carry out intrinsic transitions between different models of representation of system for fuller understanding of its essence. **Aims:** Definition of conceptual signs and the principles of management in system of economic security of the enterprise against change of an ideological basis of creation of this system from purposefulness to expediency of actions of elements. **Results:** Attraction of the theory of functional systems to a system-creation in the field of economic security of the enterprise is considered expedient. The theory of functional systems belongs to biological approach in a systematology which propagandizes teleonomy understanding of the aim, – the aim is defined by expediency of behavior – the person as part of society, most often as the aim understands conscious or subconscious aspiration to a solution, instead of result of the decision. The functional system is capable to change of the aim of functioning if the adaptive result is unsatisfactory. Thus this change can happen almost instantly and an infinite number of times. Therefore the aim in functional system is a dynamic element inclined to repeated changes. Round it, it is difficult to construct system. It is possible only in case of a certain stability of the aim. Steadier elements of system are others: functions which are defined not on the basis of purposefulness, and on the basis of expediency of functioning of system, and behavioral stereotypes of people which are a part of system. **Conclusion:** The purposeful system of economic security of the enterprise isn't able to cope with a stream of dangerous situations because of impossibility so quickly to change own target reference points. Much more productive in this sense is SESE functioning on the basis of expediency of actions, instead of purposefulness. Such SESE can be created on the basis of a behavioral stereotype as system-creation factor. Attraction of the theory of functional systems to a system-creation in the field of economic security of the enterprise gives the chance to define aspects of creation of SESE on the basis of a behavioral stereotype.

Keywords: economic security, enterprise, system, aim, management.

()

()

"1

2

?

3

1 "

2 "

3

, 1912.

Fragment of text containing various symbols and characters, including a closing parenthesis at the top left.

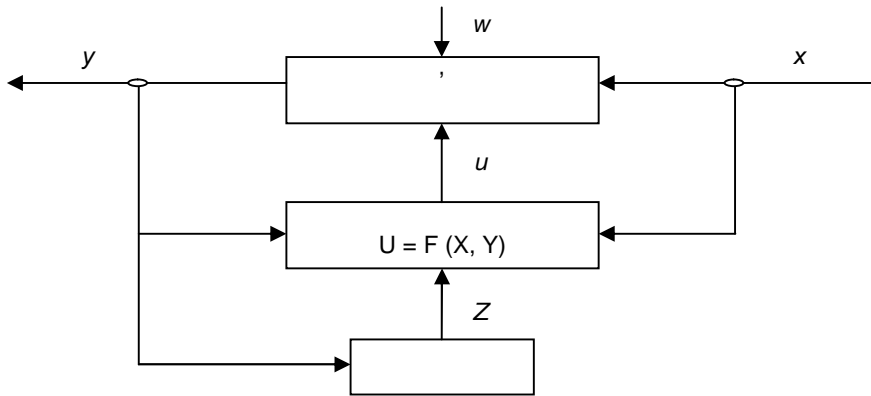

Fragment of text containing mathematical symbols and variables, including the function $U = F(X, Y)$ and the variable z .

⁴ [4, . 9-10].

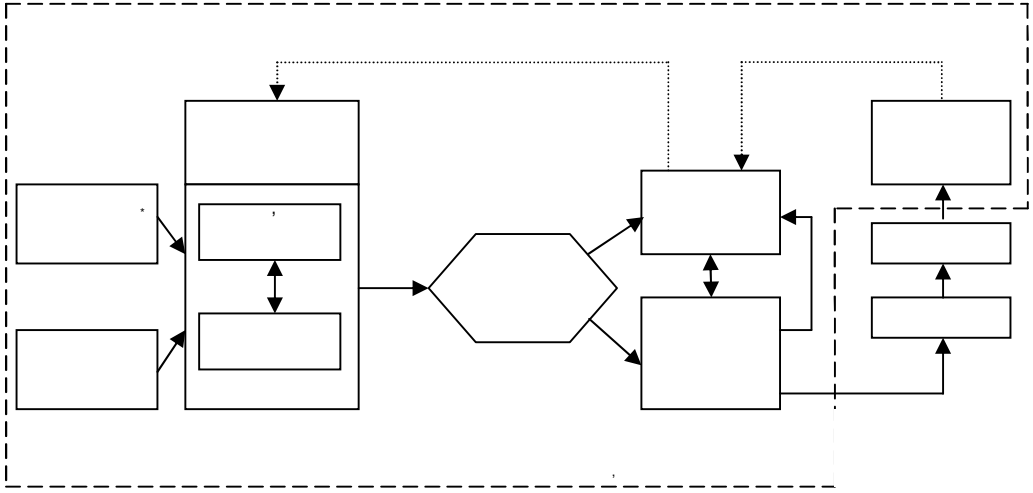

. 2.

5

. 2

" [3].

" [1].

5

7

" [3].

[1].

"PsychoLogos"⁸

6

7

⁸ <http://www.psychologos.ru>.

" [5, . 17].

[5, . 17].

" [7, . 401].

" [8, . 164].

[9, . 110].

⁹ : <http://ru.wikipedia.org> –

¹⁰

[6].
[9].

... " [10, . 9].

()

(. 3).

1) (

2) " 3".

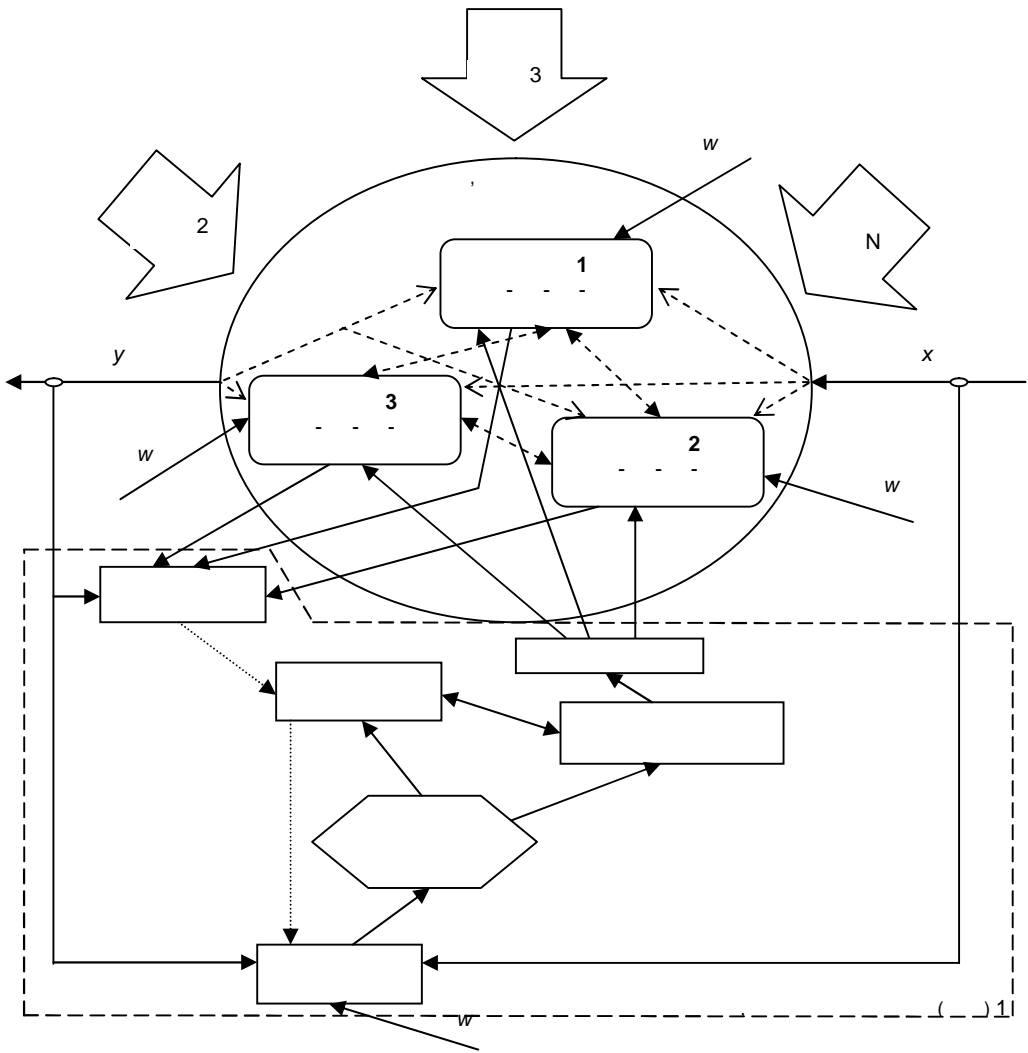

. 3. ; - ; w - ; :

1. // 1973. — 5-61

2. Anokhin P.K. *Principles of the system organization of functions*. Moscow: Nauka, 1973. pp. 5–61.
3. Anokhin P.K. *Kybernetika funktsionalnykh sistem* [Cybernetics of functional systems]. Moscow: Meditsina, 1998. 397 p.
4. Anokhin P.K. *Sistemnaya organizatsiya fiziologicheskikh funktsiy* [System organization of physiological functions]. Moscow: Nauka, 1968. pp. 5–7.
5. Pospelov D.A. *Situatsionnoye upravleniye: teoriya i praktika* [Situational management: theory and practice]. Moscow: Nauka, 1986. 286 p.
6. Anokhin P.K. *Ocherki po fiziologii funktsionalnykh sistem* [Sketches on physiology of functional systems]. Moscow: Meditsina, 1975. 448 p.
7. Smirnov E. A. *Razrabotka upravlencheskikh resheniy* [Development of administrative decisions]. Moscow: YuNITI-DANA, 2000. 271 p.
8. Mescon M., Albert M., Khedouri F. *Management*. Moscow: Delo, 1998. 799 p.
9. Podoprigora S.Ya., Podoprigora A.S. *Kratkiy psikhologicheskiy slovar* [Short psychological dictionary]. Rostov n/D: Feniks, 2012. 317 p.
10. Shcherbakov Ye.P. *Funktsionalnaya struktura voli* [Functional structure of will]. Omsk: SibGUFK Publ., 1990. 255 p.
11. Maksimova N.Ye. *Sistemnyye aspekty neyrofiziologii povedeniya* [System aspects of neurophysiology of behavior]. Moscow: Nauka, 1979. 308 p.

References

1. Anokhin P.K. *Principles of the system organization of functions*. Moscow: Nauka, 1973. pp. 5–61.
2. Anokhin P.K. *Kybernetika funktsionalnykh sistem* [Cybernetics of functional systems]. Moscow: Meditsina, 1998. 397 p.
3. Anokhin P.K. *Sistemnaya organizatsiya fiziologicheskikh funktsiy* [System organization of physiological functions]. Moscow: Nauka, 1968. pp. 5–7.
4. Pospelov D.A. *Situatsionnoye upravleniye: teoriya i praktika* [Situational management: theory and practice]. Moscow: Nauka, 1986. 286 p.
5. Anokhin P.K. *Ocherki po fiziologii funktsionalnykh sistem* [Sketches on physiology of functional systems]. Moscow: Meditsina, 1975. 448 p.
6. Smirnov E. A. *Razrabotka upravlencheskikh resheniy* [Development of administrative decisions]. Moscow: YuNITI-DANA, 2000. 271 p.
7. Mescon M., Albert M., Khedouri F. *Management*. Moscow: Delo, 1998. 799 p.
8. Podoprigora S.Ya., Podoprigora A.S. *Kratkiy psikhologicheskiy slovar* [Short psychological dictionary]. Rostov n/D: Feniks, 2012. 317 p.
9. Shcherbakov Ye.P. *Funktsionalnaya struktura voli* [Functional structure of will]. Omsk: SibGUFK Publ., 1990. 255 p.
10. Maksimova N.Ye. *Sistemnyye aspekty neyrofiziologii povedeniya* [System aspects of neurophysiology of behavior]. Moscow: Nauka, 1979. 308 p.

© . . . , 2013

Reviewer

O.A. Burbelo
 Doctor of Economic Sciences, Professor
 Luhansk State University of Internal Affairs named by E. Dedorenko, Luhansk, Ukraine