

ELECTROLYTIC CAPACITORS: DESIGN FEATURES AND PROBLEMS OF THE CHOICE

В статье рассматриваются конструкции и особенности характеристик электролитических конденсаторов различных видов. Показано, что часто возникающие проблемы в электронной аппаратуре связаны с неправильным выбором электролитических конденсаторов. Приведены рекомендации по правильному выбору электролитических конденсаторов.

In this paper, the constructions and characteristics of various kinds of electrolytic capacitors are considered. It points out that often the problems and subsequent damages in electronic equipment are coupled with a wrong choice of electrolytic capacitors. Recommendations for correct choices of electrolytic capacitors are presented.

INTRODUCTION

Recent decades have been characterized by an explosion in computer technologies and the increasing use of switching power supplies, and at the same time failures of aluminum electrolytic capacitors have become so widespread that they have been dubbed as a "capacitor plague" and have cost hundreds of millions of dollars. According to some published data, electrolytic capacitors have caused up to 70 % of all damage to computers and computerized systems. Reasons of this situation have been mythologized and an incredible story has migrated from one magazine to another and from one Internet site to another. According to the story, in 1999 (or in 2001 according to other sources) unspecified Chinese scientist working for a Japanese company engaged in the production of electrolytic capacitors, and managed to steal the secret formula of the newest electrolyte. The problem was that the formula stolen from Japanese was incomplete and now millions of electrolytic capacitors with a "terrible" water-based electrolyte have flooded the world. Within a few days or months, these capacitors absorb hydrogen from the air and explode, ruining the motherboard and any chip they are installed in. The authors of this anecdote ignored the fact that they are referring to capacitors from dozens of different manufacturers, including Japanese, and that this problem has remained for the past ten years. They "forget" about hundreds of patents on capacitor electrolyte registered in the patent collections of many countries including the United States and Russia. Moreover, they don't care that such patents include detail descriptions of the chemical composition and production technology of the electrolytes, and any chemical laboratory equipped with modern analytical equipment is able to determine the composition of the electrolyte taken from the capacitor. As you can see, the stealing of the "formula of the electrolyte" is senseless and this myth is a fake apparently invented by journalists who were not very competent in this area. But, nonetheless, the problem really exists. And not just in computers. I found hundreds of damaged electrolytic capacitors of different types in power supply modules of dozens of failed microprocessors based relay protection devices (MPD) of different types and different manufacturers. So why has this problem been aggravated in the last decade? Let's try to understand.

DESIGN FEATURES OF ALUMINUM ELECTROLYTIC CAPACITORS

First of all, let's look at the arrangement of the conventional aluminum electrolytic capacitor (fig. 1).

As we see in the drawing, the design of an electrolytic capacitor is very similar to the design of the old paper capacitors. There are two layers of foil and one layer of paper between them, rolled and covered with protective aluminum housing (fig. 1). However, despite the similar

appearance, there are fundamental differences in the design of electrolytic capacitor. The major one is that, unlike a paper capacitor, in electrolytic capacitor paper tapes are not used as the insulating material between the electrodes (plates) because they are saturated with conductive electrolyte and act as separators holding the liquid electrolyte in their pores. Between the plates there is a very thin insulating layer (its thickness is several fractions of microns) of aluminum oxide (Al_2O_3) covering the surface of the anode foil. Thanks to the small thickness of the dielectric (unattainable for capacitor paper) capacitors of this type have very large capacity (compared to paper capacitors), which is known to be inversely proportional to the distance between the plates. Increasing the area of plates (the surface area) additionally adds to the capacitance. In the electrolytic capacitors anode foil surface area is increased with electrochemical etching (before the formation of an oxide layer), after which the surface becomes somewhat rough, see fig. 2.

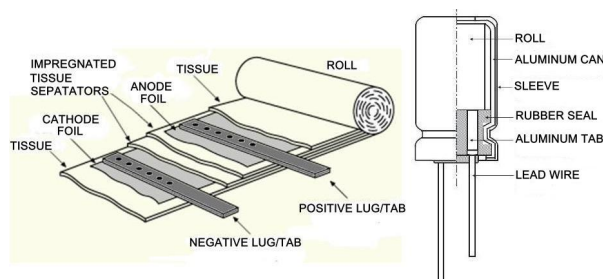

Fig. 1. Design of aluminum electrolytic capacitor

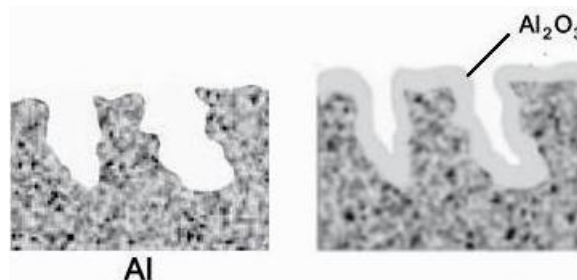

Fig. 2. Surface of anode foil after electro-etching

The greater the "roughness" the greater the area. This method allows increasing the capacitance 20-100 times. The electrolyte which is actually acting as a cathode easily penetrates into the surface roughness of the foil. In such a capacitor the cathode foil acts as a supportive electrode, connecting electrolyte to the outer negative output. Sometimes the surface is etched to improve the contact with the electrolyte and reduce the contact resistance. Aluminum oxide exists in several crystalline forms,

the most common of which is α - Al_2O_3 or corundum, known in jewelry as ruby (containing red-colored impurities) and sapphire (with blue-colored impurities). This crystal is practically insoluble in water and in acids, and is the n -type semiconductor forming the equivalent of a diode under physical contact with metals (voltage characteristic of such contact is a typical characteristic of the diode). This property of aluminum oxide determines the presence of diode D in the electrolytic capacitor equivalent circuit, see fig. 3. This diode is connected in the opposite direction and its breakdown voltage limits the operating voltage of the capacitor. The same diode conditions need to comply with the polarity of the conventional electrolytic capacitors. Inductance of aluminum electrolytic capacitors (approximately 20 to 200 nH) is primarily determined by the inductance of the foil winding, and it is usually not taken into account in the calculation of capacitor impedance, as the impedance of the capacitor is dominated by its equivalent series resistance (ESR) subjected to the resistance of the electrolyte and the outputs of the anode and cathode, including internal transient contact resistance.

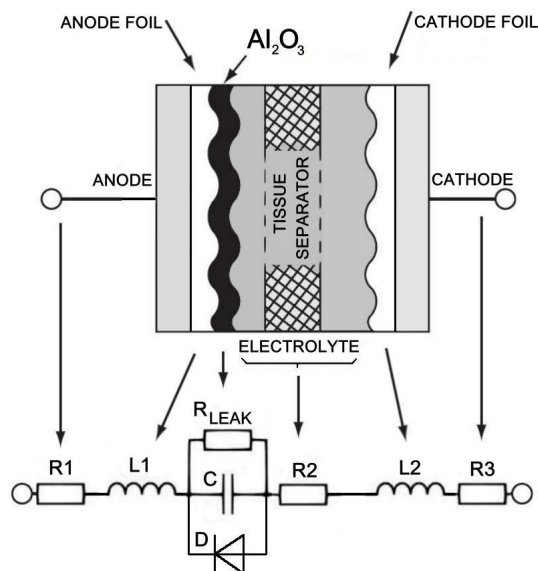

Fig. 3. Equivalent circuit of an electrolytic capacitor. R1, R3 – lead resistance on anode and cathode, including internal transient contact resistance; R2 – electrolyte resistance; L1, L2 – winding inductance of the anode and cathode foil; (R_{leak}) – impedance of leakage through defects in the aluminum oxide layer; C – capacity of the aluminum oxide layer (capacitance); D – equivalent diode formed by a layer of aluminum oxide applied on aluminum foil

However, this is true only for relatively low frequencies (below 100-1000 kHz). At high frequencies, the inductance markedly affects the impedance of the capacitor; therefore, such factors as the equivalent series inductance (ESL) should also be considered. In fact, ESL limits the maximal operating frequency of the capacitor. The greater the ESL, the lower the limit frequency at which the capacitor has any capacitance. However, since the electrolytic capacitors are not designed to operate at high frequencies, the manufacturers of these capacitors rarely publish this value in the reference documents. Aluminum oxide is a very hard and brittle material that can crack during rolling, cutting and the operation of the capacitor resulted in micro-cracks and micro-pores, which can be penetrated with conductive electrolyte increasing the leakage current. In addition, the coefficient of linear expansion of aluminum is several times greater than that of

the oxide film, so changes of the temperature at the interface results in additional internal stresses, which may also lead to defects (cracks). The lower leakage current, the better the capacitor. In good electrolytic capacitors this current does not exceed tens - hundreds micro-amps (depending on the size, temperature and applied voltage).

The chemical composition of the electrolyte must ensure recovery of the aluminum oxide layer to micro-damage. And this is not the only requirement to the electrolyte.

Modern electrolytes for capacitors are the complex multi-component mixtures of acids and salts, in which the electric current flow is supported by ions and is accompanied by electrolysis. The electrolyte determines the efficiency of the capacitor under certain nominal voltages within a certain range of operating temperatures, as well as the nominal ripple current and the life of the capacitor. An operating electrolyte has to meet various and often conflicting requirements [1]:

- high intrinsic conductivity;
- small changes in conductivity over the entire range of operating temperatures;
- good formability: forming of anode, i.e., rapid recovery of the dielectric film of aluminum oxide on the edges and micro-cracks, formed during the cutting of foil and the winding of the capacitor element on the aluminum foil anode;
- stable performance at the maximum operating temperature;
- lack of corrosion and chemical compatibility with aluminum, aluminum oxide, capacitor paper of separator;
- good wicking property of cushioning capacitor paper;
- stability of parameters during storage under normal conditions;
- low toxicity and flammability.

The main components of the electrolyte are ion formation substances (ionogens), organic and inorganic acids and their salts, but they are rarely used in their natural form. Typically, they are dissolved in a suitable solvent to produce electrolytic dissociation with the desired viscosity and formation of the electrolyte ions. Acids which can be used include monocarboxylic acids (nonane, oleic, stearic acid) and dicarboxylic acids (succinic, adipic, azelaic, sebacic, dodecane dicarboxylic acid, pentadecandioic acid), and phosphoric, boric, benzoic acid (or ammonium benzoate). Boric acid enhances the forming ability of the electrolyte. For medium- and high-voltage capacitors, lactone and amide solvents can be used as a solvents.

Electrolytes based on lactone solvents ensure high reliability and long service life of medium to high voltage capacitors, but the lower limit of operating temperature of such capacitors is limited, as a rule, to minus 55 °C.

Electrolytes based on amide solvents ensure the lower limit of the capacitor operating temperature of minus 60 °C or even lower. However, these electrolytes are not able to provide long service life for the capacitor, as they are very volatile and react with the aluminum oxide on the anode and destroy it, which leads to an increase in leakage current in the capacitor and a reduction of its service life. On the other hand, reduction of content of amide solvents and replacement of them with other solvents, which are less volatile and less aggressive to aluminum oxide, reduce low-temperature characteristics of the electrolyte, and thus of the capacitor along with the conductivity of the electrolyte. The electrolyte should not generate excessive gas (the operation of an electrolytic capacitor is accompanied with electrolysis resulting in the development of hydrogen at the cathode of the capacitor) at higher temperatures, including the top limit of the operat-

ing temperatures range. Introduction of such additives as cathode depolarizers, e.g., aromatic nitro compounds, into the electrolyte enables a reduction of gas generation. Specific conductivity depends on the residual water content in the electrolyte including water generated from the chemical interaction of its components. Addition of deionized water can increase the electrical conductivity of the electrolyte. As a result, to meet all these requirements, the electrolyte becomes a sufficiently complex chemical compound consisting of many components, such as [2]:

- Ethylene glycol;
- Alkanol;
- Acetonitrile;
- Sebacic acid;
- Dodecanoic acid;
- Ethyldiisopropylamine;
- Boric acid;
- Hypophosphorous acid;
- Ammonium hydroxide;
- Deionized water.

Finally, the parameters of the electrolyte depend on both its composition and mixing technology, while the capacitor electrical characteristics and service life largely depend on the parameters of its electrolyte.

During long-term operation of the capacitor, there are thousands of complex electrochemical reactions associated with the restoration of the oxide layer and with the corrosion attack to some internal elements, such as foil-electrode connection points. As a result of the inevitable corrosion processes, the equivalent series resistance (ESR) of the capacitor increases leading to an additional increase in temperature and greater intensification of adverse chemical and physical processes inside the capacitor, that accelerates deterioration of its parameters. The process of natural increase in ESR, i.e., natural aging of the capacitor, is rather slow (10-20 years and more). In addition to aging, in some cases, premature failure of the capacitors takes place. The main reason for this is overheating. When the capacitor temperature reaches the boiling point of the electrolyte, the internal pressure increases and a certain amount of electrolyte goes out through the drain in the bottom plug or through the special valve (in large capacity capacitors), or through the special gap at the top of the aluminum cup, see fig. 4.

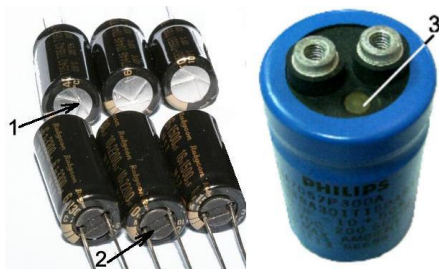

Fig. 4. Electrolyte drain paths in aluminum capacitors.
1 – special notch attenuating the bottom of an aluminum cup;
2 – plastic or rubber glass covering the plug and fixing the outputs, 3 – valve in the high-capacity capacitors

ESR rises in proportion to the loss of electrolyte, resulted in further heating-up. This positive feedback leads to a rapid capacitor failure.

Due to the loss of electrolyte capacitance in electrolytic capacitors sharply decreases, sometimes accompanied with a complete break of the internal circuit.

What's going on in electronic equipment during electrolyte drain?

First, a significant decrease in the capacitance af-

fects the normal operation of many circuits: the filtering of the variable component is impaired, voltage on sensitive circuit elements is reduced, etc. Evidence of MPD usage suggests cases of mass failure of relay types SPAC, SPAU, SPAJ (manufactured by ABB) due to a significant reduction in the capacity of a single capacitor of 100 μF in power supply unit, see fig. 5.

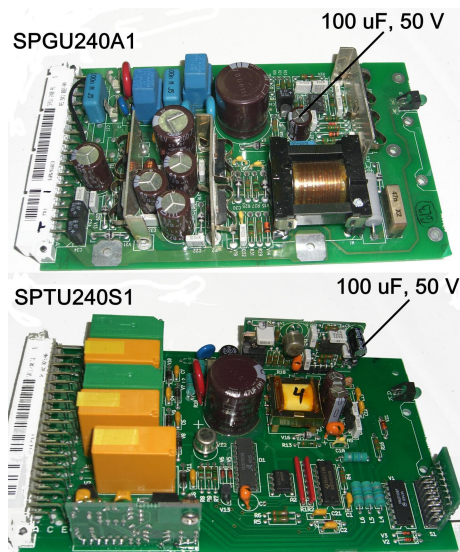

Fig. 5. Power supply units of types SPGU240A1 and SPTU240S1 of microprocessor-based protective relays type SPAC, SPAU, SPAJ (ABB)

Secondly, contact with conductive electrolyte causes short-circuiting and failure of the microelectronic components outputs. If electrolyte contacts with the power supply components which are under line voltage, the power circuit is short-circuited accompanied by intense arcing and explosive physical destruction of these elements and emission of large amount of electrically conductive soot onto adjacent components, see fig. 6.

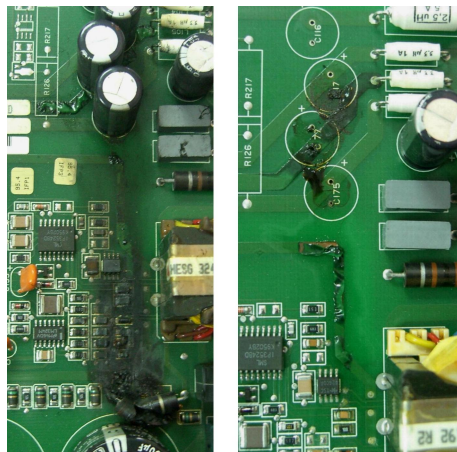

Fig. 6. Destruction of PCBs and elements due to contact with electrolyte leaked from capacitors

Furthermore, acids contained in the electrolyte rapidly destroy the varnish coating of printed circuit board (the mask) and dissolve copper tracks on PCB, see fig. 6. Sometimes, as temperature and pressure grow, the electrolytes of certain composition demonstrate faster loss due to evaporation of volatile fractions through the plug rather than due to leakage. Occasionally, usage of poor-quality electrolyte causes internal chemical reactions in the capacitor with emission of large amount of hydrogen that

leaks through the plug seal. In such cases the amount of electrolyte in the capacitor is also reduced (it partly gasifies) along with its capacitance which can go down ten-fold within 5-10 years.

What causes premature failure of aluminum capacitors? Undoubtedly, the poor quality capacitors made in violation of the processes from the poor quality materials will not last long in the equipment. However, let's dismiss the incompetent theory of a "stolen" bad recipe mentioned above. Its worthlessness has been shown above. It should be noted also that power supply units contain quite a few capacitors of the same type included in various circuits but failure occurs only in one of them (see fig. 5) or in a group included in a particular circuit (see fig. 7).

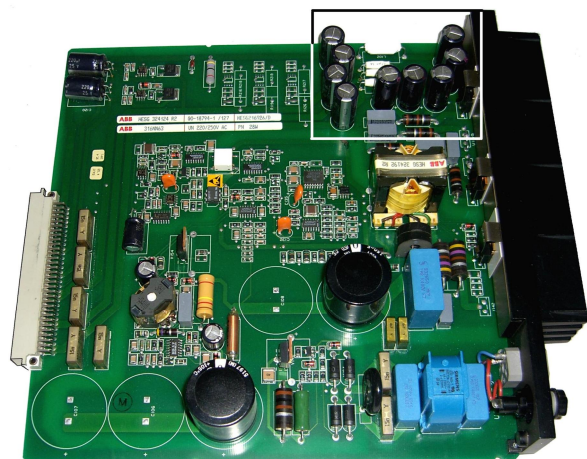

Fig. 7. Power supply type 316NN63 of microprocessor-based relays series RE * _316 (ABB). Marked group of capacitors can cause massive power failure due to leakage of electrolyte

This directly implies some other "theory" and another cause behind mass failures of capacitors. Analysis of circuits containing electrolytic capacitors which experience frequent failures shows that we are dealing here with circuits operating under high frequency voltages (used in switching power supplies). State-of-the-art high-power switching power supplies operate at frequencies of tens of kilohertz, and low power - in the range of hundreds of kilohertz [4].

Since the dielectric losses (dissipation factor – $\tan \delta$) ($\tan \delta = 2pfCR$, where $R \approx ESR$) is directly proportional to the frequency f , it is clear that additional losses occurring at these frequencies cause further heating of the electrolyte and hence an increase of pressure inside the capacitor, with all the consequences that come with it. However, as we can see from the above formula, the losses in the capacitor added to its heating are directly proportional both to the frequency and to the ESR. And this means that opting for extremely low ESR capacitors in switching power supplies may essentially reduce electrolyte heating and extend service life of capacitors as rated in the manufacturers' technical manuals for operation under maximum allowable temperature. Thus, for K50-75 type capacitors mean time to failure (MTTF) at +85°C shall be no more than 1,000 hours while reducing the temperature to +55°C results in a longer operational time of up to 10,000 hours [5].

It should be noted in this context that the method suggested by some authors for damage protection of electrolytic capacitors, such as bypassing by small-capacity ceramic capacitors, is a common misconception. At frequencies of tens to hundreds of kilohertz, impedance of small-capacity ceramic capacitors by far exceeds even the

worst electrolytic capacitor ESR. But in order to effectively protect the electrolytic capacitor from the effects of these frequencies, the protective capacitor ESR should be at least comparable to that of the capacitor to be protected. A simple calculation shows that to meet this condition, the capacity of protective capacitor at a frequency of 100 kHz should be about 5 μF , and this is characteristic of a big film capacitor with high PCB space requirements rendering this solution unacceptable.

Subject to the standard [6], technical documentation for the oxide electrolytic capacitors should reference their impedance at a certain frequency. Impedance in international practice is usually referenced at 100 kHz, typical frequency for switching power supplies. At this frequency, impedance and ESR are virtually the same. Technical manuals of Western manufacturers of low ESR oxide electrolytic capacitors may name capacitor series as follows: Low Impedance, Very Low Impedance, Ultra Low Impedance, Extremely Low Impedance. Analysis of impedance values for these capacitor series shows that actual figures correlate with the superlative degrees in their series names only on rare occasions. Therefore, such names should be regarded as an advertising gimmick only and are should not be relied upon.

Whenever you choose electrolytic capacitors to be used in switching power supply, you should check the impedance of the capacitor at a frequency of 100 kHz against the manufacturer's technical documentation. Unfortunately, quite often technical manuals of Russian manufacturers do not reference any impedance values for common general-purpose capacitors at all. For some capacitor types (such as K50-75, АДПК.673541.011 ТУ) available in 33 sizes, the impedance value is referenced only for 4 of them. And even in respect to military-purpose capacitors (index acceptance - "5"), classified in "low impedance" group (such as capacitor types K50-83, АЖЯР.673541.012 ТУ), technical manuals do reference the value of ESR and impedance, giving no frequency and temperature at which the value is guaranteed, thereby valid evaluation of these specifications cannot be made. And only for a very limited number of capacitor types produced in Russia do technical manuals clearly and accurately reflect the impedance value, making it possible to compare them with the world top capacitors, see Table. 1.

Table 1
Impedance of oxide electrolytic capacitors made by leading world manufacturers for the frequency of 100 kHz and the temperature of 20 °C

Impedance for frequency 100 kHz at temperature 20°C for capacitors	K50-53	K50-38	KZE (Nippon Chemi-Con)	HD (Nichi-con)	ZL (Rubi-con)	FM (Panasonic)
	Voronez Capacitor's Factory					
6.3 V, 1000 μF	0.4	0.3	0.053	0.053	0.053	0.038
25 V, 470 μF	0.3	0.35	0.038	0.038	0.041	0.026
50 V, 100 μF	1.0	0.6	0.074	0.074	0.12	0.061

The above data clearly show that Russian manufacturers still have a lot of room to improve the parameters of their capacitors.

Capacitor ESR can be both assessed based on manufacturers' technical manuals and measured directly by simple devices operating at the standard frequency of 100 kHz. Several models of such simple and relatively low-cost devices (USD 150 to 200) are available in the market, for example ESR60 manufactured by Peak Electronic Design (fig. 8), which can be purchased through the global distributors of electronic components, such as RS, Farnell, etc.



Fig. 8. Best-selling ESR60 type device used to measure capacitance and equivalent series resistance (ESR)

In most of commercially available devices of this type the health of capacitors may be accessed directly in the circuit without desoldering them.

It should be noted that the reliability of switching capacitors and capacitor-input filters also depends on the maximum allowable ripple current. Ripple current flowing through the electrolyte further heats it, and a condenser operating at the upper limit of the allowable temperature range has a very short life, usually up to 1,000 to 2,000 hours. When selecting an electrolytic capacitor, it is, therefore, important to consider this characteristic which usually is contained in the manufacturers' manuals. The evolution and ever wider application of microprocessor devices have uncovered another problem related to electrolytic capacitors. Today's powerful processors constitute the so-called dynamic load and operate in a pulsed high-frequency mode of consumption of rather high currents in power circuits. Traditional computer processors consume current of 5 to 10 A. In the state-of-the-art powerful processors with billions of transistors (Intel four-core processor known as Tukwila contains over two billion transistors, and their number in a new NVIDIA Fermi graphics processor already exceeds three billion) input current reaches some tens of Amperes. This means that in the processor power circuits the capacitors will be exposed to significant high-frequency charging and discharging currents, which is no better than the operating conditions in switched power supplies. Therefore, massive failures of electrolytic capacitors are not limited to the power supplies only. They occur in motherboards and processor supply circuits as well. The good news is that unlike primary power supplies, state-of-the-art high-performance microprocessors operate at very low voltages. Thus, while the first-ever microprocessors operated at a supply voltage of 5V, the latest generation microprocessors have much lower voltage requirements. Thus, Intel® Xeon® processor can operate at voltages of 1.5 to 1.33V while consuming current of up to 65A, which makes it possible to use surface-mounted low-voltage capacitors of other types (other than aluminum oxide capacitors designed for voltages of up to 600V) on the motherboard.

The most popular alternative to aluminum oxide capacitors has been presented by tantalum capacitors. Tantalum capacitors are believed to outperform aluminum ones far and away because they are the capacitors used in special-purpose military and aerospace equipment. But is this actually the case and what tantalum capacitors are like?

DESIGN FEATURES OF TANTALUM ELECTROLYTIC CAPACITORS

There are at least two large classes of tantalum capacitors: one with liquid electrolyte, and one with solid electrolyte. The main difference in design between tantalum capacitors and aluminum capacitors is their respective anode and cathode design. Unlike aluminum oxide

capacitors with anode made in the form of tape coiled into a roll, the anode in both classes of tantalum capacitors is designed in the form of a highly porous three-dimensional cylindrical tablet made of tantalum powder pellets sintered in vacuum at 1300 to 2000 degrees with the wire lead pressed in from the inside, fig. 9.

These capacitors utilized the ability of tantalum to form (by electrochemical oxidation) the oxide film on its surface – pentoxide tantalum Ta_2O_5 , a highly stable high-temperature compound resistant to acidic electrolytes and conducting current in one direction only, from the electrolyte to the metal. The electrical resistivity of pentoxide tantalum film in the non-conducting direction is very high ($7.5 \cdot 10^{12}$ Ohm-cm). This anode design determined the name of the USSR's first series of tantalum capacitors: ЭТО-1 and ЭТО-2 (ETP-1 and ETP-2 – Electrolytic Tantalum Porous – in English transcription). Their commercial production was launched in late 50s to early 60s, see fig. 10.

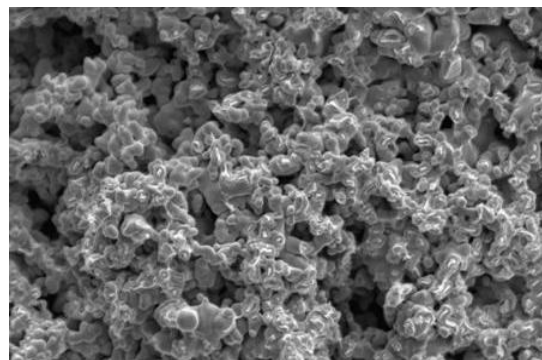

Fig. 9. The structure of the sintered tantalum pellets

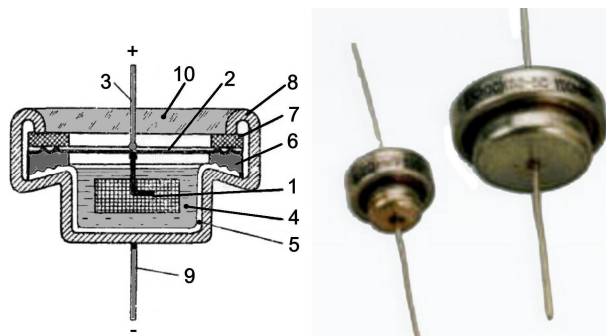

Fig. 10. The design of ETP series tantalum capacitor and its modern counterpart of K52-2 series. 1 – tantalum anode; 2 – tantalum cap; 3 – anode lead; 4 – electrolyte; 5 – inner silver shell; 6 – cushion; 7 – insulating gasket; 8 – outer steel casing; 9 – cathode lead; 10 – epoxy sealing

These capacitors proved to be so good that, despite their half-century of age, they are still produced by "Oxide" Novosibirsk plant branded K52-2 (ОЖО.464.049 TY) and with acceptance index "5" and "9" (that is, made to military and space requirements).

These capacitors usually use 35 to 38 % aqueous solution of sulfuric acid (H_2SO_4) as working electrolyte. It is this concentration of sulfuric acid that ensures its maximum conductivity and the lowest freezing point (about $-60^\circ C$).

Sulfuric acid-based electrolyte used in capacitors ensures resistivity of about 1 Ohm-cm at $20^\circ C$. Less aggressive electrolytes were suggested earlier, but they have higher resistivity, i.e., ESR: H_3PO_4 solution – 4.8 Ohm-cm, LiCl solution – 12 Ohm-cm, etc., so they are not widely used.

The presence of aggressive electrolyte such as sulfuric acid necessitates the use of double casing, an inner

thin-walled silver shell (neutral to acid) and an outer stainless steel casing providing sufficient mechanical strength. Great attention has to be paid also to the design sealing to prevent possible leakage.

Modern tantalum capacitors with liquid electrolyte are not essentially unlike the samples that were launched 50 years ago, but they have a cylindrical form, more familiar to modern capacitors, see fig. 11.

The second class of tantalum capacitors features solid electrolyte. As follows from the very name of this class of capacitors, their main difference from the above is the absence of liquid electrolyte.

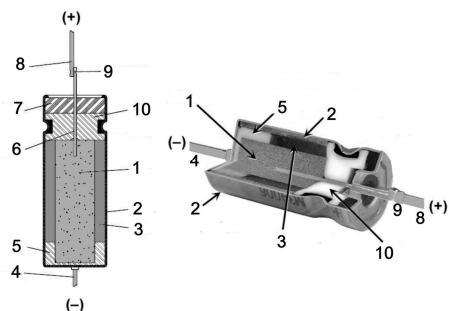

Fig. 11. The design of state-of-the-art tantalum capacitor with liquid electrolyte. 1 – tablet made of the sintered tantalum pellets, 2 – silver (silver plated) shell – cathode, 3 – electrolyte (acid), 4 – cathode lead, 5 – inside Teflon insulator 6 – anode lead made of tantalum wire, 7 – insulation plug (occasionally, glass insulator), 8 – anode lead (tin-plated nickel), 9 – welding point of anode leads. 10 – PTFE wall tube

These capacitors are also called oxide-semiconductor (solid-electrolytic) capacitors, because they use manganese dioxide (MnO_2) as a solid electrolyte known to have semiconducting properties. A layer of manganese dioxide atop the tablet made of pressed tantalum pellets with a pre-manufactured pentoxide tantalum layer is formed by keeping it in a manganese nitrate solution followed by drying at a temperature of about 250 °C. This creates a manganese dioxide layer which is used as the capacitor cathode. Mechanical and electrical contact of the outer lead with the manganese dioxide layer is achieved as follows: the manganese dioxide layer is coated with graphite; the graphite, in turn, is covered with a layer of silver to which a wire cathode lead is soldered. The cathode lead of a casing intended for surface mounting is made of an electrically conductive epoxy compound (with powdered silver filling).

Recent years have brought to life various types of tantalum capacitors with solid electrolyte differing in the composition and technology of conductive layer application to the tablet made of pressed tantalum pellets.

Most notably, solid electrolytes based on conductive polymer have proliferated, see fig. 12.

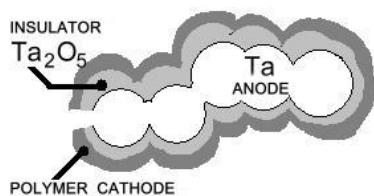

Fig. 12. The structure of solid-state tantalum capacitor with polymer electrolyte

There are several types of conductive polymers that found use in tantalum capacitors:

- Tetracyano-quinodimethane – TCNQ;

- Polyaniline – PANI;
- Polypyrrole – PPY;
- Polyethylene-dioxythiophene – PEDOT;

The latter type of polymer found the most practical use for the manufacture of capacitors (and much more).

Tantalum capacitors with solid electrolyte are free from the serious flaws of aluminum oxide capacitors such as electrolyte drying and leakage. But let's take a closer look at some of characteristics of tantalum electrolytic capacitors. Having said that tantalum capacitors certainly outperform aluminum oxide ones, it should come as some surprise to know that ESR, this critical characteristic, is by far worse in tantalum capacitors with liquid electrolyte compared to traditional aluminum capacitors, see fig. 2; that, unlike aluminum capacitors with their maximum operating voltage of up to 600V, maximum voltage of tantalum capacitors is limited to 125V (and for most types even to 50V); that tantalum capacitors fail to withstand the slightest over-voltage and even short voltage surges not exceeding their maximum allowable values and result in breakdowns with shorting the circuit they operate in. Breakdown and current flow results in strong heating-up of the capacitor and release of oxygen from manganese dioxide and taken together they cause a violent reaction of oxidation and inflammation of the capacitor which can set equipment on fire. To prevent breakdown of tantalum capacitors and to extend their life, they are used at voltages 2-4 times lower than maximum allowable ratings. Given the fact that no tantalum capacitors are available for voltages exceeding 125V (bulk production is intended for voltages of up to 50V) indicates that application of such capacitors is rather limited.

Comparison of ESR (impedance) values specified in Tables 1 and 2 for aluminum oxide and tantalum electrolytic capacitors makes against the latter.

Besides, tantalum capacitors are much more expensive as compared to aluminum ones. And even special-type tantalum capacitors claimed to be Low ESR capacitors still fall far behind the best types of aluminum oxide capacitors, see Table 3.

But why, after all, are tantalum capacitors so good, and why are these capacitor types used in military equipment?

Table 2
Typical ESR values at 100 kHz for tantalum capacitors at the temperature of 20 °C

Type and manufacturer	Nominal Voltage, V	Capacitance, μF	ESR for frequency 100 kHz, Ohm
Solid Tantalum 293D series, Vishay Intertechnology, Inc	6.3	1000	0.4
	20	100	0.5
	50	15	0.8
M3900622H0190, Cornell Dubilier	100	22	0.4

Table 3
Typical ESR values for low-impedance tantalum capacitors at 100 kHz and the temperature of 20 °C

Type and manufacturer	Nominal Voltage, V	Capacitance, μF	ESR for frequency 100 kHz, Ohm
Solid Tantalum, TRS series, Vishay Intertechnology, Inc	6.3	1000	0.1
	20	150	0.1
	50	15	0.3
CWR29 series, AVX	6	330	0.18
	20	47	0.11
	50	4.7	0.5

A positive touch to this grim picture is introduced by the fact that tantalum capacitors with polymer cathode are less flammable than capacitors containing manganese dioxide, and have lower ESR values, see fig. 13.

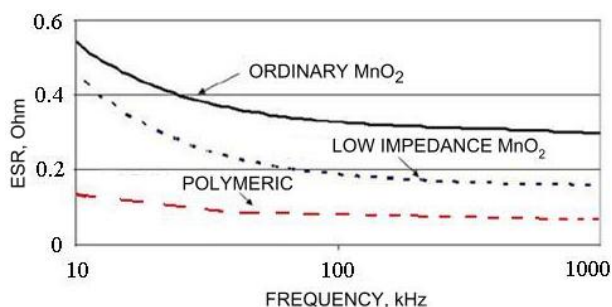

Fig. 13. Relationship between equivalent series resistance (ESR) and frequency for different types of capacitors with solid electrolyte

All types of tantalum capacitors have lower leakage currents, longer life and more importantly, much wider operating temperature range than aluminum oxide capacitors. For example, K52-18 type tantalum capacitors have minimum life of 150,000 hours at 0.6 of rated voltage and the temperature of +55 °C. Their operating temperature ranges from -60 to +125 °C and beyond (for example, +155°C for K52 series) which fully satisfies the requirements of Russian Military Standard ГOCT PB 20.39.304-98 to environmental conditions for military equipment, but has no particular importance for industrial applications, for example in digital protective relays with much narrower range of operating temperatures.

Recently high-capacity (100 µF and beyond) multi-layer ceramic capacitors have been developed that are free from many of the shortcomings typical of electrolytic capacitors, although the capacity of these capacitors is still highly dependent on temperature, they are significantly more expensive than electrolytic capacitors and are not yet widely accepted.

CONCLUSIONS AND RECOMMENDATIONS

The main characteristic of electrolytic capacitors that shall be considered for the development of new switching power supplies or repair of failed units is the equivalent series resistance (ESR) or impedance at the frequency of 100 kHz which must have minimum values.

Electrolytic capacitor protection from high-frequency component through bypassing by small-capacity ceramic capacitors is inefficient at frequencies used in switching power supplies.

State-of-the-art microprocessor operation is accompanied by the consumption of significant currents in high-frequency pulse mode, so the capacitors placed in the power circuits of microprocessors are exposed to high-frequency charging and discharging currents. For this operation mode you should also choose the capacitors with minimum ESR value.

Main types of damage in aluminum oxide electrolytic capacitors for switching power supplies are the drying up or leaking of electrolyte accompanied by dramatic decrease in capacitance, disruption of the supply unit operation and damage caused to PCB components by leaked electrolyte.

Main type of damage in tantalum capacitors for central processor units are breakdowns accompanied by shorting the circuit they operate in.

Comparative analysis of the characteristics of aluminum oxide capacitors versus tantalum capacitors has

revealed that contrary to a common misconception about the absolute qualitative supremacy of tantalum capacitors, they fall far behind aluminum capacitors in terms of such important characteristic as ESR. Besides, tantalum capacitors operate at a much narrower range of voltages which is clearly insufficient for switching power supplies, and fail to withstand even minimal overvoltage.

Commercial switching power supplies are better served by aluminum oxide electrolytic capacitors. The circuits wherein the capacitors may be exposed to high frequencies should use special types of capacitors with low ESR. In this case you should be guided by the data referenced in technical manuals or measurements made by special tools rather than by advertising names of such capacitors. For such applications, most suitable capacitors are series FM, KZE, HD, ZL.

Tantalum capacitors with solid electrolyte intended for surface-mounting have smaller dimensions than aluminum capacitors are more widely accepted and more convenient for use in CPU units. But they too should be chosen based on the minimum value of EPS if intended for microprocessor power circuits, and with 200 % to 300 % rated voltage.

In order to prevent unexpected and fatal damage to switching power supply units operating in critical electronic equipment including digital protective relays manufactured 7 to 10 years ago, it is advisable to get them examined, to identify numbers of damaged capacitors and proactively replace these capacitors in all power supply units before they fail, keeping in mind the recommended guidelines suggested in this article. While doing so, with old capacitors soldered out, their mounting locations on the printed circuit board and leaked electrolyte traces should be washed with sodium bicarbonate solution and then with distilled water and dried thoroughly.

REFERENCES

1. The working electrolyte for a capacitor, method of its preparation and aluminum capacitor with this electrolyte. Russian Patent No. 2358348, H01G9/-35, 2006, "Elekond" Plant OJSC.
2. Conductive electrolyte system with viscosity reducing co-solvents. – US Patent No. 6744619, H01G 9/42, 2004, Pacesetter, Inc.
3. Gurevich V.I. The Secondary Power Supplies: Anatomy and Application. Electrotechnical market, 2009, No. 1 (25), p. 50-54.
4. АДПК.673541.011 ТУ. К50-75 Oxide-electrolytic aluminum capacitors.
5. IEC 60384-4-1 Fixed capacitors for use in electronic equipment - Part 4-1: Blank detail specification – Fixed aluminum electrolytic capacitors with non-solid electrolyte. – Assessment level EZ.

Received 10.04.2012

Gurevich Vladimir, Ph. D., Honorable Professor
Central Electrical Laboratory of Israel Electric Corp.
POB 10, Haifa 31000, Israel
e-mail: vladimir.gurevich@gmx.net

Gurevich V.I.

Electrolytic capacitors: design features and problems of the choice.

In this paper, constructions and characteristics of various kinds of electrolytic capacitors are considered. It is shown that problems and subsequent damage in electronic equipment are often related to a wrong choice of electrolytic capacitors. Recommendations for correct choices of electrolytic capacitors are presented.

Key words – electrolytic capacitors, electronic equipment, recommendations for choices of capacitors.