

T. I. KIRILYUK, D. O. BOSIY (DNURT)

Department of Power supply of Railways, Dnepropetrovsk National University of Railway Transport named after academician V. Lazaryan, 2 Lazaryan Street, Dnepropetrovsk, Ukraine, 49010, tel.: (056) 793-19-11, e-mail: [tanya\\_kir@bigmir.net](mailto:tanya_kir@bigmir.net), [dake@i.ua](mailto:dake@i.ua), ORCID: [orcid.org/0000-0002-8580-9719](http://orcid.org/0000-0002-8580-9719)

## THE SCHEME REALIZATION FOR THE INDIRECT METERING OF ENERGY LOSSES IN A CONTACT LINE

### Introduction

The volume of energy losses in electric grids is a main indicator of efficiency of their work, visual status indicator system of power registration, efficiency of power supply organizations.

This indicator clearly shows the problems that require emergency solutions in development, reconstruction and modernization of power networks, improved methods and tools for their operation and management in improving the accuracy of electricity metering, fundraising efficiency for electricity consumed. The relative energy losses in transmission and distribution in electric networks can be considered satisfactory, if they do not exceed 4-5 %. Energy losses of 10 % can be considered the maximum acceptable in terms of process of transmission of electric power by networks.

A number of trends that adversely affect to level of losses in contact line were emerged in connection with the low investment in development and modernization of electric networks, improving their management systems regimes in accounting electricity.

Against the background of the changes taking place in the economic mechanism of energy the problem of reducing energy losses in the contact line not only lost its relevance, but rather pushed into one of the objectives of financial stability of power supply organizations.

Determination of energy losses in the contact line of electrified railways has a number of features that are primarily caused by variable size and location of the load which does not take into account a number of factors that affect the magnitude of losses [1-3]:

1. Meters of electric locomotives are often given an understated the value of consumed electricity. There are several reasons:

- inability of meters to take into account small load at the idle at prohibiting signals and stations;
- measurement errors when connecting the winding of voltage meter to the winding of transformer own needs of the electric locomotive AC;
- cases of artificial distortion of meter readings by individual driver.

2. The limits of certain railways don't meet the limits of the shoulders of service locomotives.

3. Traction and industrial consumers are powered from the traction substations. The energy consumption of industrial consumers partially takes into account by the meters of these consumers and partially calculated using the established capacity of transformers.

4. Feeders that feed a power network aren't always equipped by meters etc.

### Review of the literature

It is proved [1-5] that electricity losses in the contact line appropriately determined using indirect methods.

The energy losses in contact line are calculated by the next formula [5]:

$$\Delta W = k_l \cdot \int_0^T I_f^2(t) dt, \quad (1)$$

where  $\Delta W$  – energy losses in contact line, kW·h;

$k_l$  – energy losses coefficient;

$I_f^2(t)$  – square of feeder's current in the given time, A<sup>2</sup>;

$T$  – time of moving the train in the area, h.

This method is based on using meter of losses. This method is based on the register values of per square ampere - hours on the feeders of traction substations. The meter is located on the feeder. It measures values of per square ampere – hours in the unit of time and scales them to the energy losses using the energy losses coefficient. The first meter of energy losses for an alternating current F440P was developed on the base of meter F440 in Rostov Institute of Railway Transport [6].

The galvanic isolation on the alternating current is provided by current transformer and additionally LEM-flex converter. It is possible using the analog optocoupler for direct current measuring.

The meter of energy losses F440P can take into account losses in networks at the time of changing of load to 200% of nominal. Its error in the range changing load doesn't exceed 2 %.

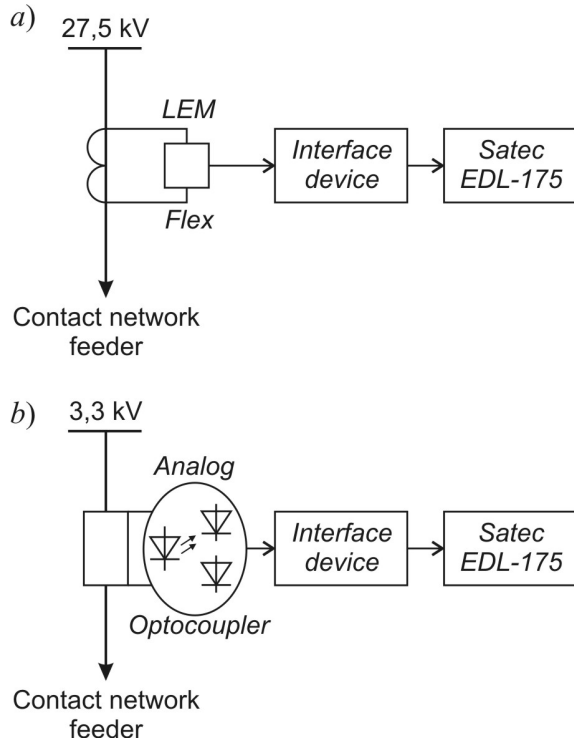

Fig. 1. The principal schemes of connecting devices for measuring losses in the contact line: a) an alternating current feeder; b) a direct current feeder

The first meter of energy losses for a direct current SKVT F607P was developed on the base of meter SKVT F607.

In electric circuit of meter of energy losses SKVT F607 were done a lot of changing. There are deleted node ban self-propelled, corrected modes transistors and circuits, power supply modernized in terms of increasing insulation strength.

Such meter of electricity losses can be realized on the modern element base, combining commercial accounting of electricity and the calculation on the energy losses based on a single device, such as Alpha Plus meter (A2) and specialized software package AlphaPlus\_LS. The latest development of Elster Metronika is Microprocessor meter alpha A1800 with the function of accounting losses (in the modification counter present letter V) and specialized software package Metercat (AlphaPlus W2.1) [7].

A detailed study of the indirect method for determining of electricity losses in the contact lines and determining the expressions for loss coefficient were done in the publications [2, 3, 5, 8-11].

**Formulation of the problem**

Meters of energy losses aren't widely used in metering of electric energy in traction substations. Besides quite a few substations have meters on the feeders of contact line. Only one type of modern meters as an additional option has a function integration of the square of the current and for the most

part this possibility in other counters unavailable. But in the distances of power supply are used modern portable analyzers of power consumption, the device particular EDL-175 by Satec company.

One of its functionality is the integration of RMS value of the current. That is calculation of ampere-hours, which are measured by Rogowski mites and matching device that converts input current and appropriate signal using a separate integrator. The output signal of the integrator is connected to the special connector main unit, which performs further calculations of the RMS value of the current and its integration in the time.

The ampere-square-hour can be determine using the described functions of the device if the convert signal between integrator of Rogowski mites and interface device.

In general, the device performs the determination of the RMS value of current for its momentary value at the period of fundamental frequency  $T$

$$I = \sqrt{\frac{1}{T} \int_0^T i^2(t) dt}$$

Transfer function of the interface device is defined that after integration squared RMS value of the current will be received. Namely a functional equation will be solved.

$$\sqrt{\frac{1}{T} \int_0^T F^2[i(t)] dt} = I^2, \tag{2}$$

where  $F[i(t)]$  – unknown function.

Assume that the desired function is equal to the square of the RMS current value that is  $F[i(t)] = i^2(t)$ . Substituting the assumption in equation (1) and check it.

$$\begin{aligned} \sqrt{\frac{1}{T} \int_0^T i^4(t) dt} &= \sqrt{\frac{1}{T} \int_0^T I_m^4 \sin^4 \omega t dt} = I_m^2 \times \\ &\times \sqrt{\frac{1}{\omega T} \left[ \frac{\cos \omega t \sin^3 \omega t}{4} - \frac{3 \sin 2\omega t}{16} - \frac{3\omega t}{8} \right]_0^T} = \\ &= \frac{\sqrt{6}}{4} I_m^2 \neq I^2. \end{aligned}$$

That assumption regarding  $F[i(t)]$  is false because the result is not equal to the square of the RMS value of the input signal.

Analyzing the previous result, we assume that the transfer function equal to product RMS and

instantaneous current value that is  $F[i(t)] = I \cdot i(t)$ . Will provide appropriate substitution in equation (2) and check it.

$$\sqrt{\frac{1}{T} \int_0^T I^2 \cdot i^2(t) dt} = \sqrt{\frac{1}{T} \int_0^T I^2 \cdot I_m^2 \sin^2 \omega t dt} = \sqrt{\frac{I^2 \cdot I_m^2}{2}} = I^2 \equiv I^2.$$

The search transfer function is equal to product the RMS and the instantaneous value of current. According to the transfer function, the structure of the interface device will have next view (fig. 2).

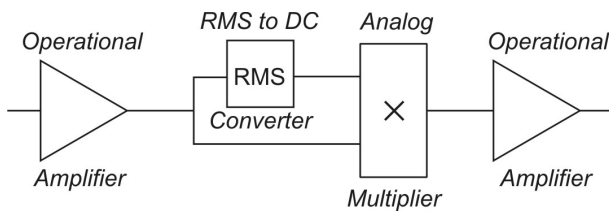

Fig. 2. Structure of the interface device

Two analog microcircuits AD637 and AD633 are used for scheme realization of the interface device. These microcircuits are done operations of determining the RMS value and multiplying signals. Operational amplifiers OP-07 are used for matching input and output signals.

Microcircuit AD633 is a functional, four-quadrant analog multiplier. It consists of a high resistance differential inputs and summing entrance. Full scaling of low-voltage output of 10 V is performed using the built-in zener diode. The nonlinearity entrance is less than 0.1%, and output

noise less than 100 mkV in the frequency band from 10 Hz to 10 kHz.

The voltage of power supply of microcircuits AD633 is from  $\pm 8$  V to  $\pm 18$  V. Inputs have negative polarity, but they are fully differential and many modifications can have a reverse polarity, or be manageable. The signals of differential inputs are converted to current. The result of the multiplication of these currents is generated by the kernel. Characteristics of built zener provides total zoom factor of 10 V. Nodal Point allows to add two or more inputs, increasing gain, convert output voltage to a current, and configure various applications.

The circuit implementation of the device for measuring of electricity losses in the contact line is proposed in view of the described above (fig. 3).

The comparing of the electricity consumption by the meters of traction substation Belgorod – Dniester and meters of trains was done for the experimental verification of obtained theoretical results. The section of Carolina - Bugaz - Belgorod – Dniester was allocated for experiment. The feeding of this section was done by the console power scheme from the feeder № 3.

Electricity losses in the contact line determined as the difference between meter of substation and the sum of electric meters of trains were  $\Delta W_{kl} = 1107$  kW·h.

Electricity losses in the contact line measured by the device (fig. 3) were  $\Delta W_{kl} = 1166,8$  kW · h. Error  $\delta$  was 5,4 %.

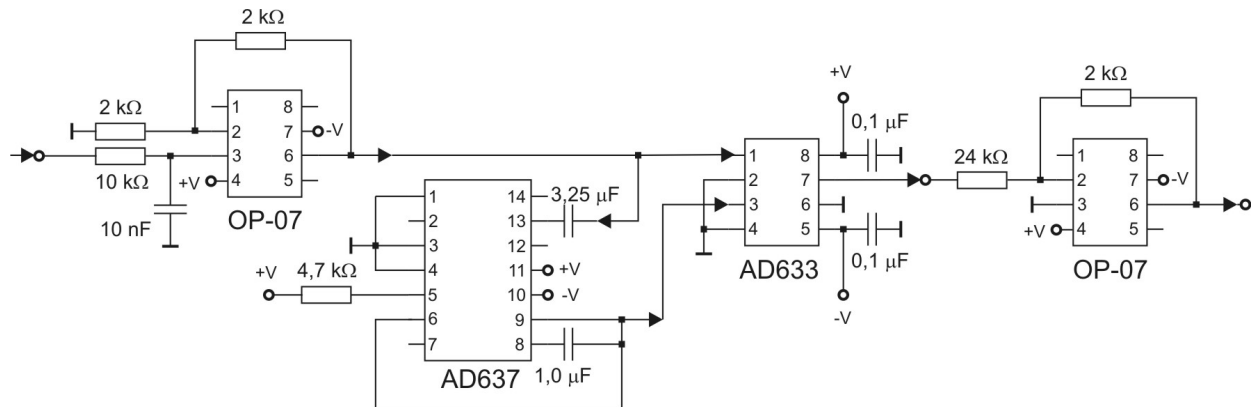

Fig. 3. The circuit implementation of the device for measuring of electricity losses in the contact line

**Conclusions**

Current converter, which in combination with a portable power analyzer can measure square of current is designed. Setting of this device with proposed energy losses coefficient allows measur-

ing the losses in the contact line in the absence of the meter.

## REFERENCES

1. Tevs A. A Sovershenstvovaniya metoda operativnykh raschetov poter moshchnosti i elektroenergii v elementakh SES s ispolzovaniem dannykh sistemy AIISKUE: Avtoref. dis [Improvement of methods of operative calculation of power losses and power in the elements of SES system using the data AIISKUE]. Omsk, 2007, 27 p.

2. Kuznetsov W. G., Bosiy D. A., Kirilyuk T. I. Oblik vtrat elektrychnoi enerhii v tiahovii merezhi nepriamym sposobom [Accounting electricity losses in traction network by the indirect method]. *Visnyk Dnipropetrovskoho natsionalnoho universytetu zaliznychnoho transportu imeni akademika V. Lazariana* [Bulletin of Dnipropetrovsk National University of Railway Transport], 2012, issue 42, pp. 103-109.

3. Maksimczuk W. F., Kuzniecov W. G., Kalasznikov K. A., Kirilyuk T. I. Badania rezerw zasilania poprzez racjonalne rozmieszczenie pociagow na odcincu [Badania rezerw zasilania poprzez racjonalne rozmieszczenie pociagow na odcincu] *Infrastruktura transport (Poland)*. [Infrastruktura transport (Poland)], 2013, issue 2, pp. 28–31.

4. Bardushko V. D. Analiz i parametricheskiy sintez sistem tyagovogo elektrosnabzheniya. Avtoreferat Diss. [Analysis and parametric synthesis of the traction power supply systems]. Irkutsk, 2001, 42 p.

5. Kirilyuk T. I. Udoskonalennja metodu kontrolju vtrat elektroenerghiji v kontaktnij merezhi elektryfikovanykh zaliznycj: Avtoref. dys. [Improving the control method of energy losses in contact line of railways]. Dnepropetrovsk, 2013, 22 p.

6. Bykadorov A. L. Uchet poter elektroenergii na elektrifitsirovannykh uchastkakh peremennogo toka [Accounting for electricity losses on electrified sections AC] *Zheleznodorozhnyy transport* [Railway transport], 1980, issue 4, pp. 57-59.

7. Alfa A1800 schetchik elektricheskoy energii trekhfaznyy mnogofunktsionalnyy: Paspport. [Alpha A1800 three-phase electric energy meter multi-function: Passport] Moscow, Elster Metronica, 2007, 35 p.

8. Bosiy D. A., Kirilyuk T. I. Udoskonalennia nepriamoho metodu obliku vtrat elektrychnoi enerhii v kontaktnii merezhi. [Improvement indirect method of accounting electricity losses in the contact system] *Vostochno-Evropeyskiy zhurnal peredovykh tekhnolohiy* [Eastern-European Journal of enterprise technologies], 2012, issue 5/8 (59), pp. 35-39.

9. Kuznetsov W. G., Bosiy D. A., Kirilyuk T. I. Vyznachennia rehlamentu zminy koefitsiienta vtrat [Determination of regulation changes of the energy losses coefficient] *Visnyk natsionalnoho tekhnichnoho universytetu «KhPI»* [Bulletin of the National Technical University «KPU»], 2013, issue 56, pp. 193-198.

10. Kirilyuk T. I. Metod vyznachennia koefitsiienta vtrat na osnovi povnoho faktornoho eksperymentu [The method of determining the energy losses coefficient on the base of full factorial experiment] *Enerhosberezhenye. Enerhetyka. Enerhoaudyt* [Energy saving. Power engineering. Energy audit], 2013, issue 11 (117), pp. 24-29.

## СПИСОК ВИКОРИСТАНИХ ДЖЕРЕЛ

1. Тевс А. А. Совершенствования метода оперативных расчётов потерь мощности и электроэнергии в элементах СЭС с использованием данных системы АИИСКУЭ: Автореф. дис....канд. техн. наук: 05.14.02 / Омский государственный технический университет. – Омск, 2007. – 27 с.

2. Кузнецов В. Г. Облік втрат електричної енергії в тяговій мережі непрямим способом. / В. Г. Кузнецов, Д. О. Босий, Т. І. Кирилюк // Вісник Дніпропетровського національного університету залізничного транспорту імені акад. В. Лазаряна – 2012 – Вип. 42. – С. 103-109.

3. Maksimczuk W. F. Badania rezerw zasilania poprzez racjonalne rozmieszczenie pociagow na odcinku / T.I. Kiriluk, K.A. Kalasznikov, W. G. Kuzniecov, W.F. Maksimczuk // *Infrastruktura transportu*. – 2013. – № 2. – С.28-32.

4. Бардушко В. Д. Анализ и параметрический синтез систем тягового электроснабжения: Автореф. дис....д-ра. техн. наук: 05.13.01 / ИрГУПС –Иркутск, 2001. – 42 с.

5. Кирилюк Т. І. Удосконалення методу контролю втрат електроенергії в контактній мережі електрифікованих залізниць: Автореф. дис....канд. техн. наук: 05.22.09 / ДНУЗТ –Дніпропетровськ, 2013. – 22 с.

6. Быкадоров А. Л. Учёт потерь электроэнергии на электрифицированных участках переменного тока / А. Л. Быкадоров // Железнодорожный транспорт. – 1980. – № 4. – С. 57-59.

7. Альфа А1800 счётчик электрической энергии трёхфазный многофункциональный: Паспорт. – М. : Эльстер Метроника, 2007. – 35 с

8. Босий Д. О. Удосконалення непрямого методу обліку втрат електричної енергії в контактній мережі / Д. О. Босий, Т. І. Кирилюк // Східно – Європейський журнал передових технологій – 2012 – № 5/8 (59)– С. 35-39.

9. Кузнецов В. Г. Визначення регламенту зміни коефіцієнта втрат / В. Г. Кузнецов, Д. О. Босий, Т. І. Кирилюк // Вісник національного технічного університету «ХПІ» – 2013 – №56 – с. 193-198.

10. Кирилюк Т. І. Метод визначення коефіцієнта втрат на основі повного факторного експерименту / Т. І. Кирилюк // Энергосбережение. Энергетика. Энергоаудит – 2013. – № 11 (117) – С. 24-29.

11. Kirilyuk T. I. Modeling the coefficient of energy losses in a contact line based on the Monte-Carlo method / T. I. Kirilyuk // *Електрифікація транспорту* – 2014. – № 8 – С. 40-48.

Received 15.05.2015.

© Kirilyuk T. I., Bosiy D. O., 2015



11. Kirilyuk T. I. Modeling the coefficient of energy losses in a contact line based on the Monte-Carlo method. *Elektryfikacija transportu* [Electrification of transport], 2014, issue 8, pp. 40-48.

Internal reviewer *Kuznetsov V. G.*

External reviewer *Denisyuk S. P.*

The volume of energy losses in electric grids is showed problems which need emergency solutions in development, reconstruction and technical modernization of power networks, improved methods and tools for their operation and management in improving the accuracy of electricity metering, fundraising efficiency for electricity consumed etc. The relative energy losses in electric networks can be considered satisfactory, if they do not exceed 4-5 %. Energy losses of 10 % can be considered the maximum acceptable in terms of process of transmission of electric power by networks.

Determination of energy losses in the contact line of electrified railways has a number of features that are primarily caused by variable size and location of the load which does not take into account a number of factors that affect the magnitude of losses. The indirect method of energy losses metering is based on the register values of per square ampere-hours on the feeders of traction substations. The meter of energy losses shows value of energy losses depending on the measured in the unit of time next factors. They are square ampere-hours, calculated energy losses coefficient, measurement period of energy losses and the square of the actual conversion coefficient.

The matching device for analog microcircuits AD637 and AD633 was used as the realization of the circuit of the device as part of the measuring complex with the analyzer power Satec EDL-175. These analog microcircuits are done determination of the RMS value and multiplication of signals with the agreement of the input and output signals by the precision operational amplifiers OP-07.

Using the developed device allowed to determine energy losses in the contact line in the real distance with an error not exceeding 5.4%.

**Keywords:** energy losses, contact line, metering, indirect method, scheme, interface device.

УДК 621.331

Т. І. КИРИЛЮК, Д. О. БОСИЙ (ДНУЗТ)

Кафедра Електропостачання залізниць, Дніпропетровський національний університет залізничного транспорту імені акад. В. Лазаряна, вул. Лазаряна 2, Дніпропетровськ, Україна, 49010, тел.: (056) 793-19-11, ел. пошта: [tanya\\_kir@bigmir.net](mailto:tanya_kir@bigmir.net), [dake@i.ua](mailto:dake@i.ua), ORCID: [orcid.org/0000-0002-8580-9719](http://orcid.org/0000-0002-8580-9719)

## СХЕМНА РЕАЛІЗАЦІЯ ПРИСТРОЮ НЕПРЯМОГО ОБЛІКУ ВТРАТ ЕЛЕКТРИЧНОЇ ЕНЕРГІЇ В КОНТАКТНІЙ МЕРЕЖІ

Обсяг втрат електроенергії в електричній мережі свідчить про проблеми, які вимагають невідкладних рішень у розвитку, реконструкції і технічному переозброєнні електричних мереж, удосконаленні методів і засобів їхньої експлуатації й керування, у підвищенні точності обліку електроенергії, ефективності збору коштів за спожиту електроенергію, тощо. Відносні втрати електроенергії в електричних мережах вважають задовільними, якщо вони не перевищують 4-5 %. Втрати на рівні 10 % вважають максимально припустимими з погляду фізики передачі електроенергії мережами.

Визначення втрат електроенергії в контактній мережі електрифікованих залізниць має ряд особливостей, які обумовлені змінним за величиною та місцезнаходженням навантаженням, що не дозволяє врахувати цілий ряд факторів. Непрямий метод виміру втрат енергії заснований на реєстрації величини ампер-квадрат-годин на фідерах тягових підстанцій. Лічильник втрат показує величину втрат в залежності від вимірних в одиницю часу ампер-квадрат-годин, розрахункового коефіцієнта втрат, періоду виміру втрат енергії та квадрату фактичного коефіцієнту перетворення.

Для схемотехнічної реалізацію пристрою у складі вимірювального комплексу з аналізатором потужності Satec EDL-175 застосовано пристрій узгодження на аналогових мікросхемах AD637 та AD633, які виконують визначення діючого значення та множення сигналів з узгодженням вхідного та вихідного сигналу прецизійними операційними підсилювачами OP-07.

Застосування розробленого пристрою дозволило визначити втрати на реальній ділянці з похибкою не більше 5,4 %.

**Ключові слова:** втрати електроенергії, контактна мережа, облік, непрямий метод, схема, пристрій узгодження.

Внутрішній рецензент *Кузнецов В. Г.*

Зовнішній рецензент *Денисюк С. П.*

УДК 621.331

Т. И. КИРИЛЮК, Д. А. БОСЬЙ (ДНУЖТ)

Кафедра Электроснабжение железных дорог, Днепропетровский национальный университет железнодорожного транспорта имени акад. В. Лазаряна, ул. Лазаряна 2, Днепропетровск, Украина, 49010, тел.: (056) 793-19-11, эл. почта: [tanya\\_kir@bigmir.net](mailto:tanya_kir@bigmir.net), [dake@i.ua](mailto:dake@i.ua), ORCID: [orcid.org/0000-0002-8580-9719](http://orcid.org/0000-0002-8580-9719)

## СХЕМНАЯ РЕАЛИЗАЦИЯ УСТРОЙСТВА НЕПРЯМОГО УЧЕТА ПОТЕРЬ ЭЛЕКТРИЧЕСКОЙ ЭНЕРГИИ В КОНТАКТНОЙ СЕТИ

Объемы потерь электрической энергии в электрических сетях свидетельствуют о проблемах, которые требуют неотлагательных решений в развитии, реконструкции и техническом переоснащении электрических сетей, усовершенствовании методов и средств их эксплуатации и управления, повышении точности учета электроэнергии, эффективности сбора средств за потребленную электроэнергию, и т.п. Относительные потери электроэнергии в электрических сетях считают удовлетворительными, если они не превышают 4-5 %. Потери на уровне 10 % считают максимально допустимыми с точки зрения физики передачи электроэнергии сетями.

Определение потерь электроэнергии в контактной сети электрифицированных железных дорог имеет ряд особенностей, которые обусловлены переменной по величине и местоположению нагрузке, которые не позволяют учесть целый ряд факторов. Непрямой метод измерения потерь электроэнергии основан на регистрации величины ампер-квадрат-часов на фидерах тяговых подстанций. Счетчик потерь показывает величину потерь в зависимости от измеренных в единице времени ампер-квадрат-часов, расчетного коэффициента потерь, периода измерения потерь электроэнергии и квадрата фактического коэффициента преобразования.

В качестве схемотехнической реализации устройства в составе измерительного комплекса с анализатором мощности Satec EDL-175 применено устройство согласования на аналоговых микросхемах AD637 и AD633, которые выполняют определение действующего значения и умножение сигналов с согласованием входного и выходного сигнала прецизионными операционными усилителями ОР-07.

Применение разработанного устройства позволило определить потери на реальном участке с ошибкой не более 5,4 %.

**Ключевые слова:** потери электроэнергии, контактная сеть, учет, не прямой метод, схема, устройство согласования.

Внутренний рецензент *Кузнецов В. Г.*

Внешний рецензент *Денисюк С. П.*