

UDC 62-529

I. Z. Maslov

### DREDGER'S SLURRY DISCHARGE PROCESS AUTOMATIZATION

*There are considered main directions for dredgers production output arising. As a single direction there was distinguished a process of slurry unloading. The system was created as a combination of connected between each other single pipelines, which along their lines have a number of washout discharge holes. Automatic system for soil washout during its discharge was considered. In details has been described wireless network for controlling discharge scheme. For high quality supplying during soil washout inside the cargo tank of the ship there has been offered the usage of complex pipeline with the system of automatically directed electromagnetic valves. On the base of empirical laws there has been formulated scheme of the valve control algorithm.*

**Keywords:** dredger, modernization of transportation process, tank discharge technology, washout hole, pipeline section, directed jet, pressure in the system, slurry, cyclic process, washout process automating, complex pipeline, primary pressure and flow-rate units, wireless technology WirelessHART, network automatic functioning, network self-tuning, production

И. З. Маслов

### АВТОМАТИЗАЦИЯ ПРОЦЕССА РАЗГРУЗКИ ГРУНТА НА ЗЕМСНАРЯДАХ

*Показаны основные пути повышения производительности земснарядов. Как отдельное направление выделен процесс выгрузки пульпы. Рассмотрена автоматизированная система размыва грунта для выгрузки пульпы, которая представляет собой комбинацию соединенных между собой трубопроводов, содержащих серию размывочных отверстий. Детально описана беспроводная сеть схемы управления разгрузкой грунта. Для обеспечения качества размыва грунта в трюме судна предложено использование сложного трубопровода с системой автоматически регулируемых электромагнитных клапанов. На основании эмпирических законов сформулирована схема алгоритма управления клапаном.*

**Ключевые слова:** земснаряд, модернизация процесса транспортирования, технология очистки трюмов, направленная струя, давление в системе, пульпа, циклический процесс, автоматизация процесса размыва грунта, сложный трубопровод, первичные датчики расхода и давления, беспроводная технология WirelessHART, автоматическое функционирование сети, самонастройка сети, производительность

I. Z. Maslov

### АВТОМАТИЗАЦІЯ ПРОЦЕСУ РОЗВАНТАЖЕННЯ ГРУНТУ НА ЗЕМСНАРЯДАХ

*Показано головні напрямки підвищення продуктивності земснарядів. Як окремий напрямок виділено процес розвантаження пульпи. Ця автоматизована система є комбінація поєднаних між собою трубопроводів, що містять серію розмивочних отворів. Розглянуто автоматизовану систему розмивання ґрунту для розвантаження пульпи. Детально описано бездротову мережу схеми управління розвантаженням ґрунту. Для забезпечення якості розмивання ґрунту в трюмі судна запропоновано використання складного трубопроводу з системою автоматично регульованих електромагнітних клапанів. На основі емпіричних законів сформульовано схему алгоритму управління клапаном.*

**Ключові слова:** земснаряд, модернізація процесу транспортування, технологія очищення трюмів, направлений струмінь, тиск у системі, пульпа, циклічний процес, автоматизація процесу розмиву ґрунту, складний трубопровід, первісні датчики витрати і тиску, бездротова технологія WirelessHART, автоматичне функціонування мережі, самонастроювання мережі, продуктивність

#### I. Introduction

Productivity improving for any vessel from the dredging fleet is a very actual problem. Between working economic indicators and quantity of the transported soil exists a direct relationship and precisely it determines the level of dredger's efficiency [2].

Production output can be enlarged by the implementation of two directions [10]. The first one corresponds to the technological stage,

associated with the extraction of the soil. Principally this direction is determined by:

- main technological parameters of the vessel (used equipment, availability of an additional booster pump, etc.);
- training level of the operator governing the dredging;
- type of the soil which is sucked from the bottom of developed area.

The second direction is connected with the slurry discharging. Unloading speed at the storage area shortens the ship's downtime, but

© Maslov I.Z., 2013

from a technological point of view is more complex, than the process of soil extraction. Main problems in such a case are associated with the soil compaction; it's sticking to the tank walls and the lack of special devices for soil discharge.

The technologies which are used for slurry discharge and the level of their automation define as well as dumping speed and a level of technical complexity of this operation realization. Modernization of technologies, that are used for transportation and overloading of dredged soil during its proper use can lead to a significant reduction in vessel's downtime during soil discharge and will let to unload all the transported soil without ballast residues.

## II. Materials of research

The main direction of the works, connected with automation of the soil discharge system from the vessel's tanks must provide continuous implementation of the cyclic process – "washout – discharge from the vessel's tanks – transporting or dumping by means of hydraulic systems use".

During the study there was developed a new system for soil washout within the working space of the vessel's tank [5, 7]. It was created as a combination of connected pipelines,

comprising along their lengths a series of washout holes. Its schematic diagram is shown in Fig. 1.

The maximum size of the system corresponds to the cross-section area of the tank bottom. By means of pump 2 water is supplied to washout pipelines 5. Due to the pressure, generated in the system, the water, through the washout holes 6 as directed jets falls down onto the surface of soil in the tank. At the same time, because of the automating of the water flow process each section of the complex pipeline 5 can be switched off by means of automatically controlled operation of electromagnetic valves 3.

The proposed technology for tank cleaning of dredger's fleet ships from the soil can significantly improve the quality and productivity of the discharge process [7, 8]. From the other hand, the existing technological conditions on dredgers, namely: large volumes of tanks, the inability of visual monitoring for all stages of the washout plant working, require the use of control-measuring equipment to automate the process of slurry discharge. In such a case, due to automating of the washout process it becomes possible to reduce down the cost of the discharge process [5, 7, 8].

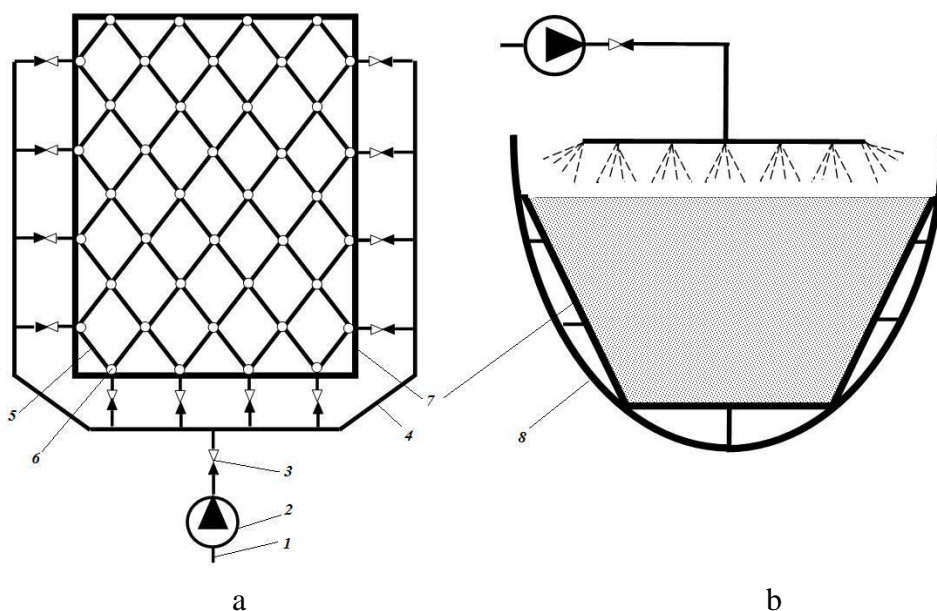

Fig. 1. Scheme of washout system a – top view, b – lateral view:  
1 – feed pipeline; 2 – pump; 3 – electromagnetic valve; 4 – loop pipeline circuit;  
5 – washout pipeline; 6 – washout hole; 7 – vessel's tank; 8 – vessel's hull

During the investigation works, there was developed control system for soil discharge, which allows to automate:

- check up the height level of the complex pipeline 5 (see Fig.1) in relation to the tank bottom;
- check up the pressure and flow-rate of washout water in the system of automatically controlled electromagnetic valves 3;
- regulation of the frequency and opening duration for all valves of the soil wash out system.

For implementation of all these functions for soil discharge technological process there was developed a system of automated control. It includes: pressure sensors, flow meters, level meters.

For high quality providing for all controlled measuring parameters in the soil washout system main part of sensors must be installed directly on the movable part of the circuit pipeline. Depending on the type of dredger the displacement of the washout pipeline 5 (see Fig. 1) is possible to the considerable distances, which ones in the main are determined by the dimensions of the vessel's tank and the speed rate of soil pulp discharge [11]. In these conditions for reliable exchange of information in the control system must be used modern industrial information systems, networks and protocols, with high reliability, speed, and noise immunity. To these requirements more over answer modern wireless industrial technologies [3].

One of the most advanced technologies for wireless communication in technological process control systems in manufacturing is a Wireless HART technology [4]. Up to present time in the world were set and running more than 30 million HART–devices and HART technology is the most common field communication protocol for smart metering devices. Because of the optional wireless features all the benefits provided by this powerful technology to remain productive factor increasing the competitiveness of technology solutions based on it.

For use in ship conditions the most important feature of Wireless HART technology is the automatic operation of the sensors network that provide:

- self-organization and self-healing network;
- a continuously acting defense;
- self-tuning while replacement or addition of new devices;
- adapting to changes in the operating network infrastructure.

*Wireless*HART technology provides reliability of data through transmitting at the level of 99,9 % under all operating conditions, which is significant in terms of the ship operation. HART–Protocol, is one of the best industrial protocols for information exchange in networks of process control systems. It provides high reliability, speed, safety, conflict-free and noise immunity. Most of the modern manufacturers of control-measurement equipment produce sensors and metering devices that have built-in hardware support for this protocol.

During development of the automated slurry discharge control system have been proposed to use equipment and technologies of the Emerson company. It offers solutions, which are answering to the highest requirements, standards and operating conditions. Emerson's equipment is widely used in modern technical fleet, which makes relatively easy to integrate considered system into the existing infrastructure of marine equipments. Most of the modern Emerson's sensors and devices have built-in wireless HART interface. By means of the use of wireless HART communicators that integrate wired devices to wireless networks it is possible to use equipment of the older generation too [13]. The scheme of self-tuning wireless sensor network, that is a part of the control system is shown in Fig. 2.

The network is based on compliant with IEEE 802.15.4 standard radio transmitters which operate in the industrial, scientific and medical band equals 2,4 GHz. They are using a technology of wideband signal with direct sequence and channel's switching for providing the communication security and reliability, as well as multystation synchronized access technology with time division multiplexing (TDMA) and controllable delay for communication between network devices.

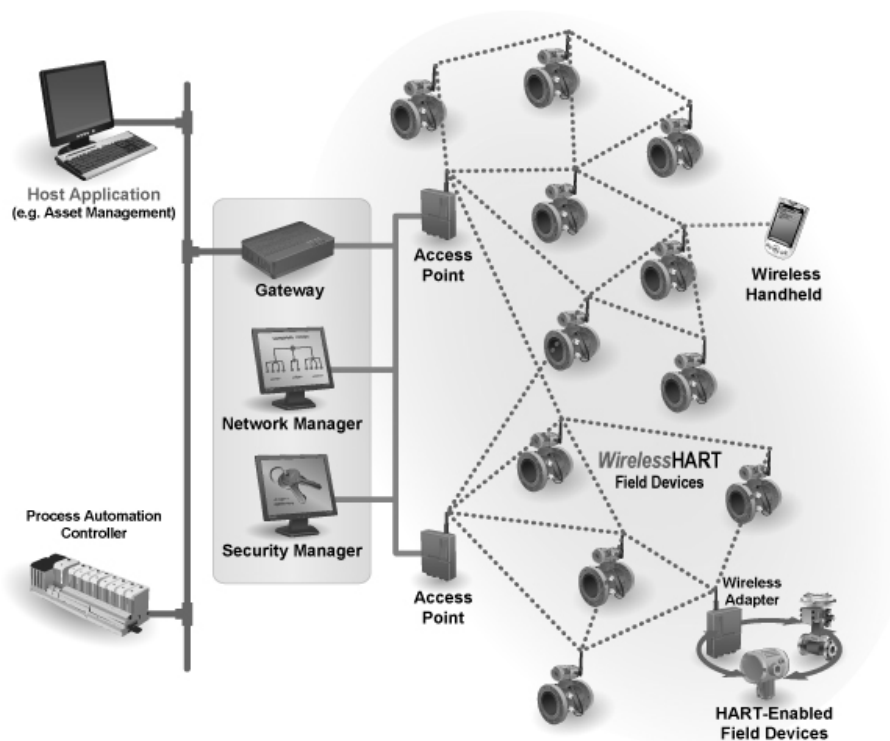

Fig. 2. The scheme of wireless network for the soil discharge system

In development of automating control management system of slurry unloading there was used the principle of routers devices [13]. In this case, any of the controlled electromagnetic valves can work as a router for communications from other adjacent valves. In other words, in case of necessity to disable any of the complex pipeline sections 5 (see Figure 1) for controlled electromagnetic valve there is no need to apply directly to the gate-way. The desired signal is transmitted to the nearest neighbor device. This principle extends the spread area of a network and provides redundant data transmitting channels for reliability improvement. Applied mesh network scheme makes it easy to add and move additional devices too. The unit is always connected, when it is within operating zone of other devices in the network.

One of the main functions in the soil discharge process control system is the regulation of the frequency and operation duration for electromagnetic valves [6]. For valve working range diapason presetting there was used empirical law of valve operation regulation [1].

$$f = \frac{k_1 h}{Q_1(P_2 - P_1)}, \quad (1)$$

$$t = \frac{k_2 h}{P_2 Q_2}, \quad (2)$$

where  $f$  – switching frequency of electromagnetic valve for arbitrary considered contour 4 or washout 5 (see Fig. 1) pipeline section;  $h$  – the height of the complex pipeline location in relation to the bottom of the vessel's tank;  $Q_1$  – flow-rate of the discharged slurry;  $Q_2$  – water flow-rate in feeding pipeline 1;  $P_1, P_2$  – operating pressure immediately after the electromagnetic valves 3 and washout holes 6;  $t$  – duration of the jet's work at the outlet of the washout holes;  $k_1, k_2$  – factors, determined by empirical way in dependence of the used type of valve construction.

Scheme of the algorithm for valve control presented in Fig. 3. The control algorithm is implemented in the application Host Application and in software Process Automation Controller, both of which are represented in a schematic (Fig. 2).

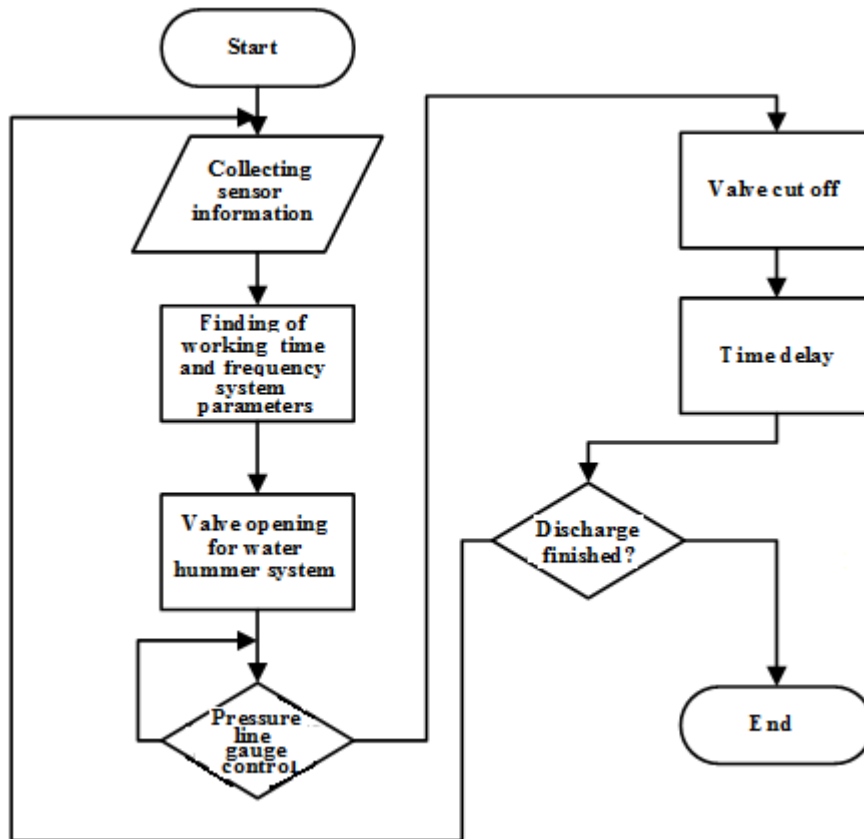

Fig. 3. Scheme of the algorithm for valve control

To provide working flexibility of the network under different conditions of the dredger's operation WirelessHART standard supports a few data transfer modes, including:

- a one-way publishing of process and control parameter's values;
- instant notification at the exclusion;
- special request/response and the transfer of large data sets with automatic segmentation.

All of these features allow to customize the data transmission according to the production requirements of the real process of slurry unloading. As a result – it is possible to reduce energy consumption, to cut down the flow-rate of water used and the most significant to descend the vessel's downtime [9].

Developed automated network for soil washout gives an ability to provide dynamical control of all parameters of primary sensors, as well as from a stationary operator's PC and from mobile managing terminal. During plant operation, it is possible to connect additional control and diagnostic components: network monitor, security server, etc.

### III. Conclusions

1. The main trend in works on the system automation of slurry discharge from the dredger's tanks must ensure continuous implementation of the cyclic process – "washout – discharge from the vessel's tanks – transporting or dumping by means of hydraulic systems use". It can be stated, that the automation of the slurry discharge process from the vessel's tanks is practically the only way to reduce downtime and descend the cost of tank cargo unloading.

2. To ensure a high quality of measured parameter's control in the system of soil discharge it is necessary to use wireless technology Wireless HART. In case of its usage for the automatic functioning of the sensor's network will be provided self-organization and self-restoring of the network, self-tuning while the structural scheme is changing and adaptation to the changes in the operating network infrastructure.

3. Using the principle of router devices extends spread area of the network and provides redundant data transmitting channels for the

reliability improvement. In such a case it is possible to add and move additional devices without damage for the performance of slurry discharge system.

#### References

1. Cherniy, V. P. Hydraulic regulators / V. P. Cherniy – Moscow–Leningrad : "Energy", 1966. 144 p. [in Russian].

2. Donskikh, D. F. Wear resistance of steels and suction-tube dredger members hardened by surface electrolysis borating during abrasive wear / D. F. Donskikh, Y. E. Ezhov // Journal of Machinery Manufacture and Reliability. August 2011. – Vol. 40. – Iss. 4. – P. 355–358.

3. Gaikovich, G. F. Wireless communication networks in industrial automation / G. F. Gaikovich // Electronic components, – 2007. – N 10. – 64 p. [in Russian].

4. Gaikovich, G. F. New wireless networking standards for industrial automation / G. F. Gaikovich // Electronic components, – 2008. – N 2. – 75 p. [in Russian].

5. Kolegaev, M. A. Design features of the ship's systems using impulse pressure drops / M. A. Kolegaev, S. V. Zuev, A. V. Malahov, I. Z. Maslov, F. A. Bendeberya // Ship Power Plants: Scientific and technical magazine. – 2012 – Odessa : ONMA/ – N 30. – P. 28 – 37 [in Russian].

6. Kondratieva, T. F. Safety valves / T. F. Kondratieva – Leningrad : Mashinostroenie, – 1976. – 232 p. [in Russian].

7. Malahov, A. V. Hydroelasticity of ship's system for soil washout [ A. V. Malahov, F. A. Bendeberya, M. A. Kolegaev, S. V. Zuev, I. Z. Maslov ] // Scientific papers magazine SWorld. Proceedings of the international scientific-practical conference "Modern problems and their solutions in the science, transport, manufacturing and education 2012." Odessa :– Iss. 4. Vol. 2. – 2012 Kuprienko – P.107–109 [in Russian].

8. Malahov, A. V. Main aspects of hydroelasticity of ship's pipelines and cables [A. V. Malahov, F. A. Bendeberya, M. A. Kolegaev, S. V. Zuev, I. Z. Maslov] // Scientific papers magazine SWorld. Proceedings of the international scientific-practical conference "Modern trends in theoretical and applied

research in 2013." – Odessa :– Iss. 1. – Vol. 1. – 2013. Kuprienko, – P.115 – 118 [in Russian].

9. Michael H. de Freitas. Withdrawal of Support by Surface Excavations / Michael H. de Freitas. // Engineering Geology. – 2009. – P. 247–294 [in English].

10. Per Bruun. Dredging of Coastal Environments / Per Bruun // Encyclopedia of Coastal Science. Encyclopedia of Earth Science Series. – 2005. P. 390 – 395 [in English].

11. Svetlitskiy, V. A. Mechanics of pipelines and cables / V. A. Svetlitskiy – Moscow : Mashinostroenie, 1982. – 280 p. [in Russian].

12. WirelessHART. How does it work. - HART Communication Foundation, 2013. [Electronic resource] – Access mode: [http://ru.hartcomm.org/protocol/wihart/wireless\\_how\\_it\\_works.html](http://ru.hartcomm.org/protocol/wihart/wireless_how_it_works.html) – 15.02.2013.

13. Zhang Yu-hua, Jiang Jian-guo. Dynamic Positioning Control System of the Dredger / Zhang Yu-hua, Jiang Jian-guo // Electrical, Information Engineering and Mechatronics, 2011. Lecture Notes in Electrical Engineering. – 2012. –Vol. 138. – P. 1489 – 1495.

Received 10.04.2013



Maslov, Igor Z.  
Graduate student of  
marine auxiliary  
machinery Odessa Na-  
tional Maritime Acad-  
emy,  
Didrikhsona st. 8,  
Odessa, Ukraine,  
65000.  
tel. (048) 777-57-74