

62.83

• •
• •

• • Smotrov, PhD.,
V. V. Subbotin

RECUPERATOR OF THE ELECTRIC DRIVE OF THE LIFT

Abstract. *In this paper attention is focused on improving the energy performance of elevators, the basic ways of using the recuperated energy. Author proposes the use of a bidirectional DC / DC converter that plugs directly to the complete drive, describes a possible algorithm of the proposed device. Also shows the experimental data from a study of consumption of active energy electric elevator with contactor control.*

Keywords: *specific energy consumption, electric vehicles, electric drive, motor-wheel, energy, energy loss, optimum, direct current to direct current converter, traffic conditions, efficiency*

• •
• •

[1] –

7 500 Siemens (), / .
 ABB (), Shneider Electric (),
 « - » () PCE-360 -
 - , [1] .
 1,0/0,25 / . -
 . - .1. -
 , - , -
 - 1 / , -
 - , (. 2,). -
 - , [6] , -
 100000 100 , -
 , 2 150 (. 2,). 300 – 400 (-
 . , 1600 . 300 – 400 (-
 . -). -
 . - -
 / . -
 . () -
 . () (-
 , -) – . -
 . [1] -
 , -040-6 -
 , 400 -
 , - -
 , 30 -
 - 024, OMRON L7 WARISPEED, -
 , -0,4 (24,5), -
 - 100L-4/16G 7,5 , -
 1380/325 -1. -
 - 1,6 / . -
 , - (3; 4; 5 -
 - 6). . 3, -
 300 . 100- 150- , . 3, – 310-
 , - 380- , -
 - -
 82-6/24, 7/1,75 , 1000/250 . -

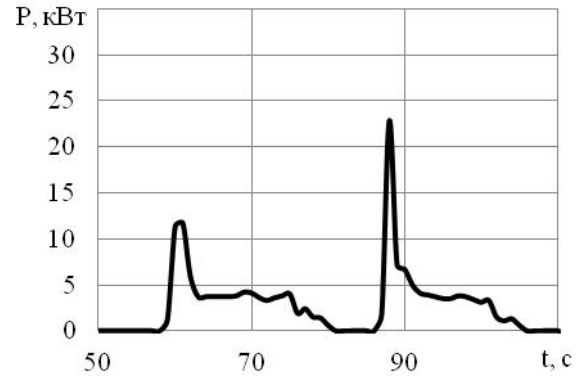
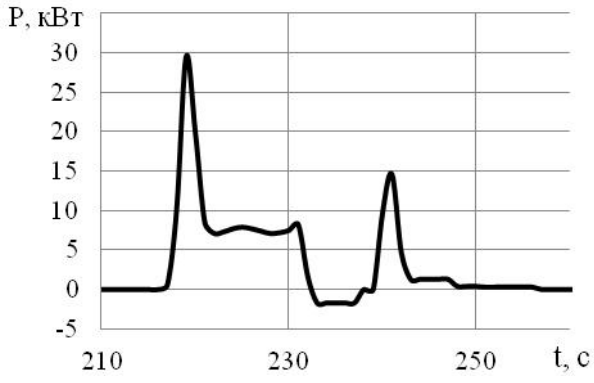

. 1.

()

()

:

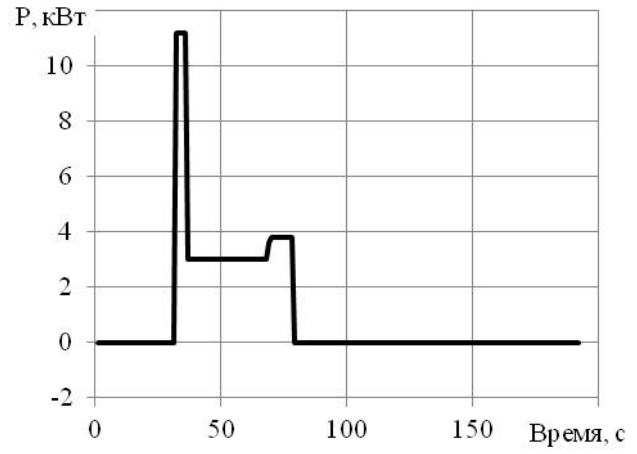
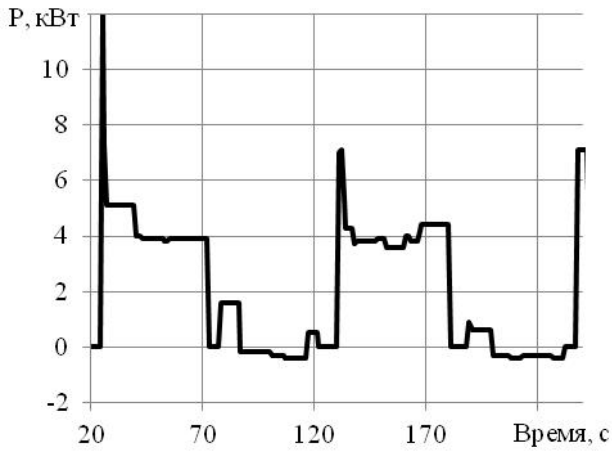

. 2.

()

()

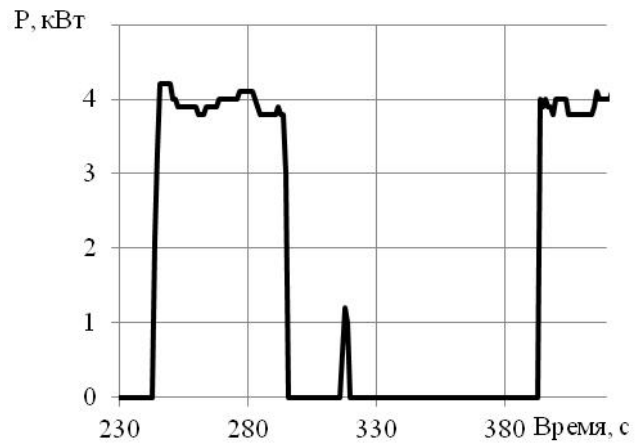
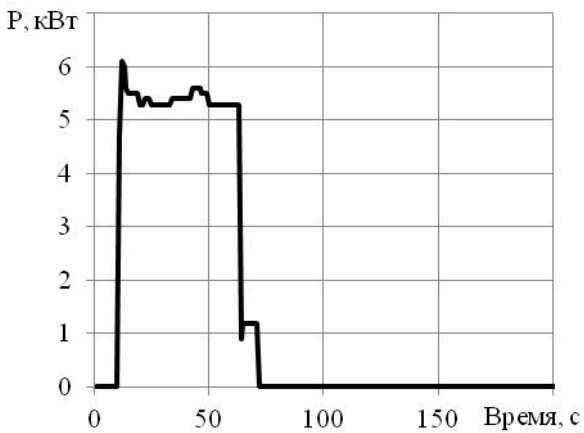

. 3.

-040-6

()

()

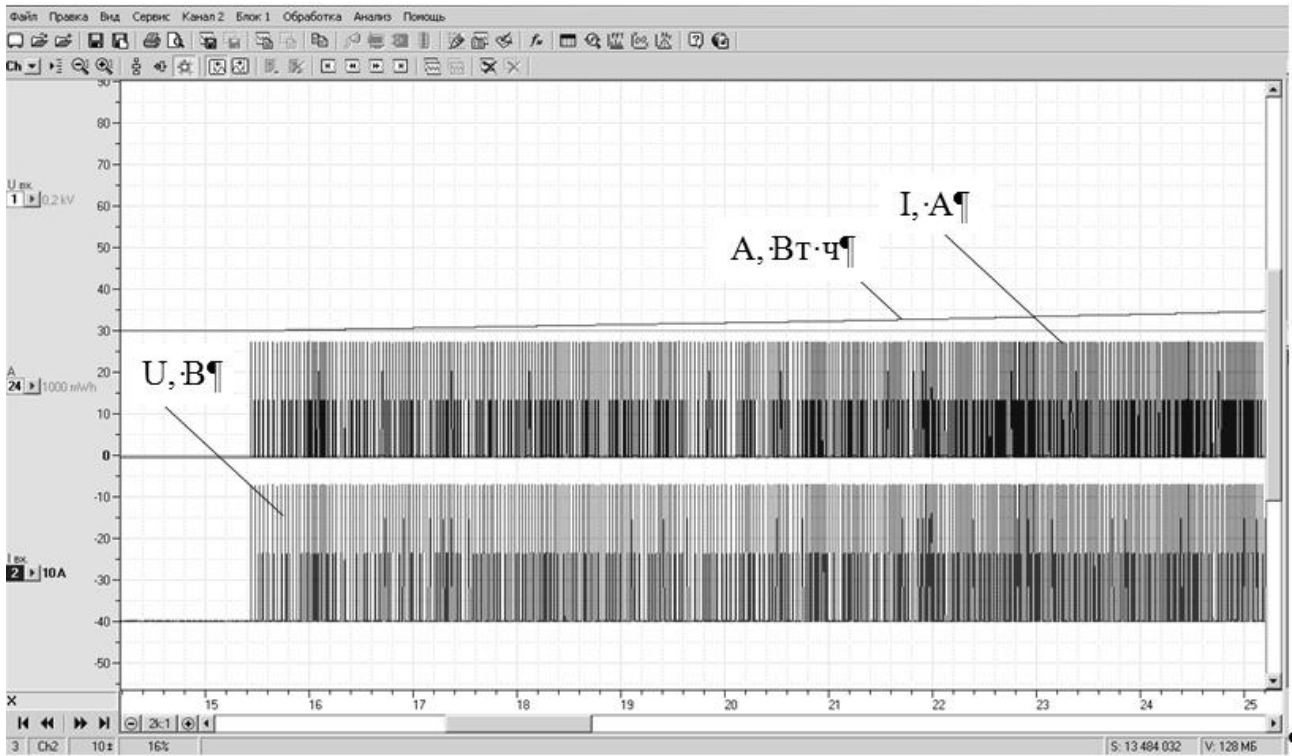

.4.

-040-6

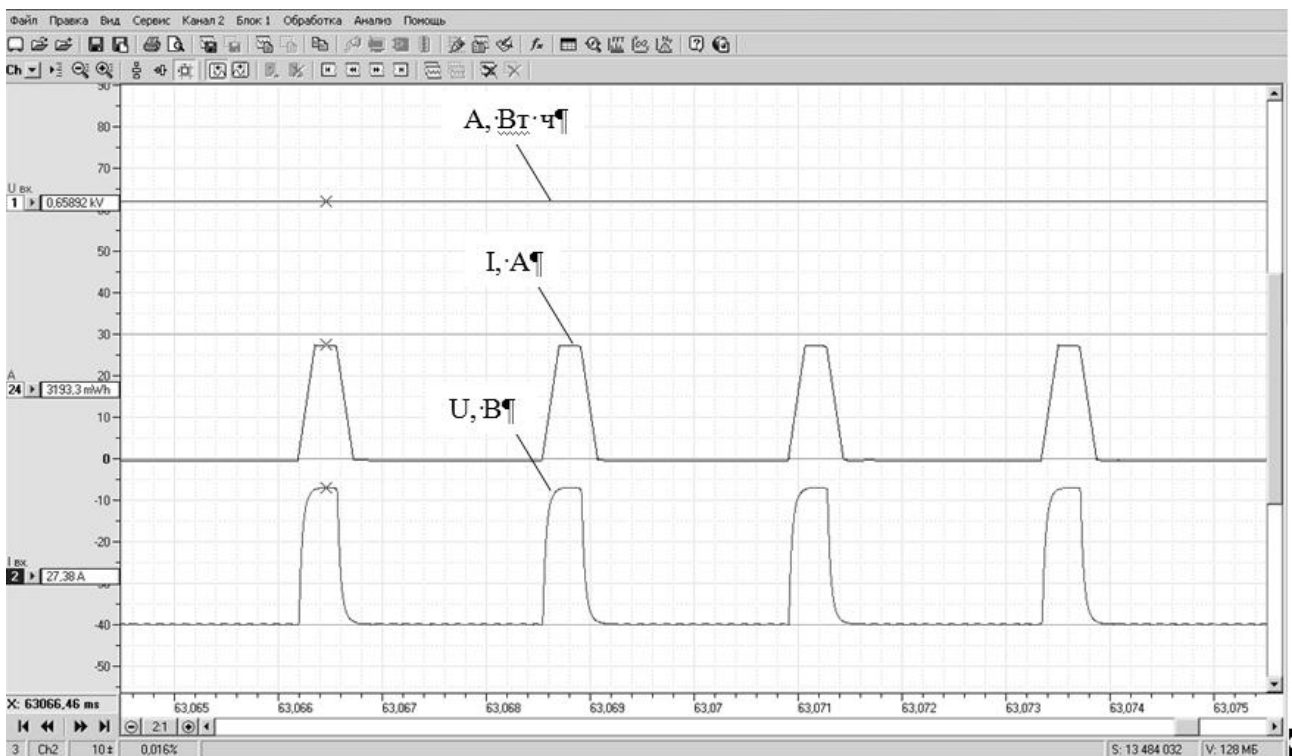

.5.

()

-040-6

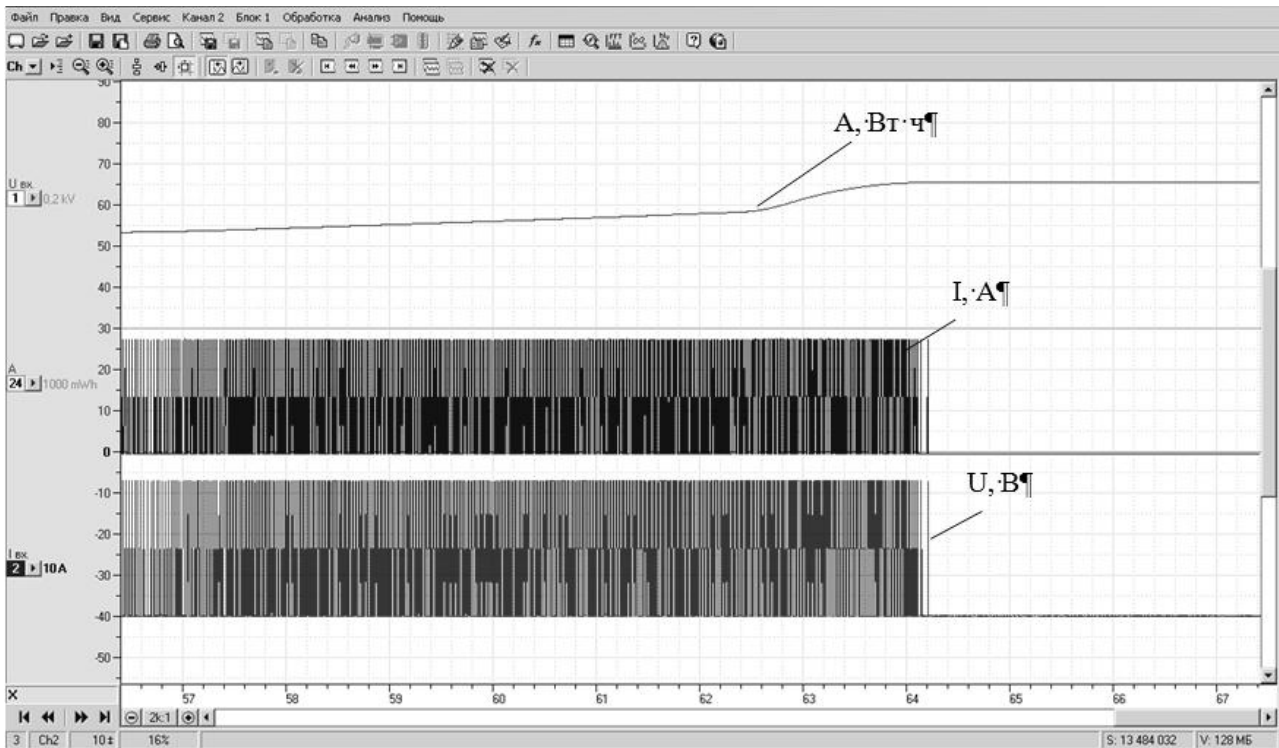

. 6.

-040-6

,
 -
 -
 -
 ,
 5 ,
 - 18 ,
 0,6 , 8,2 , 3,2 .
 .
 -100-6 1000 , OVF20, 12
 , , . 1000 , -
 2,67 . , -
 - 1,2 . . -
 . -
 (-
 , , -
 30 -024,
 OMRON L7 WARISPEED, -)
 -0,6 (35), -
 225 -6/24V 17,5 (-
 , 940/210 -1. -)
 1,6 / . -
 -
 -100-6 , -040-6 OTIS,
 MCS 220-C GEN2 OVF20
 6,4 371
 -1. , -
 S -
 -

14,6 , 22 , -
 -1,8 . . .

, , ()
 , ()
 U ,
 ,
 ()
 Reynolds &
 Reynolds 2002 .
 Traction Powervator ,
 [5]. U .
 2,
 Emotron ,
 -47 « DSV [3].
 »
 (DC/DC) [4].
 [2]. - () ;
 () ;
 - ;
 U , -
 U .

1.

	-040-6	-100-6	OTIS OVF20	OTIS GEN2
	24	24	25	7
,	0,4	1	1	1
	.	.	.	-
	5	2,67	31	22
1	0,6	1,2	18	14,6
2	-	-	8,2	10*
3	-	-	3,2	5*
4	-	-	-	1,8

.*

7, -
 1 – 3, -
 8, -
 2. 1
 U_1 , 2 -
 U_2 , 3 -
 . 7 -
 1, -
 « » -
 (). -
 2, -
 3, -
 2. $U_1 - U_3$. -
 4, $U_3 \sim$
 (DC/DC U . -
 3) 5 -
 - (). -
 6: $U_2 (U_2 - U_1) U_1, U_1 -$ -
 , -
 , -
 (. 3) U_1 .

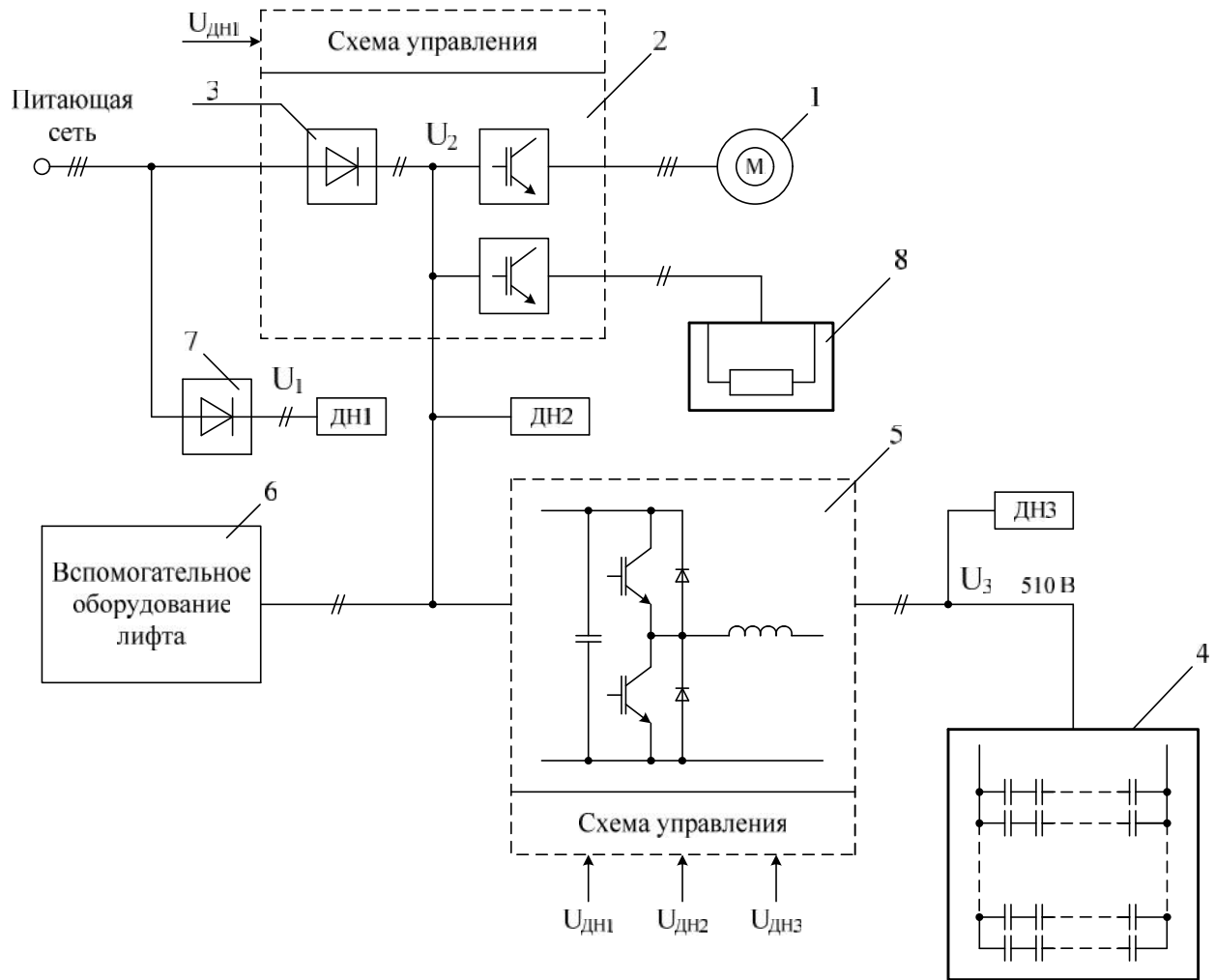

. 7.

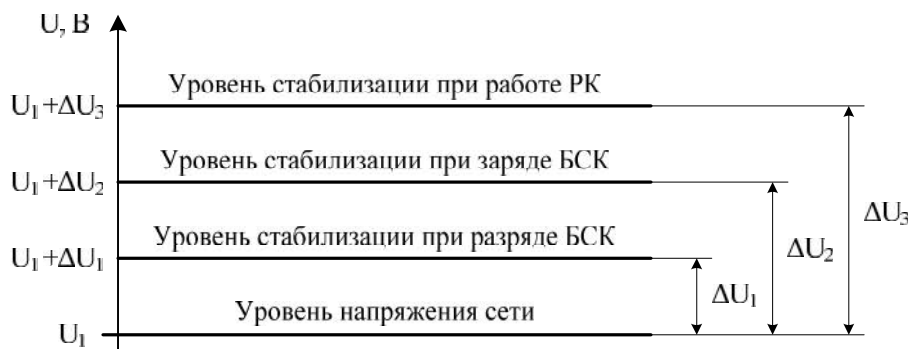

. 8.

$$U_1) \quad U_1 \quad (U_2 - \quad U_2 \quad (U_1 + \quad U_2), \quad U_1 > \quad U_2.$$

$$U_3 \quad U \quad , \quad - \quad - \quad -$$

$$R \quad , \quad - \quad - \quad - \quad U_1, \quad -$$

$$U_2 \quad , \quad - \quad - \quad - \quad t, \quad -$$

$$1.$$

$$U_1 \ll U, \quad U -$$

$$U_1$$

$$U_1,$$

« ».

(

,

1. Bilbao E., Barrade Ph., Etxeberria-Otadui I., Rufer A., Luri S., and Gil I., (2014), Optimal Energy Management Strategy of an Improved Elevator With Energy Storage Capacity Based on Dynamic Programming, *IEEE Transactions on Industry Applications*, Vol. 50, No. 2, pp. 1233 – 1244. DOI: 10.1109/TIA.2002.803021.

2. Jabbour N., Mademlis C., and Kioskeridis I., (2014), Improved Performance in a Supercapacitor-Based Energy Storage Control System with Bidirectional DC-DC Converter for Elevator Motor Drives, *7th IET International Conference on Power Electronics, Machines and Drives (PEMD 2014)*, pp. 1 – 6. DOI: 10.1049/cp.2014.0487.

3. Minav T., Hänninen H., Sinkkonen A., Laurila L., and Pyrhönen J., (2014), Electric or Hydraulic Energy Recovery Systems in a Reach Truck – A Comparison, *Strojniški Vestnik - Journal of Mechanical Engineering*, Littera Picta, Ljubljana, Slovenia, Vol. 60, No. 4, pp. 232 – 240. DOI: 10.5545/sv-jme.2013.1581.

4. Rufer A., and Barrade P.A., (2002), Supercapacitor-Based Energy-Storage System for Elevators with Soft Commutated Interface, *IEEE Transactions on Industry Applications*, Vol. 38, No. 5, pp. 1151 – 1159. DOI: 10.1109/TIA.2002.803021.

5. Schroeder J.C., and Fuchs F.W., (2015), General Analysis and Design Guideline for a Battery Buffer System With DC/DC Converter and EDLC for Electric Vehicles and its Influence on Efficiency, *IEEE Transactions on Power Electronics*, Vol. 30, No. 2, pp. 922 – 932. DOI:10.1109/TPEL.2014.2313811.

6.

7. « » – 2010. – 2. – 23 – 28.

7.

8. « » – 2011 – 5. – 17 – 20.

8.

9. « » // « » – 2011 – 5. – 24 – 25.

9.

10. « » // « » – 2011. – 2 (78). – 7 – 12.

10.

11. « » – 2011. – 1. – 45 – 47.

11.

12. « » // « » – 2011. – 14.3. – 367 – 376.

22.10.2014

References

1. Bilbao E., Barrade Ph., Etxeberria-Otadui I., Rufer A., Luri S., and Gil I., (2014), Optimal Energy Management Strategy of an Improved Elevator With Energy Storage Capacity Based on Dynamic Programming, *IEEE Transactions on Industry Applications*, Vol. 50, No. 2, pp. 1233 – 1244. DOI: 10.1109/TIA.2002.803021.

2. Jabbour N., Mademlis C., and Kioskeridis I., (2014), Improved Performance in a Supercapacitor-Based Energy Storage Control System with Bidirectional DC-DC Converter for Elevator Motor Drives, *7th IET International Conference on Power Electronics, Machines and Drives (PEMD 2014)*, pp. 1 – 6. DOI: 10.1049/cp.2014.0487.

3. Minav T., Hänninen H., Sinkkonen A., Laurila L., and Pyrhönen J., (2014), Electric or Hydraulic Energy Recovery Systems in a Reach Truck – A Comparison, *Strojniški Vestnik – Journal of Mechanical Engineering, Littera Picta, Ljubljana, Slovenia*, Vol. 60, No. 4, pp. 232 – 240. DOI: 10.5545/sv-jme.2013.1581.

4. Rufer A., and Barrade P. A., (2002), Supercapacitor-Based Energy-Storage System for Elevators with Soft Commutated Interface, *IEEE Transactions on Industry Applications*, Vol. 38, No. 5, pp. 1151 – 1159. DOI: 10.1109/TIA.2002.803021.

5. Schroeder J.C., and Fuchs F.W., (2015), General Analysis and Design Guideline for a Battery Buffer System With DC/DC Converter and EDLC for Electric Vehicles and its Influence on Efficiency, *IEEE Transactions on Power Electronics*, Vol. 30, No. 2, pp. 922 – 932. DOI: 10.1109/TPEL.2014.2313811.

6. Andryushchenko O.A., Bulgar V.V., and Semenyuk V.F. Passazhirska lift kak elektromekhanicheskaya sistema. Perspektivy i problemy sovershenstvovaniya energeticheskikh pokazatelei [Passenger Elevator as Electromechanical System. Perspectives and Problems of Improving Energy Performance], (2010), *Lifting equipment. Spec. Machinery*, No. 2, pp. 23 – 28 [In Russian].

7. Ishkhanov E.P. ShULM – naibolee otrabotanniy i perspektivnyy liftovoy shkaf upravleniya [CCEM – Spent most Promising and Elevator Control Cabinet], (2011), *Lift, OMOR “National League of Elevator Companies and Municipal Infrastructure”*, No. 5, pp.17 – 20 [In Russian].

8. Preobrazovateli chastoty Emotron (Shvetsiya) dlya lyubykh tipov liftovykh lebedok, [Press

Service, “Lift Kit”, Frequency Converters Emotron (Sweden) for all Types of Lift Winches], (2011), *Lift, OMOR “National League of Elevator Companies and Municipal Infrastructure”*, No. 5, pp. 24 – 25 [In Russian].

9. Smotrov E.A. Rekuperator bortovogo istochnika pitaniya elektrotransportnogo sredstva [Re recuperator of the Onboard Power Supply Vehicles], (2011), *Electrical and Computer Systems*, Kiev, Ukraine, *Science*, No. 2 (78), pp.7 – 12 [In Russian].

10. Wilk S. Budushchee – eto seichas [Future – it Now], (2011), *Lift, OMOR “National League of Elevator Companies and Municipal Infrastructure”*, No. 1, pp. 45 – 47 [In Russian].

11. Khitrov A.I., and Khitrov A.A. Perspektivy primeneniya energosberegayushchikh reshenii v elektro-privodakh glavnogo dvizheniya lifta [Prospects of Application of Energy-Efficient Electric Drives in the main Elevator Movement], (2011), *Proceedings of Pskov Polytechnical Institute*, Pskov, Russian Federation, *Pub: PPI*, No. 14.3, pp. 367 – 376 [In Russian].



«
»,
. (048)728-85-05,
. , 16,
, , 65011.

E-mail:
ukr niisip@gmail.com



II
-
«
»,
. (048)728-85-05,
. , 16,
, , 65011.

E-mail: ukr niisip@gmail.com