

УДК 66.074.1

**A.D. Gutak**Poltava National Technical Yuri Kondratyuk University,  
24 Pershotravnevyi av., Poltava, 36011, Ukraine**NUMERICAL SIMULATION OF TEMPERATURE SEPARATION IN METHANE STREAM IN RANQUE-HILSCH VORTEX TUBE**

*In present numerical research, the temperature separation in methane stream within a counter flow Ranque-Hilsch vortex tube was investigated. A complete three-dimensional geometry of the vortex tube was used to generate a high-density computational grid. A vortex tube with two tangential inlet nozzles, an axial cold stream outlet and a circumferential hot stream outlet was considered. Methane was used as a fluid along with Peng-Robinson cubic equation of state. Fluid properties like total temperature and total pressure were analyzed for a range of inlet mass flow rates and inlet total pressure values. Also the total pressure and total temperature distribution along the axial direction was investigated. The temperature separation effect is more significant for air then for methane at all investigated pressures. Created model can be used to design industrial vortex tubes for oil and gas industry where methane is a main product.*

**Keywords:** Ranque-Hilsch vortex tube; Energy separation; Large eddy simulation; Real gas equation of state; Methane

**A. Д. Гутак**Полтавський національний технічний університет ім. Ю.Кондратюка,  
Першотравневий проспект, 24, м. Полтава, 36011, Україна**ЧИСЕЛЬНЕ МОДЕЛЮВАННЯ РОЗПОДІЛУ ТЕМПЕРАТУРИ В ПОТОЦІ МЕТАНУ У ВИХРОВІЙ ТРУБІ РАНКА-ХІЛША**

*У роботі розглянуто розподіл температури в потоці метану всередині протиточної вихрової труби Ранка-Хілша. Тривимірну геометричну модель вихрової труби було використано для створення обчислювальної сітки з високою щільністю. Розглянуто вихрову трубу з двома тангенціальними вхідними соплами, осьовим виходом холодного потоку і периферійним виходом гарячого потоку. Метан був використаний в якості флюїду разом з кубічним рівнянням стану Пенга-Робінсона. Були проаналізовані такі властивості середовища як повна температура і повний тиск для діапазону вхідних масових витрат і значень повного тиску на вході. Крім того, було досліджено розподіл повного тиску і повної температури уздовж осьового напрямку. Ефект розподілу температури виявився більши значущим для повітря, ніж для метану при всіх досліджених тисках. Створена модель може бути використана для розробки промислових вихрових труб для нафтової і газової промисловості, де метан є основним продуктом.*

**Ключові слова:** вихрова труба Ранка-Хілша; розподіл енергії; моделювання великих вихорів; рівняння стану реального газу; метан

DOI: 10.15673/0453-8307.3/2015.35982



This work is licensed under the Creative Commons Attribution International License (CC BY).  
<http://creativecommons.org/licenses/by/4.0/>

**I. INTRODUCTION**

Vortex tube is a device that has no moving parts and acts like a heating and cooling machine at the same time. This happens due to Ranque effect that was first discovered by J. Ranque (1931). Later, R.Hilsch (1947) performed complex investigations on this effect. In vortex tube high-pressure inlet stream is divided into two separate lower pressure streams. One has higher temperature and other lower. Vortex tube has a wide range of applications such as instruments

cooling, gas species separation, dehydration of natural gas, firefighter's equipment cooling etc.

Despite long period of investigations, there is still no adequate physical model of Ranque effect. In experimental study, it is not possible to measure stream parameters inside tube. Using any instruments inside it causes additional turbulence and flow structure rearrangement. Temperature separation in vortex tube is a result of complex hydrodynamic processes and can be studied in details with the help of computational fluid dynamics methods. Linderstrom-

Lang (1971) performed first numerical investigations. Two-dimensional algebraic viscosity model with ideal gas law was used. Cockerill (1995) investigated temperature separation with 2D k-ε model and ideal gas law. Aljuwayhel et al. (2005) performed parametric and internal study of the vortex tube using k-ε and RNG- k-ε models. Behera et al. (2008) investigated flow behaviour and energy separation in Ranque-Hilsch vortex tube with pseudo 3D RNG- k-ε model and ideal gas law. Eiamsa-ard et al. (2008)

simulated flow field and temperature separation in a vortex tube using k-ε and ASM 2D models. Farouk et al. (2009) simulated gas species and temperature separation in the counter-flow Ranque–Hilsch vortex tube using 2D LES model. Secchiaroli et al. (2009) performed numerical simulation of turbulent flow in a Ranque-Hilsch vortex tube using 2D RNG- k-ε, RSM and LES models. Most of all numerical investigations were performed with 2D geometrical mesh and ideal gas law.

Nomenclature			
$a$	Peng-Robinson EOS coefficient	$T$	Temperature (K)
$b$	Peng-Robinson EOS coefficient	$T_c$	Critical temperature (K)
$C_w$	LES-WALE calibration constant	$t$	Time (s)
$D$	Vortex tube internal diameter (mm)	$u$	Velocity vector (m/s)
$d$	Orifice diameter (mm)	$V$	Specific volume (m <sup>3</sup> /mol)
$dn$	Nozzle internal diameter (mm)	<i>Greek symbols</i>	
$Dc$	Cold exit internal diameter (mm)	$\alpha(T)$	Temperature function
$G_i$	Inlet mass flow rate (kg/s)	$\delta$	Kronecker symbol
$G_h$	Hot stream mass flow rate (kg/s)	$\lambda$	Thermal conductivity (W/m K)
$G_c$	Cold stream mass flow rate (kg/s)	$\mu_{SGS}$	Eddy viscosity (kg/m s)
$h$	Specific static enthalpy (J/kg)	$\rho$	Density (kg/m <sup>3</sup> )
$h_0$	Specific total enthalpy (J/kg)	$\tau$	Shear stress (N/m <sup>2</sup> )
$L$	Vortex tube length (mm)	$\omega$	Acentric factor
$m$	Peng-Robinson EOS parameter	<i>Subscripts</i>	
$n$	Number of nozzles	$c$	Cold
$p$	Pressure (Pa)	$h$	Hot
$p_c$	Critical pressure (Pa)	$i$	Inlet
$R$	Universal gas constant (J/mol K)		
$S$	local strain rate		

Current research is devoted to Ranque-Hilsch vortex tube, which investigation is of practical interest for Oil and Gas industry due to its promising application as an alternative to Joule-Thomson valve. For the first time CFD modeling of methane stream in vortex tube was performed. In addition, we have used Peng-Robinson equation of state to model real gas behavior of methane.

Several experiments were performed on natural gas processing plant and compared here with CFD data. As far as methane was not used previously, we also compared CFD results with those for air.

## II. MATHEMATICAL MODEL

In this investigation, a three-dimensional compressible turbulent real gas flow was under consideration. The governing equations used to describe mass, momentum and energy conservation are as follows (Versteeg, Malalasekera, 1995).

Mass conservation equation:

$$\frac{\partial \rho}{\partial t} + \nabla \cdot (\rho u) = 0 \quad (1)$$

Momentum conservation equation:

$$\frac{\partial(\rho u)}{\partial t} + \nabla \cdot (\rho u u) = -\nabla p + \nabla \tau \quad (2)$$

Energy conservation equation:

$$\frac{\partial(\rho h_0)}{\partial t} + \nabla(\rho u h_0) = \frac{\partial p}{\partial t} + \nabla(\lambda \nabla T) - \nabla(\tau \cdot u) \quad (3)$$

Specific total enthalpy is defined as follows:

$$h_0 = h + \frac{1}{2}(u^2 + v^2 + w^2) \quad (4)$$

where  $u, v, w$  – velocity components in Cartesian coordinates.

In this CFD model, we used Peng-Robinson equation of state that is usually used to describe hydrocarbon gases behavior (Whitson, Brulé, 2000). It has the following form:

$$p = \frac{RT}{V-b} - \frac{a \alpha(T)}{V^2 + 2bV - b^2} \quad (5)$$

Coefficients  $a$  and  $b$  in equation (5) are defined as follows:

$$a = 0,45724 \frac{R^2 T_c^2}{p_c} \quad (6)$$

$$b = 0,0778 \frac{RT_c}{p_c} \quad (7)$$

Peng and Robinson proposed following expression for temperature function  $\alpha(T)$

$$\alpha(T) = \left[ 1 + m \left( 1 - \sqrt{\frac{T}{T_c}} \right) \right]^2 \quad (8)$$

where parameter  $m$  depends on acentric factor  $\omega$  in the following way:

$$m = 0.379642 + 1.48503\omega - 0.1644\omega^2 + 0.016667\omega^3 \quad (9)$$

### III. TURBULENCE MODEL

For turbulence modeling, LES model is used in this investigation. The main idea in the LES technique is to separate large and small scales. The governing equations for LES model are obtained by filtering the time-dependent Navier-Stokes equations in the physical space. The filtering process filters out the eddies whose scales are smaller than the filter width or grid spacing used in the computations. The resulting equations thus govern the dynamics of the large eddies (SAS IP Inc., 2013). The large-scale turbulent flow is solved directly and the small scales are computed from subgrid-scale (SGS) turbulent model.

In the LES technique, subgrid-scale Reynolds stress tensor is related to eddy-viscosity as follows (SAS IP Inc. 2013):

$$-\left(\tau^* - \frac{\delta}{3}\tau\right) = 2\mu_{SGS}\bar{S} \quad (10)$$

where  $\bar{S}$  is the local strain rate.

$$\bar{S} = \frac{1}{2}(\nabla\mathbf{u} + (\nabla\mathbf{u})^T) \quad (11)$$

According to the wall-adapted local eddy-viscosity model (WALE) (Nicoud, Ducros 1999) the following equation is used to compute the eddy-viscosity:

$$\mu_{SGS} = (C_w\Delta)^2 \frac{(S^d S^d)^{3/2}}{(S S)^{5/2} + (S^d S^d)^{5/4}} \quad (12)$$

where  $C_w = 0.5$ .

### IV. GEOMETRICAL MODEL

The CFD model in present research is based on the developed small-scale vortex tube that we used in field experiments. A schematic view and basic dimensions of this geometry is represented in Fig. 1 and summarized in Table 1.

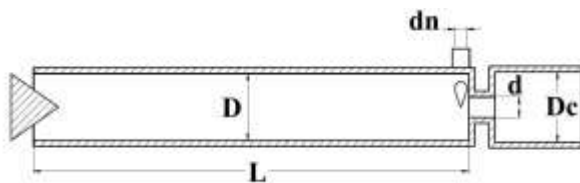

Fig. 1. Schematic view of the vortex tube geometry

In current research we used a vortex tube with two tangential nozzles. To reduce instability on cold exit

cylindrical element with internal diameter  $D_c$  was added to the end of orifice. This allows us to provide correct boundary conditions on cold exit. In front of nozzles, large cylindrical elements were attached. Such inlet is necessary for correct simulation of inflow stream behavior.

Table 1. Geometric parameters for the vortex tube model

Tube ID	D	mm	7.5
Tube length	L	mm	100
Nozzles ID	dn	mm	1.5
Nozzles number	n	–	2
Orifice diameter	d	mm	3.5
Cold exit ID	Dc	mm	8

To make use of this geometry we created a solid model that represents a computational domain. It is a copy of our experimental vortex tube internal volume (Fig. 2).

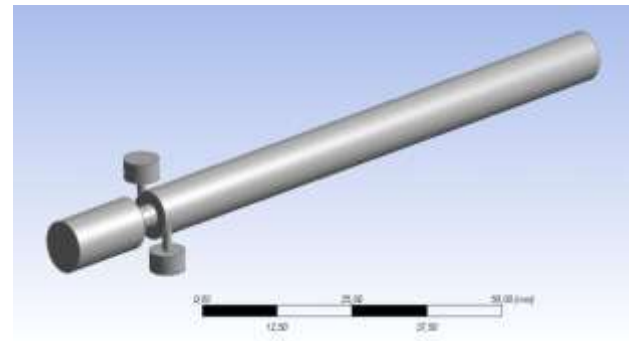
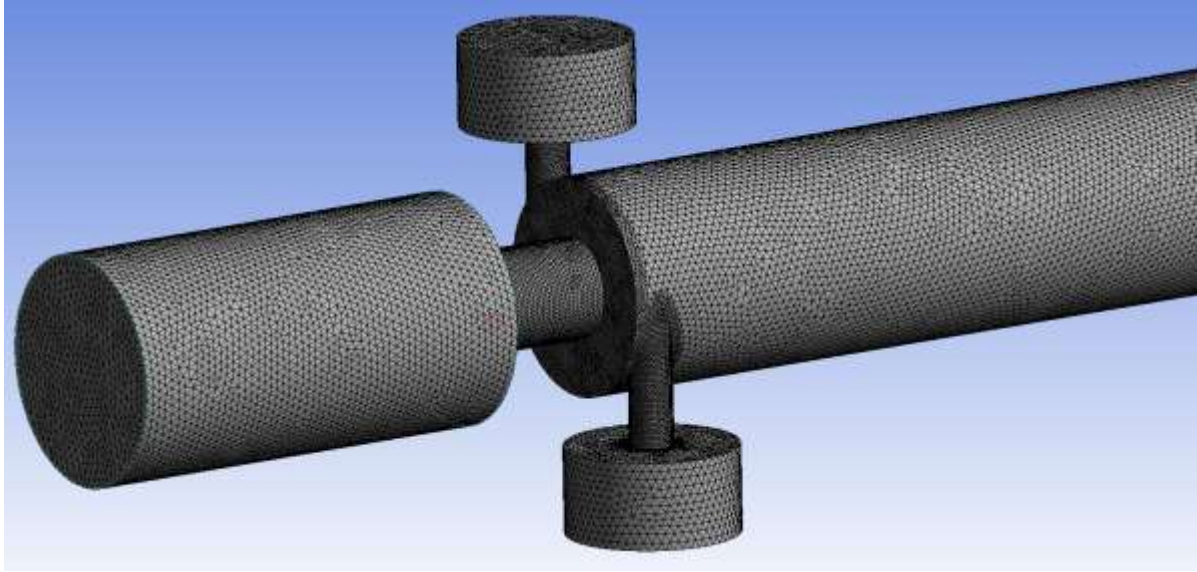

Fig. 2. Computational domain

Some simplifications were applied to it. For example, hot exit ends with conical valve and not with a tee. The form of inlet chamber was also simplified for convenience. Simplifications were made in that regions where it does not have big influence and allow us to decrease computational mesh size.

### V. COMPUTATIONAL MODEL

In current study, we used a complete three-dimensional grid. Tetrahedral mesh with maximum element face size of 0.3 mm was generated. Minimum element size was set to 0.005 mm. The number of elements reached 1038416 and the number of nodes was 199486. A part of this mesh is shown in Fig. 3. A local mesh refinement of first order was applied to hot exit area, orifice and nozzles inlet. The high mesh resolution allowed us to get more details on vortex structures inside a tube.



**Fig. 3.** Computational mesh

For this model, we applied boundary conditions in locations shown in Fig. 4.

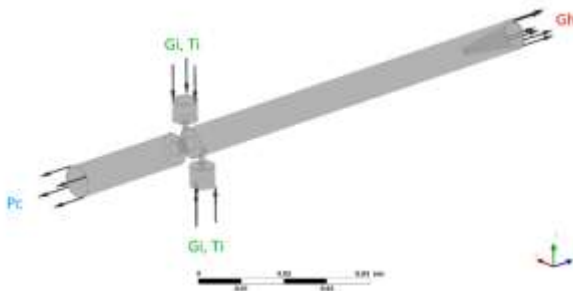

**Fig. 4.** Boundary conditions

Inlet stream mass flow rate for each nozzle was set to  $G_i = 0.001 \text{ kg/s}$ , inlet gas total temperature was equal  $T_i = 303 \text{ K}$ . Atmospheric pressure was specified at the cold exit of the vortex tube, t.e.  $P_c = 0 \text{ atm}$ .

Hot stream mass flow rate  $G_h$  was a simulation variable and has been changing for different series of computations. Cold mass fraction then was calculated as

$$\mu = \frac{2G_i - G_h}{2G_i} \quad (13)$$

Methane was set as domain fluid. To compute its properties Peng-Robinson equation of state was used. All tube walls were considered adiabatic, without any heat transfer to environmental air. No slip wall condition was used with wall roughness 0.03 mm.

Since we have used LES turbulence model, initial conditions and time parameters should be set for our domain. Initial pressure  $P_0$  in the tube was equal to atmospheric pressure. Initial velocity components were set to 1 m/s. Initial temperature was set at level of 303 K.

Time step size of  $10^{-4} \text{ s}$  was chosen for the Second Order Backward Euler scheme. The calculations

within a given time step are continued for a convergence criteria of  $10^{-4}$  for the solving variables. During computation process mass, momentum and energy balances were controlled as well as their residuals. Other important parameters that were controlled are energy, momentum and mass accumulation in computational domain. The iterations were terminated when a pseudo steady-state behavior was observed, which corresponds to steady fluctuations in velocity, temperature, pressure and density. It should be noted that mass, momentum and energy accumulation and their balances must also approach zero.

## VI. RESULTS AND DISCUSSION

The LES simulations were performed on the workstation equipped with 6-core Intel Core i7 990X 3.4 GHz processor, 3 TB HDD, 24 GB DDR3 memory. Computational time in LES simulation was about 5 – 6 h for each value of cold stream mass fraction.

The model was tested for three levels of inlet mass flow rate  $G_i$  that correspond to three levels of inlet pressure  $P_i$ . On each level, five different simulations were performed by varying the hot exit mass flow rate  $G_h$ . The hot stream mass flow rate was taken from range 10, 30, 50, 70 and 90% of the inlet mass flow rate equal  $2G_i$ . Current analysis is focused on the investigation of total temperature and total pressure distribution in the flow field.

Fig. 5 shows contours of the total pressure for different values of cold stream mass fraction  $\mu$ .

Fig. 6 shows contours of the total temperature for different values of cold stream mass fraction  $\mu$ . Total inlet pressure in this case was about 2 atm.

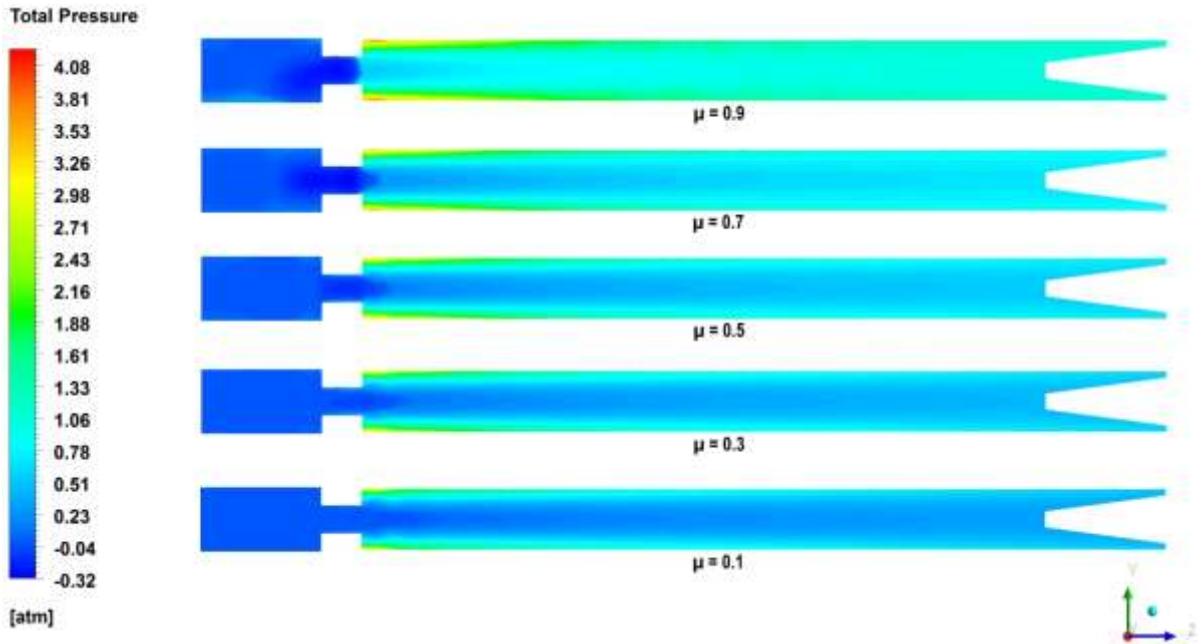

Fig. 5. Contours of total pressure in YZ plane

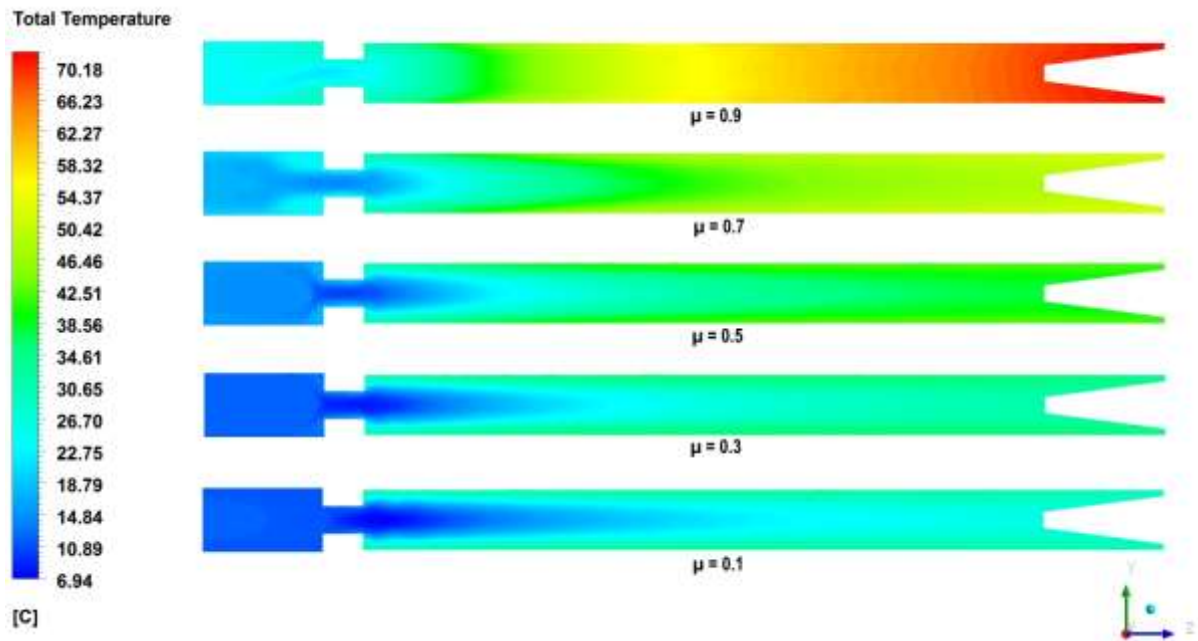

Fig. 6. Contours of total temperature in YZ plane

In Fig. 5 it can be seen that in core region of vortex tube model a low pressure stream is forming. Increase in cold stream mass fraction  $\mu$  causes pressure decrease in this area. However, when the value of  $\mu$  is too big, critical flow through the orifice of vortex tube can be achieved. This can be clearly seen in Fig. 5 when  $\mu = 0.9$ . The lowest total pressure level in core region is observed when cold stream mass fraction approaches zero. Absolute pressure in this area can fall below atmospheric that causes ejecting of environmental air into the vortex tube.

In Fig. 6 one can see that heating effect increases when cold stream mass fraction approaches  $\mu = 1.0$ . Maximum value of hot stream total temperature received at  $P_i = 2$  atm is about  $72$  °C. Cooling effect

has opposite behavior. It increases with cold stream mass fraction decrease. Total temperature has a minimum value at cold stream mass fraction  $\mu \approx 0$ . It is not a typical behavior of vortex tube. As reported in (Aydın, Baki, 2006; S. Eiamsa-ard, 2010; Promvonge, Eiamsa-ard, 2005) the lowest cold stream total temperature is found at  $\mu \approx 0.3$  while the highest hot stream total temperature is at  $\mu \approx 0.7$ . To get the answers we have compared simulation results with data achieved from experimental investigations performed on natural gas processing plant. Fig. 7 shows the comparison of simulation results and experimental data. As was mentioned above the lowest cold stream total temperature in field data is found at  $\mu \approx 0.35$  and the highest hot stream total

temperature is at  $\mu \approx 0.7$ . Thus, our model is accurate in range  $\mu = 0.3 - 1$  for cold stream total temperature and in range  $\mu = 0 - 0.7$  for hot stream total temperature. We can see relatively good accuracy of simulation data for hot and cold streams total temperature. Interesting behavior of our CFD model can be explained by adiabaticity of the process. In real world when measuring temperature at small flow rates of one of the streams an intensive heat transfer occurs through the tube wall between internal fluid and environmental air. As flow rate and velocity of cold or hot stream is too small after the exit the heat transfer is directed into the tube. Therefore, the measurements in the cold or hot exit pipes could show results that are

far from ideal CFD model. It should be mentioned that field experiments show vortex tube heating even at very low hot stream mass fractions. In some way, this corresponds to our CFD model and should be further investigated.

Fig. 8 shows the influence of inlet pressure level on temperature differences for cold and hot streams. As was expected the hot stream total temperature has higher values with total pressure increase. Cold stream total temperature become lower with higher pressures. Obviously, energy separation become more intensive with higher inlet pressures because of tangential velocity increase that causes larger pressure gradients.

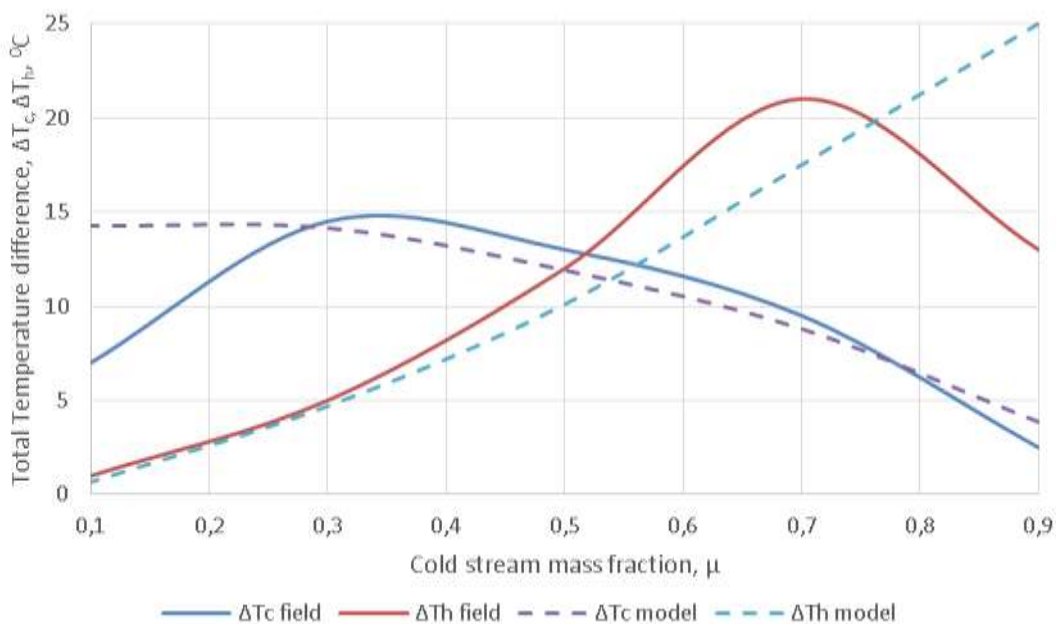

Fig. 7. Comparison of simulation results and experimental data at  $P_i = 2 \text{ atm}$ ,  $T_i = 30 \text{ }^\circ\text{C}$

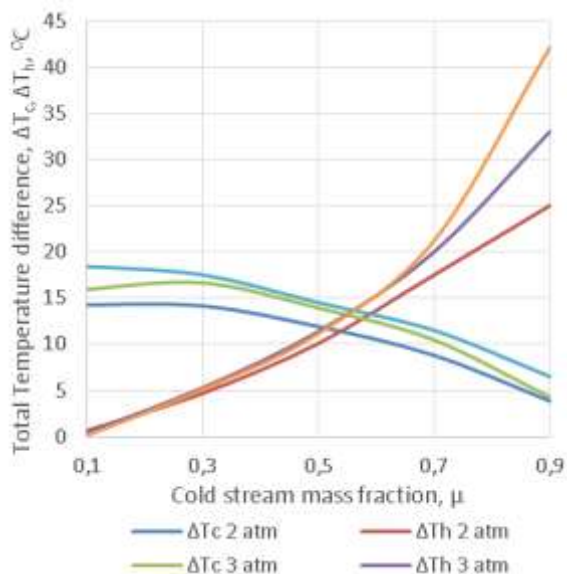

Fig. 8. The total temperature differences at different levels of inlet pressure

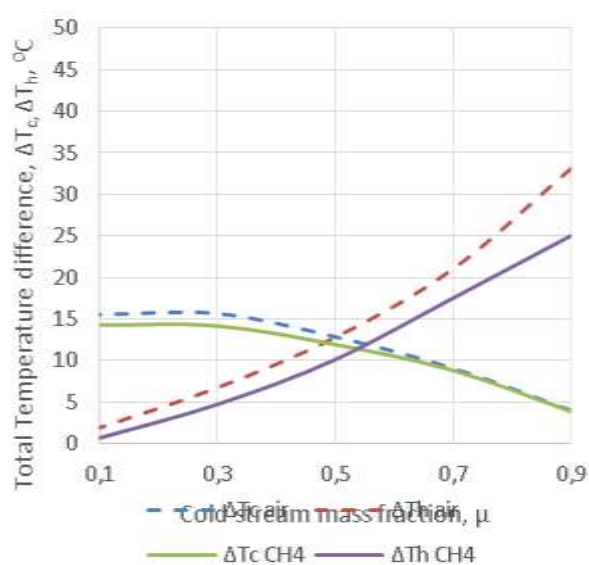
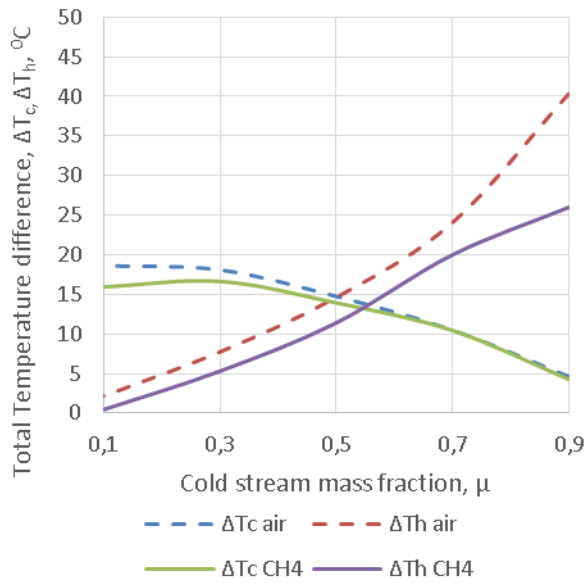
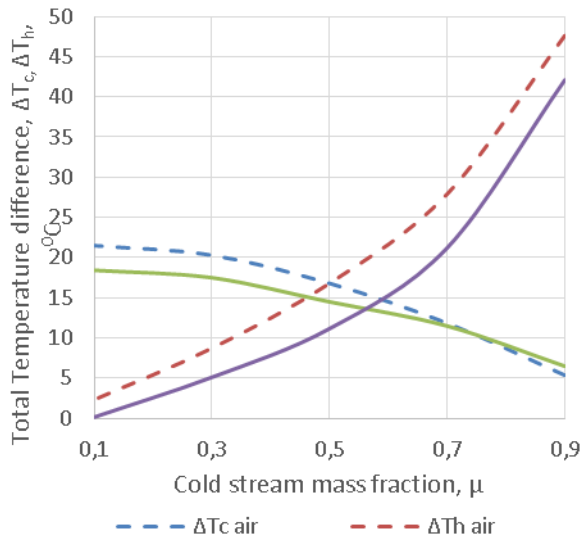

Fig. 9. The total temperature differences for air and methane,  $P_i \approx 2 \text{ atm}$

The main objective of current investigation is to compare the temperature separation effect for air and methane. To reach this we performed the same simulations for air as was done for methane. The comparison between these two gases was carried out for three levels of inlet total pressure: 2, 3, 4 atm. The results are shown in Fig. 9 – 11. As we can see the temperature separation effect is more significant for air than for methane at all investigated pressures.



**Fig. 10.** The total temperature differences for air and methane,  $P_i \approx 3$  atm



**Fig. 11.** The total temperature differences for air and methane,  $P_i \approx 4$  atm

## CONCLUSIONS

A three-dimensional numerical model of Ranque-Hilsch vortex tube has been developed to analyze the flow parameters and energy separation effect in

methane stream. For turbulence modeling, LES model was used in this investigation. The comparison between temperature separation effects for air and methane streams has been conducted.

The following conclusions were made.

- The temperature separation effect is more significant for air than for methane at all investigated pressures.
- Low pressure zone forms in the core region of the vortex tube. Absolute pressure in this area can be lower than atmospheric pressure. This can cause the ejecting effect.
- High values of cold stream mass fraction causes critical flow through the orifice. As a result total pressure inside vortex tube increases.
- Current numerical model of the vortex tube shows a good accuracy in cold and hot stream temperature prediction but some anomalies exist for hot stream temperature.
- Temperature separation effect becomes more significant with inlet pressure increase.

Created model can be used to predict temperature separation effect in methane stream. As far as there is no adequate physical model of Ranque effect, results of current investigations could help to design industrial vortex tubes for oil and gas industry where methane is a main product.

## REFERENCES

- Aljuwayhel, N.F., Nellis, G.F., Klein, S.A., Parametric and internal study of the vortex tube using a CFD model, *International Journal of Refrigeration* 28 (2005) 442–450.
- ANSYS CFX-Solver Theory Guide, SAS IP Inc., Canonsburg, 2013, pp. 109 – 114.
- Aydın, O., Baki, M., An experimental study on the design parameters of a counterflow vortex tube, *Energy* 31 (2006) 2763–2772.
- Behera, U., Paul, P.J., Dinesh, K., Jacob, S., Numerical investigations on flow behaviour and energy separation in Ranque–Hilsch vortex tube, *International Journal of Heat and Mass Transfer* 51 (2008) 6077–6089.
- Cockerill, T., Ranque-Hilsch vortex tube, the M.S. Thesis, Engineering Department at Cambridge University, 1995.
- Eiamsa-ard, S., Promvong, P., Numerical simulation of flow field and temperature separation in a vortex tube, *International Communications in Heat and Mass Transfer* 35 (2008) 937–947.
- Eiamsa-ard, S., Experimental investigation of energy separation in a counter-flow Ranque-Hilsch vortex tube with multiple inlet snail entries, *International Communications in Heat and Mass Transfer* 37 (2010) 637–643.
- Farouk, T., Farouk, B., Gutsol, A., Simulation of gas species and temperature separation in the counter-flow Ranque–Hilsch vortex tube using the large eddy simulation technique, *International Journal of Heat and Mass Transfer* 52 (2009) 3320–3333.

- Hilsch, R., The use of the expansion of gases in a centrifugal field as cooling process, Rev. Sci. Instrum. 18 (2) (1947) 108–113.
- Linderstrom-Lang, C., Studies on transport of mass and energy in the vortex tube – The significance of the secondary flow and its interaction with the tangential velocity distribution. Riso report, Denmark, September.
- Nicoud, F., Ducros, F., Subgrid-scale stress modelling based on the square of the velocity gradient tensor, Flow, Turbulence and Combustion, 62, pp. 183–200, 1999.
- Promvongse, P., Eiamsa-ard, S., Investigation on the vortex thermal separation in a vortex tube refrigerator, ScienceAsia 31 (2005) 215–223.
- Ranque, G.J., Expériences sur la détente giratoire avec productions simultanés d'un échappement d'air chaud et d'un échappement d'air froid, J. Phys. Radium 4 (7) (1933) 112–114.
- Secchiaroli, A., Ricci, R., Montelpare, S., D'Alessandro, V., Numerical simulation of turbulent flow in a Ranque-Hilsch vortex tube, International Journal of Heat and Mass Transfer 52 (2009) 5496–5511.
- Versteeg, H.K., Malalasekera, W., An introduction to computational fluid dynamics. The finite volume method, Longman Group Ltd., Essex, 1995, pp. 10–24.
- Whitson, C.H., Brulé, M.R., Phase Behavior, Henry L. Doherty Memorial Fund of AIME, Society of Petroleum Engineers Inc., Richardson, Texas, 2000, pp. 47 – 52.

**А. Д. Гутак**

Полтавский национальный технический университет им. Ю.Кондратюка,  
Первомайский проспект, 24, г. Полтава, 36011, Украина

## **ЧИСЛЕННОЕ МОДЕЛИРОВАНИЕ РАСПРЕДЕЛЕНИЯ ТЕМПЕРАТУРЫ В ПОТОКЕ МЕТАНА В ВИХРЕВОЙ ТРУБЕ РАНКА-ХИЛША**

*В настоящем численном исследовании рассмотрено распределение температуры в потоке метана внутри противоточной вихревой трубы Ранка-Хилша. Трехмерная геометрическая модель вихревой трубы была использована для создания вычислительной сетки с высокой плотностью. Рассмотрена вихревая труба с двумя тангенциальными входными соплами, осевым выходом холодного потока и периферийным выходом горячего потока. Метан был использован в качестве флюида вместе с кубическим уравнением состояния Пенга-Робинсона. Были проанализированы такие свойства среды, как полная температура и полное давление для диапазона входных массовых расходов и значений полного давления на входе. Кроме того, было исследовано распределение полного давления и полной температуры вдоль осевого направления. Эффект разделения температуры оказался более значимым для воздуха, чем для метана при всех исследованных давлениях. Созданная модель может быть использована для разработки промышленных вихревых труб для нефтяной и газовой промышленности, где метан является основным продуктом.*

**Ключевые слова:** вихревая труба Ранка-Хилша; распределение энергии; моделирование больших вихрей; уравнение состояния реального газа; метан

---

Отримана в редакції 12.01.2015, прийнята до друку 23.04.2015