



Anatychuk L.I.

**SMALL-SIZE THERMOELECTRIC
CURRENT SOURCE OF
SINGLE ACTION**

*Anatychuk L.I., Mikityuk P.D.
(Institute of Thermoelectricity, 1, Nauky Str.,
Chernivtsi, 58029, Ukraine)*



Mikityuk P.D.

-
- *The results of the investigation for the creation of a small-size thermoelectric current source of single action for self-contained control systems of various electronic devices are presented.*

Introduction

Due to a wide application of self-contained control systems on special application objects, the problem of development of electric current sources used for power supply to various electronic devices is currently central.

The use of chemical current sources for the solution of the above mentioned problem is considerably limited by their self-discharge, hence, a short storage period. When the electrolyte components are kept separately to increase the storage period, the applicability of chemical current sources is restricted by a relatively long time required to reach the mode and low reliability under increased climatic and mechanical loads. High fluctuation level of the electric parameters should be also referred to the disadvantages of chemical current sources.

Considerable advantages over chemical current sources are offered by current sources operated by the principle of direct thermal into electric energy conversion, i.e. thermoelectric current sources (TECS). Such TECS [1 – 3] are capable of a long-term operation under normal mechanical and climatic conditions. As heat sources, they employ devices based on liquid or gaseous fuel [4], as well as radiation isotopes [2, 5]. The specific character of heat sources employed in such TECS, alongside with large dimensions, restricts considerably their application area.

Of certain interest is TECS using ram-air warming as a heat source [6]. However, the operating capacity of such TECS is directly related to ambient temperature, not distinguished for stability and fast response.

One can dispose of the above-mentioned disadvantages using in the construction of TECS thermal devices based on pyrotechnic compositions as heat sources. Such heat sources generate thermal energy irrespective of ambient temperature. However, in the known [7] constructions of TECS with a pyrotechnic heat source the latter is arranged outside of thermoelectric converter, which requires thorough thermal insulation from the application object. Moreover, such devices do not possess fast response, which is due to low combustion rate of used pyrotechnic composition and the imperfection of heat source design.

The purpose of this work is investigation for the creation of a small-size TECS of single action with a pyrotechnic heat source possessing a long storage period and fast response, improved reliability under considerable mechanical and climatic effects.

Thermoelectric converter (TEC) for TECS

In the design of a TEC, a series of initial requirements was taken into account, namely high thermoelectric figure of merit of thermoelectric material (TEM), ease of TEC manufacture, high

reliability, resistance against excessive climatic and mechanical effects.

The results of theoretical and experimental investigations have proved the advisability of using in TEC construction specially elaborated thermoelectric module of increased reliability. Such a module is a stand-alone unit, i.e. a combination of thermoelements (thermocouples) formed and interconnected into a series circuit by junction-free method in the process of extrusion of inhomogeneous n -, p -type thermoelectric material based on Bi_2Te_3 . The total Seebeck coefficient of TEM is about $300 \mu\text{V/K}$. For compactness and fabricability reasons, the module was made in the form of a spiral. For a considerable increase of TEC reliability the half-elements in the module were shunted by conductors the resistance of which exceeded the resistance of half-elements by an order of magnitude. In the TEC, n , p -junctions were shunted by conductors with a low ohmic resistance which allows, apart from reliability increase, to improve the energy profile of module due to reduced voltage drop on the resistances of n , p -junctions.

The structure of a spiral-type module is shown in Fig. 1. The module consists of a spiral-shaped billet 1 of extruded n -, p -type TEM filled with thermal resistant compound 2. A high-resistant shunt 3 is wound over the external surface of billet 1. Along the billet surfaces corresponding to n , p -junctions the shunt is placed into chutes provided in TEM body. The shunt ends are soldered to leads 5 on the side of cold n , p -junctions. Leads 5 are also used to assure connection of modules in TECS. On the surface of coils of billet 1 corresponding to n , p -junctions, as well as on the surface of chutes and shunts placed in them by galvanic method, there is a thin nickel layer deposited to form a low-resistance shunt 4 of n , p -junction. In the process, due to galvanic contact, the high-resistance shunts prove to be switched parallel to n , p -half-elements of the module.

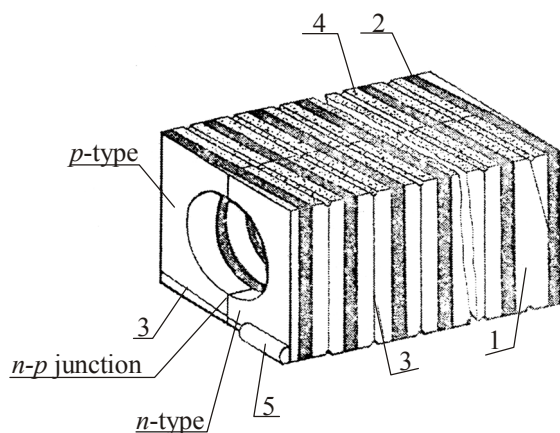

Fig. 1. Thermoelectric module of spiral type.

To obtain modules of spiral type, special equipment and toolset have been developed and made at the Institute of Thermoelectricity, namely high-output cutting machines “ALTEC 13005M”, “ALTEC 13009”. Parameters and characteristics of both initial TEM and modules are efficiently determined on the generated measuring installations “ALTEC 10002” and “ALTEC 10003”.

Pyrotechnic heat source

Since the figure of merit of TEM is close to limit level, the major directions for efficiency increase of thermoelectric devices is their design improvement and development of new heat sources [2]. A variety of rather stringent requirements is imposed on pyrotechnic compositions intended for use in TECS [17]. Current source should consist of two compositions, namely the main and starting ones. Pyrotechnic compositions should meet the following requirements:

- possess high specific calorific value;
- have predetermined combustion rate to assure the required time characteristics of thermoelectric current source;
- have high physicochemical stability to assure a long storage period of thermoelectric current source;
- easily take fire from initiators;
- release minimum amount of gaseous products on combustion;
- be independent of ambient oxygen;
- possess high stability of thermophysical and mechanical properties in storage.

To the fullest extent these requirements are satisfied by mixtures based on zirconium and barium chromate which were used for the creation of TECS.

Structure and operating principle of TECS

The structure of TECS is presented in Fig. 2. On the internal surface of a thin-walled cylinder case 3 made of aluminium alloy there are eight thermoelectric modules 1 mounted by means of a compound.

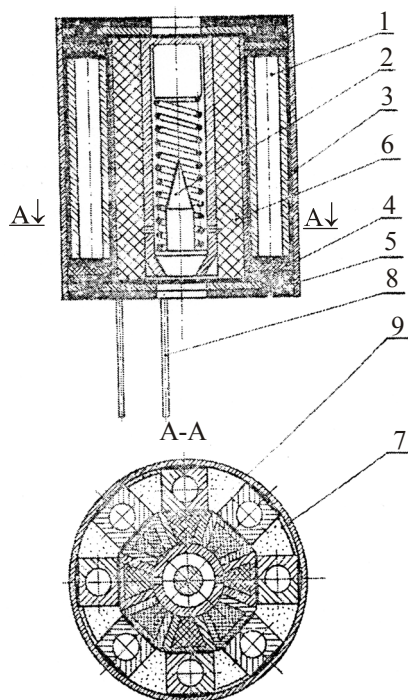

Fig. 2. Structure of TECS.

Conductors 7 connect the modules into a series circuit, the beginning and end of which are connected to leads 8. Chutes 9 made of aluminium alloy are fixed to the internal surfaces of modules by means of a compound. The absence of electrical connection between the modules, the case and chutes is assured by depositing on the respective surfaces of the latter of electrically isolating oxide coatings with the order of thickness 10 μm possessing high mechanical strength and the appropriate thermal conductivity. The volume of conduits is filled with pyrotechnic composition 6. Coaxially arranged inside the TECS is initiator 2 of impact-impression type. On both sides the TECS is covered by lids 4 and 5, the space between them being filled with a compound assuring high mechanical strength of TECS.

The operating principle of TECS is based on direct thermal into electric energy conversion.

The initiator of impact-impression type is actuated due to overload. The flame of percussion cap fires the pyrotechnic composition through the suitable opening in the case of the device. The heat released in this case assures the dynamic process of reaching steady-state mode by TECS and heats the mass of the chutes to temperature close to 600 °C. The heat capacity of the chute mass, alongside with the heat capacity of slag and burnt pyrotechnic composition provides for accumulation of thermal energy required for the work of TECS for a predetermined period. In so doing, the function of heat sink is performed by structural elements of device in which TECS is employed.

Results of testing TECS

Experimental prototypes of TECS were tested on a laboratory setup the electric circuit of which is shown in Fig. 3. An aluminium cylinder of weight about 45 g was used as a heat sink.

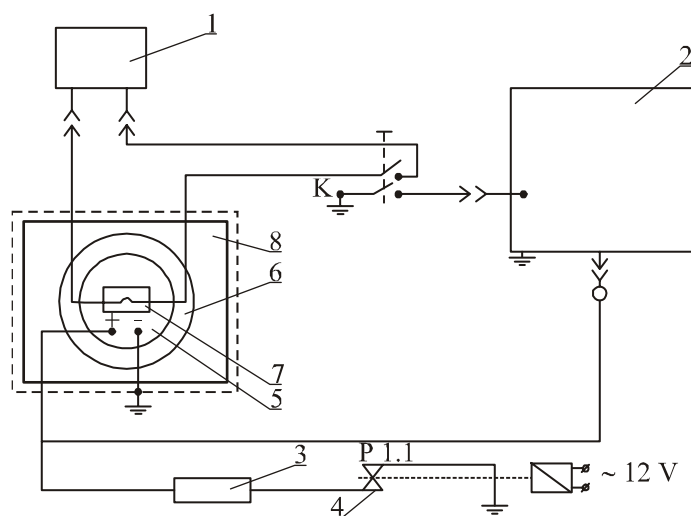

Fig. 3. Electric circuit of a setup for testing TECS.

Fig. 4 shows typical oscilloscope records for the EMF and on-load voltage 1000 Ohm of the experimental prototype of TECS.

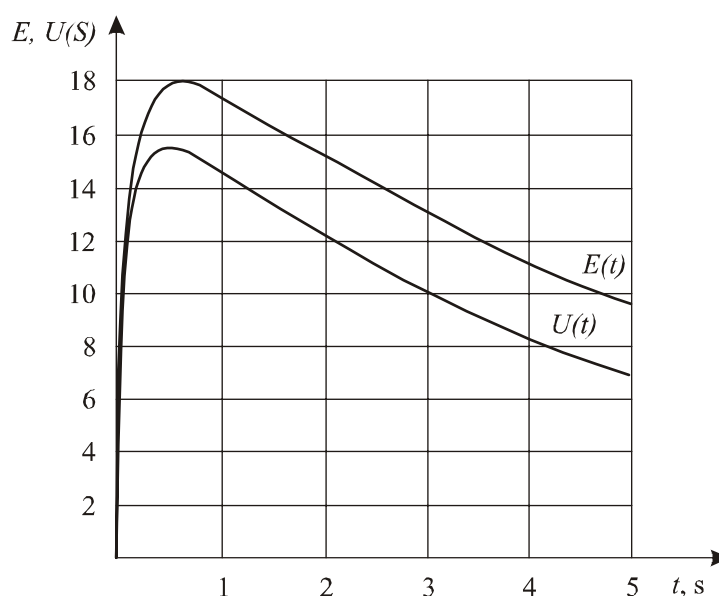

Fig. 4. Oscilloscope records for the EMF and on-load voltage 1 kOhm of TECS.

The basic parameters and characteristics of TECS are presented in Table 1.

Table 1

| № | Parameter or characteristic | Value |
|---|---|--------------|
| 1 | Electric power, W | 0.1 |
| 2 | Electric voltage, V, not less | 10 |
| 3 | Time required to reach the mode, s | 0.1 |
| 4 | Operating time, s, not less | 3 |
| 5 | Operating temperature range, s | -60 – 80 |
| 6 | Operating capacity after the impact of a single shock along the axis with the overload, g | 80000 |
| 7 | Storage life, years, not less | 10 |
| 8 | Overall dimensions: height, mm diameter, mm | 16.5 14.1 |

Conclusions

1. The results of the investigation have proved the undeniable advantages of TECS over similar products with the alternative heat sources.
2. A construction of small-size current source has been created on the basis of enhanced reliability unified thermoelectric module and a pyrotechnic heat source with an impact-impression initiator. The availability of such a current source allows creating new products the application of which in different fields of science and technology has been restricted by the absence of such TECS.

References

1. L.I. Anatychuk, Thermoelements and Thermoelectric Devices, Handbook Naukova Dumka, Kyiv, 1979.
2. A.S. Okhotin, A.A. Yefremov, V.S. Okhotin, A.S. Pushkarsky, Thermoelectric Generators (Atomizdat, Moscow, 1976).
3. E.K. Iordanishvili, Thermoelectric Power Sources (Sovetskoye Radio, Moscow, 1968).
4. L.I. Anatychuk, V.Ya. Mikhailovsky, I.Yu. Ludchak, Experimental Investigations of Thermoelectric Power Source for Gas-Distributing Stations, J. Thermoelectricity 4, 73 – 77 (2008).
5. Thermoelectric Generators [Ed. By A.R.Regel] (Atomizdat, Moscow, 1971).
6. Philip E. Eggers, William E. Gawthrop, James M. Howard, Aerodynamically Heated Thermoelectric Converter for Fuse Control in 20 and 30 mm Projectiles, Record 10 Intersoc. Energy Convers Eng. Conf., Newark, Del., 1975, 735 – 749.
7. Patent of FRG № 12112606.
8. G.K. Kotyrlo, Yu.N. Lobunets, Calculation and Design of Thermoelectric Generators and Heat Pumps (Naukova Dumka, Kyiv, 1980).
9. A.A. Shidlovsky, Fundamentals of Pyrotechnics (Mashinostroyeniye, Moscow, 1977).
10. Pyrotechnics in Rocket and Space Technology [Ed. By N.A. Silin] Mashinostroyeniye, Moscow, 1977.

Submitted 21.05.2011.