



R.G. Cherkez

## ENERGY CHARACTERISTICS OF THERMOELEMENT WITH A DEVELOPED LATERAL HEAT EXCHANGE

R.G. Cherkez

(Institute of Thermoelectricity, 1, Nauky Str.,  
Chernivtsi, 58029, Ukraine)

---

- The results of research on thermoelement with a developed lateral heat exchange working in electrical power generation mode are presented. Based on a physical model, a three-dimensional computer model of generator thermoelement with a developed lateral heat exchange is created and the influence of structural and thermophysical parameters on its energy characteristics is investigated. Possibilities of efficiency increase by 20 to 30% and specific electrical power by 40 to 50% as compared to conventional thermoelements are indicated.

### Introduction

The greatest application has been found by thermoelectric generators [1, 2] that use heat from organic fuel combustion and are based on a classical model of thermoelement of which a module is

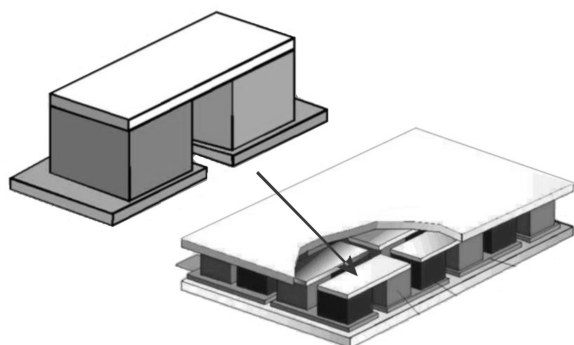

Fig. 1. Schematic of classical thermoelement.

composed (Fig. 1). In this thermal scheme the energy conversion efficiency is insufficient, since the temperature of thermogenerator exhaust gases is close to the hot-junction temperature of thermopile, hence, nearly half the energy of hot gases is not used. Thermoelectric generators made according to a classical scheme have a low efficiency.

To improve the efficiency of thermoelectric power conversion it is

promising to use the lateral surfaces of legs for extraction of low-grade thermal energy from the heat carrier [3]. Due to heat exchange between the heat carrier and the “cold” parts of legs, it enables more thermal energy to be transferred to material and to convert it into electrical energy. Computer calculations of such thermoelement models in a one-dimensional approximation [4] testified the possibility of efficiency improvement by 30%.

However, no research on such thermoelements in a three-dimensional (3-D) case with regard to temperature dependences of material parameters has been ever performed.

The purpose of this work is to create and study a 3-D computer model of generator thermoelement with a developed lateral heat exchange and to determine the influence of structural and thermophysical factors on its energy characteristics.

### Physical model of thermoelement with a developed lateral heat exchange and its mathematical description, problem solution method

Fig. 2 represents a physical model of generator thermoelement comprising  $n$ - and  $p$ -type legs whose material properties change with coordinates, owing to dependence of thermoelectric material

properties on temperature  $T(x)$ . The temperature of heat carrier supplied to the hot side and the lateral surface of thermoelement legs is  $T_h$ , the cold side is thermostated at temperature  $T_c$ . The specific feature of this thermoelement as compared to its classical analog is additional heat supply to the lateral surface of thermoelement legs which permits more heat to be used from the heat carrier. Using this method expands the area of heat exchange between the heat carrier and thermoelement, a greater quantity of heat can be transferred to thermoelement, hence, the efficiency of power conversion is increased. As long as, notwithstanding creation of materials with pre-assigned properties, the figure of merit has not increased during recent years, new ways for efficiency improvement of thermoelectric power conversion are being studied, one of which is creation of new thermal schemes of thermogenerators.

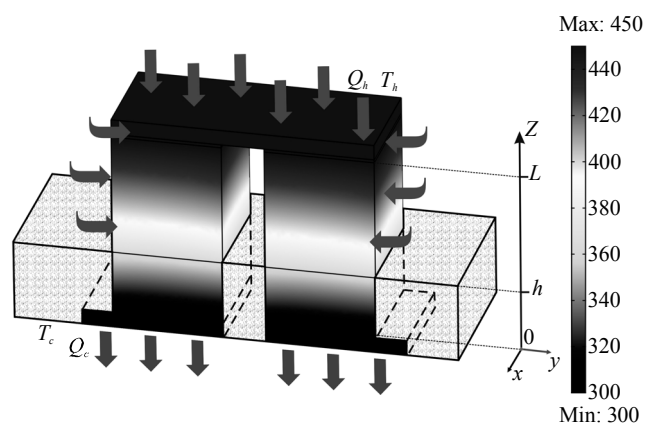

Fig. 2. Schematic of generator thermoelement with a developed lateral heat exchange

Temperature distribution in the leg material  $T$  can be found from the solution of a differential equation of thermal conductivity with account of the temperature dependences of material parameters (1):

$$\nabla \kappa \nabla T + \frac{\vec{i}^2}{\sigma} - \tau \vec{i} \nabla T = 0, \quad (1)$$

where  $\tau$  is the Thomson coefficient;  $\kappa$  is thermal conductivity;  $\sigma$  is electric conductivity;  $\vec{i}$  is vector of electric current density.

The distinguishing feature of this model is the presence of intensive heat exchange with the lateral surface of leg  $S_b$  described by the Newton-Richmann law

$$q|_{S_b} = \alpha_T (T_h - T); \quad (2)$$

$q|_{S_b}$  is heat flux coming to the lateral surface of the leg;  $T_h$  is gas temperature;  $\alpha_T$  is heat exchange coefficient.

For the isolated part of thermoelement leg the following ratio is valid:

$$q|_{S_{is}} = 0. \quad (3)$$

The main problem of study is to find optimal distributions of temperatures, heat fluxes and energy characteristics of thermoelement with a developed lateral heat exchange whereby maximum efficiency is achieved for given cold-junction temperatures  $T_c$ , of heat carrier  $T_h$ .

The problem of reaching maximum efficiency:

$$\eta = \frac{W}{Q_H}, \quad (4)$$

where  $W = Q_H - Q_c$  is electrical power generated by thermoelement,  $Q_H$  is heat supplied to thermoelement,  $Q_c$  is heat which is removed.

Heat supplied to thermoelement will be a sum of heats coming to the hot junction  $Q|_h^k$  and the lateral surface of leg  $Q|_h^b$ :

$$Q_H = Q|_h^k + Q|_h^b, \quad (5)$$

where

$$Q|_h^k = \int_{s_k} \vec{q} d\vec{S}_k, \quad (6)$$

$$Q|_h^b = \int_{s_b} \vec{q} d\vec{S}, \quad (7)$$

where  $q$  is heat current density determined by expression:

$$\vec{q} = \alpha \vec{i} T - k \nabla T. \quad (8)$$

The quantity of heat removed by thermoelement is determined from the formula:

$$Q_c = \int_{s_c} \vec{q} d\vec{S}. \quad (9)$$

### 3-D computer model of thermoelement in Comsol Multiphysics package

The COMSOL Multiphysics program is based on a system of partial-derivative differential equations. There are three mathematical methods for assigning such systems:

- Coefficient form, assigned for the linear and close to linear models;
- General form, for nonlinear models;
- Weak form, for models with partial-derivative equations on the boundaries, edges or for models using conditions with mixed derivatives with time [5].

To calculate the models of thermoelectric elements it is reasonable to use a “weak form” as partial-derivative equations on the boundaries, since they permit the necessary conditions to be assigned on thermoelement surfaces. Using the above mentioned form, a model of conventional (classical) thermoelement was created where heat exchange occurs on its end surfaces. To begin with, the thermoelement geometry was built that includes thermoelement legs, connecting plates, as well as transient layers, to bring the properties of computer model closer to real one. After decomposition of the model by finite element method [6] the thermoelement will acquire the form represented in Fig. 3, where each of model parts is decomposed irrespective of neighbouring components, so the smallest elements were obtained on thin transient elements of thermoelement. Decomposition characteristics are given in Table 1.

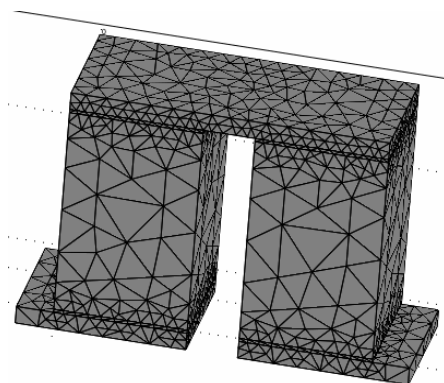

*Fig. 3. Appearance of classical thermoelement after decomposition*

Table 1

*Decomposition characteristics of classical thermoelement model*

Number of degrees of freedom	45140
Number of nodal points	3192
Number of elements	14936
Number of faces	600
Number of surfaces	48
Minimum quality of elements	0.233

Classical model was created to check the conformity of computer model to the models of real investigated thermoelements and to compare their parameters under identical operating conditions. The next step is to assign matrix coefficients that determine isotropy or anisotropy of properties of simulated object and for this case are represented in Table 2. The values of these coefficients were obtained empirically.

Table 2

*Coefficients and their values*

Name	Value
c11	$\kappa + \sigma \cdot \alpha \cdot u + \sigma \cdot \alpha \cdot \alpha \cdot T$
c12	$\sigma \cdot u + \sigma \cdot \alpha \cdot T$
c21	$\sigma \cdot \alpha$
c22	$\sigma$

Two kinds of boundary conditions are used to assign the boundary conditions on thermoelement surfaces:

- derichlet’s boundary conditions (first-type boundary conditions) are the boundary conditions of conventional differential equation or partial-derivative differential equation, where the value of unknown function is determined on the boundary. In the case of partial-derivative equation the boundary conditions are assigned on a certain outline or surface, hence it can be a function determined on this outline or surface;
- the Neumann boundary conditions (second-type boundary conditions) are the boundary conditions of conventional differential equation or partial-derivative differential equations, which determine a derivative of the sought-for function at the area boundary.

Both for conventional thermoelement and for thermoelement with a developed lateral heat exchange, Derichlet’s boundary conditions were used on the cold side for temperature and potential, and the hot side was assigned by the Neumann conditions (dependence on heat carrier temperature and heat exchange coefficient).

To describe the properties of materials used in the model, for each model elements the values of kinetic coefficients are written:  $\alpha$ ,  $\sigma$ ,  $\kappa$  are thermoelectric coefficient, electric and thermal conductivity which are functions of temperature  $T$  and assigned by polynomials given in Table 3, where the second column corresponds to interconnect properties, the third column- to heat spreader properties; in Tables 4 and 5 are written the properties of  $n$ - and  $p$ -type legs for material based on  $Bi_2Te_3$  (Fig. 4).

Table 3

Properties of interconnects and heat spreader

$\alpha$	0	0
$\sigma$	60000000	500000
$\kappa$	400	4000

Table 4

Properties of n-type leg

$\alpha_n$	$1.03 \cdot 10^{-6} \cdot (-184.14286 + 2.14929 \cdot T - 0.00383 \cdot T^2 + 2 \cdot 10^{-6} \cdot T^3)$
$\sigma_n$	$100 \cdot (4528.57143 - 13.78929 \cdot T + 0.01293 \cdot T^2)$
$\kappa_n$	$0.1 \cdot (127.20238 - 0.73409 \cdot T + 0.00151 \cdot T^2 - 8.88889 \cdot 10^{-7} \cdot T^3)$

Table 5

Properties of p-type legs

$\alpha_p$	$1.03 \cdot 10^{-6} \cdot (369.71429 - 2.18595 \cdot T + 0.00729 \cdot T^2 - 7.3333 \cdot 10^{-6} \cdot T^3)$
$\sigma_p$	$100 \cdot (7856.90476 - 34.8127 \cdot T + 0.05638 \cdot T^2 - 3.11111 \cdot 10^{-5} \cdot T^3)$
$\kappa_p$	$0.1 \cdot (70.80476 - 0.31257 \cdot T + 0.000449524 \cdot T^2)$

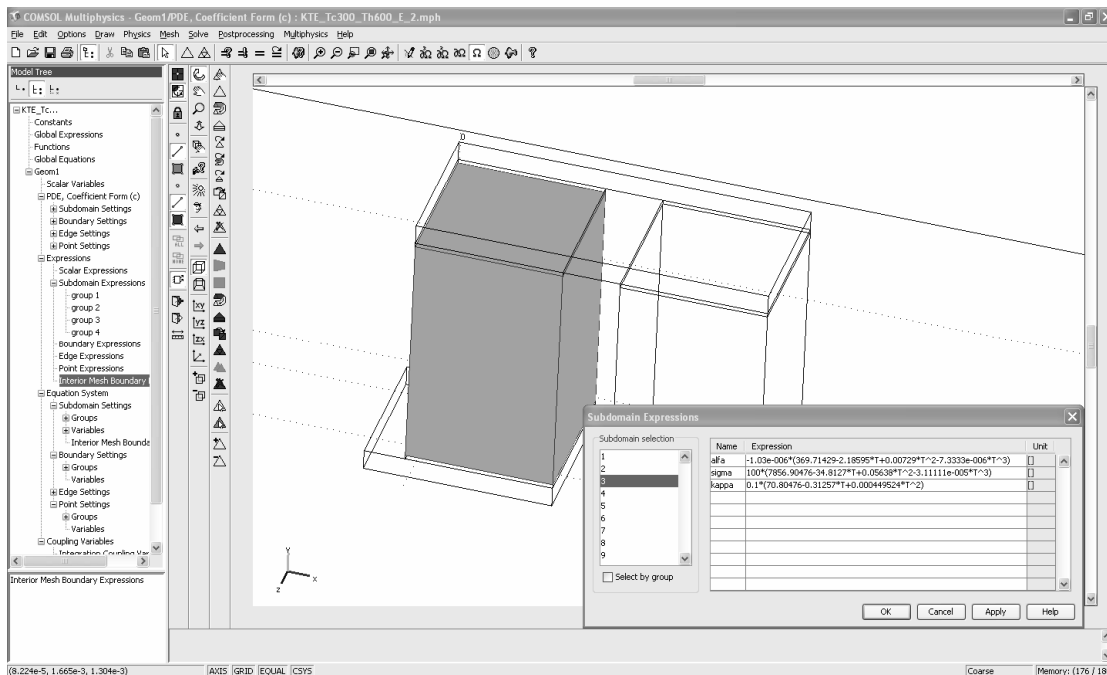

Fig. 4. Example of assignment of object properties in COMSOL Multiphysics graphical interface.

Calculation of the energy parameters requires introduction of additional equations to determine current and heat fluxes supplied to and rejected from thermoelement (Table 6). In the course of subsequent calculations, using integration by the surface, we find the values of current passing through thermoelement, as well as the input and output heat fluxes necessary to determine the energy characteristics of thermoelement, in particular, the efficiency and electrical power.

Finite-element method in the medium of Comsol Multiphysics application program package was used to perform thermoelement simulation for materials based on  $Bi_2Te_3$  with maximum thermoelectric figure of merit  $2.8 \cdot 10^{-3} K^{-1}$  at room temperature. The contact and connection

resistances, the temperature dependences of material kinetic coefficients were taken into account. The influence of heat exchange conditions, structural parameters of thermoelement and lateral surface insulation on the energy characteristics was studied.

*Table 6*

*Formulae employed*

Variable	Value
$I_x$	$-\sigma \cdot u_x - \sigma \cdot \alpha \cdot T_x$
$I_y$	$-\sigma \cdot u_y - \sigma \cdot \alpha \cdot T_y$
$I_z$	$-\sigma \cdot u_z - \sigma \cdot \alpha \cdot T_z$
$I_n$	$n_x \cdot I_x + n_y \cdot I_y + n_z \cdot I_z$
$Q_x$	$-\kappa \cdot T_x - \alpha \cdot T \cdot \sigma \cdot (u_x + \alpha \cdot T_x)$
$Q_y$	$-\kappa \cdot T_y - \alpha \cdot T \cdot \sigma \cdot (u_y + \alpha \cdot T_y)$
$Q_z$	$-\kappa \cdot T_z - \alpha \cdot T \cdot \sigma \cdot (u_z + \alpha \cdot T_z)$
$Q_n$	$n_x \cdot Q_x + n_y \cdot Q_y + n_z \cdot Q_z$

### Computer study of the energy characteristics of thermoelements based on $Bi_2Te_3$ material

For the calculation we used dependences of material parameters  $\alpha(T)$ ,  $\sigma(T)$ ,  $\kappa(T)$  obtained by least-squares approximation and given in Fig. 5. For  $n$ -type leg the thermoEMF maximum falls on temperature close to 400 K, the electrical conductivity has a pronounced minimum at 500 K, the thermal conductivity grows with a rise in temperature. For  $p$ -type leg a similar situation is observed.

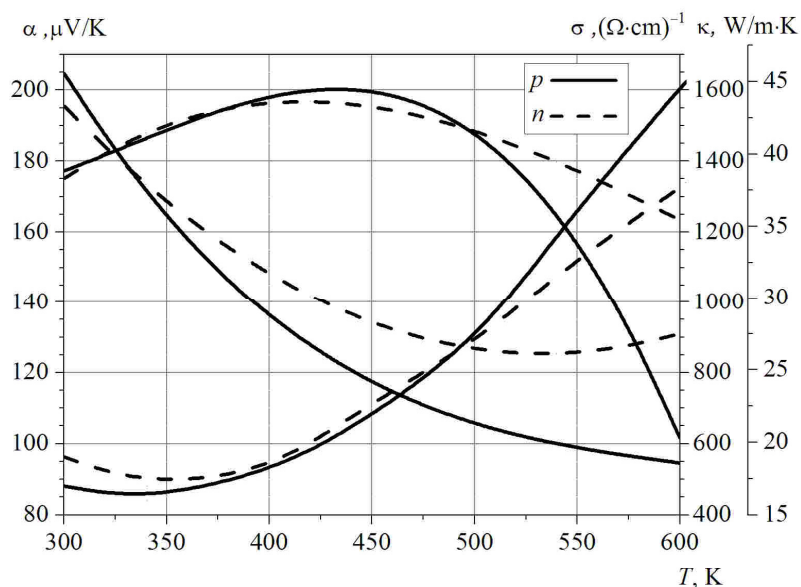

*Fig. 5. Temperature dependence of thermoEMF, the electrical and thermal conductivity.*

The thermoelements were calculated by the following algorithm:

- thermoelement division by finite element method;
- assignment of the boundary conditions on thermoelement surfaces (temperature, potential);
- determination of EMF generated by thermoelement;
- return to the boundary conditions, assignment of electrical resistance;

- repeated calculation of the model, determination of temperature distribution;
- integration of surfaces with respect to current and heat fluxes, determination of their values, calculation of electrical power generated by thermoelement;
- calculation of thermoelement efficiency with the use of values obtained in the previous items.

Fig. 6 shows a plot of efficiency and power of classical thermoelement versus current passed through it for different hot side temperatures. As we see from the plot, the efficiency and electrical power maxima are somewhat displaced relative each other in all three cases. The efficiency grows at lower temperatures, but its maximum does not achieve the values obtained at higher temperatures. Maximum efficiency is achieved at hot-junction temperature of thermoelement close to 500 K and makes 6.15% at current 1.8 A. As regards the electrical power, in all represented cases there is a uniform change of values, the power maximum at temperature 650 K is 0.14 W at current 2.53 A.

Comparison of the results obtained to the results of experimental studies of classical thermoelements showed approximate values with a difference of 10 to 15%.

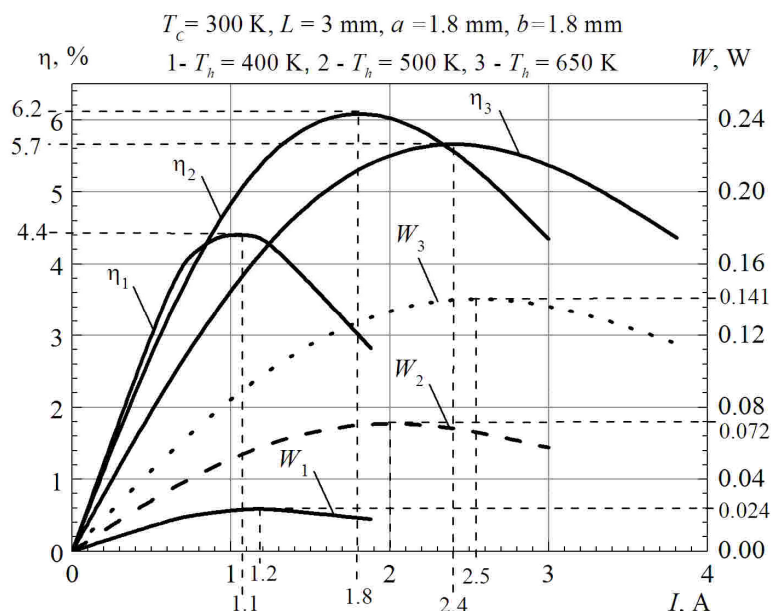

Fig. 6. Results of calculation of a classical thermoelement.

For a thermoelement with a developed lateral heat exchange the calculation procedure and equations employed are similar to classical thermoelement case. The main distinction of the models is the use of a lateral surface of leg for additional heat abstraction from the heat carrier as one of the ways of improving the efficiency of thermoelectric power converter.

The specific feature of a computer model of thermoelement with a developed lateral heat exchange is separation of thermoelement legs into parts. For one of the parts the surface will be completely thermally insulated (like in the case of a conventional thermoelement), to the surface of the other part heat is supplied by the same law as to the hot junction. The total heat flux that will be further used for calculation of the energy characteristics is now a sum of components: heat flux to the hot junction of thermoelement and heat flux to the lateral surface of leg.

Having performed calculation of thermoelement, for instance, for cold-junction temperature  $T_c = 300 \text{ K}$ , heat source temperature  $T_h = 900 \text{ K}$ , at  $L = 3 \text{ mm}$ ,  $a = 1.8 \text{ mm}$ ,  $b = 1.8 \text{ mm}$ ,  $\alpha_T = 0.010 \text{ W/cm}^2 \cdot \text{K}$  for convection to the hot side of thermoelement, and  $\alpha_T = 0.005 \text{ W/cm}^2 \cdot \text{K}$  for convection to the lateral surface of legs, at insulation height  $L/2$  we obtain the distribution of temperatures shown in Fig. 7.

As is evident from the figures, due to additional heat input to the lateral surface of thermoelement legs, the isothermal surfaces are somewhat bent towards temperature increase (Fig. 8), the isothermal surfaces in the isolated part of the leg change their shape only slightly. The resulting graphical distribution of isotherms corresponds to thermal processes in thermoelement which points to correctness of problem solution.

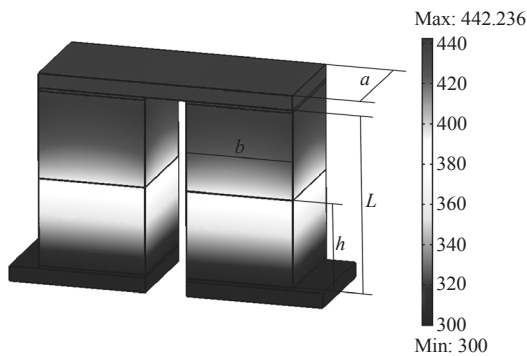

*Fig. 7. Temperature distribution  $T$  in thermoelement with a developed lateral heat exchange.*

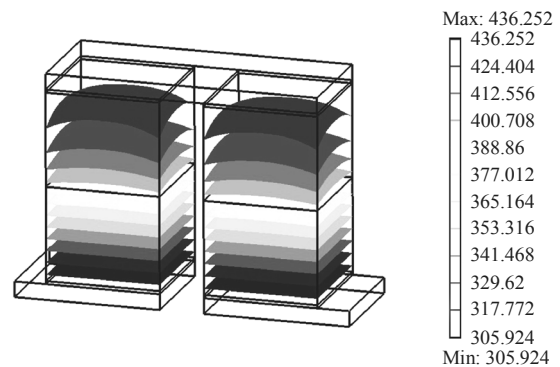

*Fig. 8. Isothermal surfaces in thermoelement with a developed lateral heat exchange.*

Results of calculation of a three-dimensional computer model of thermoelement with a developed lateral heat exchange

Results of calculation of a 3-D model constructed in Comsol Multiphysics package are represented in Fig. 9, where the efficiency and power are shown as a function of insulation height of the lateral leg surface for heat carrier temperature 700 K. The ratio between the efficiency levels of thermoelement with a developed lateral heat exchange for leg insulation height  $\frac{1}{2}L$  and classical thermoelement (lower dashed horizontal line) is nearly 36%. The electrical power is 77% higher than that of classical thermoelement. The right vertical scale in the figure indicates the hot-junction temperature of thermoelement which, in turn, is the highest in its volume. The difference in the hot-junction temperatures of thermoelements is nearly 60 K in favour of thermoelement with a developed lateral heat exchange which testifies to better heat rejection from the heat carrier, hence to better device efficiency.

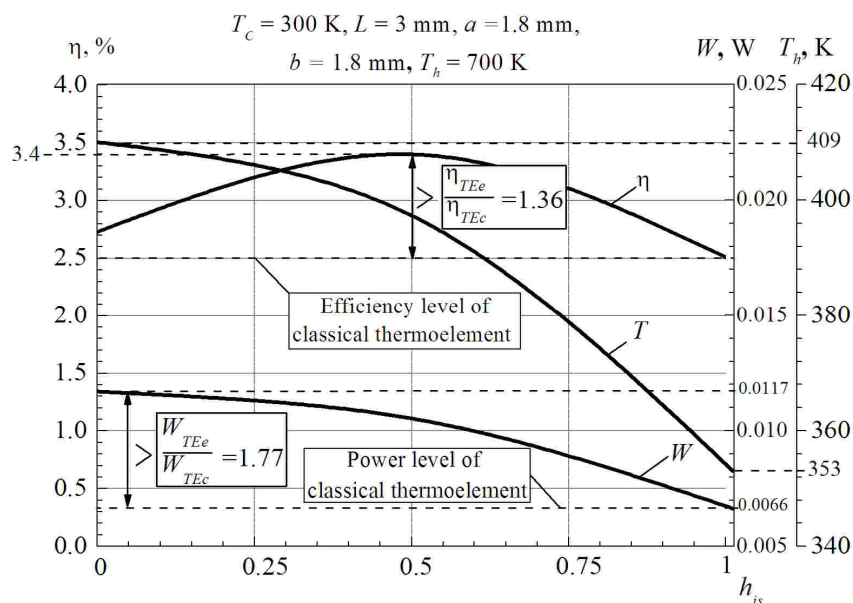

*Fig. 9. Result of calculation of thermoelement with a developed lateral heat exchange for heat carrier temperature  $T_h = 700$  K.*



Fig. 10 represents calculations of thermoelement with a lateral heat exchange, like in the former case, but at heat carrier temperature 900 K. The efficiency gain is nearly 28%, the power is higher by a factor of 1.56. For this thermoelement at heat carrier temperature close to 900 K it is reasonable to use leg insulation no less than 0.05 of leg height, since at lower insulation height the energy characteristics of this type of thermoelements are inferior to classical analogs.

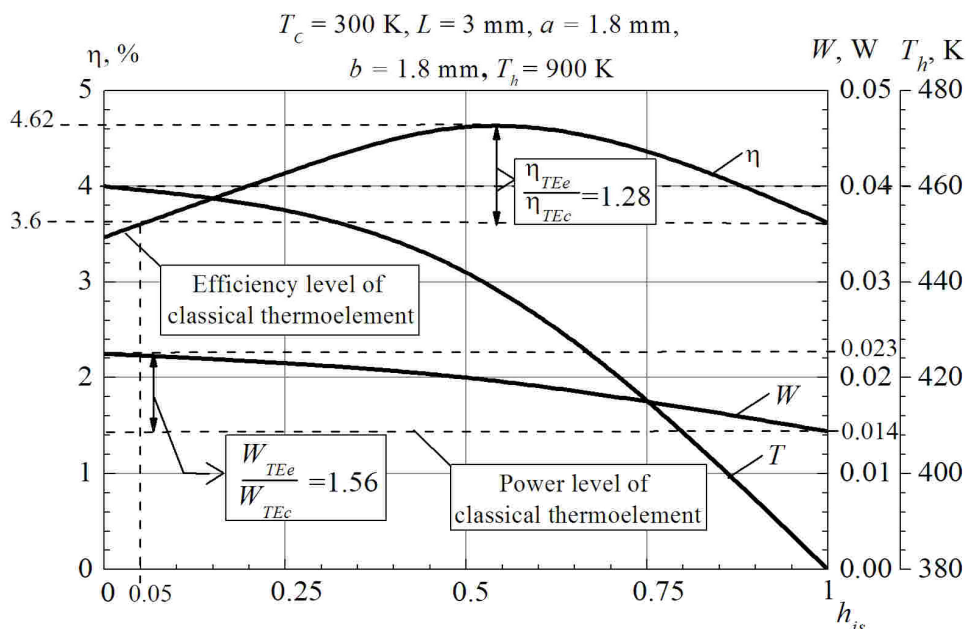

Fig. 10. Result of calculation of thermoelement with a developed lateral heat exchange for heat carrier temperature  $T_h = 900 \text{ K}$ .

Results of calculation of the energy characteristics for inlet gas temperature 1100 K (exhaust gas temperature of petrol engine) are given in Fig. 11. The efficiency is improved by 22%, the power is about 42% higher than that of classical analog, the hot side temperature is 100 K higher. The thermoelement is efficient with the use of insulation no less than 0.15 of leg height.

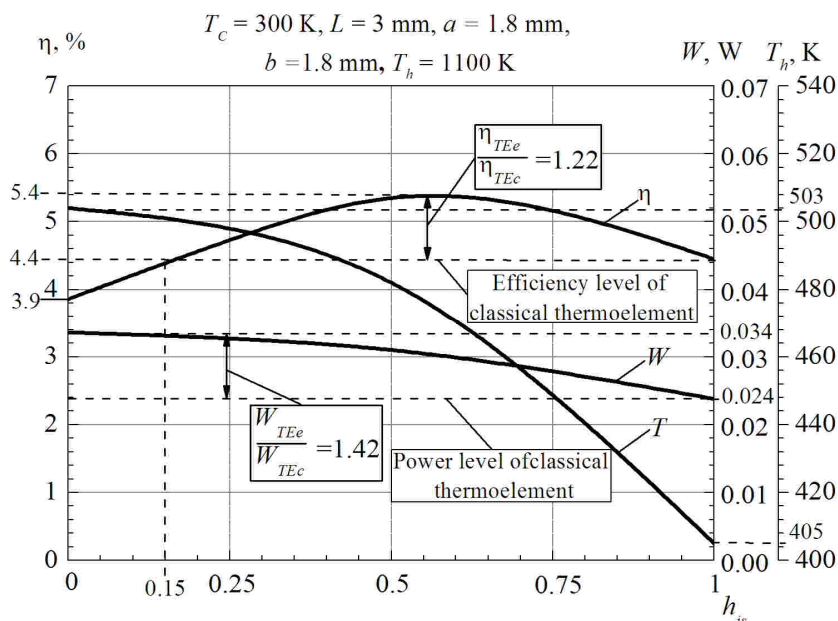

Fig. 11. Result of calculation of thermoelement with a developed lateral heat exchange for heat carrier temperature  $T_h = 1100 \text{ K}$ .

## Conclusions

1. A 3-D model of thermoelement with a developed lateral heat exchange in electrical power generation mode is presented.
2. For materials based on  $Bi_2Te_3$  the effect of legs height, legs insulation and electrical current values on the energy characteristics of thermoelement, namely the efficiency and generated electrical power, is studied.
3. In the case of using materials based on  $Bi_2Te_3$  and thermoelement operation at the initial heat carrier temperature 900 K with thermostated cold junctions at temperature 300 K, comparison to conventional thermoelements in terms of thermodynamic efficiency of power conversion has shown the possibility of efficiency increase by 20 to 30% and generated power by 40 to 50%.

The Author is grateful to L.I. Anatyshuk for helpful discussions of the physical model and contribution to performance of this work.

## References

1. L.I. Anatyshuk, *Thermoelements and Thermoelectric Devices* (Kyiv: Naukova Dumka, 1979), p. 768.
2. G.K. Kotyrlo, Yu.N. Lobunets, *Calculation and Design of Thermoelectric Generators and Heat Pumps* (Kyiv: Naukova Dumka, 1980), p. 327.
3. *Method for Improving the Efficiency of Thermoelectric Generator (Cooler)*. USSR Certificate of Authorship, №144883, I.V. Zorin, Filed 22.06.1961, Published 18.10.1968
4. R.G. Cherkez, Thermoelements with the Internal and Lateral Heat Exchange, *J. Thermoelectricity* **1**, 71-79 (2003).
5. G.V. Biryulin, *Thermophysical Calculations in Finite-Element COMSOL Package / FEMLAB: Guidance Manual* (Saint-Petersburg: State University of Information Technologies, Mechanics and Optics, 2006), p. 78.
6. L. Segerlind, *Use of Finite Element Method* (Moscow: Mir, 1979), p. 392.
7. L.I. Anatyshuk, R.G. Cherkez, Permeable Thermoelement in Electric Power Generation Mode, *J. Thermoelectricity* **2**, 35-46 (2003).
8. L.I. Anatyshuk, L.N. Vikhor, Generator Modules of Segmented Thermoelements, *Energy Conversion and Management* **50**(9), 2366-2372 (2009).
9. T. Calliat, J.-P. Fleurial, G.J. Snyder, A. Zoltan, D. Zoltan and A. Borshchevsky, Development of High Efficiency Thermoelectric Unicouple for Power Generation Applications, *Proc. of the XVIIIth International Conf. on Thermoelectrics* (Baltimore, USA, 1999), p. 473-476.
10. L.I. Anatyshuk, O.J. Luste and V.Ya. Mykhailovsky, Sectional Organic-Fueled Thermoelectric Generators, *J. Thermoelectricity* **4**, 20-25 (2005).

Submitted 07.05.2011.