

**L.I. Anatyshuk, V.Ya. Mykhailovsky, A.F. Semizorov,
L.T. Strutynska, A.F. Kashtelyan, N.V. Maksimuk**

Institute of Thermoelectricity
NAS and MES of Ukraine, 1, Nauky Str.,
Chernivtsi, 58029, Ukraine

CATALYTIC HEAT SOURCE WITH A THERMOELECTRIC GENERATOR

The results of research and development of a self-contained catalytic heat source with a thermoelectric generator used to achieve improved efficiency and ecological purity of the catalytic combustion of gas organic fuels are presented. An estimate is made and comparative analysis of characteristics of catalytic heat sources is performed and the ways for improving their efficiency are determined. Construction of a diffusion catalytic heat source with a thermal generator is described with the results of experimental research and parameter optimization, as well as the rational application areas of such heat sources are given.

Key words: catalytic heat source, thermoelectric generator.

Introduction

At the present time flame combustion of organic fuel is the main method of thermal energy production for commercial and domestic use. In so doing, the efficiency of using fuel chemical energy is rather low, as long as heat losses with such fuel combustion in a number of cases can reach 30 to 40 %. Moreover, the use of flame combustion deteriorates the ecological parameters. The content of toxic substances (nitrogen and carbon oxides) in fuel combustion products can reach 20 to 50 mg/m³ and 100 to 500 mg/m³, respectively [1, 2]. This is several orders higher than the norms of near-earth maximum allowable concentrations of respective substances in the populated area (Table 1) [3].

For gas fuel combustion and heat production use is also made of infrared flameless radiators whose radiation spectrum is 0.5 to 3 μm, the temperature of ceramic nozzle where fuel is burnt reaches 800 to 1200 °C [4]. Such devices retain the disadvantages of flame burners, so they are of limited application.

Table 1

Maximum allowable concentrations and relative hazard figures of substances

Substance	Maximum one-time concentration, mg/m ³	Average daily concentration, mg/m ³	Relative hazard
Carbon oxide	5	3	1
Hydrocarbons	5	1.5	2
Nitrogen oxide	0.4	0.06	50
Nitrogen dioxide	0.09	0.04	75

Long-wave radiators with a lower temperature of heat-releasing surface (200 – 600 °C) are mostly used for heating shops, hangars, gymnasiums, etc. [5]. They also employ flame combustion of gas. Such heaters need electric energy for their operation, which restricts their use for a self-contained

supply of consumers with thermal energy.

In terms of ecological purity and safety the most promising method is catalytic flameless combustion of gas fuel in devices with separate fuel and air delivery to combustion area [6]. Fuel combustion on the catalyst is realized at a temperature of 300 to 600 °C without considerable air excess, which allows reduction of heat losses and considerable reduction of CO and NO_x [5]. In such heat sources gas comes to the catalyst under little pressure, and the air necessary for combustion penetrates porous catalyst bed by natural diffusion. The amount of input air is not controlled, so maximum gas flow rate under natural air diffusion is limited by catalyst value 0.25 g/cm^3 . In this connection, diffusion catalytic heat sources have a low calorific power and large dimensions.

Catalytic heat sources with a separate delivery of reagents are used for heating amenity spaces, equipment, devices, and drying paint coatings [7-11]. Space heating is done by natural circulation of air heated by catalyst. In so doing, fuel combustion products H_2O and CO_2 remain in the room which deteriorates the ecological parameters of heated space and calls for its efficient ventilation. The purpose of this work is to increase the efficiency and improve the ecological parameters of flameless catalytic heat sources with a separate delivery of combustible gas and fuel to the catalyst.

Results of development and research on parameters of a catalytic heat source with a thermoelectric generator

Increase in fuel combustion efficiency and calorific power of catalytic heat sources with a separate delivery of reagents can be achieved by intensification of mass exchange processes in catalyst bed [12]. A number of factors that affect gas mixture flow in porous catalyst bed have been determined:

1 – gas pressure due to forced delivery of combustible gas directed from the internal catalyst surface to the external (radiant) surface and the resulting transverse eddy agitation of gases in catalyst bed;

2 – diffusion of gases, in particular combustion oxygen, which is more intensive as compared to other gases, as long as oxygen burns out in catalyst bed and, as a result, high concentration gradient of O_2 is retained (about 21 % near to catalyst radiant surface and close to zero near the internal surface);

3 – temperature convection of hot gases (O_2 , CO_2 , H_2O , N_2) moving in catalyst bed and along the catalyst vertical radiant surface.

A schematic of gas flow in a catalytic heat source is represented in Fig. 1.

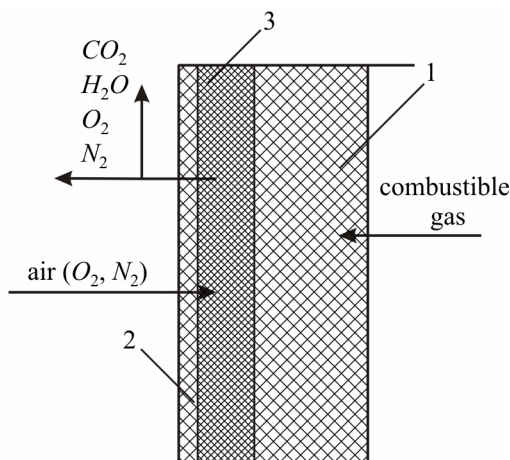

Fig. 1. Schematic of gas flow in a catalytic bed of heat source: 1 – catalyst; 2 – catalyst radiant surface; 3 – combustion area.

It is rather difficult to control oxygen diffusion to catalyst bed, since it depends on O_2 concentration gradient over the thickness of operating catalyst bed. It should be taken into account here that oxygen diffuses to catalyst bed opposite to combustion products, which reduces its concentration in combustion area. Oxygen concentration is also reduced due to the fact that atmospheric nitrogen does not burn out and its concentration in catalyst surface layers is higher than in the air, which further reduces the concentration of O_2 diffusing into catalyst bed.

Special investigations have established that forced air cooling of catalyst radiant surface brings about considerable increase of oxygen concentration over the thickness of catalyst bed (Fig. 2, curves 1, 2). Hydrocarbon concentration in catalyst bed is reduced accordingly (curves 3, 4). It should be noted that a reduction in combustible gas concentration occurs not as a result of its dilution by other gases, but due to increase in the specific amount of combustible gas. For the investigated composition of (Co-Cr-Ni-Pd/SiO₂) catalyst the amount of burnt gas (propane-butane) is increased from 0.25 g/cm³ to 0.35 g/cm³ of the catalyst. In so doing, the catalyst temperature in combustion area is increased by 30 to 50 °C, which finally allows increasing the calorific power of catalyst volume unit by a factor of 1.2 to 1.3.

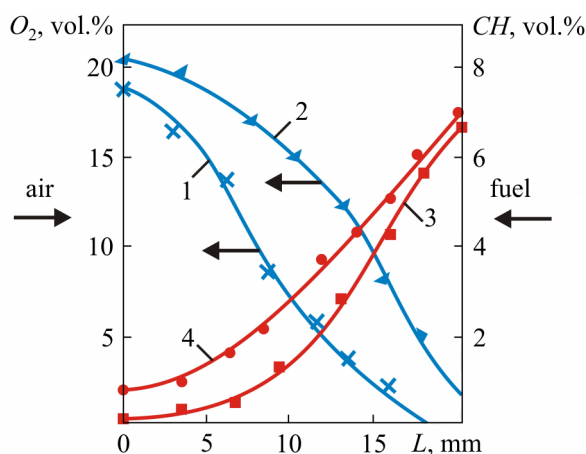
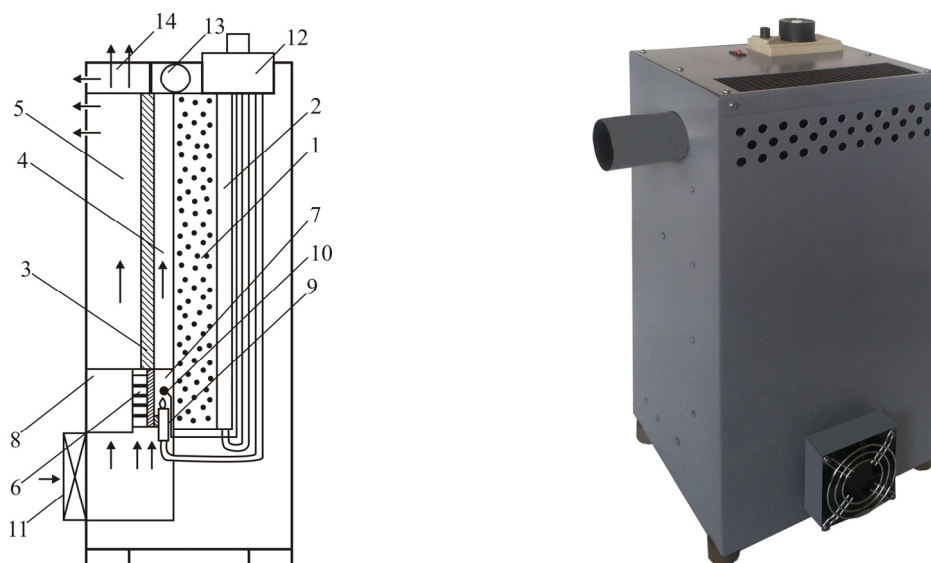

Fig. 2. Concentration profile of oxygen (1, 2) and combustible gas (3, 4) over the thickness of catalyst bed (L) with a natural air diffusion to catalyst bed (1, 4) and forced air cooling (2, 3).

The results of research have been implemented in a concrete construction of a catalytic heat source using separate delivery of reagents to the catalyst and forced air cooling of catalyst radiant surface via electric fan powered from thermoelectric generator. The schematic and outside view of the 1 kW catalytic heat source are given in Fig. 3.

Catalytic heat source consists of a catalyst 1, distribution gas chamber 2 and heat sink 3 that has vertical fins 4 for heat removal from the catalyst and fins 5 for heating the air that heats the space. Arranged in the lower part of heat sink 3 is thermoelectric generator 6 that has the hot 7 and cold 8 heat sinks.

The electric power of thermal generator is 1.5 – 2.5 W. A start-up burner 9 with thermocouple 10 is placed between the fins of the hot heat sink. Forced air delivery for gas combustion and space heating is done by electric fan 11 powered from thermal generator 6. Start-up and control of the catalytic heat source operation is done through gas automation 12. The upper part of the heat source accommodates collector 13 for the removal of gas combustion products to the environment and collector 14 for heated air outlet.



*Fig. 3. Schematic and outside view of gas-fueled catalytic heat source with a thermoelectric generator:
1 – catalyst; 2 – distribution chamber; 3, 4, 5 – air heat sink; 6 – thermal generator;
7 – generator hot heat sink; 8 – generator cold heat sink; 9 – start-up burner; 10 – thermocouple;
11 – fan; 12 – gas automation; 13, 14 – collectors.*

The specific feature of the elaborated catalytic heat source is that air flow created by the fan is distributed into two flows. Air necessary for gas combustion passes between fins 4 of heat sink 6 to catalyst surface, and then is removed through collector 13 and chimney to the environment together with combustion products. The second air flow moving between fins 5 of heat sink 6 is heated and in its pure form (not contaminated with combustion products) it comes through collector 14 for space heating.

The results of experimental research on parameters of a catalytic heat source with a thermal generator are given in Fig. 4.

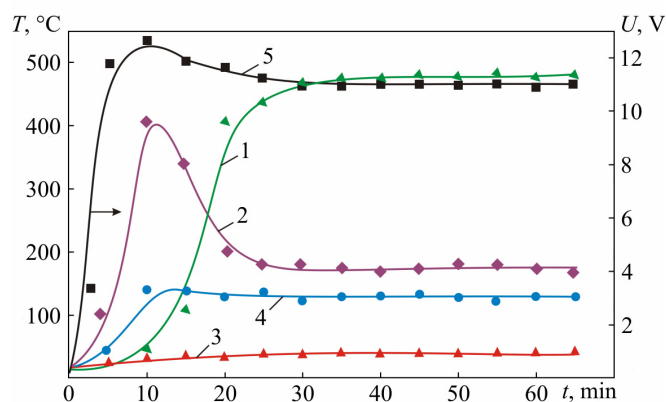

Fig. 4. Time dependence of catalyst temperature (1, 2), thermal generator cold heat sink temperature (3), hot heat sink temperature (4) and thermal generator voltage (5).

It is obvious that the time dependence of catalyst temperature is of complicated nature. In the initial operating period the temperature of lower catalyst part with a start-up burner rises quickly (curve 2) and passes through the maximum within 370 to 400 °C. On achievement of maximum temperature in the lower catalyst part, there is quick temperature rise in the upper catalyst part (curve 1) and is stabilization on the level of 450 – 480 °C. At such catalyst the temperature process of thermal generator hot heat sink is 130 to 140 °C (curve 4), cold heat sink – 30 to 40 °C (curve 3), and

the generator voltage output is 11 to 11.5 V (curve 5)

The electric power of thermal generator with temperature difference between the hot and cold sides 90 to 100 °C is on the level of 2.0 to 2.5 W. This is enough for power supply of electric fan used for forced air cooling of catalyst radiant surface and heated air delivery for space heating. Thus, the optimal rate of air flow in heat sink channels for heat removal from the catalyst is 1 m/s, the hot air temperature for space heating is 70 to 90 °C, and the temperature of combustion products removed by chimney to the environment is 100 to 110 °C.

Conclusions

The use of forced air delivery to the radiant surface of a catalyst of diffusion heat source increases considerably oxygen concentration in catalyst bed, which allows increasing the calorific power of catalyst unit volume by a factor of 1.3 on retention of 100 % completeness of gas fuel combustion. The use of thermoelectric generator assures autonomous delivery of thermal energy to consumers and improves the ecological parameters of heated spaces.

Catalytic heat source with a thermoelectric generator can be used for heating of living spaces and workrooms, greenhouses, garages, trading kiosks, hangars, etc.

References

1. T.B. Janheman, The Development of Atmospheric Burners with Respect to Increasing Emission Rectification, *Proceedings of First European Conference on Small Burner Technology and Heating Equipment*, Vol. 1, P. 23 – 34 (Zurich, September, 25-26, 1996).
2. V.A. Kirillov, N.A. Kuzin, and A.V. Kulikov, The Use of a Catalytic Method for Oxidation of Hydrocarbon Gases for Heat Production in Residential-Grade Thermal Engineering, *Thermal Engineering* **1**, 18 – 22 (2000).
3. V.A. Malyarenko, *Power Plants* (Kharkiv: Saga, 2008), 133 p.
4. Yu.P. Sosnin, U.N. Bukharki, *Household Ovens, Fireplaces and Water Heaters* (Moscow: Stroiizdat, 1984), 368 p.
5. V.Ya. Mykhailovsky, The Prospects of Using Catalytic Sources of Heat and Electricity, *Reports of the National Academy of Sciences of Ukraine (Dopovidi NANU)* **4**, 111 – 115 (2002).
6. V.Ya. Mykhailovsky, Catalytic heat and electricity generators as the way to optimal utilization of hydrocarbon fuel energy, *Journal of Thermoelectricity*, **2**, 3 – 11 (2001).
7. V.Ya. Mykhailovsky, Thermoelectric microgenerators with catalytic propane-butane combustion, *Journal of Thermoelectricity*, **4**, 83 – 86 (2002).
8. L.I. Anatychuk, V.Ya. Mikhailovsky, L.T. Strutinskaya, Catalytic generators of thermal and electric energy on gaseous fuel, *Journal of Thermoelectricity*, **4**, 72 – 80 (1999).
9. L.I. Anatychuk, Rational areas of investigation and application of thermoelectricity, *Journal of Thermoelectricity*, **1**, 3 – 14 (2001).
10. L.I. Anatychuk, Current status and some prospects of thermoelectricity, *Journal of Thermoelectricity*, **2**, 7 – 20 (2007).
11. V.Ya. Mikhailovsky, Heat Sources with Catalytic Combustion of Hydracarbons for Thermoelectric Generators, *Journal of Thermoelectricity*, **1**, 51 – 58 (1993).
12. V.Ya. Mykhailovsky, Organic-Fueled Thermoelectric Generators, *Thesis for a Degree of Doctor in Physics and Mathematics* (Chernivtsi, 2007), 315 p.

Submitted 14.08.2013.