

S.F. Zaporov



S.F.Zaporov

Institute of Thermoelectricity of the NAS and MES of Ukraine,
1 Nauky str., Chernivtsi, 58029, Ukraine

**COMPARATIVE ANALYSIS OF THE EFFICIENCY
OF CUTTING BI-TE-BASED THERMOELECTRIC MATERIAL
USING ELECTRIC EROSION METHOD AND
WIRES WITH BOUND ABRASIVE**

The problem of quality enhancement of thermoelectric cooling modules and generator modules whose legs comprise Bi_2Te_3 -based semiconductor thermoelectric material continues to be relevant. On the one hand, quality enhancement and cost reduction of thermoelectric modules is attained by design solutions, on the other hand, by selection of manufacturing process and maintenance of the achieved reliability level in operation. The process of manufacturing semiconductor thermoelectric legs of n - and p -types is adequately tried and tested, and quality here is primarily assured by the level of technological equipment and staff qualification. Comparative analysis is performed of Bi_2Te_3 -based thermoelectric material dimensional processing using electric spark method and diamond-coated wires. The optimal methods for cutting thermoelectric material (TEM) into discs and legs providing for the best quality with retention of high throughput are determined. The advantage of cutting method using a wire with bound abrasive is demonstrated.

Key words: TEM processing methods, TEM processing tools, benefits and drawbacks.

Introduction

In the manufacture of thermoelectric module legs (half-elements) the following process flowchart is widely used:

- preparation of thermoelectric material ingots;
- cutting of ingots into discs and discs into half-elements of n - and p -type thermoelectric materials by one of defect-free methods (electric erosion method with a wire electrode or mechanical method using a wire with bound or free abrasive, diamond discs).

Thermoelectric material cutting is associated with damaged layers. The properties of damaged layers are essentially different from the properties of the main material. These layers have a lot of defects, owing to which the figure of merit of thermoelectric material in the near-surface layer is considerably lower than in the bulk. Thus, each of the resulting legs is a parallelepiped enclosed by surface layer of material with degraded performance.

The purpose of the work is comparative analysis of thermoelectric material dimensional processing by two methods (electric erosion and diamond-coated wire), their advantages and shortcomings.

Electric erosion processing

Electric erosion processing is a controlled destruction of material by the electric discharges formed as a result of pulsed current flow between electrodes 1, 2 (Fig. 1) that are in the immediate vicinity from each other in liquid dielectric medium, that is, material processing through electric erosion. As a result of these

discharges, microparticles are knocked out of material to be taken away from the interelectrode gap by dielectric flush. Moreover, a dielectric acts as a catalyst of decay process, since at high discharge temperature in the zone of erosion it is vaporized. These methods include electric pulse, electric contact, high-frequency electric spark and electric spark processing.

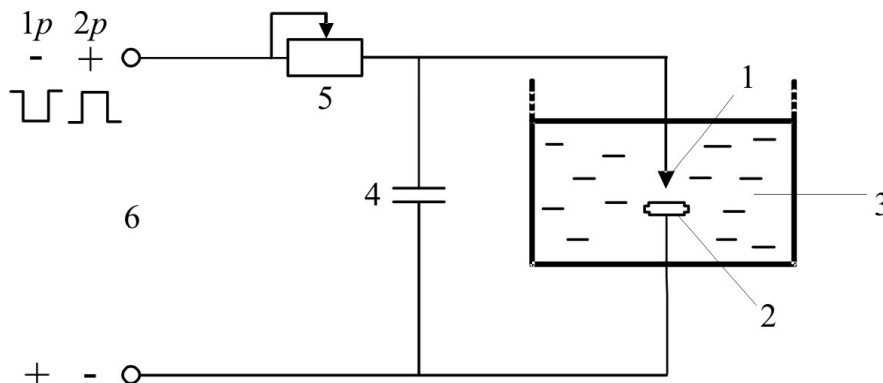

Fig. 1. Schematic of electric erosion processing of material:
 1 – electrode tool, 2 – work material, 3 – discharge environment,
 4 – capacitor, 5 – rheostat, 6 – supply source,
 1p – electric spark processing mode, 2p – electric pulse processing mode.

For electric pulse processing electric pulses of long duration (500 – 10000 μ s) are used, resulting in arc discharge. Electric pulse processing is reasonable to be used for primary machining of dies, turbine blades, profiled parts of heat-resistant alloys. This kind of processing is not used for thermoelectric materials due to very large depth of layers damage.

Electric contact processing is based on local heating of a billet at point of contact to electrode tool and removal of softened or even molten metal from processing zone by mechanical method, i.e. relative motion of the billet and tool. Pulse arc discharges serve as the source of heat in processing zone. Electric contact processing by fusion is recommended for large-size parts of carbon and alloyed steels, cast iron, non-ferrous alloys, refractory and special alloys. It is not recommended for processing of TEM due to strong violation of TEM properties in the near-surface layers.

High-frequency electric spark processing is used for increasing the accuracy and reducing the roughness of surfaces processed by electric erosion method. The method is based on the use of low-power electric pulses at a frequency of 100 – 150 kHz.

Electric spark processing employs pulse spark discharges between electrodes, one of which is a billet being processed (anode), and the other is a wire tool (cathode). Thermoelectric material based on Bi_2Te_3 serves as a billet. The surface of the tool is destructed, so the wire must be constantly stretched. The range of used wire tool diameters is 0.03 mm – 0.1 mm. Brass, molybdenum and tungsten can serve as the wire material. The use of brass can result in the penetration of electroactive impurities into thermoelectric material. Repeated use of wire tool is not recommended, since it will cause uncontrolled variation of cut material parameters and frequent break of the wire. It is necessary to use liquids that cool electrodes and stabilize the process of cutting thermoelectric material ingots into discs (Fig. 2).

The disadvantages of this method include: relatively low processing throughput, electrode wire wear, the use of mostly relaxation (i.e. depending on the state of interelectrode gap) pulse-generating circuits of duration 10 – 200 μ s with the frequency of 2 to 5 kHz, the use of direct current polarity. On the processed surface of bismuth telluride-based thermoelectric material there appear near-surface damaged layers of depth 20 – 30 μ m which reduce the figure of merit of legs. Therefore, removal of damaged layer by chemical etching is a mandatory operation.

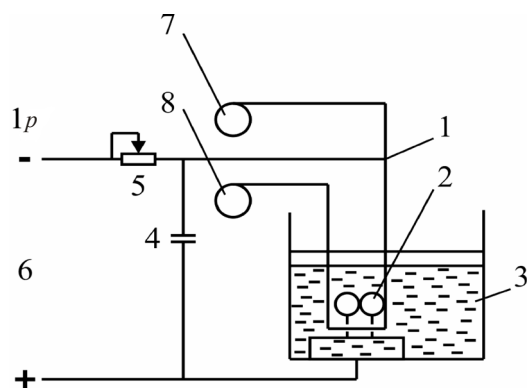

*Fig. 2. Schematic of electric spark processing of TEM:
1 – wire tool, 2 – ingots (TEM), 3 – discharge environment,
4 – capacitor, 5 – rheostat, 6 – supply source, 7 – wire coil,
8 – spent wire coil, 1p-electric spark processing mode.*

It should be kept in mind that electric erosion processing results in work space air contamination and, as a consequence, in environmental pollution, with harmful substances released in operation. Such substances are nitrogen dioxide, sulphur dioxide, carbon monoxide, and xylol.

Cutting by wires with bound abrasive

The method of cutting by wires with bound abrasive allows cutting Bi_2Te_3 ingots into discs, discs into legs of *n*- and *p*-types (Fig. 3).

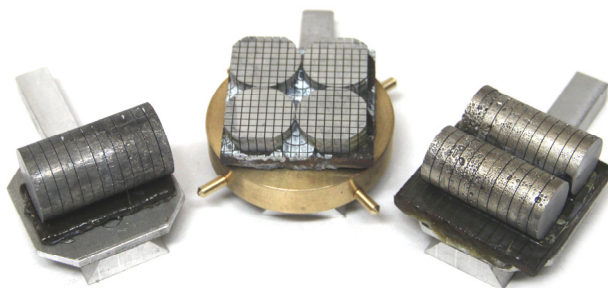
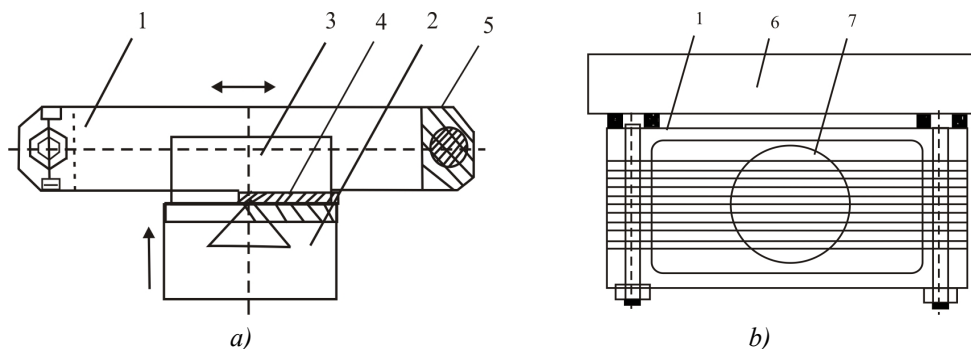

Fig. 3. Disks and branch of n-and p-type.

Cutting tool is based on a replaceable frame (Fig. 4) with a uniformly stretched diamond-coated wire. The winding pitch of tungsten wire is set by the grooves of spacer bars.



*Fig. 4. Replaceable frame coated with diamond grains: 1 – frame, 2 – table,
3 – TEM, 4 – gasket, 5 – spacer bars, 6 – carriage, 7 – wire coated with diamond grains.*

Cutting layer on the wire is formed by galvanic deposition of synthetic diamond grains of size 40/28. As a metal binder, nickel is used.

As compared to electric spark method, wire cutting yields cut discs and *n*- and *p*-type legs with much smaller structural damages on the surface of cut material. By virtue of low thermodynamic voltages that arise in destruction zone, the depth of damaged thermoelectric material layers does not exceed 10 – 25 μm .

Optimal cutting is 1 mm/min. A specially developed wire cutting machine Altec–13005M (Fig. 5) assures high throughput with a simultaneous use of 4 cutting tools.

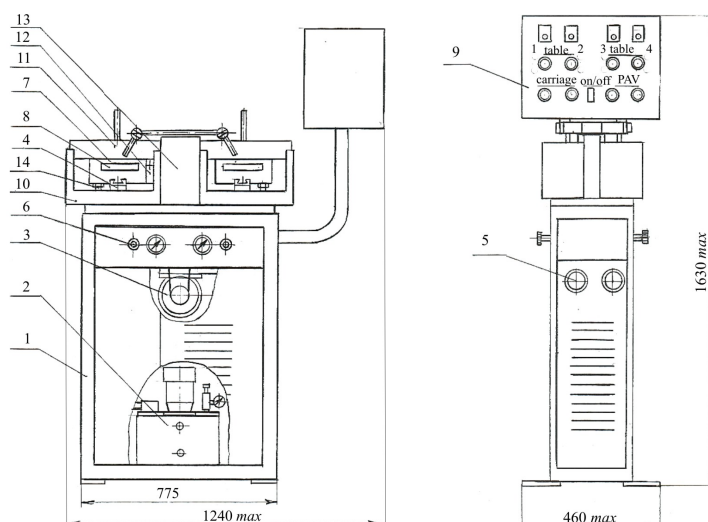

Fig. 5. Wire cutting machine Altec – 13005M.

- 1 – bed, 2 – hydro station, 3 – main drive, 4 – tables with hydraulic drives,
 5 – table lift-lowering servodrive motors, 6 – controllers of table delivery pressure,
 7 – carriage with hydrostatic guides, 8 – cutting frame with deposited diamonds,
 9 – control panel, 10 – tray, 11 – left lid, 12 – protective angle of left tray,
 13 – case, 14 – cutting depth microscrews.

During 8 hours of machine operation when cutting discs of *n*- and *p*-type thermoelectric material of diameter 24.0 mm and thickness 1.5 mm one can get at least 210000 half-elements of section $1.4 \times 1.4 \text{ mm}^2$.

Control cuts made it possible to determine waste ratio in the process of cutting thermoelectric material discs $\varnothing 24.00 \text{ mm}$ and thickness 1.5 mm into legs in powder form, and on washing and rejecting – in solid state.

Table

Size of legs	1.0×1.0×1.5 mm
Number of discs 1 pcs	weight 5 g.
Number of cuts	19
Yield ratio 283 pcs.	weight 3.02 g. 60.4%
Total amount of waste	weight 1.98 g. 39.6%
Solid waste	weight 0.34 g. 6.8%
Powder waste	weight 1.64 g. 32.8%
Size of legs	1.4×1.4×1.5 mm
Number of discs 1 pcs.	weight 5 g.
Number of cuts	14
Yield ratio 143 pcs.	weight 3.23 g. 64.6%
Total amount of waste	weight 1.77 g. 35.4%
Solid waste	weight 0.47 g. 9.4%
Powder waste	weight 1.3 g. 26%

Percentage-wise, powder waste is considerably greater than solid waste. On termination of 8 – hour work of wire cutting machine Altec – 13005M, powder waste settles in waste tank in the form of pulp. To facilitate further recovery, the waste of *n*- and *p*-type thermoelectric materials should be separated.

Machine Altec – 13005M allows separate collection of *n*- and *p*-type powder waste that appears at cutting of Bi_2Te_3 – based thermoelectric material.

Conclusions

1. The advantage of method for cutting by wire with bound abrasive as compared to electric erosion method with dimensionless processing of alloys based on bismuth telluride on wire cutting machines Altec-13005M is high throughput, minimal depth of damaged layer, lower electric energy consumption per unit of product, low cost of cutting process.

2. A method for separate collection of powder waste of *n*- and *p*-type Bi_2Te_3 – based thermoelectric material in cutting for subsequent recovery is described.

3. The use of wire cutting machine assures ecological safety of processing, as long as in operation (unlike electric spark method) no toxic vapors of semiconductor material volatile components get into environment.

References

1. Z.Yu.Hotra, *Handbook on the Technology of Microelectronic Devices* (Lviv: Kamenyar, 1986), 287p.
2. B.M. Goltsman, V.A. Kudinov, and I.A. Smirnov, *Semiconductor Thermoelectric Materials Based on Bi_2Te_3* (Moscow: Nauka, 1972), 320p.
3. Machine for Cutting of Semiconductor Materials Altec 13005 M. *Leaflet*.

Submitted 12.08.2015.