



УДК 624.012.45/46.006.06



**БАМБУРА А.М.**  
Д-р технічних наук, проф.,  
зав. відділу, ДП «Державний  
науково-дослідний інститут  
будівельних конструкцій»,  
м. Київ, Україна,  
e-mail: abambura@gmail.com,  
тел.: + 38 (050) 415-35-28,  
ORCID: 0000-0003-1402-3345



**ДОРОГОВА О.В.**  
Канд. технічних наук, ст.  
науковий співробітник,  
ДП «Державний науково-  
дослідний інститут будівельних  
конструкцій»,  
м. Київ, Україна,  
e-mail: dorogova@ukr.net,  
тел.: + 38 (044) 249-37-75,  
ORCID: 0000-0002-7838-6383



**САЗОНОВА І.Р.**  
Ст. науковий співробітник,  
ДП «Державний науково-  
дослідний інститут будівельних  
конструкцій»,  
м. Київ, Україна,  
e-mail: rostislavovna@gmail.com,  
тел.: + 38 (044) 249-38-88,  
ORCID: 0000-0002-8226-3589



**БОГДАН В.М.**  
Ст. науковий співробітник,  
ДП «Державний науково-  
дослідний інститут будівельних  
конструкцій»,  
м. Київ, Україна,  
e-mail: vasyi.bogdan@gmail.com,  
тел.: + 38 (044) 249-37-49,  
ORCID: 0000-0003-3371-3675

## РОЗРАХУНОК ПОЗАЦЕНТРОВО СТИСНУТИХ ГНУЧКИХ ЗАЛІЗОБЕТОННИХ ЕЛЕМЕНТІВ ЗА МЕТОДОМ «РЕАЛЬНОЇ» КРИВИЗНИ

### АНОТАЦІЯ

Метод визначення несучої здатності гнучких позацентрово стиснутих елементів із урахуванням ефектів другого порядку у розгорнутому вигляді чинними державними будівельними нормами України не представлено. За європейськими нормами для визначення несучої здатності гнучких залізобетонних елементів з урахуванням ефектів другого порядку застосовують метод номінальної кривизни. Він базується на використанні в розрахунках прогнозу кривизни (прогину) при досягненні граничних деформацій стиску бетону і деформації границі текучості арматури. Цей метод має цілий ряд недоліків. Перш за все, втрата несучої здатності гнучких елементів (втрата стійкості), як правило, відбувається при значно менших значеннях кривизни, ніж номінальна кривизна і, відповідно, критична сила буде значно більшою. По-друге, в Єврокодi для бетонів міцністю нижче класу C50/65 граничні деформації стиску бетону однакові і складають  $\varepsilon_{cu} = 350 \times 10^{-5}$ . Це означає, що номінальна кривизна не залежить від міцності бетону (при різному класі міцності бетону вона однакова), що суперечить фізичній природі явища. По-третє, для матеріалів, у яких діаграма роботи є криволінійною з низхідною гілкою, втрата стійкості може реалізуватись і для короткого

позацентрово стиснутого залізобетонного елемента (перерізу) та навіть для елемента, що згинається. Зазначені недоліки методу номінальної кривизни впливають на точність визначення критичної сили, а отже, і на надійність позацентрово стиснутих залізобетонних елементів та, відповідно, на надійність будівель у цілому. Результатом виконання даної роботи є розроблення методу розрахунку із визначення несучої здатності (критичної сили) гнучких позацентрово стиснутих залізобетонних елементів на основі використання деформаційного методу оцінки напружено-деформованого стану розрахункового перерізу, що базується на чітких фізично обґрунтованих передумовах.

**Висновок.** Аналіз результатів співставлення величини критичної сили, визначеної за методом реальної кривизни з показниками експериментальних досліджень гнучких залізобетонних колон при різних параметрах: міцності бетону, гнучкості, відсотка армування, початкового ексцентриситету, умов закріплення на опорах (усього для 66 колон) показав, що запропонований метод реальної кривизни достатньо точно відображає як якісно, так і кількісно процес, що моделюється.

**КЛЮЧОВІ СЛОВА:** залізобетонний позацентрово стиснутий елемент, деформаційний метод, гнучкість, розрахункова довжина, метод реальної кривизни.



## CALCULATIONS OF THE ECCENTRIC-COMPRESSED SLENDER REINFORCED CONCRETE MEMBERS APPLYING AN “EFFECTIVE” CURVATURE METHOD

**BAMBURA A.M.**, Dr., Prof., Head of department, State enterprise «The State Research Institute of Building Constructions»,  
e-mail: abambura@gmail.com,  
Kyiv, Ukraine,  
tel.: + 38 (050) 415-35-28,  
ORCID: 0000-0003-1402-3345.

**DOROGOVA O.V.**, PhD, Senior Scientist, Department of building and structures reliability, State enterprise «The State Research Institute of Building Constructions»,  
Kyiv, Ukraine,  
e-mail: dorogova@ukr.net,  
tel.: + 38 (044) 249-37-75,  
ORCID: 0000-0002-7838-6383

**SAZONOVA I.R.**, Senior Scientist, State enterprise «The State Research Institute of Building Constructions»,  
Kyiv, Ukraine,  
e-mail: rostislavovna@gmail.com,  
tel.: + 38 (044) 249-38-88,  
ORCID: 0000-0002-8226-3589

**BOGDAN V.M.**, Senior Scientist, State enterprise «The State Research Institute of Building Constructions»,  
Kyiv, Ukraine,  
e-mail: vasyi.bogdan@gmail.com,  
tel.: + 38 (044) 249-37-49,  
ORCID: 0000-0003-3371-3675

### ABSTRACT

The up-to-date construction norms of Ukraine do not provide a detailed method for determining the bearing capacity of the slender eccentric-compressed members considering of the second order effects. To determine the bearing capacity of the slender reinforced concrete members taking into account the second order effects in the European norms the method of nominal curvature is applied. The method is based on the calculations of the predicted curvature (deflection) under the ultimate compression deformations of the concrete and reinforcement yield deformation. This method has a number of imperfections. First of all, the loss of the bearing capacity of the slender members (buckling), as a rule, occurs at significantly lower values of curvature than the nominal curvature and, accordingly, the buckling force will be much greater. Secondly, in Eurocode for concrete strength less than class C50/65 the ultimate deformations of concrete compression are the same and equals to  $\varepsilon_{cu}=350\times 10^{-5}$ . This means that the nominal curvature does not depend on the concrete strength (for the different concrete classes of strength it is the same), contrary to the physics of the phenomenon. Thirdly, for materials, which have the curvilinear behavior diagram

with the drooping branch, the buckling can be realized also for a short eccentric-compressed reinforced concrete member (cross section) and even for a bending member. The mentioned imperfections of the nominal curvature method have influence on the accuracy of the buckling force determining and hence on the reliability of the eccentric-compressed reinforced concrete members and, accordingly, on the reliability of buildings in general. The result of this work is the development of an engineering method for calculating the bearing capacity (buckling force) of the slender eccentric-compressed reinforced concrete members applying a deformation method for the calculation of the stress-strain state of a design section, which is based on accurate physically grounded preconditions.

**Conclusion.** The results of the analysis of the comparison of the buckling force value, determined by the effective curvature method, with the data of experimental studies of the slender reinforced concrete columns under the different strengths of concrete, slenderness, percentage of reinforcement, initial eccentricity, support conditions (total of the 66 columns) showed that the proposed effective curvature method accurately represents both qualitatively and quantitatively the simulated process.

**KEY WORDS:** Reinforced concrete eccentric-compressed member, deformation method, slenderness, buckling length, effective curvature method.

### STATEMENT OF PROBLEM

The up-to-date construction norms of Ukraine DNB V.2.6-98:2009 [1] and DSTU B V.2.6-156:2010 [2] do not provide a detailed method of determining the bearing capacity of the slender eccentric-compressed elements considering of the second order effects. At the same time, EN 1992-1-1, Eurocode-2 [3] and DSTU-N B EN 1992-1-1 [4] proposed the method of nominal curvature to determine the bearing capacity of the slender reinforced concrete elements, taking into account the second order effects. The method of nominal curvature is based on applying in calculation a predicted curvature (deflection) under the ultimate compression deformations of the concrete and reinforcement yield deformation ( $\varepsilon_{cu}$  and  $\varepsilon_{s0}$ ). This method has a number of imperfections. First of all, the loss of the bearing capacity of the slender elements (buckling), as a rule, occurs at significantly lower values of curvature than the nominal curvature and, accordingly, the critical force will be much greater. Secondly, in [3,4] for concrete of strength less than class C50/65 the ultimate deformations of concrete under compression are the same and equals to  $\varepsilon_{cu}=350\times 10^{-5}$ . This means that the nominal curvature does not depend on the concrete strength (for the different concrete classes of strength, it is the same), contrary to the physics of the phenomenon. Thirdly, as it was have pointed in [5,6], for materials in which the behavior diagram is curvilinear with the drooping branch, like concrete, the buckling (unbalance between load and internal forces) can



be realized also for a short eccentric-compressed reinforced concrete element (cross section) and even for a bending element. The mentioned imperfections of the nominal curvature method have an influence on the accuracy of determining the buckling force, and on the reliability of the eccentric-compressed reinforced concrete members and, accordingly, on the reliability of buildings in general.

### RESEARCH OBJECTIVE

The purpose of the study is to develop an engineering approach concerning the determination of a bearing capacity (buckling force) of the slender eccentric-compressed reinforced concrete members based on accurate physically grounded preconditions and applying a deformation method for the calculation of the stress-strain state of a design section.

### BASIC MATERIAL

**Basis of columns (piers) design.** In the slender eccentric-compressed reinforced concrete members, which are under compression and bending (eccentric-compressed), the bending occurs. Increasing of bending causes a moment change (as a rule, its increase) into any cross-section along of a member, that equals to the product of the normal force by the deflection at this point. This leads to a decrease of bearing capacity of the slender compressed member in comparison with the value obtained from the calculation, without taking into account the effect of buckling. For the compressed reinforced concrete members, in most cases, the buckling effect is so small that it can be neglected in terms of practice. However, in some cases, when one has to deal with flexible members, for which the buckling not only has an effect, but is crucial for the value of their bearing capacity. Thus, a slender member is one, the bearing capacity of which significantly depends on the development of deflections along its length, and that should be taken into account during design.

The experimental-theoretical studies of the stability of slender compressed members began from the earliest period of structure mechanics development. Thus, Euler (1707-1783) obtained a solution of the problem of the stability of a centrally compressed idealized rod from an elastic material without limitation of its strength. Although, from a practical point of view, this solution is difficult to use in practice, since in nature there are no ideal centrally compressed rods from an ideally elastic material. However, this work

gave impetus to the development of a separate direction of structure mechanics. Real structures have geometric deviations, heterogeneity of materials by volume, and so on. In addition, another significant difference from the classical solution is that such material as concrete has a distinct nonlinear character of deformation, limited strength and deformability. Therefore, as a rule, the real structure calculating methods were developed on the basis of the appropriate experimental and theoretical studies.

At designing, first of all, it is necessary to consider which form of bending of the slender compressed member is realized in a real building or structure. It is accepted that there are two possible forms: the buckling of the building as a whole structure or the bend of a single column without buckling of the entire building (Fig. 1).

As can be seen from the figure, these types correspond to the different forms of the bending moment diagram. It should be borne in mind that if the frame of the whole building is buckled, all the columns of one floor will have the same shape of the moment's diagram. Taking into account the mentioned above, it is recommended to consider three basic steps at determining the bearing capacity of the slender compressed reinforced concrete members, subject to buckling:

- at the first stage, it is necessary to determine which forms of buckling mode are possible in the building under consideration;
- at the second stage it is checked whether the effect of buckling is significant and, accordingly, whether this structure should be considered as a slender;
- at the third stage, if the impact of buckling is significant, then it is necessary to perform calculations taking into account the buckling of the member.

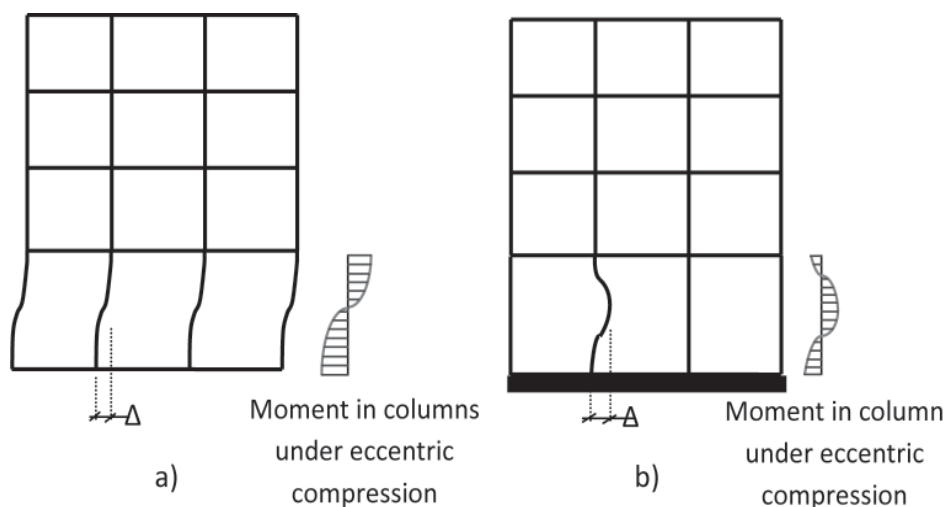

**Fig. 1** Types of the columns bending in the building structural design: a) buckling of the building frame; b) buckling of one column



According to the accepted classification of the structure systems, compressed members are divided into:

- members that are distorted and not distorted;
- rigid and slender.

The structures that do are not distorted refers to those, the bearing capacity of which does not depend significantly on the second order effects (buckling). The structures that are distorted refers to those, the bearing capacity of which depends significantly on the second order effects (Fig. 1, a).

If additional bending moments amount to more than 10% of the first order moments, this is considered to be a significant effect of displacement on the member's bearing capacity. In practice, it is very difficult to determine whether this structure is distorted or not distorted, and it depends on the structural system resistance (rigidity) to horizontal displacement. The presence in the structure system of the distorted members negatively affects on the building resistance under seismic impacts. Therefore, in practice, to provide the building's seismic resistance, designers, by means of constructive measures, try to significantly reduce the displacement effect by arranging "rigid core" or (and) longitudinal and transverse wall elements, diaphragms, bracing. In fact the "rigid" structure diagram is realized. The presence in the building of "rigid core", bracing and walls, which prevent significant displacement, is considered as a system that is not distorted and excludes the requirement for further control of the displacement of the entire structural system.

In case of establishing that in the structural system there are no distorted members and the influence of the second order effects is insignificant, only the local deformation of individual columns (Fig. 1, b) should be considered.

Otherwise, when we deal with a structural system, in which there are members that are distorted, we have to consider two sub-cases:

- the structural system consists of rigid members. The rigid structures may be accepted as non-distorted, except circumstances when the rigidity members are relatively slender. In such case, the rigidity members should be analyzed for the possibility of displacement. But, if we accounting the deformation of the rigidity members inside the structural system (Fig. 1,a), then it is possible to neglect the displacement effect;
- the structural system consists of slender members. Such structures, at first, have

to be checked for their ability to bear the displacement of the whole system (Fig. 1,a) and then each column in diagram should be checked for its resistance to deformation ( Fig. 1,b).

After completing the first stage analysis, at the second stage it is necessary to perform a check on the impact of buckling on the column bearing capacity - whether it is significant, or it can be neglected. It is assumed that the effect of buckling is significant when it increases the first order moment more than by 10%. However, in practice, this limit is difficult to use, because it is necessary to perform the complete calculation of the structure. Therefore, in Eurocode-2 and in DBN B.2.6-98 the simplified rules, which allow determining without complicated calculations whether the specified limit is reached, are proposed. These rules are formulated in two parameters:

- column buckling length;
- slenderness ratio.

**The definition "buckling length"** is used in almost all cases, for which it is necessary to take into account the effects of buckling. The buckling length is the length of an equivalent compressed pin-ended member, which has the same resistance to the buckling failure as the designed member (Fig. 2).

An equivalent compressed member has the same characteristics of the normal cross-section and materials as the considered member. The value of the buckling length of the compressed member depends on the bending type of and the fixing conditions at the ends. The buckling length of the member, which does not have a distortion, is 0.5...1.0 of its actual length. The buckling length of the members, which are distorted and unfixed, can be larger up to two times than their actual length. Mathematically, the buckling length is a function of the rigidity of a column and the members adjacent to each of its ends.

According to DSTU B. V.2.6-156 [2], in the general case the dependences for determining the buckling

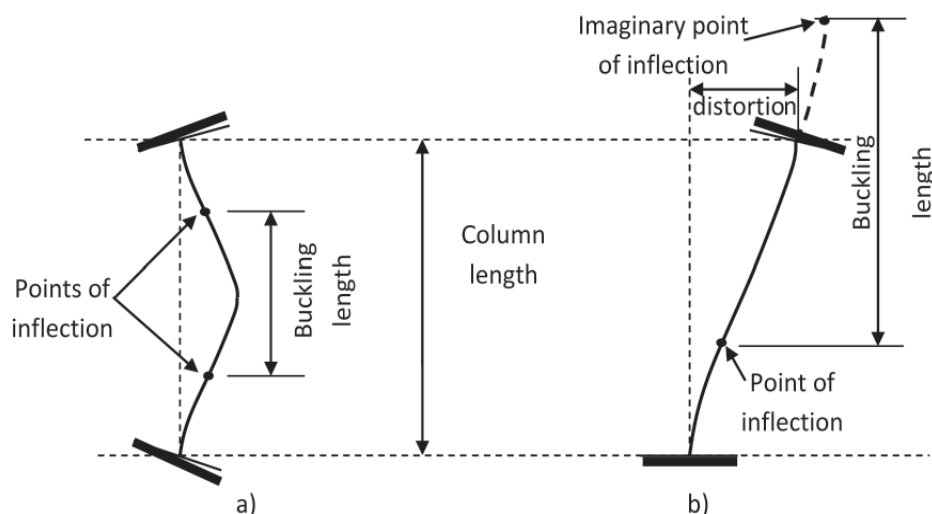

**Fig. 2** Concept of buckling length:  
a) isolated column; b) column in case of frame displacement



length  $l_0$  of the compressed members of reinforced concrete frames are in the following view.

For fixed members (columns of the rigid frames) Fig. 3f

$$l_0 = 0,5l \sqrt{\left(1 + \frac{k_1}{0,45 + k_1}\right) \cdot \left(1 + \frac{k_2}{0,45 + k_2}\right)}. \quad (1)$$

For unfixed members (see Fig. 3g):

$l_0 = l \times$  large of two quantities:

$$a = \sqrt{\left(1 + 10 \frac{k_1 \cdot k_2}{k_1 + k_2}\right)}; \quad (2)$$

$$b = \left(1 + \frac{k_1}{1 + k_1}\right) \cdot \left(1 + \frac{k_2}{1 + k_2}\right), \quad (3)$$

where:  $l_0$  is a buckling length of column;  $k_1$  and  $k_2$  are respectively relative angular rigidities of the supporting fixings;  $k = (\theta / M) \cdot (EI / l)$ ;  $\theta$  is an angle of rotation in fixing of the column ends from bending moment;  $M$  is the moment that occurs in fixing under buckling failure;  $l$  is the length of the compressed member in cleanliness between the end's fixing;  $EI$  is the initial bending rigidity of the compressed members which are checked for stability.

If, above the upper end of the considered column or below its bottom end there is a compressed member, it is necessary to determine whether this column increases the value of the deflection, or, conversely, limits it. When determining  $k$ , if the fixing of the ends increases the deflection, then the angle of rotation under buckling  $(EI / l)$ , should be replaced by  $[(EI / l)_a + (EI / l)_b]$ , where  $a$  and  $b$  are respectively representing a compressed member (column) above and below the node. If the column influence limits deflection, then in calculation a rigidity factor  $\theta / M$  can be included. It is logical to assume that the probability of simultaneous influence on increasing of the column deflection the above and below the connections is rather low. Although, in the column a deflection will be developed, but it has to be much less than in the column under buckling failure.

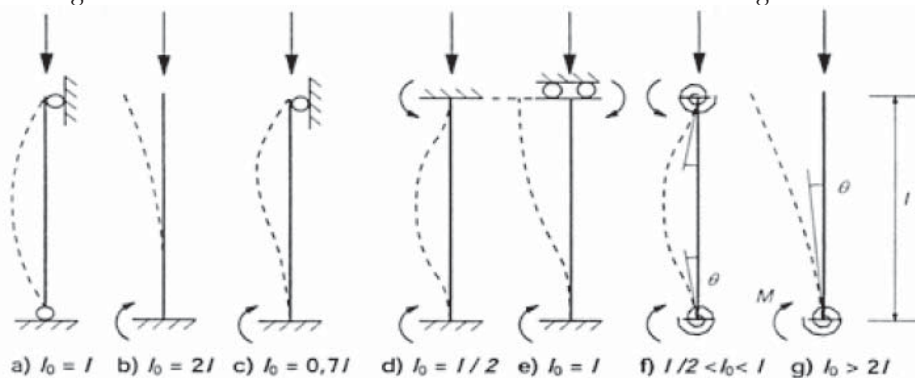

Fig. 3 Examples of different forms of stability loss and corresponding buckling lengths of isolated members

At that, the rigidity of the fixed members should considering the effect of nonlinear concrete behavior when determining the buckling length.

Taking into account the above mentioned, the length of the real column with behavior in the structural system according to the diagram 3 c (Fig. 3), will be  $0,77 l$ , and according to the diagram 3 d –  $0,59 l$ .

For some design diagrams of column fixing the reduced length was theoretically obtained for the particular members of constant cross-section (Fig. 3).

The second factor that effectively influences on the column stability under buckling is its slenderness ratio, which is defined as:

$$\lambda = l_0 / i, \quad (4)$$

where:  $l_0$  is buckling length;  $i$  is radius of gyration of a concrete cross-section without cracks.

The radius of gyration of a concrete cross-section is determined from relation:

$$i = \sqrt{I / A_c}, \quad (5)$$

where:  $I$  is the second moment of the cross-section area;  $A_c$  is the cross-section area. For a rectangular cross-section  $I = bh^3/12$ ;  $A = bh$ , respectively, the radius of gyration  $i = 0,2887h$ , where  $h$  is the depth of the cross-section of the column on the axis, which is perpendicular to the axis of the bending. The circular section radius of gyration is equal to its actual radius.

In the old SU building code (SNiP), the ratio of the column buckling length to the corresponding depth of the cross-section was taken as the slenderness ratio. Such an approach rather corresponds to the physical nature of reinforced concrete members. This is due to the fact that we have to deal not with the classic (idealized) cases of buckling, but with the fact that concrete and reinforce have pronounced nonlinear properties. But the use of the inertia radius has some advantages, since it is more universal and provides possibility to design columns not only with a rectangular cross section.

To complete the second stage of the compressed reinforced concrete columns analysis it is necessary to determine whether ones has to take into account the buckling influence on their bearing capacity. There

are software complexes that with sufficient accuracy solve such problems for complex reinforced concrete systems taking into account geometric and physical nonlinearity. The building codes provide a simplified method for evaluating the need to take into account the buckling influence.

Thus, the buckling influences can be neglected if the column slenderness  $\lambda$  is less than a certain value (limiting)  $\lambda_{lim}$ .



It is recommended to determine the value of  $\lambda_{lim}$  by the relation:

$$l_{lim} = 20 \cdot A \cdot B \cdot C / \sqrt{n}, \quad (6)$$

where:  $A = 1/(1+0,2\varphi_{ef})$ , here  $\varphi_{ef} = \varphi_{(\infty, t_0)} \frac{M_{0Eqp}}{M_{0Ed}}$ , is

reduced creep coefficient (if coefficient  $\varphi_{ef}$  is unknown, one can take it  $A = 0.7$ ). It is not difficult to show that when changing  $M_{0Eqp}/M_{0Ed}$  from 0.4 to 0.9 for medium-strength concrete (class C20/25 ... C35/40) factor  $A$  has value from 0.57 to 0.85. Therefore, in Eurocode-2 it is recommended to take  $A = 0.7$  and  $B = \sqrt{1+2\omega}$ , where  $\omega = A_s f_{yd} / A_c f_{cd}$ . As a rule, the purpose of calculations is to determine the value  $A_s$ , then it is unlikely that the value of  $B$  will be known, but it is possible to estimate the value of  $\omega$  as for the first order effects applying calculations by the deformation method. If the coefficient  $\omega$  is unknown, it is allowed to use  $B = 1.1$  and  $C = 1.7 - r_m$ , where  $r_m = M_{01}/M_{02}$  is the ratio of moments.  $M_{01}$  and  $M_{02}$  are the moments of the first and second order effects on fixed ends, at that  $|M_{01}| \geq |M_{02}|$ . Thus, for a usual case, with the column under bending with two moments,  $C$  always will be more than 1.7.

If the moments  $M_{01}$  and  $M_{02}$  at the fixed ends give tension on one side, it is necessary to take  $r_m$  positive (i.e.  $C \leq 1.7$ ), otherwise,  $r_m$  is negative (i.e.  $C > 1.7$ ). The value of  $r_m$  should be taken equal to 1.0 (i.e.  $C = 1.7$ ) in the following cases:

- in the fixed members, in which the first order moments occurs only/or mainly from imperfections or transverse loadings;
- for at all unfixed members.

$\omega = A_s f_{yd} / A_c f_{cd}$  is a reinforcement coefficient;  $A_s$  is the total reinforcement area of a cross-section;  $A_c$  is the total area of a concrete cross-section;  $n = N_{Ed} / A_c f_{cd}$  is a relative axial force;  $M_{0Eqp}$  is the moment taking into account the first order effect at practically constant combination of loads (limit state of the second group);  $M_{0Ed}$  is the moment taking into account the first order effect at design combination of loads (limit state of the first group).

Thus, using the recommended above values of the factors in relation (6), the minimum value  $\lambda_{lim}$  for a column that bends under two moments, can be  $27 / \sqrt{n}$ .

For cases of biaxial bending, the buckling criterion can be checked separately for each direction. Depending on the results of these checks, the impacts of the second order effects: a) may not be taken into account for both directions; b) must be taken into account in one direction or c) must be taken into account in both directions.

### CALCULATION OF THE COMPRESSED MEMBERS TAKING INTO CONSIDERATION BUCKLING

If the preliminary analysis showed that the further design of the compressed members should be performed taking into account buckling (the members are slender), then the designer has to perform the

structure calculation taking into account the second order effect.

Unfortunately, the national building codes of Ukraine do not includes the necessary practical recommendations for calculations of the compressed members taking into account buckling. Since the basic principles are taken in EN 1992-1-1, to ensure them it is also possible to use the relevant recommendations which are given in the manual [7].

So, in the given manual [7] it is recommended to apply one of the 4 main approaches:

1. The general method, which is based on the nonlinear calculation of the structure, taking into account both physical and geometric nonlinearity. Of course, such an approach requires applying of complex software. Therefore, the manual does not consider it.

2. Calculation taking into account buckling, which is based on the nominal rigidity of a member or structure. This method requires less complex software than the previous one, but for it the detailed information concerning the reinforcement of the member is also necessary.

3. Method with applying the moment increase factor. According to this method, the calculated moment which includes also second order effects, is determined by multiplying the first order moment by the determined factor.

4. The method of nominal curvature. According to this method, the limiting value of the deflection is determined, and the second order moment, which is calculated at ultimate deflection, is added to the first order moment.

The analysis of the considered simplified methods (2-4) was showed that each of them has both positive and negative properties those influencing on the accuracy of the buckling force determination. Therefore, applying the deformation method [1,2], the best results of the calculation can be obtained by the proposed so-called effective curvature method.

In the classical theory when determining buckling failure, as a rule, deformation of the slender pin-ended member is considered. Such diagram of the member fastening does not correspond to the real conditions of the column in the building. As a rule, a column in a frame is monolithically joined with other members (floors, columns from below and from above) from above and from below and accordingly is subjected to their influence. The column in a general case is schematically shown in Fig. 4.

As one can see from the figure, a part of the column can be considered as a hinged on the ends, similar to that for which there are methods of calculation. The distance between points of inflection is taken at the buckling length  $l_0$ . The maximum moment caused by the buckling effect will be in the middle of the buckling length of the column and, as a rule, is close to the middle of the length of the real column. Therefore, the moment in a critical cross-section includes the maximum first order moment and the moment caused

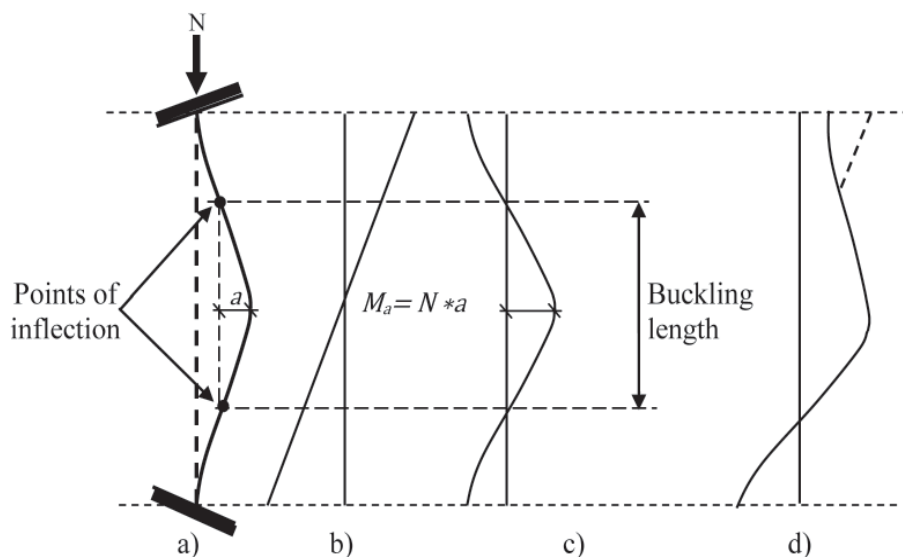

**Fig. 4** Moments and deformations of a single column in a rigid frame: a) bent shape; b) first order moments; c) bending moment caused by deflection; d) moment's diagram

by random influences. In the case of different values of the moments at the column ends, the manual [7], recommends to estimate the moment in the critical section by relation (7):

$$M_{0e} = 0,6M_{max} + 0,4M_{min}, \quad (7)$$

where:  $M_{max}$  and  $M_{min}$ , are, accordingly, maximum and minimum moments at the column supports. Moreover, the relation (7) is valid if the moment  $M_{0e}$  is not less than  $0,4 M_{max}$ .

In all calculation methods, mentioned above, it is necessary to take into account the possibility that the structure may have the occasional vertical deviations.

The requirements for taking into account the influence of geometric imperfections are given in 6.1 of DSTU B V.2.6-156.

For particular members, the influence of imperfections can be taken into account in two alternative ways, a) or b):

a) – as a certain eccentricity in the middle of the column, expressed through:

$$e_i = \theta_i \cdot l_0 / 2, \quad (8)$$

where:  $l_0$  – buckling length of the column.

b) – for particular slender columns, fixed by the system of braces, for the purpose of simplification it is recommended to take bigger between values  $e_0 = l_0/400$ ,  $e_0 = h/30$  or  $e_0 = 10$  mm. Accordingly, the moment from random eccentricity influence will be:

$$M_0 = N_{Ed} \times e_0, \quad (9)$$

So, as the moment  $M_i$  from random eccentricity has the maximum value in the middle of the column length, it should be added not to  $M_{max}$  and/or  $M_{min}$ , but to  $M_{0e}$ . Thus:

$$M_{tot(l)} = M_{0e} + M_i. \quad (10)$$

### CREEP INFLUENCE CONSIDERING

Usually, calculating the bearing capacity of reinforced concrete members, the effects of concrete creep, as a rule, are not taken into account. At the same time, as is shown by experimental studies, the effects of creep have a significant impact on the bearing capacity of the slender columns. A decrease of their bearing capacity can reach up to 30%. Consequently, there is an urgent necessity to take into account the creep effects when calculating of the slender reinforced concrete members.

The duration of the load can be taken into account simplified, using the reduced creep coefficient  $\varphi_{ef}$ , which, being applied with design load, gives a creep deformation (additional curvature), corresponding to the main combination of loads:

$$\varphi_{ef} = \varphi(\infty, t_0) \cdot M_{0Eqp} / M_{0Ed}, \quad (11)$$

where:  $\varphi(\infty, t_0)$  – is ultimate creep coefficient (see section 3);  $M_{0Eqp}$  – is the first order moment under quasi-constant loads (second group);  $M_{0Ed}$  – is the first order moment under design load combination (first group).

The curvature of the critical cross-section of the slender reinforced concrete members may increase due to the development of the concrete creep deformations. It is recommended to taken into account this effect multiplying the curvature value by factor  $k_\varphi$ :

$$k_\varphi = 1 + (0,35 + \frac{f_{ck}}{200} - \lambda / 150) \varphi_{ef}. \quad (12)$$

### CALCULATION OF THE SLENDER MEMBERS' DEFLECTION

The slender members' deflection can be determined if we assume that the distribution of the deflection along the column length is described by a sinusoid. Assuming that the curvature is proportional to the moment, that equal to the value of the deflection multiplied by the magnitude of the axial force, one can obtain the following dependence:

$$a = \iint \left( \frac{1}{r} \right) \sin \left( \frac{\pi x}{l} \right) dx. \quad (13)$$

In the middle of the column ( $x/l_0 = 0.5$ ) a deflection, which in EN 1992-1-1 for convenience is denoted as



eccentricity, approximately will be:

$$a = e_2 = 0,1l_0^2 \left( \frac{1}{r} \right), \quad (14)$$

where  $e_2$  is the second order eccentricity;  $1/r$  or  $\aleph$  is a curvature in cross-section.

Thus, the total eccentricity of force applying in the designed cross-section is:

$$e = e_0 + e_{0e} + e_2. \quad (15)$$

If necessary, one can determine the designed moment in the middle of the column:

$$M_{Ed} = M_{0Ed} + M_2,$$

where:  $M_2 = N_{Ed} \times e_2$ .

It should be kept in mind that with the development of the deflection, both the moment in the middle of the column and moments at the ends fixing are changed. As a rule, the numerically smaller moment in fixings increases, and the larger one decreases. Such moments' redistribution is possible if the reinforced concrete cross-section can bear it without failure.

#### EFFECTIVE CURVATURE METHOD

The method of nominal curvature does not entirely reflect the nature of the considered complex physical phenomenon, since the buckling failure of a slender compressed member occurs, as a rule, much earlier than the value of nominal curvature is reached. The above indicated can occurred lead to significant errors in the critical force determination and not in the margin of bearing capacity. As shown in works [5,6], when the real curvilinear diagrams of concrete deformation are applied, both bending and short eccentric-compressed reinforced concrete members may lose their stability (disturbance of equilibrium between internal forces and external load). In national building codes of Ukraine [1,2] this is the so-called "extreme criterion of bearing capacity loss". Therefore, an improved method for determining the bearing capacity of slender reinforced concrete members applying not the nominal (ultimate) but effective curvature - the effective curvature method is proposed. The nominal curvature, as a rule, can be realized at buckling failure in the columns with slenderness close to the ultimate one.

**Effective curvature method** allows to determining the buckling forces in slender members more precisely. Moreover, the elementary programs in the Excel environment can be used for calculations. This method can be used not only for of rectangular, but also for circular and I-shaped cross-sections, as well as pre-stressed slender reinforced concrete members.

The basic principles of the effective curvature method are as follows.

After the initial analysis of the compressed members deformed state in the building frame, and determination the buckling length  $l_0$  and the

slenderness  $\lambda_{lim}$ , a comparison of real slenderness with the ultimate one is performed. In the case of  $\lambda > \lambda_{lim}$  it is necessary to perform calculations of the compressed member taking into account the influence of buckling.

A block of necessary output data is formed including the geometrical parameters of the column and its cross-section, values of normal force ( $N_{Ed}$ ) and the column moments at the ends ( $M_{01}$  and  $M_{02}$ ), physical and mechanical characteristics of concrete and reinforcement, reinforcement area and ultimate creep factor  $\varphi(\infty, t_0)$ . The moments at the column ends can be determined from the calculation of the static diagram of the frame system. Since the effective curvature method assumes the presence of an reinforcement area of a reinforced concrete column cross-section, it can be set in two approaches.

By the first one, the reinforcement for the cross-section of a short column is determined by an iterative way using the sum of eccentricities, random and from the first-order effects ( $e_{tot(0)} = e_{0e} + e_0$ ), where  $e_0$  is a random eccentricity. It should be noted that, engineering experience of the slender eccentric-compressed members calculating shows, that it is recommended to take bigger between values  $e_0 = l_0/400$ ,  $e_0 = h/30$  or  $e_0 = 10 \text{ mm}$  as a random eccentricity. The calculations are performed in the sequence shown below. In the case where the deformations of the reinforcement in the tension region are less than a value  $\varepsilon_{s0} = -f_{yd} / E_s$ , it is necessary to increase the reinforcement.

By the second one, the average factor of reinforcement, approximating to 2% of the cross-section area we is assigned, and calculations in the given below sequence are performed. If it is necessary due to the calculation results, the reinforcement changes and the calculations are repeated until the difference between the calculation result and the  $N_{Ed}$  will be within  $\pm 5\%$ .

In the presence of all necessary initial data, calculations are performed in the following sequence:

1. According to the relation (1), the design length of the column is determined.
2. By relation (4), the column slenderness coefficient is determined.
3. The ultimate slenderness is determined by relation (6).
4. Evaluation of the necessity of taking into account the second order effects in calculation is performed by the inequation  $\lambda \geq \lambda_{min}$ . If result of solving is positive, it is necessary to perform calculations considering buckling.
5. By relation (12), the coefficient  $K_\varphi$  of creep influence on the critical force is determined.
6. The greater of two eccentricities from the influence of the support moments in the middle of the column is determined:

$$e_{0e} = 0,6 \cdot e_{0e2} + 0,4 \cdot e_{0e1}, \quad e_{0e} = 0,4 \cdot e_{0e2},$$

where:  $e_{0e1} = M_{01} / N_{Ed}$ ,  $e_{0e2} = M_{02} / N_{Ed}$ .





7. The greater of random eccentricity values  $e_0 = l_0/400$ ,  $e_0 = h/30$  or  $e_0 = 10 \text{ mm}$  is determined for slender columns.
8. The second-order eccentricity at an  $i$ -step of the calculation taking into account the creep influence is determined by relation:  $e_{2(i)} = 0,1K_\varphi l_0^2 \aleph_{i-1}$ . The second order eccentricity is determined at each step by  $\varepsilon_{c(i)}$ . The curvature  $\aleph_i$  is determined in the process of a system of nonlinear equilibrium equations solving by the algorithm given in [2].
9. The total eccentricity (random, first order and second order) is determined at each step of the calculation:  $e_{tot(i)} = e_{0e} + e_0 + e_{2(i)}$ .
10. The change in the total eccentricity at each step of the calculation is recommended to be performed in the following way. In the first calculation step, at  $\varepsilon_{c(i)} = 0,1\varepsilon_{cu}$ , the value of  $\aleph_i$  is determined for the sum of eccentricities - random  $e_0$  and from the first order influence  $e_{0e}$ . The second order eccentricity  $e_{2(1)}$ , and the total eccentricity  $e_{tot(1)}$  are determined. With eccentricity  $e_{tot(1)}$  the calculations are performed on the second step for  $\varepsilon_{c(i)} = 0,2\varepsilon_{cu}$ . By the obtained on the first step value  $\aleph_i$ , one determines the second order eccentricity  $e_{2(2)}$  and the total eccentricity  $e_{tot(2)}$ . By the eccentricity  $e_{tot(2)}$ , one determines the curvature at the third step of the calculations and so on until the deformation of the compressed concrete of the value  $\varepsilon_{cu}$  is reached.
11. Analyzing the table of calculation results, one determines the buckling force (the maximum value of normal force). A comparison of the calculated buckling force with the external  $N_{Ed}$  should be done and, if the difference between comparison values is within  $\pm 5\%$ , one can assume that the required precision of the solution has been achieved. If the specified condition is not satisfied, it is necessary to increase or decrease the reinforcement and perform calculations according to items 7...10. In case of the necessity to obtain more proper results, it is recommended to fulfill several iterations for clarifying the reinforcement.

#### AN EXAMPLE OF DETERMINING THE BUCKLING FORCE BY THE EFFECTIVE CURVATURE METHOD

It is given: concrete column length is 9.6 m, cross-

section is  $300 \times 300 \text{ mm}$  (Fig. 5). Class of concrete strength is C30/35 ( $f_{ck} = 22,5 \text{ MPa}$ ;  $f_{cd} = 19,5 \text{ MPa}$ ;  $\varepsilon_{c1,ck} = 0,00181$ ;  $\varepsilon_{c1,cd} = 0,00172$ ;  $\varepsilon_{cul,ck} = 0,00325$ ;  $\varepsilon_{cul,cd} = 0,0031$ ). Column reinforcements are 4  $\text{Ø}28 \text{ A500C}$  of total area  $A_s = 24,63 \text{ cm}^2$ ;  $f_{yk} = 500 \text{ MPa}$ ;  $f_{yd} = 416,6 \text{ MPa}$ . Ultimate creep coefficient is  $\varphi(\infty, t_0) = 2,3$ .  $N_{Ed} = 1500 \text{ kN}$ ;  $M_{01} = 40 \text{ kN}\cdot\text{m}$ ;  $M_{02} = 80 \text{ kN}\cdot\text{m}$ . Ratio  $M_{0Egp}/M_{0Ed} = 0,75$ . The column is situated into a rigid frame.

#### CALCULATION

1. By relation (1) at  $k_1 = k_2 = 0,1$  (see. Note to 6.2.2.2.3 [2]) compute the column buckling length:

$$l_0 = 0,5l \sqrt{\left(1 + \frac{k_1}{0,45 + k_1}\right) \cdot \left(1 + \frac{k_2}{0,45 + k_2}\right)} = 0,5 \cdot 9,6 \sqrt{\left(1 + \frac{0,1}{0,45 + 0,1}\right) \cdot \left(1 + \frac{0,1}{0,45 + 0,1}\right)} = 0,59l = 5,67 \text{ m}.$$

2. Column slenderness is

$$\lambda = \frac{l_0}{i} = \frac{5,67}{0,2887 \times 0,3} = 65,5.$$

3. Calculate the ultimate slenderness by relation (6):

$$\lambda_{min} = \frac{20ABC}{\sqrt{n}} = \frac{20 \cdot 0,7435 \cdot 1,59 \cdot 2,2}{\sqrt{0,855}} = 52,1,$$

where:

$$A = 1/(1 + 0,2\varphi_{ef}) = 1/(1 + 0,2 \cdot 1,725) = 0,7435,$$

$$\text{where } \varphi_{ef} = \varphi(\infty, t_0) \cdot M_{0Egp}/M_{0Ed} = 2,3 \cdot 0,75 = 1,725;$$

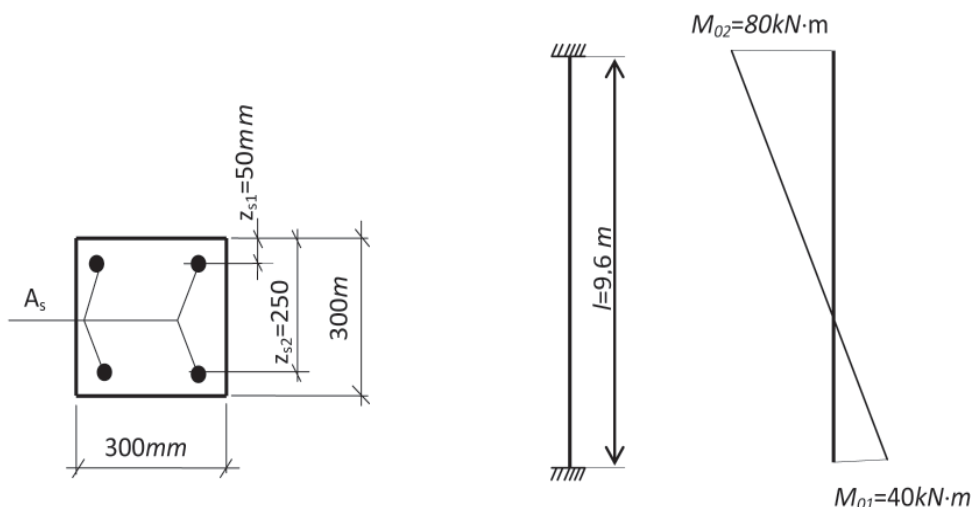

Fig. 5 Geometric parameters of column for calculation



$$B = \sqrt{1 + 2\omega} = \sqrt{1 + 2 \cdot 0,585} = 1,47,$$

where

$$\omega = A_s f_{yd} / A_c f_{cd} = 0,002463 \cdot 416,6 / 0,3 \cdot 0,3 \cdot 19,5 = 0,585;$$

$$C = 1,7 - r_m = 1,7 + 0,5 = 2,2,$$

$$\text{there } r_m = M_{01} / M_{02} = -0,4 / 0,8 = -0,5;$$

$$n = N_{Ed} / A_c f_{cd} = 1,5 / 0,3 \cdot 0,3 \cdot 19,5 = 0,855.$$

The column slenderness is more than the ultimate one  $65,5 > 52,1$ . Thus, the column is slender and it is necessary to calculate the second order effects.

- Determine the eccentricity in the middle of the column from the support moments

$$e_{0e1} = -40 / 1500 = -0,0267 \text{ m};$$

$$e_{0e2} = 80 / 1500 = 0,0533 \text{ m};$$

$$e_{0e} = \max \begin{cases} = 0,6 \times e_{0e2} + 0,4 \times e_{0e1} = 0,6 \times 0,0533 + 0,4(-0,0267) = 0,0213 \text{ m} \\ = 0,4 \times e_{0e2} = 0,4 \times 0,0533 = 0,0213 \text{ m} \end{cases}$$

obtained  $e_{0e} = 0,0213 \text{ m}$ .

- Determine the random eccentricity for slender column greater from  $e_{\theta} = l_0 / 400 = 5,67 / 400 = 0,0142 \text{ m}$ ,  $e_{\theta} = h / 30 \text{ m}$ ,  $e_{\theta} = 10,0 \text{ mm}$ ,

obtained  $e_{\theta} = 0,0142 \text{ m}$ .

- Determine the second-order eccentricity taking into account the effect of creep:

$$e_2 = 0,1(1/r)K_{\varphi} l_0^2 = 0,1 l_0^2 K_{\varphi} \aleph = 0,1 \cdot 5,67^2 \cdot 1,07 \cdot \aleph = 3,44 \aleph,$$

where:

$$K_{\varphi} = 1 + \beta \cdot \psi_{ef} = 1 + 0,0408 \cdot 1,725 = 1,07;$$

$$\beta = 0,35 + f_{ck} / 200 - \lambda / 150 = 0,35 + 25,5 / 200 - 65,5 / 150 = 0,0408.$$

The curvature  $\aleph$  is determined in the process of solving the system of nonlinear equilibrium equations by the deformation method. The solution algorithm is similar to the one given in [2]. The difference lies in the eccentricity value in the middle of the column at each calculation stage:

$$e_{tot} = e_{0e} + e_{\theta} + e_2 = 0,0213 + 0,0142 + 3,44 \aleph = 0,0355 + 3,44 \aleph.$$

Performing the calculations by the algorithm given in [2] with taking into account the deflection (eccentricity  $e_2$ ) at each step by  $\varepsilon_{c(1)}$ , we obtain a complete curve of the cross-section state up to concrete destruction.

As can be seen from the table, the bearing capacity (buckling force) of a slender column, taking into account the second order effects, reaches a value of 1605 kN, which is more than designed forces  $N_{Ed} = 1500 \text{ kN}$  by only 6,5%. Thus, the sufficient accuracy of the calculation is provided. In Fig. 6 the full curve of the cross-section state for a slender column is shown. For comparison, the same figure shows the curve of the cross-section state of a short column, taking into account the maximum value of  $e_{tot}$ . As can be seen from the figure, formally, at given output data, the buckling failure occurs in both short and slender columns. Moreover, the buckling failure of both short and slender columns occurs considerably earlier than the nominal curvature is achieved. As expected, the bearing capacity (load at buckling) of the slender column is appreciably lower than the bearing capacity of a short column (cross-section).

Table 1

Point number	$e_{tot(i)} = 0,0355 + 3,44 \aleph_{(i-1)}$ m	$\varepsilon_{(1)}^{(i)}$	$\varepsilon_{(2)}^{(i)}$	$\aleph$	$x_1, \text{ m}$	$\sigma_{s1}, \text{ MPa}$	$\sigma_{s2}, \text{ MPa}$	$N, \text{ MN}$
1	0,0355	0.00031	0.0000527	<b>0.000858</b>	0.361446	53.423	19.116	0.494
2	0,0355 + 3,44 · <b>0.000858</b> = 0,03845	0.00062	0.00006975	0.001834	0.338028	105.65	32.291	0.872
3	0.041809	0.00093	0.00005022	0.002933	0.317125	156.67	39.37	1.149
4	0.045588	0.00124	-0.00000062	0.004135	0.29985	206.64	41.23	1.345
5	0.049725	0.00155	-0.00008246	0.005442	0.284846	255.58	37.923	1.476
6	0.054219	0.00186	-0.00020057	0.006869	0.270799	303.31	28.571	1.555
7	0.059127	0.00217	-0.00035464	0.008415	0.257859	349.84	13.226	1.595
8	0.064449	0.00248	-0.0005425	0.010075	0.246154	395.25	-7.75	1.605
9	0.070157	0.00279	-0.0007719	0.011873	0.234987	416.6	-35.65	1.560
10	0.07634	0.0031	-0.0010323	0.013774	0.225056	416.6	-68.72	1.473

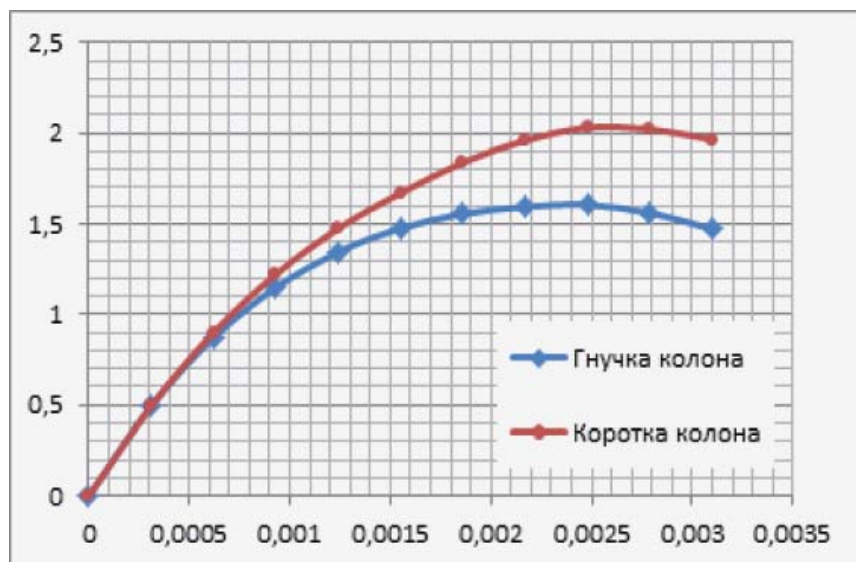

Fig. 6 The complete diagram of short and slender columns

### CONCLUSIONS

The results of the analysis of the comparison of the buckling force value, determined by the effective curvature method, with the data of experimental studies of the slender reinforced concrete columns under the different strengths of concrete, slenderness, percentage of reinforcement, initial eccentricity, support conditions (total of the 66 columns) showed that the proposed effective curvature method accurately represents both qualitatively and quantitatively the simulated process.

### БІБЛІОГРАФІЧНИЙ СПИСОК

1. Бетонні та залізобетонні конструкції. Основні положення: ДБН В.2.6-98:2009. - [Чинні від 2011-06-01]. - Київ: ДП "Укрархбудінформ", 2011. - 97 с. - (Держ. буд. норми України).
2. Конструкції будинків і споруд. Бетонні та залізобетонні конструкції з важкого бетону. Правила проектування: ДСТУ Б В.2.6-156:2010. - [Чинний від 2011-06-01]. - Київ: ДП "Укрархбудінформ", 2011. - 118 с. - (Нац. стандарт України).
3. EN 1992-1-1:2004, Єврокод-2 Проектування залізобетонних конструкцій. Частина 1-1. Загальні правила і правила для споруд. - Брюссель, CEN, 2004. - 225 с.
4. Єврокод 2. Проектування залізобетонних конструкцій. Частина 1-1. Загальні правила і правила для споруд (EN 1992-1-1:2004, IDT): ДСТУ – Н Б EN 1992-1-1:2010. - [Чинний з 2013-07-01]. - Київ: ДП "Укрархбудінформ", 2012. - 312 с. - (Нац. стандарт України).
5. Бачинский В.Я. О потере устойчивости деформирования изгибаемого бруса // Республиканский межведомств. науч.-техн. сб. «Строит. Конструкции». - К.: Будівельник, 1982. - Вып. 35. - С. 51-55.

6. Бамбура А.М. Про втрату стійкості позациентрово стиснутих елементів з пружно-пластичного матеріалу // Механіка і фізика руйнування буд. матер. та конструкцій: зб. наук. праць. - Львів: Каменяр, 2002. - Вип. 5. - С. 213-218.
7. Биби Э.В. Руководство для проектировщиков к Еврокоду 2: Проектирование железобетонных конструкций. Пер. с английского / Биби Э.В., Нараянан Р.С. // ФГБОУ ВПО «МГСУ: Еврокоды». - М., 2012. - 292 с.

### REFERENCES

1. Concrete and reinforced concrete structures. General provisions. (2011). DBN V.2.6-98:2009 from 1<sup>st</sup> June 2011. K.: DP "Ukrarkhbuildinform". 97 p. (State Construction Norms of Ukraine) [in Ukrainian].
2. Structures of buildings and constructions. Concrete and reinforced concrete structures of heavy-weight concrete. Design rules. (2011). DSTU B V.2.6-156:2010 from 1<sup>st</sup> June 2011. K.: DP "Ukrarkhbuildinform" (Nat. standard of Ukraine) [in Ukrainian].
3. EN 1992-1-1 Eurocode 2. Design of concrete structures. Part 1-1 / General rules and rules for buildings (2004). Brussels: CEN, 2004. 225 p. [in English].
4. Design of concrete structures. Part 1-1 / General rules and rules for buildings (EN 1992-1-1:2004, IDT). (2013). DSTU-N B EN 1992-1-1.2010 from 1<sup>st</sup> July 2013. K.: DP "Ukrarkhbuildinform" (Nat. standard of Ukraine) [in Ukrainian and English].
5. Bachynskiy V.Ya. Concerning strain buckling of a bended rod // Coll. of scientific and technical papers "Building Structures". - K.: Budivelnik, 1982. Iss. 35. P. 51-55 [in Russian].
6. Bambura A.N. Buckling of the eccentric-compressed elements from an elasto-plastic material // Fracture mechanics and physics of construction materials and structures. Coll. of scientific works. Lviv: "Kamenjar", 2002. Iss. 5. P. 213-218 [in Ukrainian].
7. Bibi E.V., Narayanan R.S. Guidance of Eurocode-2 for designers: Design of reinforced concrete structures (Translation from English) // FGBOU VPO "MGSU: Eurocodes". - M., 2012. 292 p. [in Russian].

Article has been received in Editorial Board on July 18, 2018 y.