

II. ПРОБЛЕМИ МЕТОДИКИ НАВЧАННЯ ФІЗИКИ

THERMAL WAVE MICROSCOPY – A UNIQUE TOOL FOR NON-DESTROYING LEVEL-BY-LEVEL DIAGNOSTICS OF SEMICONDUCTOR STRUCTURES

Oleh VOLCHANSKYI

Пропонується спрощена теорія генерації фототермоакустичного сигналу, а також аналіз його залежності від оптичних, теплових і геометричних властивостей зразка. Обговорюються експериментальне обладнання та результати ФТА мікроскопії напівпровідникових структур. Аналізується унікальна можливість термохвильової мікроскопії проводити неруйнівну пошарову діагностику пристроїв напівпровідникової мікроелектроніки.

The paper presents a simplified theory of photothermoacoustic (PTA) signal generation and its dependence on the sample's optical, thermal and mechanical properties, geometric structure, etc. Both an experimental technique for the investigation and results of PTA microscopy of semiconductor structures in a university laboratory are discussed. The unique ability of thermal wave microscopy for non-destroying level-by-level diagnostic of semiconductor microelectronic devices is analysed.

Introduction

Studying waving process is an important part of a university Physics course. It includes carrying out laboratory works while studying “Mechanics”, “Electricity and Magnetism”, “Optics”, “Atomic and Nuclear Physics” [1].

Despite the variety of the researched characteristics of oscillations and phenomena, following their propagation (interference, diffraction, polarization, attenuation, dispersion, laws of photoeffect, discreteness of atoms and molecules spectra, etc.), only two types of waves are traditionally discussed at Physics lab works: mechanical and electromagnetic [2].

Meanwhile, other wave types, including such interesting type as heat waves, remain beyond laboratory sessions [3].

Currently thermal waves has been attracting scientists' attention as the unique tool for non-destroying diagnostic of microstructure of materials, in particular semiconductor microelectronic devices [4]. Traditional methods of research, such as optical, x-ray and electronical microscopy, have some restrictions. For example, optical and electronical microscopes are hardly suitable for research of the internal structure of high-absorbing materials; the use of x-ray microscope is connected with difficult decoding of the received images. Besides, one common fault is inherent in all listed types of microscopes – the impossibility of study of thermal properties of the samples.

Photothermoacoustic (PTA) effect is directly related to the sample's optical, thermal and mechanical properties, geometric structure, etc. Therefore, surface and subsurface features of a sample can be investigated by PTA signal detecting. Moreover, PTA (thermal wave) microscopy has a unique ability for non-destroying level-by-level diagnostic of the sample's structure.

Besides, PTA effect is well applicable in the spectral investigations of high-transparent, nontransparent and high-scattering materials, in particular in depth profiling of both transparent and nontransparent samples optical characteristics [5-6].

Simplified theory of PTA signal generation

Photothermoacoustic effect occurs when an investigated sample is irradiated by amplitude-modulated light. The absorbed part of light energy causes periodical heating and thermal expansion of the material. As a result, acoustic waves are generated both inside the sample, and in the environment.

Three types of waves can exist in a researched sample – optical, thermal and mechanical, and, as a result, PA signal contains information on the correspondent properties of the object. In semiconductors the generation of a PA signal is accompanied by the occurrence of electronical excitations, which have certain time of living and pass certain distance before recombination.

Hence, PA signal gets information on electrical parameters: average time of life, diffusion length, spatial distribution of impurities etc.

In order to qualitatively understand the mechanism of PA signal generation, let us consider a simplified one-dimensional model (Fig.1.). The solid isotropic infinite elastic layer by thickness d is homogeneously irradiated in a plane $x=0$ by modulated light.

The equation of the intensity modulation is

$$I = I_0(1 + \cos(\omega t))/2 \quad (1)$$

where I_0 is the incident laser intensity, ω – is the modulation angular frequency. For simplification of accounts we shall solve a model in complex recording.

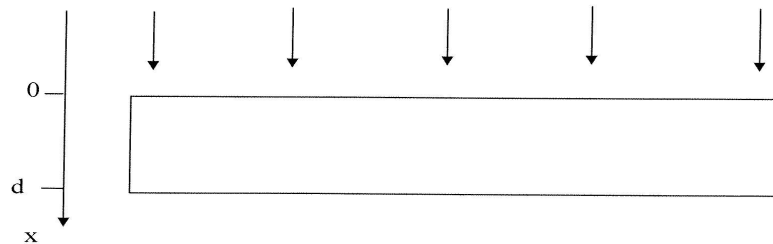

Fig.1.

Assuming that all absorbed light energy is transformed into the thermal one, we can describe the thermal field in the sample by the thermal conductivity equation:

$$c\rho \frac{\partial T}{\partial t} - \chi \frac{\partial^2 T}{\partial x^2} = \alpha \frac{I_0}{2} e^{-\alpha x} e^{i\omega t} \quad (2)$$

where c, ρ, χ, α are the specific heat, the density, the thermal conductivity and the optical absorption coefficient of the sample correspondingly, T – the harmonic component of the temperature on the depth x

Neglecting transfer of heat to the environment and considering thermal thick sample ($l \ll d$), we shall write down a boundary conditions as:

$$\left(\chi \frac{\partial T}{\partial x} \right)_{x=0} = 0, \quad (3a)$$

$$T(d, t) = 0 \quad (3b)$$

whence the result $T(x,t)$ can be written as:

$$T(x, t) = \frac{\alpha I_0}{2\chi(\eta^2 - \alpha^2)} \left(e^{-\alpha x} e^{i\omega t} - \frac{\alpha}{\eta} e^{-x/l} e^{i(\omega t - x/l)} \right) \quad (4)$$

The first component in (8) describes the temperature fluctuations caused by the modulated light absorption in this region, and another one – the heating that has come from other areas of the sample. It is the second component, which represents thermal wave. Thermal diffusion length $l = \sqrt{2\chi / \omega c\rho}$ corresponds to the distance, on which thermal wave is attenuated e times. Its wavelength is $\lambda_T = 2\pi l = 2\pi \sqrt{2\chi / \omega c\rho}$. It is seen that the thermal wave is attenuated for the distance λ_T in $e^{2\pi} = 534$ times

We find that the thermal waves have basic differences from acoustic and electromagnetic ones, because in the wave equation strong attenuation is incorporated.

Strong attenuation makes practically impossible direct registration of thermal waves (for example, by pyroelectric transducer), that, on the first sight, makes it difficult to study their properties in a laboratory. At the same time it is rather easy to detect acoustic waves, which arise inside the sample due to thermal expansion in the region of a thermal wave passage. It is necessary to note that as in a sound range acoustic wave on some orders longer than the thermal one, it in this case serves only as a passive carrier of the information obtained by the thermal wave.

Let us calculate the acoustic response of a sample (mechanical fluctuations of its non-irradiated surface) neglecting generation of heat at its deformation. Let us write down the thermal elasticity equation:

$$\frac{\partial^2 U}{\partial X^2} - \frac{1}{V^2} \frac{\partial^2 U}{\partial t^2} = \xi a \frac{\partial T}{\partial X}, \tag{5}$$

where U is the elastic displacement, V is the acoustic waves speed, a_T is the thermal expansion coefficient,

$$\xi = \frac{\alpha + \frac{2}{3}\mu}{\lambda + 2\mu}, \lambda \text{ and } \mu \text{ are Lamé constants.}$$

If the surfaces of the sample are free, we can obtain the result elastic displacement of the bottom side of the sample:

$$U_{x=d} = \frac{\alpha I_0 \xi a}{2\chi(\eta^2 - \alpha^2)} \frac{k}{\sin(kd)} \left[\frac{1}{\alpha^2 + k^2} - \frac{\alpha}{\eta(\eta^2 + k^2)} \right], \tag{6}$$

where k is the acoustic wave vector ($k = \omega/V$).

It is seen that the PA signal depends on the sample's optical (α), thermal and mechanical (η, ξ, k) properties and geometric structure (d). Therefore the spatial distribution of the optical, thermal and mechanical features can be investigated by detecting PA signal. According to the features contribution three modes of PA microscopy are separated: optical, thermal-wave and acoustic.

We can see that thermal-wave microscopy provides a unique capability for non-destructing detection of nontransparent solid subsurface structure. The visualization is caused by the thermal wave dispersion on the regions with variations of the specific heat, the density, and the thermal conductivity (such as microcracks, delaminations, voids, inclusions, lack of bonding etc.).

Due to the thermal wave strong attenuation, the harmonic component of the temperature creates "thermal probe" with a diameter about the thermal diffusion length ($l = (2\chi/\omega cp)^{1/2}$). It seen that we can change the depth of visualization by the frequency changing.

For example in Table 1 the thermal diffusion length for some materials are shown.

Table 1

The thermal diffusion length for some materials

Material	Density, g/sm ³	Specific heat, kal/g·K	Thermal conductivity, kal/s·ms·K	Thermal diffusion length at different frequencies, μm ($\nu = \omega/2\pi$)				
				$\nu = 10$ Hz	$\nu = 10^2$ Hz	$\nu = 10^3$ Hz	$\nu = 10^4$ Hz	$\nu = 10^5$ Hz
Al	2,7	0,216	0,48	1870	590	187	59	18,7
Si	2,33	0,168	0,45	1900	610	190	61	19,0
Ge	5,32	0,167	0,167	3670	1160	367	116	36,7

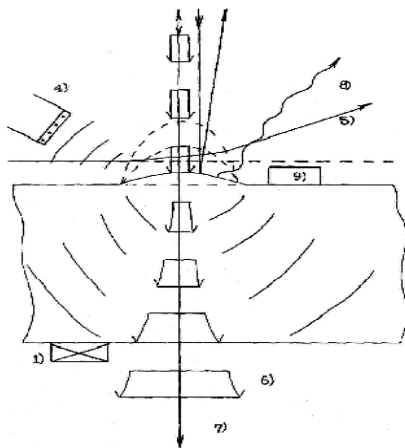

Fig.2. Methods of PA signal detection.

II. Methods of PA signal detection

Methods of PA signal detection can be separated into two groups. The first group is connected with detection of sample's surface mechanical fluctuations arising due PA effect (photomechanical methods). The second group includes investigation of phenomena accompanying the thermal wave (photothermal methods), which are not connected to sample's mechanical fluctuations. The general methods of PA signal detection are collected in Fig.2.

Among photomechanical (PM) methods we can specify:

- piezodetector method – detection of sample's surface mechanical fluctuations by piezoelectric detector;
- photodisplacement method – detection of

- periodic change of the reflection angle of probing optical beam due to sample's surface mechanical fluctuations;
- photointerferention method – detection of periodic change of the way of a reflected probing optical beam by interferometer.

The group of the photothermal methods is more numerous:

- gas-microphone method – detection of the acoustic waves generated due to the transfer of heat to environmental gas by a microphone;
- photodeflection method – detection of the periodical deflection of probing optical beam passing through the region heated by the surface of the sample;
- thermo-lens method – detection of probing optical beam extension in the field of modulated heating;
- refraction-interferention method – detection of the periodical change of probing optical beam phase shift in the field of modulated heating;
- photothermal radiometry – detection of the modulated optical radiation of the sample's surface caused by modulated heating (IR radiation);
- contact methods – direct detection of the sample's surface temperature (pyroelectric transducer, bolometer, etc.);
- photoreflexion method – detection of the periodical change of the sample's optical reflection coefficient by probing light beam.

Most of PA investigations are based on piezodetector and gas-microphone methods due to their high sensitivity and simplicity.

1. Simplified installation for PTA investigation

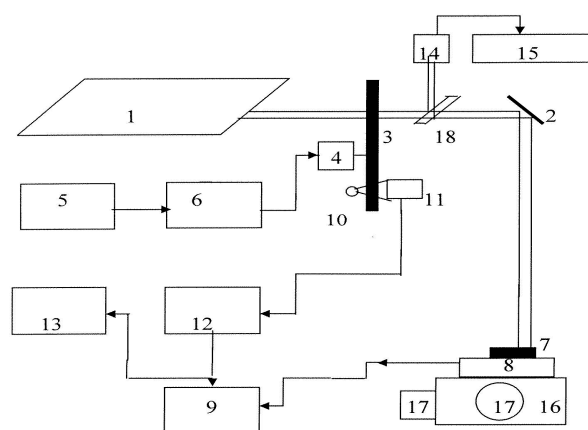

- 1 – pumping optical source (He-Ne laser or power lamp with monochromator);
- 2 – mirror;
- 3 – disk with periodically situated holes (chopper);
- 4 – the chopper's motor;
- 5 – low-frequency generator;
- 6, 12 – amplifiers;
- 7 – sample;
- 8 – PA signal detector 8 (piezodetector or gas-microphone cell);
- 9 – main amplifier with a synchronous detector (lock-in amplifier);
- 10 – lamp;
- 11, 14 – photodiodes;
- 15 – voltmeter;
- 16 – two-coordinate platform;
- 17 – micrometric screws;
- 18 – glass plate.

Fig.3. Block diagram of the simplified mounting for PA investigations

Block diagram of the simplified mounting for PTA investigations is shown in Fig.3. The radiation of the pumping optical source 1 (He-Ne laser or power lamp with monochromator) is modulated on intensity by the modulator 3-6. The modulator consists of mechanical chopper 3-4 and low-frequency generator 5 with amplifier 6.

Generator's signal supplies motor 4, which rotates disk 3. That disk has periodically situated holes and interrupts the laser beam. The modulator provides frequency range from 100 to 2000 Hz.

The laser beam by a mirror 2 is directed on a surface of the sample 7, which is in contact with the detector 8. The main amplifier 9 registers the result PTA signal. As the level of the result signal is low and comparable with the level of the environmental noise (μV), the main amplifier has a synchronous detector (lock-in amplifier). In this case the amplifier separates only signals identical under the form with the reference signal. Lamp 10 and photodiode 11 create the reference signal, which through the additional amplifier 12 goes to the main amplifier. The part of the reference signal goes to the frequency controller 13.

The PTA signal detector 8 is situated on

the two-coordinate platform 16. With the help of the micrometric screws 17 we can move the sample in relation to the falling beam at two perpendicular directions. The glass plate 18, the photodiode 14 and the voltmeter 15 help us to carry out the laser beam intensity control.

IV. PTA microscope

The above-described installation with mechanical chopper allowed us to carry out only spectral PA investigations or low-frequency thermal-wave diagnostic (less than 3 kHz). Mechanical choppers have the advantage of simplicity and 100% modulation depth. However, the resolution of PAM is dependent on the thermal diffusion length $l = (2\chi/\omega\text{cp})^{1/2}$ i.e. modulation frequency. Thus, mechanical chopper cannot be used with some thermal-wave imaging systems for which high resolution is required.

To increase PAM resolution we used installation with acoustic-and-optic modulator (AOM). The important advantage of AOM is that its modulation frequency is easy to change in a wide range and the desirable modulation wave form can be selected (sine wave or square wave). The modulation depth approaches 90%, which is very reasonable for PAM. The computer operates the situation of the two-coordinate scanning platform by the stepping motors. The lock-in amplifier selects the result PA signal and transfers it to the computer.

V. Testing experiment

A model sample was aluminum plate (5 μm thickness), in which at different depths were created cavities. In the first case the modulation frequency was 30 Hz (low frequency), and hence the thermal diffusion length (0,9 mm) was about cavities depth. As a result the thermal wave reached the cavities. Experiment showed that in that case the PA signal from the cavities region was stronger (Fig.4,a).

In the second case the modulation frequency was 2700 Hz (high frequency), and hence the thermal diffusion length (0,3 mm) was three times shorter than cavities depth. As a result the thermal wave practically did not reach the cavities. Experiment showed small increase of the PA signal from only the first cavity region.

We can see that thermal-wave microscopy provides a unique capability for non-destructing level-by-level detection of nontransparent solid subsurface structures. The visualization is caused by the thermal wave dispersion on the

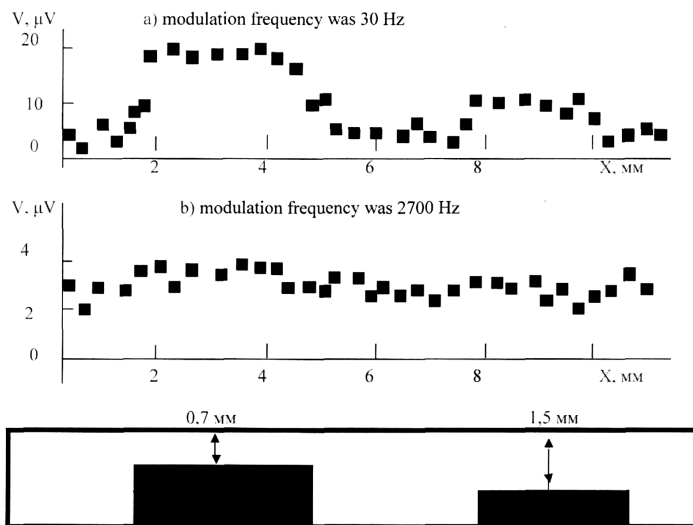

Fig.4. PTA topograms of aluminum plates

regions with variations of the density, and the thermal conductivity.

Acoustic waves are about 100 times longer than thermal waves at these frequencies. That is why acoustic waves serve only as a passive carrier of the information obtained due to thermal waves dispersion on the defects.

VI. Thermal wave depth profiling of epitaxial layers of semiconductor structures

In this part experimental results of PA microscopy of semiconductor structures are presented. In silicon wafers (n-type conductivity, 300 μm thickness) some deepening ("pockets") were performed. The "pockets" were filled by silicon of p-type conductivity by epitaxial growing. After the growing, polishing of the wafers down to occurrence p- and n-regions was performed, so as visually the pockets were not observed. Topology of the "pockets" situation is shown no Fig. 5.

The above-description shows that the resolution of PAM is dependent on the thermal diffusion length $l = (2\gamma/\omega c p)^{1/2}$ and requires focusing of the laser spot on the sample's surface. At scanning of the sample in relation to the falling beam the PA signal has to change. The signal grows there where the motion of heat is complicated ((breaks of the thermal conductivity).

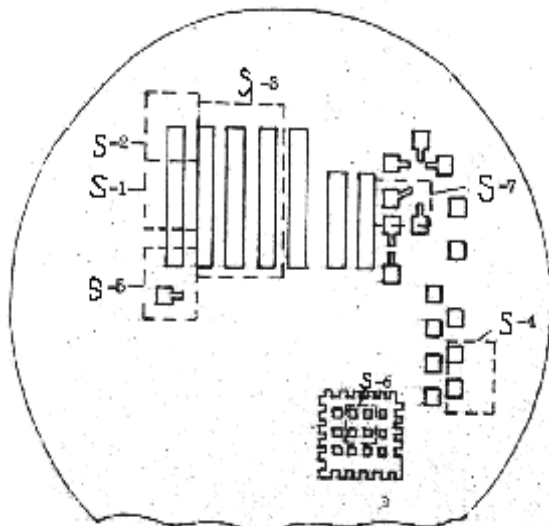

Fig. 5. Topology of the "pockets situation"

Two modes of PAM were carried out. In the first case the modulation frequency was 1700 Hz (low frequency), and hence the thermal diffusion length three times longer than pocket's depth. As a result the thermal wave reached the pocket's bottom.

In the second case the modulation frequency was about 100 kHz (high frequency), and hence the thermal wave did not reach the pocket's bottom, and imaging was possible only if difference between thermal properties of the wafer and layer exists.

The experiment showed that in the cases PA signal from the pockets was stronger. At low frequency it was stronger in 2-5 times, but at high frequency only by 10-20 %.

For example two lines of PA image at laser beam crossing of three epitaxial pockets at $f=1700$ Hz are shown in Fig.6.1 (S3 sample). The distance between researched areas is about 2 mm. It is visible, that in the field of the pockets increase of PA signal takes place. Comparing figures 6.1.a and 6.1.b we see that PA signals from different pockets have different levels. The additional check showed that this fact was not connected with experimental errors.

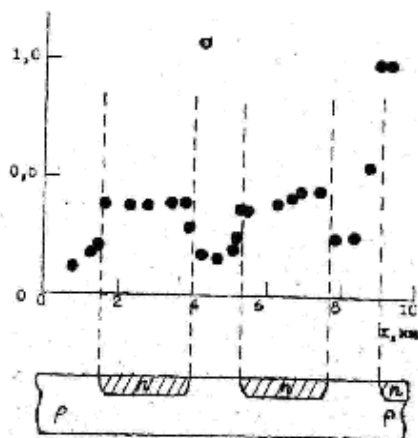

Fig. 6.1a Line of PA image (S3 sample) at $f=1700$ Hz

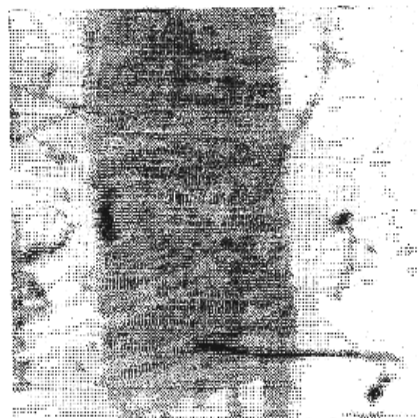

Fig. 6.1,b PA image (S3 sample) at $f=100$ kHz

At high modulation frequency (100 kHz), when the thermal wave did not reach the pocket's bottom, the difference of PA signals from p- and n- regions decreases. But decreasing of the thermal probe diameter allows to image smaller details of the sample's thermal structure. For example PA image of S2 sample at 100 kHz frequency is shown in Fig.5.2. More dark areas correspond to the higher PA signal level. We can see dark areas both in the pocket, and in the substrate. This fact shows strong non-uniformity of distribution of their thermal properties in the subsurface region. It is necessary to note good reproducibility of these results.

It is interesting to note that the thermal structure of S-6 sample is invisible at low frequency but becomes seen at higher frequencies. In this sample the distance between n- pockets is about 100 μm . The thermal probe diameter at 100 kHz frequency is about 25 μm and we can see well PA image despite the fact that only 30% of a thermal wave energy reaches the interface pocket-substrate (Fig. 7,a).

The thermal probe diameter at 1700 Hz frequency is about 150 μm and consequently does not allow to image such fine details. Line of the PA image (Fig. 7,b) shows practically identical signal's level to all areas of the sample. Thus, imaging is carried out in a thermal wave mode.

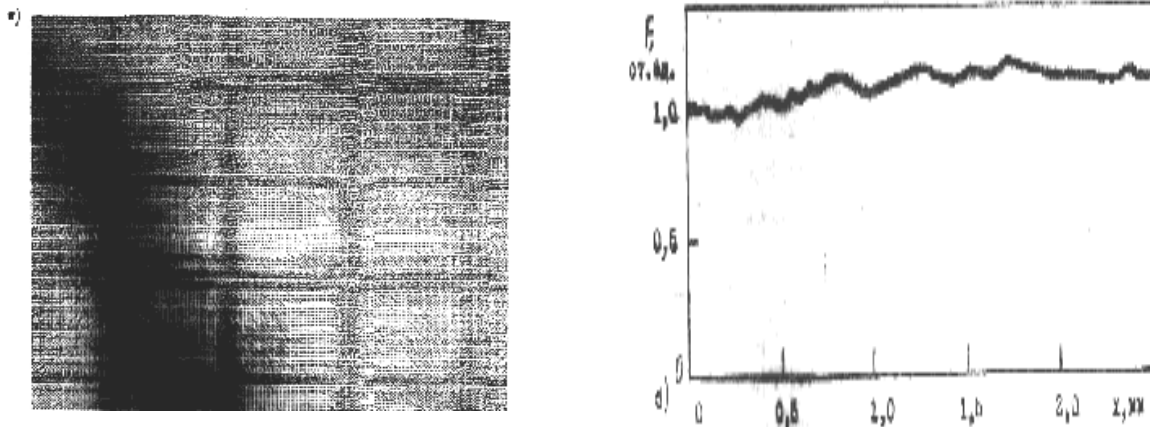

Fig. 7,a. PTA image (S6 sample) at $f=100$ kHz Fig. 7,b. Line of PTA image at $f=1700$ Hz

Conclusions

Photoacoustic microscopy, due to its unique capabilities for non-destructive surface and subsurface structure detection and depth profiling of opaque materials is a very efficient tool for semiconductor microelectronic devices examination. By using PAM, we can “see” inside objects and locate defects and changes in material properties, such as microcracks, delaminations, voids, inclusions, lack of bonding etc., which are not evident on the outside surface.

In comparison with other similar techniques, the advantages of PAM are:

1) In most opaque materials, caslength is about ten-hundred times less than the acoustic wavelength at the same frequency. Thus, in order to obtain the same resolution of subsurface structure imaging, the operating frequency may be 10-100 times lower than that of acoustic microscopy and resulting electric signals from the transducer can be easily processed by using lock-in demodulation.

2) PAM imagine can be carried out in air, under natural circumstances, and with ease of operation. However, high spatial resolution acoustic imagine must be performed in a vacuum chamber.

Familiarizing students with thermal waves would permit the former to more profoundly study the peculiarities of wave processes, their universal character and to consolidate the knowledge of “Thermodynamics”.

REFERENCES

1. Програми для фізико-математичних факультетів педінститутів. Зб.№ 2. За заг ред. М.І.Шкіля та Г.П.Грищенка. – К.: РОВО “Укрвузполіграф”, 1992 – 144 с.
2. Лабораторный практикум по общей физике (под ред. Е.М.Гершензона, Н.Н.Малова. – М.: Просвещение, 1985. – 351 с.
3. G.Busse. Imaging with Optically Generated thermal Waves / G. Busse // IEEE Transactions on Sonics and Ultrasonics. – 1985. – Vol.SU-32, №2. – P.355–364.
4. Siu E.K. A. Thermal-wave microscopy of semiconductor devices / E.K.M. Siu, M. A. Rosencwaig // IEEE Ultrasonic Symp. Proa. – 1981. – Vol.2, p. 828–831.
5. Жаров В.П. Лазерная оптико-акустическая спектроскопия / В. П. Жаров, В. С. Летохов. – М.: Наука, 1975. – 320 с
6. Сверхчувствительная лазерная спектроскопия [под ред. Д. Клайджера]. – М.: Мир, 1986. – 519 с.

ВІДОМОСТІ ПРО АВТОРА

Волчанський Олег Володимирович – кандидат фізико-математичних наук, доцент кафедри фізики та методики її викладання Кіровоградського державного педагогічного університету імені Володимира Винниченка.
Коло наукових інтересів: фототермічні та фотоакустичні явища в напівпровідниках, методика фізики.

**КУЛЬТУРОЛОГІЧНИЙ ПІДХІД ДО ФОРМУВАННЯ ЗМІСТУ
НАВЧАННЯ ФІЗИКИ У КОЛЕДЖАХ ЕКОНОМІЧНОГО
ПРОФІЛЮ**

В'ячеслав БІЛЕЦЬКИЙ

У статті розглянуто проблема культурологічного підходу до формування змісту навчання фізики в коледжах економічного профілю та умови реалізації виховних функцій.

In the article the author disclosed the problem of culturological approach to studies physics economic

Людство вступило в III-є тисячоліття своєї історії. Стрімко набирає обертів XXI століття. Відбуваються складні, неоднозначні зміни як у економічному середовищі проживання людини, так і в суспільстві загалом. Нова реальність, безумовно, знаходить своє «віддзеркалення» в освіті, яка виступає як основний чинник забезпечення культурного зрушення, оновлення, як соціально-економічного устрою так і всіх аспектів життєдіяльності суспільства.

Аналіз філософсько-культурологічної, психолого-педагогічної літератури дає підстави констатувати постійне зростання уваги до культурологічних проблем освіти і виховання як результату системного і полісистемного розгляду зв'язків освіти і культури. Така взаємодія визнається у науковому світі як норма, яка виводиться із самого визначення культури (І. Зязюн, М. Каган, Н. Крилова, В. Луговий, Н. Щубелка та ін.). Це зумовлює чітку тенденцію до пошуку нових шляхів та підходів до організації професійної підготовки студентів у ВНЗ, адекватних сучасній культурі й науці. Культурологічний підхід, який розширює дослідницькі і прикладні межі, забезпечує панорамний багатомірний погляд освітнього процесу і обґрунтовується в роботах А. Арнольдова, Є. Бондаревської, О. Рудницької, Г.Тарасенка, Н. Щуркової, М. Вебера, П. Сорокіна, Т. Адорно, Г. Маркузе, В. Біблера, А. Лосева У. Берча, І. Вутрі, У. Гільфорда, А. Гропле та інших.

Культурологічний підхід являє собою вчення про цінності. Людина розвивається шляхом освоєння нею культури як системи цінностей і одночасно стає творцем нових елементів культури, тобто відбувається становлення індивіда як творчої особистості. Тому культурологічний підхід ґрунтується на положенням А. Дістерверга про культуровідповідність виховання; І. Гербарта про культурну індивідуальність особистості, тобто культура розглядається як природне середовище виховання і розвитку особистості; культура виступає як мета і засіб, а також як результат навчально-виховного процесу; культуротворча функція навчання і виховання знаходить вияв у створенні культурних цінностей. Головною з яких є особистість.

В.М.Розін [8, с. 46] в своїх роботах відзначає, що освічена людина – це не тільки фахівець і не тільки особа, а саме людина культурна і підготовлена до життя, до змін способу життя, до зміни своїх уявлень, світоглядів; освічена людина є культурною і в тому сенсі, що приймає і розуміє інші культурні позиції

Культурологічний підхід представляє для нас особливий інтерес, оскільки допомагає виявити соціокультурні проблеми, вирішити їх на базі ідей і принципів, відповідних сучасній культурі, і ставити нові питання, що дозволяють переосмислювати сучасну педагогіку: 1) які зміни необхідні для поглиблення зв'язків з культурою?; 2) що саме треба міняти в теорії утворення, щоб вона відповідала новим культурним ідеям?; 3) як наповнити зміст і форми освіти культурними компонентами.

Зараз гостро стоїть питання про формування культури фахівця економічного профілю, в якому гармонійно поєднувався б високий професіоналізм, інтелігентність, а також творчий початок. У законі України «Про освіту» в основних вимогах до змісту освіти підкреслюється,